



# Block 1 Report

## Sydney Metro C&SW - Traffic and Interchange Monitoring

11-Aug-2023  
Sydney Metro City and Southwest - Traffic and Interchange Monitoring  
Doc No. 60705686-ACM-00-RPT-TR-001-R01

## Block 1 Report

Sydney Metro C&SW - Traffic and Interchange Monitoring

Client: Sydney Metro

ABN: 12 354 063 515

Prepared by

**AECOM Australia Pty Ltd**

Gadigal Country, Level 21, 420 George Street, Sydney NSW 2000, PO Box Q410, QVB Post Office NSW 1230, Australia  
T +61 2 8008 1700 www.aecom.com

ABN 20 093 846 925

11-Aug-2023

Job No.: 60705686

AECOM in Australia and New Zealand is certified to ISO9001, ISO14001 and ISO45001.

© AECOM Australia Pty Ltd (AECOM). All rights reserved.

AECOM has prepared this document for the sole use of the Client and for a specific purpose, each as expressly stated in the document. No other party should rely on this document without the prior written consent of AECOM. AECOM undertakes no duty, nor accepts any responsibility, to any third party who may rely upon or use this document. This document has been prepared based on the Client's description of its requirements and AECOM's experience, having regard to assumptions that AECOM can reasonably be expected to make in accordance with sound professional principles. AECOM may also have relied upon information provided by the Client and other third parties to prepare this document, some of which may not have been verified. Subject to the above conditions, this document may be transmitted, reproduced or disseminated only in its entirety.



## Quality Information

Document      Block 1 Report  
 Ref            60705686  
 Date           11-Aug-2023  
 Originator     Gabrielle Mcerlane, Mark Yeung, Sara Hu  
 Checker/s      Padmanaban Subramanian/Ronaldo Manahan  
 Verifier/s      Anoop Sridhar

### Revision History

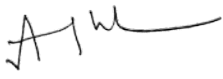
| Rev | Revision Date | Details   | Approved                                    |   |
|-----|---------------|---|---|---|
|     |               |   | Name/Position                               | Signature   |
| A   | 01-Aug-2023   | For Issue   | Anoop Sridhar<br>Principal Traffic Engineer |   |
| B   | 11-Aug-2023   | Final report - updated to incorporate Sydney Metro comments | Anoop Sridhar<br>Principal Traffic Engineer |  |
|     |               |   |   |   |
|     |               |   |   |   |

## Table of Contents

|   |     |
|---|-----|
| Terms and abbreviations                             | 5   |
| 1.0 Introduction                                    | 6   |
| 1.1 Project overview                                | 6   |
| 1.2 Purpose of this report                          | 7   |
| 1.3 Scope of this study                             | 7   |
| 1.4 Structure of this report                        | 8   |
| 2.0 Context and background                          | 9   |
| 2.1 Context   | 9   |
| 2.2 Background                                      | 10  |
| 3.0 Study area                                      | 11  |
| 3.1 Overview  | 11  |
| 3.2 Traffic monitoring                              | 12  |
| 3.3 Transport interchange monitoring                | 24  |
| 4.0 Assessment methodology                          | 27  |
| 4.1 Traffic monitoring                              | 27  |
| 4.2 Transport interchange monitoring                | 29  |
| 5.0 Traffic monitoring and intersection performance | 31  |
| 5.1 Chatswood Dive Site                             | 31  |
| 5.2 Crows Nest Station                              | 35  |
| 5.3 Victoria Cross Station                          | 54  |
| 5.4 Barangaroo Station                              | 62  |
| 5.5 Martin Place Station                            | 85  |
| 5.6 Pitt Street Station                             | 95  |
| 5.7 Central Station                                 | 102 |
| 5.8 Waterloo Station                                | 109 |
| 5.9 Sydenham Station                                | 119 |
| 6.0 Transport interchange monitoring                | 128 |
| 6.1 Chatswood Station                               | 128 |
| 6.2 Sydenham Station                                | 134 |
| 7.0 Summary   | 142 |
| Appendix A Stakeholder Meeting Minutes              | A-1 |
| Appendix B SIDRA Intersection Modelling Assumptions | B-1 |
| Appendix C Network Flow Diagrams                    | C-4 |
| Appendix D Traffic Monitoring – Station Overview    | D-1 |
| Appendix E Movement Summary Outputs                 | E-1 |



## Terms and abbreviations

| Term                                | Definition  |
|-------------------------------------|---|
| AECOM                               | AECOM Australia Pty Ltd   |
| Block 1                             | The first study block of the traffic and interchange monitoring program   |
| BOAM                                | Bus Opal Assignment Model   |
| CBD                                 | Central Business District   |
| CoA                                 | Conditions of Approval  |
| Condition D12                       | Refers to Item D12 of the Sydney Metro City & Southwest Chatswood to Sydenham conditions of approval, which specifies requirements for traffic operational monitoring of the Sydney Metro City & Southwest Chatswood to Sydenham. |
| CSELR                               | CBD and South-East Light Rail   |
| CSSI                                | Critical State Significant Infrastructure   |
| IAP                                 | Interchange Access Plan   |
| LOS                                 | Level of Service  |
| post-opening                        | denotes post-opening scenarios of the Sydney Metro City & Southwest line operating between Chatswood to Sydenham  |
| pre-opening                         | denotes pre-opening scenarios of the Sydney Metro City & Southwest line operating between Chatswood to Sydenham   |
| PTIPS                               | Public Transport Information and Priority Systems   |
| SCATS                               | Sydney Coordinated Adaptive Traffic System  |
| SIDRA Intersection                  | SIDRA Intersection modelling software, the modelling software used to assess the traffic performance.   |
| SHB                                 | Sydney Harbour Bridge   |
| Sydney Metro                        | A New South Wales Government Agency constituted under the <i>Transport Administration Act 1988 (NSW)</i> .  |
| Sydney Metro City & Southwest       | The metro railway between Chatswood and Bankstown, including 15.5 kilometres of twin metro railway tunnels from Chatswood to Marrickville under Sydney Harbour.   |
| Sydney Metro Northwest              | The former Northwest Rail Link, i.e. operating metro railway between Tallawong Station at Rouse Hill and Chatswood.   |
| Sydney Metro West                   | The metro railway that will connect the Sydney CBD and Parramatta, linking communities along the way with a new underground railway.  |
| Sydney Metro Western Sydney Airport | The metro railway that will link St Marys to the Western Sydney International (Nancy Bird Walton) airport and the Aerotropolis.   |
| TfNSW                               | Transport for NSW (A New South Wales Government Agency constituted under the <i>Transport Administration Act 1988 (NSW)</i> ).  |
| the Project                         | Traffic and interchange monitoring assessments for the Sydney Metro City & Southwest Chatswood to Sydenham  |
| TCS                                 | Traffic Control Signal  |
| TSN                                 | Transit Stop Number   |

# 1.0 Introduction

This section provides an introduction of the traffic and interchange monitoring for the Sydney Metro City & Southwest (C&SW) between Chatswood Station and Sydenham Station (the Project), including the project overview, project objectives and overall scope of works covered under this Project.

## 1.1 Project overview

Sydney Metro is the largest public transport project in Australia, designed to address congestion, enhance connectivity, and meet the evolving needs of Sydney’s population and economy. It encompasses four major metro lines: Sydney Metro Northwest, Sydney Metro West, Sydney Metro Western Sydney Airport, and Sydney Metro City & Southwest.

AECOM Australia Pty Ltd (AECOM) has been appointed by Sydney Metro to conduct traffic and interchange monitoring assessments for the Sydney Metro City & Southwest between Chatswood Station and Sydenham Station (the Project).

The purpose of this assessment is to evaluate the impact of the Sydney Metro City & Southwest (Chatswood to Sydenham) operations on the nine stations and their surrounding intersections and interchange facilities. The study involves evaluating the performance of these intersections and interchange both before and after the introduction of the metro line. This assessment is crucial for fulfilling the requirements of the Critical State Significant Infrastructure (CSSI) application Conditions of Approval (CoA) overseen by the NSW Department of Planning and Environment.

Traffic and interchange monitoring will be conducted in six study blocks, spanning a period of 12-months before the commencement of the CSSI operations (pre-opening) and 12-months after the commencement (post-opening). This comprehensive monitoring approach will provide insights into the traffic and interchange dynamics during different stages of the Sydney Metro City & Southwest Line (Chatswood to Sydenham), allowing for a thorough and robust impact assessment.

Figure 1-1 presents a timeline overview of the study blocks, highlighting the specific periods under observation.

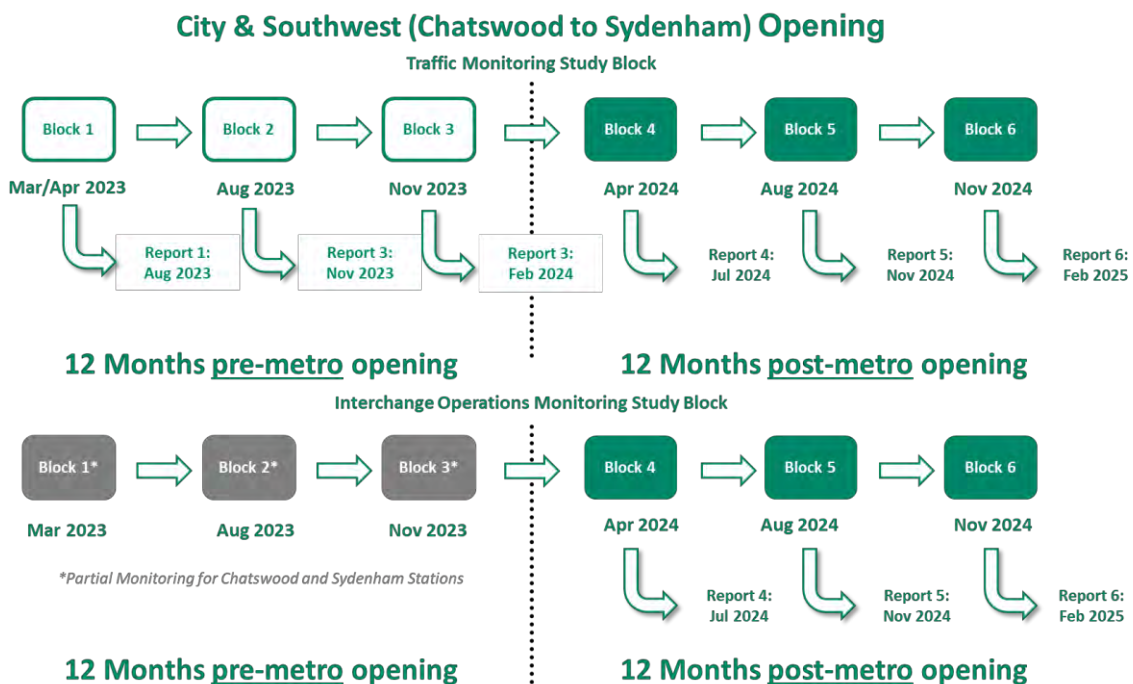

Sydney Metro City & Southwest: Chatswood to Sydenham opening is April 2024 (subject to change depending on CSW program)

Figure 1-1 Traffic and interchange monitoring program



## 1.2 Purpose of this report

The Sydney Metro City & Southwest Chatswood to Sydenham – Traffic and Interchange Operation Monitoring report (this report) is prepared to meet the requirements of Condition D12 of the CoA (outlined in **Section 2.2**).

This report provides traffic and interchange operation assessments of the nine stations along the Sydney Metro City & Southwest Line (Chatswood to Sydenham) during the monitoring timeframe between March 2023 to April 2023 (Block 1).

## 1.3 Scope of this study

The overall scope of works for the Block 1 study covers the following:

- **Traffic monitoring:** Intersection surveys were conducted in late-March 2023, early-April 2023 and early-May (re-surveys) 2023, including:
  - classified intersection count surveys conducted continuously for a one-week period, including light vehicles, heavy vehicles, buses, cyclist and pedestrian counts
  - vehicular queue length surveys (at the signal change to green for signalised intersections and aggregated every 2 minutes for priority intersections) conducted for the following nominated peak periods during the same one-week period:
    - weekday AM peak: 6am–10am
    - weekday PM peak: 3pm–7pm
    - weekend peak: 10am–2pm.
- **Transport interchange monitoring:** only Chatswood Station and Sydenham Station were considered for the interchange monitoring for the Block 1 study due to the existing operational train/metro stations. Interchange operation surveys were conducted at these two stations continuously for a one-week period same as intersection surveys in late-March 2023, early-April 2023 and early-May (re-surveys) 2023. Interchange operation surveys collected the following information for taxi, bus stop and kiss and ride facilities at each station:
  - vehicle counts
  - vehicle occupancy (boarding and alighting passengers only)
  - vehicle dwell time
  - vehicle queue length outside the bay on a lane-by-lane basis.
- **Site observations:** Site visits were undertaken in conjunction with the traffic and interchange operation monitoring for at least one weekday AM peak, one weekday PM peak, and one weekday peak period at each station.
- **Intersection assessment:** To assess the intersection operation performance during Block 1, a combination of isolated and network traffic modelling assessments was undertaken using SIDRA Intersection modelling software (SIDRA Intersection). The following data were obtained from Sydney Metro for developing the SIDRA Intersection models:
  - Sydney Coordinated Adaptive Traffic System (SCATS) traffic detector count data
  - SCATS traffic signal data and sub-systems information.
- **Stakeholder consultation:** Key findings of the Block 1 study were provided to Sydney Metro and the following key stakeholders in July 2023 for review and feedback:
  - Transport for NSW (TfNSW)
  - Willoughby City Council
  - North Sydney City Council

- City of Sydney
- Inner West Council.

Additionally, Block 1 study findings were presented to TfNSW, Willoughby City Council and Inner West Council. **Appendix A** provides the minutes from these stakeholder meetings.

#### **1.4 Structure of this report**

This report is structured as follows:

- Section 1.0 provides an introduction to the Project.
- Section 2.0 provides the context and background of the Project.
- Section 3.0 outlines the study area of the Project.
- Section 4.0 describes the methodology adopted for the traffic and interchange operation assessments.
- Section 5.0 details the traffic monitoring and intersection performance.
- Section 6.0 details the interchange monitoring performance.
- Section 7.0 provides a summary of the traffic and interchange monitoring.



## 2.0 Context and background

This section provides an overview of the strategic context of the Project within the overall Sydney Metro program and the background of the CSSI Conditions of Approval (CoA) for the Sydney Metro City & Southwest Line (Chatswood to Sydenham).

### 2.1 Context

Sydney Metro is Australia’s largest public transport project, aiming to alleviate congestion, improve connectivity, and support the growing population and economic needs of Sydney. The main objectives of Sydney Metro are to enhance the overall transport experience, establish a robust and sustainable transport system, increase public transport usage and enhance the resilience of the transport network.

By 2030, Sydney Metro is expected to create a network of four metro lines (Northwest, West, Western Sydney Airport, and City & Southwest), spanning 113 kilometres, and encompassing 46 stations.

#### 2.1.1 Sydney Metro Northwest

Sydney Metro Northwest marked the initial phase of the Sydney Metro project, commencing operations in May 2019. Spanning approximately 36 kilometres from Tallawong to Chatswood, this line consists of 13 stations.

#### 2.1.2 Sydney Metro City & Southwest

Sydney Metro City & Southwest further extends the constructed Sydney Metro Northwest from Chatswood to Bankstown via the Sydney Central Business District (CBD) with 30 kilometres of metro rail. Sydney Metro City & Southwest between Chatswood and Sydenham is due to open in 2024 with seven new metro stations and 11 upgraded stations, as shown in **Figure 2-1**. This will establish connectivity between metro stations in the city and southwest with those further west, including future metro stations on the Sydney Metro West and Sydney Metro Western Sydney Airport.

Sydney Metro City & Southwest project consists of two phases: Chatswood to Sydenham; and Sydenham to Bankstown. This study focuses on the assessments for the Chatswood to Sydenham phase of the Sydney Metro City & Southwest project.



Figure 2-1 Sydney Metro City & Southwest overview

### 2.1.3 Sydney Metro West

Sydney Metro West is an upcoming 24-kilometre metro line that will establish a vital connection between Greater Parramatta and the Sydney CBD, linking the communities along its route. This line will incorporate 10 new metro stations, located at key destinations including Westmead, Parramatta, Sydney Olympic Park, The Bays Precinct, and the Sydney CBD.

Construction for the Sydney Metro West project commenced in 2020 and is currently in progress.

### 2.1.4 Sydney Metro Western Sydney Airport

Sydney Metro Western Sydney Airport line is an upcoming 23-kilometre line and will link the new Western Sydney International (Nancy-Bird Walton) Airport with the Western Sydney Aerotropolis, and St Marys. The Sydney Metro Western Sydney Airport project includes the construction of six new metro stations and will provide connectivity to the existing Sydney Trains suburban T1 Western Line.

Construction for the Sydney Metro Western Sydney Airport project commenced in 2020 and is currently in progress.

## 2.2 Background

On 10 January 2017, the NSW Minister for Planning granted approval to the CSSI application for the Sydney Metro City & Southwest Chatswood to Sydenham. The infrastructure approval, which is regulated under Section 115ZB of the *Environmental Planning and Assessment Act 1979*, is subject to the Minister's conditions of approval for the CSSI.

The Conditions of Approval are administered by the NSW Department of Planning and Environment (previously the NSW Department of Planning, Industry and Environment) and delivered by the Proponent – Sydney Metro.

Part D of the Conditions of Approval outlines conditions for environmental management during operations of the project. Condition D12 specifies the requirement for traffic operational monitoring of the Project as per the following requirement:

*“Traffic on local roads around each station must be monitored 12 months before the CSSI commences operation and for a period of no less than 12 months after commencement of operation. If monitoring indicates unacceptable traffic intrusion on local roads/streets as a result of operation of the CSSI beyond those that could reasonably be predicted in the EIS and/or Interchange Access Plan(s) in Condition E92, appropriate traffic management measures to mitigate the monitored impacts must be implemented following consultation with the Sydney Coordination Office and Relevant Road Authorities.”*



## 3.0 Study area

This section provides an overview of the study area for both traffic and interchange monitoring, which was identified by Sydney Metro in consultation with key stakeholders (as listed in **Section 1.3**) during late 2022.

### 3.1 Overview

The Sydney Metro City & Southwest Line (Chatswood to Sydenham) includes a total of nine stations. For ease of referencing, each station has been assigned a three-character identifier based on the TfNSW Asset Reference Codes Register<sup>1</sup>. **Table 3-1** displays the list of these stations along with their corresponding identifiers.

**Table 3-1 Station three-character identifiers**

| Station                          | Station ID <sup>1</sup> |
|----------------------------------|-------------------------|
| Chatswood                        | CWD <sup>3</sup>        |
| Chatswood Dive Site <sup>2</sup> |                         |
| Crows Nest                       | CST                     |
| Victoria Cross                   | VIC                     |
| Barangaroo                       | BGU                     |
| Martin Place                     | MPL                     |
| Pitt Street                      | PIT                     |
| Central                          | CEN                     |
| Waterloo                         | WLO                     |
| Sydenham                         | SYD                     |

Notes:

- 1) [TfNSW Asset Codes Register TS 01499:2.00 Version 2](#) has been used as a reference.
- 2) *Chatswood Dive Site is not a station*
- 3) *Note CWD refers to Chatswood Dive Site in the context of the traffic assessment and Chatswood Station in the context of the interchange operation monitoring assessment.*

All stations in Block 1, except Sydenham Station, had either traffic monitoring or interchange operation monitoring, while Sydenham Station had both intersection and interchange monitoring.

**Table 3-2** outlines the type of assessment undertaken for each station in the Block 1 study.

**Table 3-2 Assessments undertaken for each station in Block 1**

| Station             | Traffic monitoring | Interchange monitoring | Remarks                                     |
|---------------------|--------------------|------------------------|---|
| Chatswood           | ✗                  | ✓                      | No changes to road network                  |
| Chatswood Dive Site | ✓                  | ✗                      | No new kerbside usage proposed              |
| Crows Nest          | ✓                  | ✗                      | Interchanges not operational during Block 1 |
| Victoria Cross      | ✓                  | ✗                      | Interchanges not operational during Block 1 |
| Barangaroo          | ✓                  | ✗                      | Interchanges not operational during Block 1 |
| Martin Place        | ✓                  | ✗                      | No new kerbside usage proposed              |

| Station     | Traffic monitoring | Interchange monitoring | Remarks                                     |
|-------------|--------------------|------------------------|---|
| Pitt Street | ✓                  | ✗                      | No new kerbside usage proposed              |
| Central     | ✓                  | ✗                      | No new kerbside usage proposed              |
| Waterloo    | ✓                  | ✗                      | Interchanges not operational during Block 1 |
| Sydenham    | ✓                  | ✓                      | Nil   |

### 3.2 Traffic monitoring

The study area for traffic monitoring comprises a total of 65 intersections spread across the nine stations. To facilitate ease of reference, each intersection is assigned two unique identifiers:

- Intersection ID: A five-character code formed by combining the three-character identifier of the corresponding station (as listed in **Table 3-1**) with the index of the intersection within the study area surrounding that station. For example, CEN03 represents the third intersection in the Central Station study area.
- S.ID: A two-character identifier used to index all intersections within the Project study area.

**Table 3-3** outlines each intersection's S.ID, Intersection ID, traffic control signal (TCS) ID designated by TfNSW, name, and control type. Of the 65 intersections within the study area, 60 intersections were assessable via SIDRA Intersection modelling during Block 1. The following pedestrian mid-block crossings were not operational during Block 1 and hence excluded from the analysis:

- BGU16 – New Pedestrian Mid-block Crossing at New Hickson Road (north of Metro Station)
- BGU17 – New Pedestrian Mid-block Crossing at New Hickson Road (south of Metro Station)
- CEN04 – New Pedestrian Mid-block Crossing at Randle Lane
- WLO06 – New Pedestrian Mid-block Crossing at Cope Street.

Additionally, the pedestrian bridge crossing along Mowbray Road (CWD02) was solely included in traffic surveys for data collection and was not modelled.

Figure 3-1 to Figure 3-9 depict the location of each intersection within each station's study area based on their Intersection ID.

**Table 3-3 Traffic assessment intersections**

| S.ID | Intersection ID | TCS ID | Intersection name                              | Intersection control type         |
|------|-----------------|--------|--|-----------------------------------|
| 01   | CWD01           | 3037   | Mowbray Road / Hampden Road                    | Signal                            |
| 02   | CWD02           | -      | Pedestrian Bridge Crossing along Mowbray Road  | Pedestrian only - Bridge Crossing |
| 03   | CST01           | 768    | Pacific Highway / Albany Street                | Signal                            |
| 04   | CST02           | 767    | Pacific Highway / Oxley Street                 | Signal                            |
| 05   | CST03           | 766    | Pacific Highway / Hume Street                  | Signal                            |
| 06   | CST04           | 765    | Pacific Highway / Falcon Street / Shirley Road | Signal                            |
| 07   | CST05           | -      | Clarke Street / Oxley Street                   | Priority - Give Way               |
| 08   | CST06           | -      | Clarke Street / Hume Street                    | Priority - Give Way               |
| 09   | CST07           | -      | Clarke Street / Willoughby Road                | Priority - Give Way               |

| S.ID | Intersection ID | TCS ID | Intersection name  | Intersection control type |
|------|-----------------|--------|--|---------------------------|
| 10   | CST08           | 516    | Albany Street / Willoughby Road  | Signal                    |
| 11   | CST09           | -      | Albany Street / Oxley Street   | Roundabout                |
| 12   | CST10           | -      | Albany Street / Clarke Lane  | Priority - Give Way       |
| 13   | CST11           | -      | Oxley Street / Clarke Lane   | Priority - Give Way       |
| 14   | CST12           | -      | Hume Street / Clarke Lane  | Priority - Stop           |
| 15   | CST13           | 763    | Pacific Highway / Alexander Street   | Signal                    |
| 16   | CST14           | 764    | Falcon Street / Alexander Street   | Signal                    |
| 17   | VIC01           | 1206   | Pacific Highway / Berry Street   | Signal                    |
| 18   | VIC02           | 874    | Miller Street / Berry Street   | Signal                    |
| 19   | VIC03           | 1156   | Miller Street / McLaren Street   | Signal                    |
| 20   | VIC04           | 630    | Pacific Highway / Miller Street  | Signal                    |
| 21   | BGU01           | -      | Hickson Road / Towns Place   | Priority - Give Way       |
| 22   | BGU02           | -      | Dalgety Road / Towns Place   | Roundabout                |
| 23   | BGU03           | -      | Kent Street / Argyle Street  | Priority - Give Way       |
| 24   | BGU04           | 4272   | Pedestrian Mid-block Crossing at Kent Street near Gas Lane                     | Pedestrian only - Signal  |
| 25   | BGU05           | 4272   | Kent Street / Sydney Harbour Bridge (SHB) On-ramp                              | Signal                    |
| 26   | BGU06           | 4625   | Hickson Road / Napoleon Street / Sussex Street                                 | Signal                    |
| 27   | BGU07           | 308    | Margaret Street / Kent Street / Napoleon Street                                | Signal                    |
| 28   | BGU08           | 319    | Margaret Street / Clarence Street  | Signal                    |
| 29   | BGU09           | 3042   | Margaret Street / York Street  | Signal                    |
| 30   | BGU10           | 3939   | Pedestrian Mid-block Crossing at Sussex Street under Exchange Place            | Pedestrian only - Signal  |
| 31   | BGU11           | 4109   | Pedestrian Mid-block Crossing at Kent Street near Margaret Street              | Pedestrian only - Signal  |
| 32   | BGU12           | 310    | Sussex Street / Erskine Street   | Signal                    |
| 33   | BGU13           | 307    | Kent Street / Erskine Street   | Signal                    |
| 34   | BGU14           | 284    | Sussex Street / King Street  | Signal                    |
| 35   | BGU15           | 283    | Kent Street / King Street  | Signal                    |
| 36   | BGU16           | -*     | New Pedestrian Mid-block Crossing at New Hickson Road (north of Metro Station) | Pedestrian only - Signal  |
| 37   | BGU17           | -*     | New Pedestrian Mid-block Crossing at New Hickson Road (south of Metro Station) | Pedestrian only - Signal  |
| 38   | BGU18           | 305    | Shelley Street / Erskine Street  | Signal                    |

| S.ID | Intersection ID | TCS ID | Intersection name                                   | Intersection control type |
|------|-----------------|--------|---|---------------------------|
| 39   | MPL01           | 244    | Hunter Street / Castlereagh Street / Bligh Street   | Signal                    |
| 40   | MPL02           | 302    | Hunter Street / Elizabeth Street / Chifley Square   | Signal                    |
| 41   | MPL03           | 1412   | Bent Street / Bligh Street                          | Signal                    |
| 42   | MPL04           | 242    | Bent Street / Phillip Street                        | Signal                    |
| 43   | MPL05           | 245    | Pedestrian Mid-block Crossing at Castlereagh Street | Pedestrian only - Signal  |
| 44   | MPL06           | 287    | Pedestrian Mid-block Crossing at Elizabeth Street   | Pedestrian only - Signal  |
| 45   | PIT01           | 2312   | Pitt Street / Bathurst Street                       | Signal                    |
| 46   | PIT02           | 2281   | Castlereagh Street / Bathurst Street                | Signal                    |
| 47   | PIT03           | 250    | Park Street / Castlereagh Street                    | Signal                    |
| 48   | PIT04           | 235    | Park Street / Pitt Street                           | Signal                    |
| 49   | CEN01           | 293    | Elizabeth Street / Eddy Avenue                      | Signal                    |
| 50   | CEN02           | 293    | Elizabeth Street / Foveaux Street                   | Signal                    |
| 51   | CEN03           | -      | Elizabeth Street / Cooper Street                    | Priority - Give Way       |
| 52   | CEN04           | -*     | New Pedestrian Mid-block Crossing at Randle Lane    | Pedestrian only - Signal  |
| 53   | CEN05           | 2916   | Elizabeth Street / Randle Street                    | Signal                    |
| 54   | WLO01           | 47     | Botany Road / Raglan Street / Henderson Road        | Signal                    |
| 55   | WLO02           | -      | Raglan Street / Cope Street                         | Roundabout                |
| 56   | WLO03           | 137    | Botany Road / Wellington Street / Buckland Street   | Signal                    |
| 57   | WLO04           | -      | Cope Street / Wellington Street                     | Roundabout                |
| 58   | WLO05           | 55     | Wyndham Street / Henderson Road                     | Signal                    |
| 59   | WLO06           | -*     | New Pedestrian Mid-block Crossing at Cope Street    | Pedestrian only - Signal  |
| 60   | SYD01           | 3320   | Railway Parade / Gleeson Avenue                     | Signal                    |
| 61   | SYD02           | 1152   | Burrows Avenue / Gleeson Avenue                     | Signal                    |
| 62   | SYD03           | -      | Burrows Avenue / George Street                      | Priority - Give Way       |
| 63   | SYD04           | 4946   | Pedestrian Mid-block Crossing at Sydenham Road      | Pedestrian only - Signal  |
| 64   | SYD05           | -      | Marrickville Road / Buckley Street                  | Priority - Give Way       |
| 65   | SYD06           | -      | Sydenham Road / Buckley Street                      | Priority - Give Way       |

\*Note: The new pedestrian mid-block crossings were under construction during Block 1 and were not assigned a TCS number.

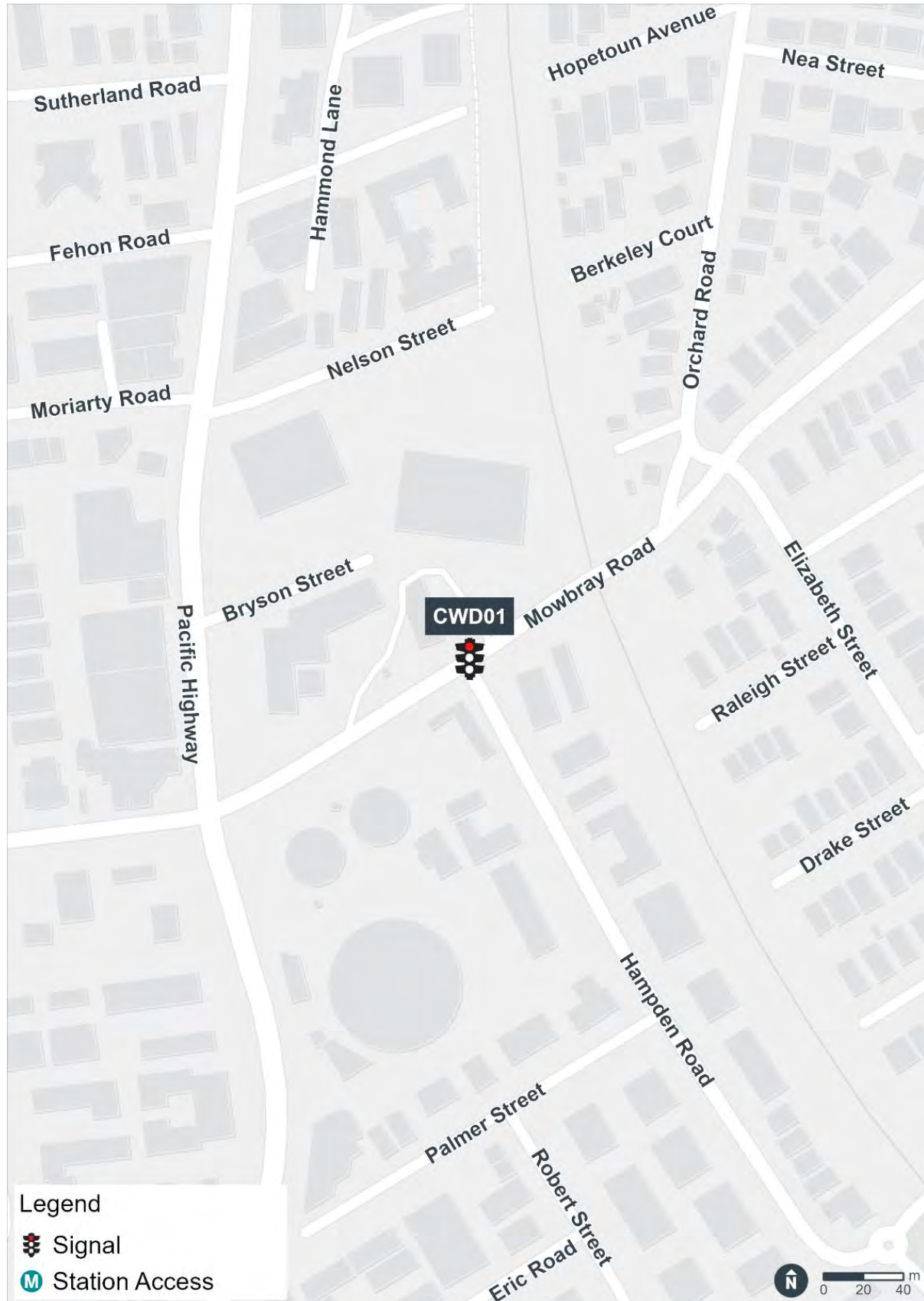

Figure 3-1 Block 1 – Chatswood Dive Site traffic study area





Figure 3-2 Block 1 – Crows Nest Station traffic study area

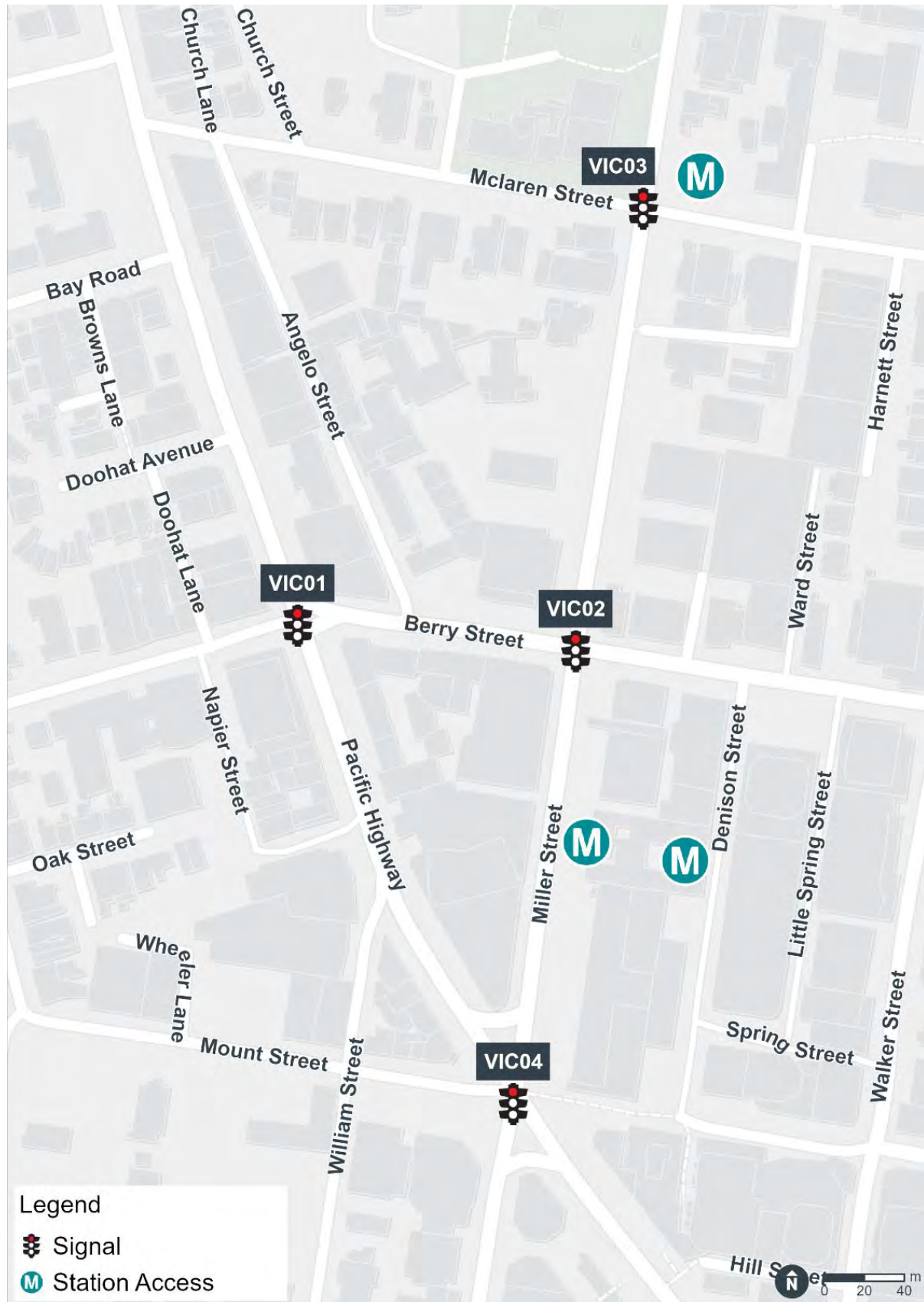

Figure 3-3 Block 1 – Victoria Cross Station traffic study area



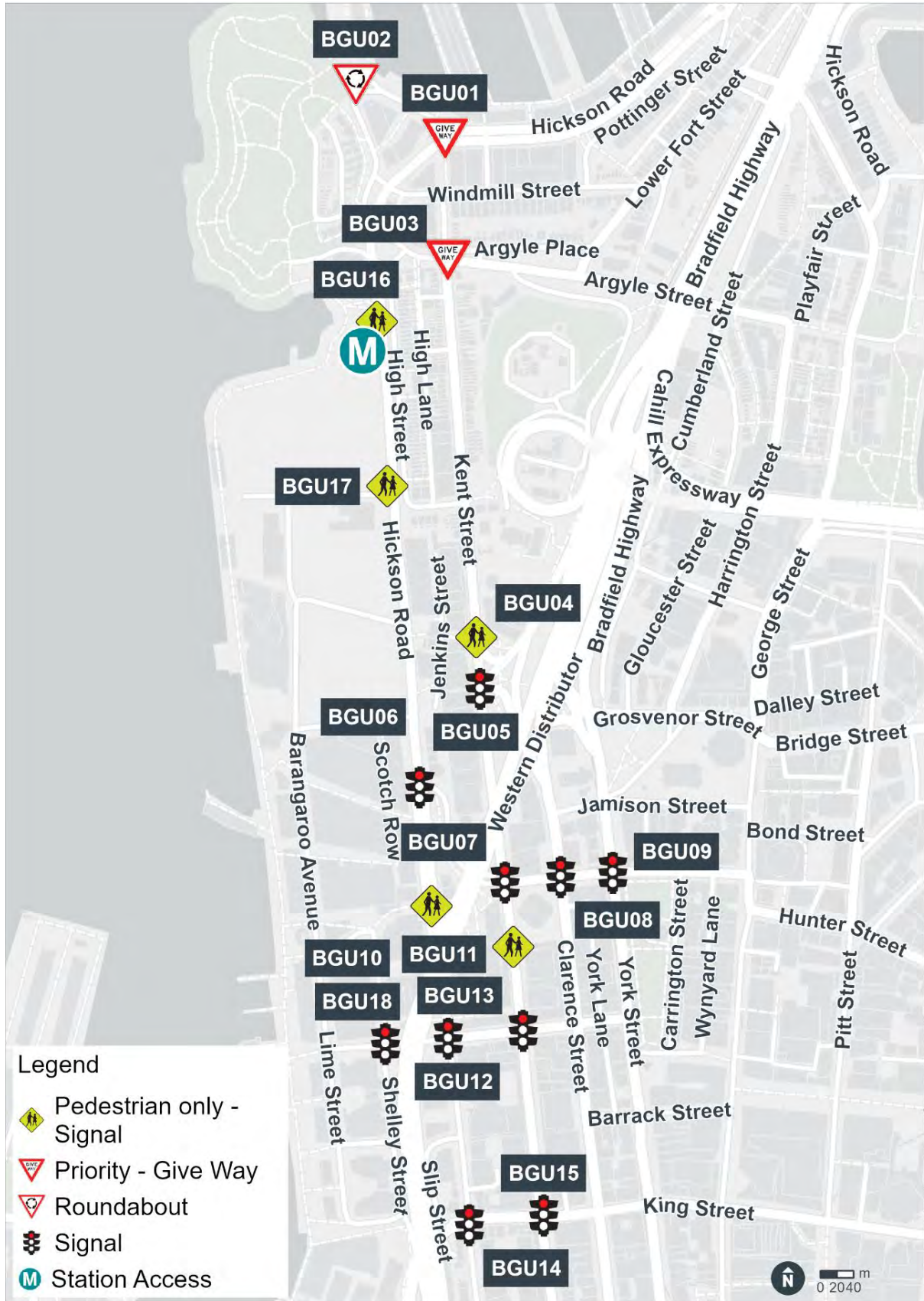

Figure 3-4 Block 1 – Barangaroo Station traffic study area

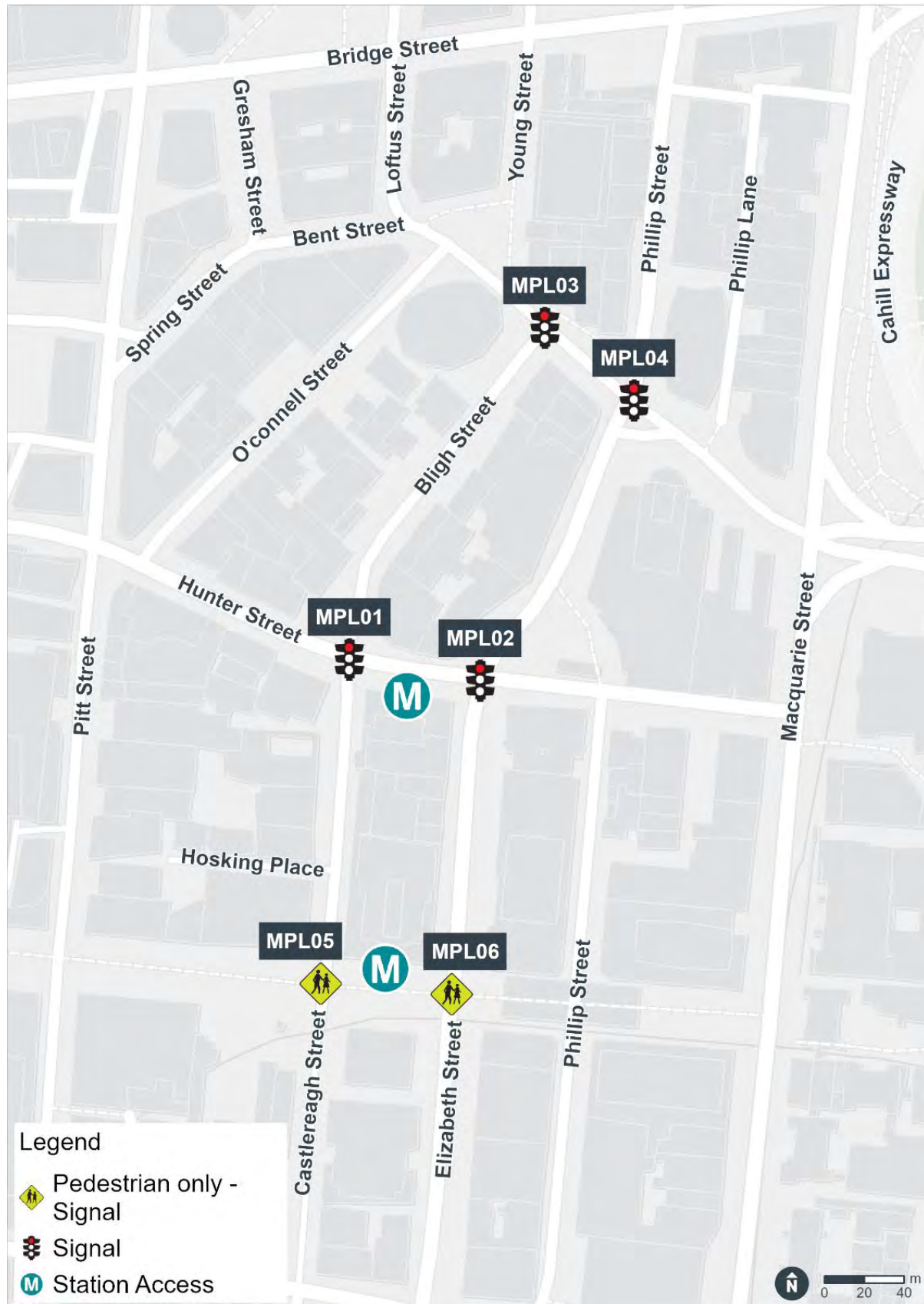

Figure 3-5 Block 1 – Martin Place Station traffic study area



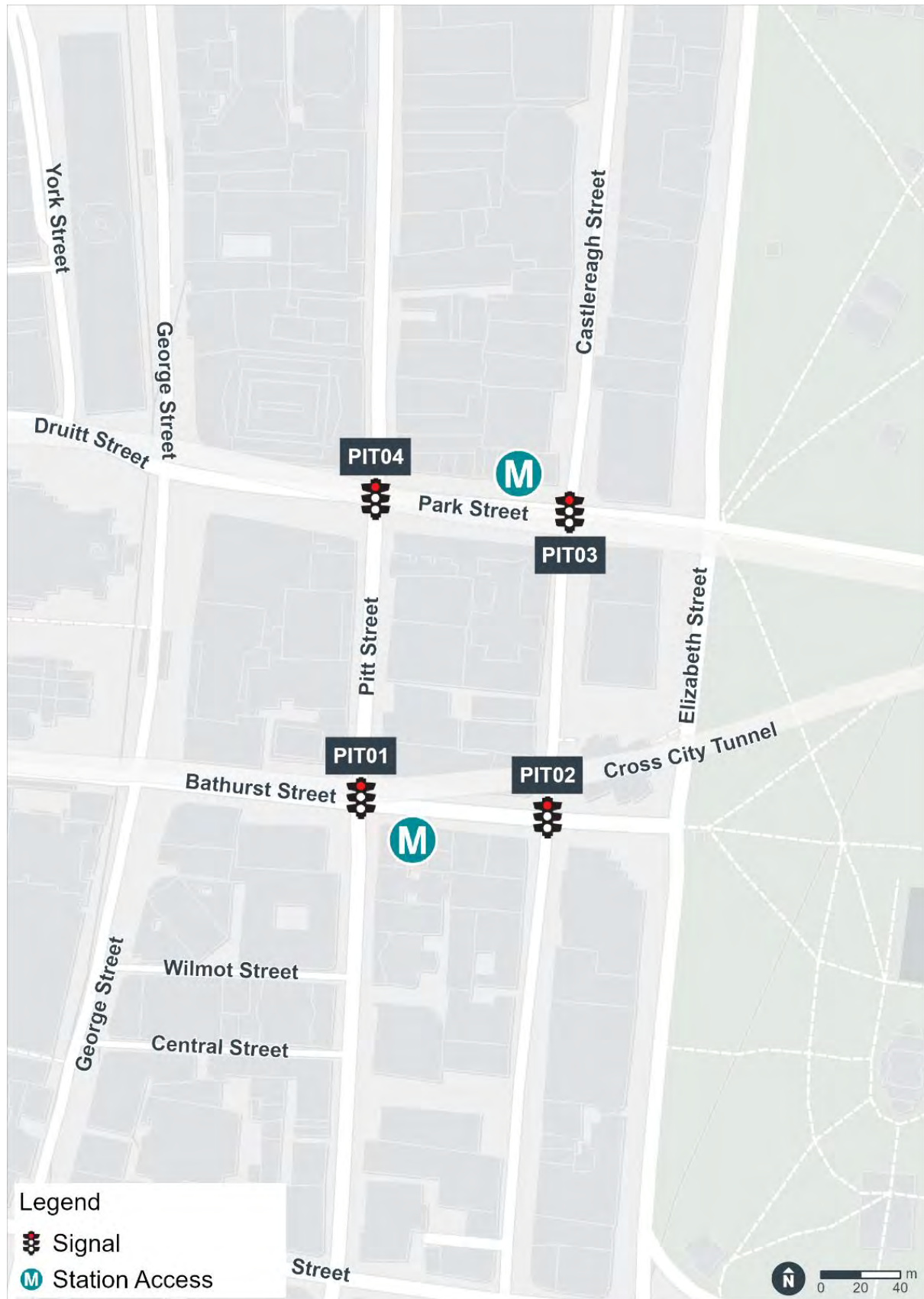

Figure 3-6 Block 1 – Pitt Street Station traffic study area

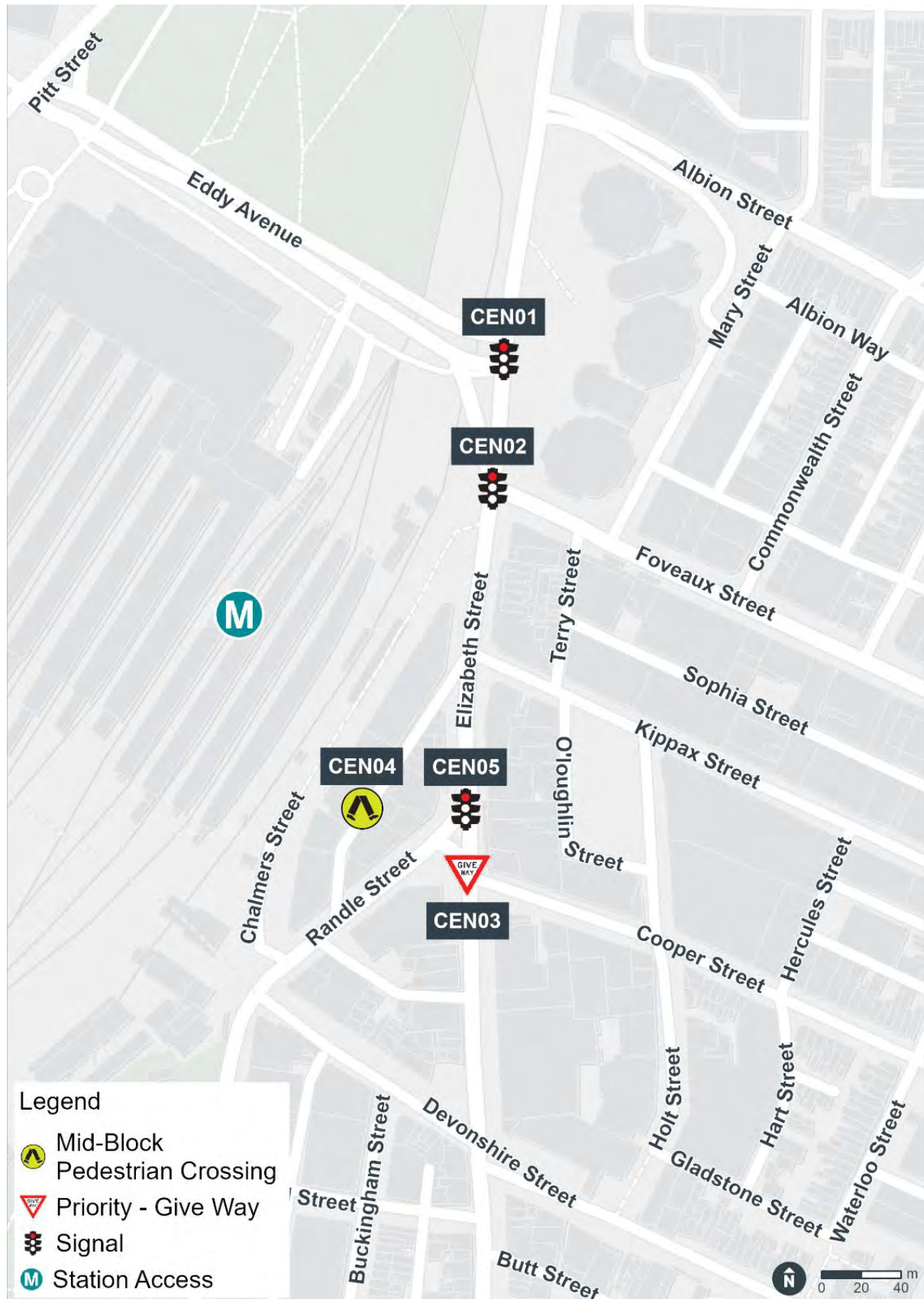

Figure 3-7 Block 1 – Central Station traffic study area





Figure 3-8 Block 1 – Waterloo Station traffic study area

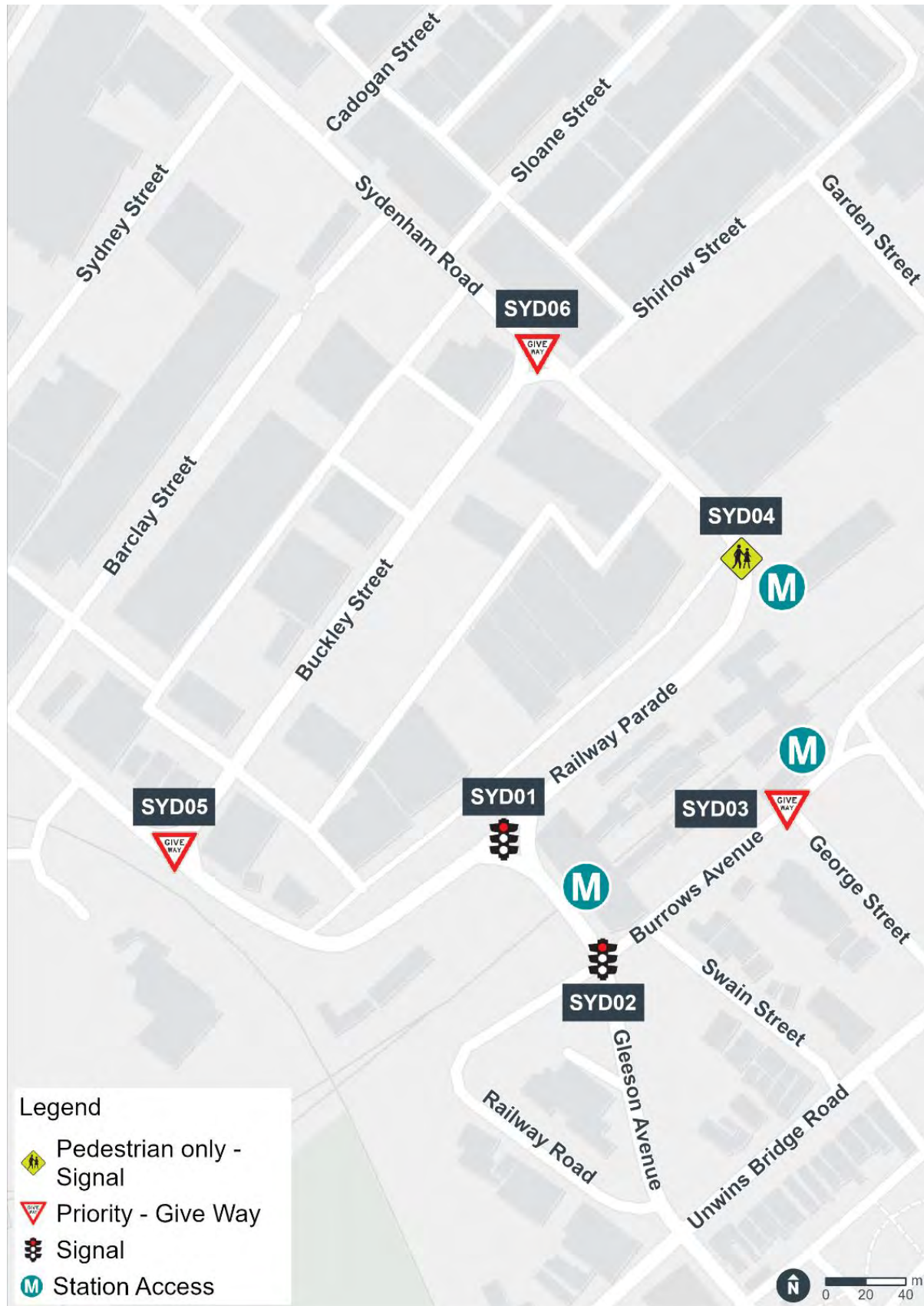

Figure 3-9 Block 1 – Sydenham Station traffic study area

### 3.3 Transport interchange monitoring

The transport interchange monitoring study area includes taxi, bus stop and kiss and ride facilities located near the nine stations along the City & Southwest Line (Chatswood to Sydenham). In Block 1, surveys were conducted only for facilities near operating interchanges, namely Chatswood Station and Sydenham Station.

Similar to the intersections in the traffic study area, a five-character identifier was assigned to each taxi, bus stop and kiss and ride facility for ease of referencing, with the first three-characters matching the station identifiers in **Table 3-1**. The fourth character identifies the type of interchange facility and the fifth character indexes it.

**Table 3-4** outlines the interchange facilities assessed in the Block 1 study, including the associated type, identifier, station, street and side of road location, and number of bays.

**Table 3-4 Block 1 – park and ride facilities**

| Type                        | ID    | Station   | Street           | Side of road | Number of bays |
|-----------------------------|-------|-----------|------------------|--------------|----------------|
| Kiss and ride               | CWDK1 | Chatswood | Railway Street   | West         | 1              |
| Kiss and ride               | CWDK2 | Chatswood | Albert Avenue    | North        | 2              |
| Kiss and ride               | CWDK3 | Chatswood | Endeavour Street | North        | 2              |
| Taxi                        | CWDT1 | Chatswood | Victoria Avenue  | North        | 11             |
| Taxi                        | CWDT2 | Chatswood | Endeavour Street | North        | 2              |
| Bus*                        | SYDB1 | Sydenham  | Railway Parade   | South        | 3              |
| Kiss and ride               | SYDK1 | Sydenham  | Burrows Avenue   | North        | 4              |
| Kiss and ride**             | SYDK2 | Sydenham  | Sydenham Road    | East         | 2              |
| Taxi                        | SYDT1 | Sydenham  | Burrows Avenue   | North        | 2              |
| Accessible kiss and ride*** | SYDA1 | Sydenham  | Bolton Street    | North        | 1              |

\*Note: SYDB1 encompasses transit stop number (TSN) 220421, TSN 2204125 and TSN 220450.

\*\*Note: SYDK2 is a proposed kiss and ride facility and did not operate as such during Block 1. It has been included as part of the Block 1 study for comparison with future study blocks.

\*\*\*Note: SYDA1 is a proposed accessible kiss and ride facility and operated as an accessible parking space during Block 1. It has been included as part of the Block 1 study for comparison with future study blocks.

**Figure 3-10** and **Figure 3-11** depict the location of each taxi, bus stop and kiss and ride facility assessed surrounding Chatswood Station and Sydenham Station, respectively.





Figure 3-10 Block 1 – Chatswood Station interchange study area

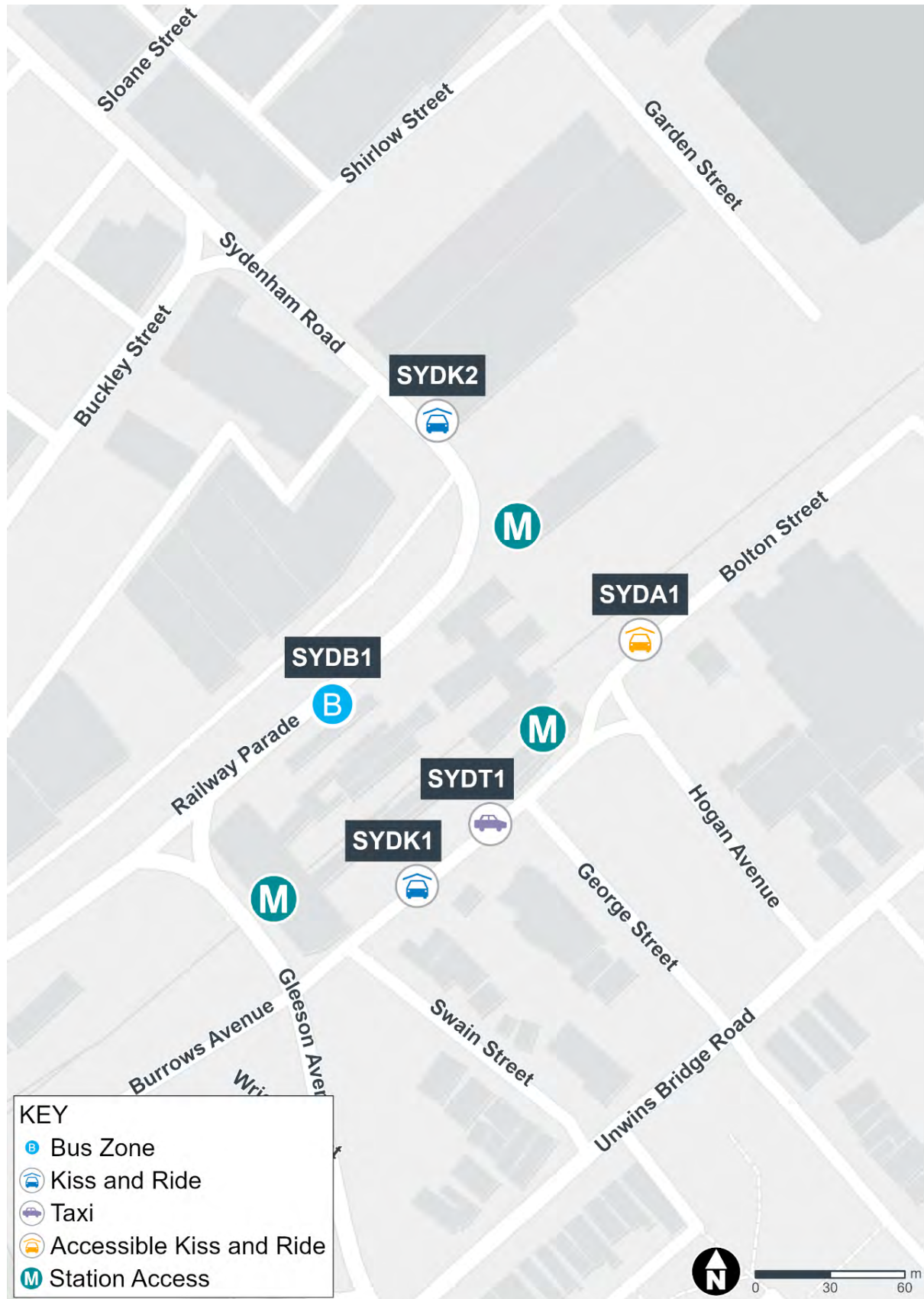

Figure 3-11 Sydenham Station interchange assessment study area

## 4.0 Assessment methodology

This section details the traffic and transport interchange monitoring assessment methodology undertaken for the intersections within study area and the park and ride facilities surrounding the stations identified in **Section 3.2** and **Section 3.3**, respectively.

### 4.1 Traffic monitoring

**Figure 4-1** provides an overview of the adopted methodology for the traffic monitoring, with further clarifications and details are provided in the subsequent sections.

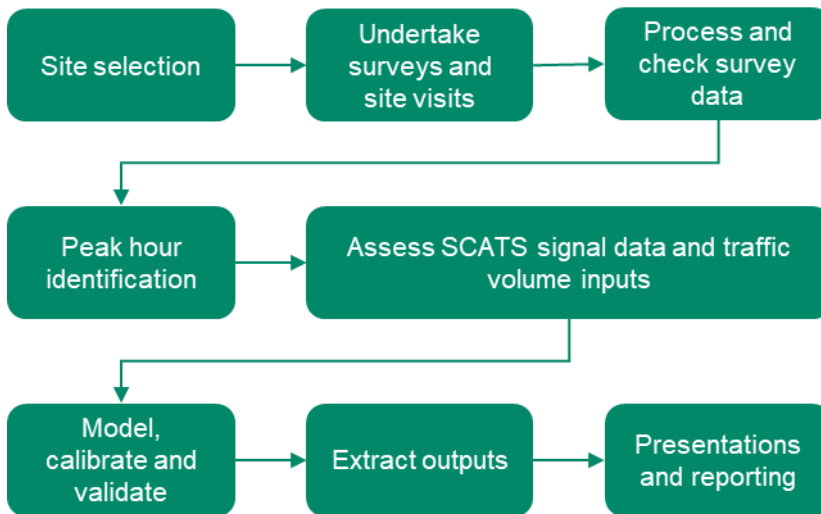

**Figure 4-1 Traffic assessment methodology overview**

#### 4.1.1 Traffic surveys

Classified intersection counts were undertaken for 61 of the 65 study area intersections (as outlined in **Section 3.2**). The traffic surveys were carried out over a one-week period, and the data was aggregated in 15-minute intervals. In cases where data was corrupted or unavailable due to vandalism, re-surveys were conducted. The survey dates were as follows:

- **Traffic Surveys:** Monday 27 March 2023 to Sunday 3 April 2023 or Tuesday 28 March 2023 to Monday 3 April 2023
- **Re-Surveys:** Monday 1 May 2023 to Sunday 7 May 2023.

During the traffic surveys, data was gathered for various vehicle types, such as light vehicles, heavy vehicles, and buses, as well as for cyclists and pedestrians. Furthermore, queue lengths were also documented during the traffic surveys to aid in validating the SIDRA Intersection models.

AECOM conducted site observations in conjunction with the traffic surveys, ensuring at least one observation was carried out for each intersection during each peak period specified in **Section 4.1.2** (excluding the Monday and Friday). The site observations were conducted to observe various aspects, including vehicle behaviours, any changes in lane geometry or capacity, and the condition of the traffic survey cameras to ensure that they were properly set up and not vandalised.

Sydney Coordinated Adaptive Traffic System (SCATS) traffic detector count data was provided by Sydney Metro, for the same dates traffic surveys were undertaken. The traffic survey data were reviewed against the SCATS traffic detector count data to identify any potential outliers. Intersections with traffic survey volumes greater than or less than 10 per cent of the SCATS volumes underwent additional investigation and / or recounting of the traffic surveys. Once the traffic survey data were reviewed and finalised, additional data analysis was conducted as detailed in the subsequent sections.

#### 4.1.2 Peak hour identification

Peak one-hour periods were identified for each intersection during three peak periods listed below:



- weekday AM peak: 6am–10am, Monday to Friday
- weekday PM peak: 3pm–7pm, Monday to Friday
- weekend peak: 10am–2pm, Saturday to Sunday.

It is important to note that the identified peak hour varies between different locations. However, the peak hours fall within the time periods listed above.

Each intersection was modelled as either an isolated site or as part of a network, as described in **Appendix B**. In the case of intersections modelled as an isolated site, the peak hour was determined by considering the total hourly volume (light vehicles, heavy vehicles, and buses) at the intersection. Conversely, for intersections modelled as part of a network, the peak hour was determined by considering the total hourly volume across the network at approaches connecting to the external network.

#### 4.1.3 Network flow diagrams

A review was undertaken to identify any variations in peak hour traffic volumes between mid-blocks connecting adjacent intersections within the same network. These variations were primarily due to minor counting discrepancies or due to side streets, property and parking access. In majority of the instances, survey volumes were used for the intersection modelling. However, for instances where there were no side streets, property or parking access, a conservative approach was adopted to balance the traffic volumes at such locations. Additionally, considering the fixed schedule of bus routes, adjustments were made to bus volumes whenever large discrepancies were observed.

The resulting peak hour volumes were utilised as the turning volume inputs for the SIDRA Intersection models. The network flow diagrams used to inform the traffic and pedestrian volume inputs for SIDRA Intersection modelling are included in **Appendix C**.

#### 4.1.4 SCATS signal and sub-systems data

In addition to the SCATS detector count data, SCATS traffic signal data was also provided for each intersection during their respective peak hours, which aligned with the traffic survey dates.

The SCATS traffic signal data included historical information on the signal phase sequence and signal phase time frequency, as well as sub-system information for signalised intersections modelled as a part of a network. Furthermore, the signal phase sequence was reviewed against traffic survey footage to determine if any signal phases were not executed or ran in a different order. Moreover, the traffic survey footage was also examined to ascertain whether the early cut-off or late-start movements, observed during site visits, also occurred during the peak hours modelled.

#### 4.1.5 SIDRA Intersection modelling

The performance of the intersections was assessed using either the site or network function (refer to **Appendix B**) of the SIDRA Intersection software, adopting the peak hour volumes, and SCATS traffic signal data. Detailed SIDRA Intersection modelling was conducted for the intersections within the study area. The geometry of the intersections was established using desktop aerial imagery from sources such as Nearmap and Google Streetview, which was then validated through on-site observations. The models were specifically developed for the identified peak hours within the peak periods (**Section 4.1.2**), incorporating the peak volume inputs derived from the network flow diagrams (**Section 4.1.3**), as well as the SCATS signal data and sub-systems information (**Section 4.1.4**).

The modelled queues were validated against the queue length surveys and traffic survey footage.

#### 4.1.6 Intersection performance assessment

The standard measure of intersection performance is vehicle delay, which is used to assess the efficiency of an intersection. SIDRA Intersection adopts the Transport for NSW Traffic Modelling Guidelines which categorises average intersection delay into six bands of average delay per vehicle (seconds per vehicle). These bands are determined based on the criteria outlined in **Table 4-1**. By analysing the average delay, SIDRA Intersection determines the level of service (LoS) for the intersection, a measure of the intersection performance.

Table 4-1 Intersection level of service criteria

| Level of service (LoS) | Average delay (seconds per vehicle) | Criteria for traffic signals                                | Criteria for give way and stop signs                     |
|------------------------|-------------------------------------|---|--|
| A                      | < 14                                | Good operation  | Good operation   |
| B                      | 15 to 28                            | Good operation with acceptable delays and spare capacity    | Good operation with acceptable delays and spare capacity |
| C                      | 29 to 42                            | Satisfactory  | Satisfactory, but accident study required                |
| D                      | 42 to 56                            | Near capacity   | Near capacity and accident study required                |
| E                      | 57 to 70                            | At capacity; at signals, incidents will cause excess delays | At capacity, requires other control mode                 |
| F                      | > 70                                | Extra capacity required                                     | At capacity, requires other control mode                 |

Source: TfNSW Traffic Modelling Guidelines, LOS definitions for vehicles (NSW method) based on delay only

It is noted that the critical movement for level of service at a roundabout or priority-controlled intersection is the movement with the worst delay, whereas for a signalised intersection, the average delay over all movements is adopted.

## 4.2 Transport interchange monitoring

Figure 4-2 provides an overview of the adopted methodology for the interchange monitoring, with further clarifications and details are provided in the subsequent sections.

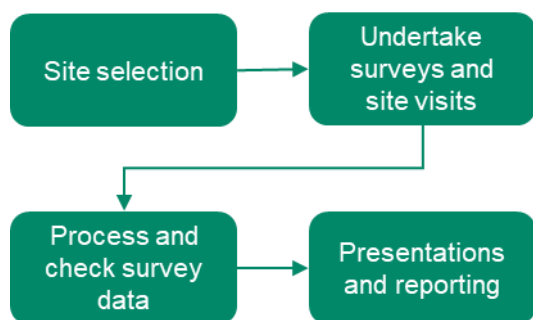

Figure 4-2 Interchange assessment methodology overview

### 4.2.1 Interchange surveys

Interchange surveys were undertaken at taxi, bus stop and kiss and ride facilities located at Chatswood Station and Sydenham Station (as outlined in Section 3.3).

The interchange surveys were carried out over a one-week period similar to intersection surveys, and re-surveys were conducted at sites where data was corrupted or unavailable due to vandalism. The survey dates are as follows:

- **Traffic Surveys:** Tuesday 28 March 2023 to Monday 3 April 2023
- **Re-Surveys:** Monday 1 May 2023 to Sunday 7 May 2023.

As part of the interchange surveys, data was gathered for the park and ride facilities, comprising bus bays/stops, taxi bays, and kiss and ride bays. The key data captured at each facility includes:

- vehicle counts
- vehicle occupancy (boarding and alighting passengers only)
- vehicle dwell time
- vehicle queue length outside the bay on a lane-by-lane basis.

Site observations were completed in conjunction with the interchange surveys, ensuring at least one observation was carried out for each park and ride facility during each of the following peak periods:

- weekday AM peak: 6am–10am, Tuesday to Thursday
- weekday PM peak: 3pm–7pm, Tuesday to Thursday
- weekend peak: 10am–2pm, Saturday to Sunday.

During the survey period, AECOM conducted site observations in conjunction with the data collection process. These observations aimed to monitor several aspects, such as kerbside lane usage, queuing outside the bays, and the condition of the interchange survey cameras, ensuring they were correctly set up and not subject to vandalism.

#### **4.2.2 Aggregation and analysis**

The interchange survey data was consolidated and analysed, categorising the data based on facility type (taxi, bus stop, or kiss and ride) to understand usage patterns at the park and ride facilities near the stations. A high-level exploratory analysis of the combined data was conducted to identify the daily vehicle trends for the key data types outlined in Section 4.2.1.

To ensure the accuracy and reliability of the findings, the identified trends were compared with the survey footage. In cases where discrepancies were detected, the survey data was recounted and/or rechecked to provide reliable results. The findings from this analysis are reported in Section 6.0.

## 5.0 Traffic monitoring and intersection performance

This section summarises the traffic monitoring and intersection performance outputs from traffic survey data and SIDRA Intersection modelling undertaken across the Block 1 study area.

**Appendix D** provides an overview of the average vehicle profile, traffic volumes, cyclist and pedestrian patterns for each station.

The SIDRA Intersection movement summary outputs for all modelled intersections during each peak period are shown in **Appendix E**.

### 5.1 Chatswood Dive Site

The Chatswood Dive Site is a temporary underground site facilitating excavation and construction works for the City & Southwest Line tunnel portal from Chatswood Station. Although not accessible to the general public, the Chatswood Dive Site facilitates the movement of workers and equipment to access the underground areas where crucial tunnelling and other metro construction operations take place. When the Sydney Metro City & Southwest Line (Chatswood to Sydenham) is operational, the Chatswood Dive Site will be used as a service facility for the operation of the Sydney Metro rail line between Chatswood and the Sydney CBD (and beyond).

The Chatswood Dive Site is located south of Chatswood Station and north of Artarmon Station, bound by the Pacific Highway (A1), Mowbray Road and Nelson Street in Chatswood. Bus services are available within approximately 200 metres west of the Chatswood Dive Site on the Pacific Highway (A1) and Mowbray Road. Artarmon Station, approximately 600 metres south of the Chatswood Dive Site, offers the nearest rail service. The pedestrian bridge crossing along Mowbray Road connects residents to the east with the Pacific Highway (A1), facilitating walking and cycling in addition to general traffic.

The Chatswood Dive Site study area consists of two study sites; however, the pedestrian bridge crossing along Mowbray Road (CWD02) was not modelled given it does not function as an intersection or mid-block crossing. **Table 5-1** presents the peak hours utilised for modelling the intersections.

**Table 5-2** provides a summary of the intersection level of service while

Figure 5-1 visualises a geospatial summary of the intersection level of service within the Chatswood Dive Site study area.

**Table 5-1 Block 1 – Chatswood Dive Site peak hours modelled**

| Network ID | Intersection ID | Weekday AM peak hour        |            | Weekday PM peak hour |            | Weekend peak hour |            |
|------------|-----------------|-----------------------------|------------|----------------------|------------|-------------------|------------|
|            |                 | Day                         | Start time | Day                  | Start time | Day               | Start time |
| -          | CWD01           | Wednesday                   | 8.15am     | Friday               | 3.15pm     | Saturday          | 11.15am    |
| -          | CWD02           | No modelling was undertaken |            |                      |            |                   |            |

**Table 5-2 Block 1 - Chatswood Dive Site intersection performance summary**

| Intersection ID | Intersection   | Level of service (LoS)       |                 |              |
|-----------------|--|------------------------------|-----------------|--------------|
|                 |  | Weekday AM Peak              | Weekday PM Peak | Weekend Peak |
| CWD01           | Mowbray Road / Hampden Road (Signal)                   | LOS A                        | LOS B           | LOS A        |
| CWD02           | Pedestrian Bridge Crossing along Mowbray Road (Bridge) | No modelling was undertaken. |                 |              |

Overall, in the Chatswood Dive Site study area, the intersection performance during the peak periods is satisfactory, operating at LOS B or better.

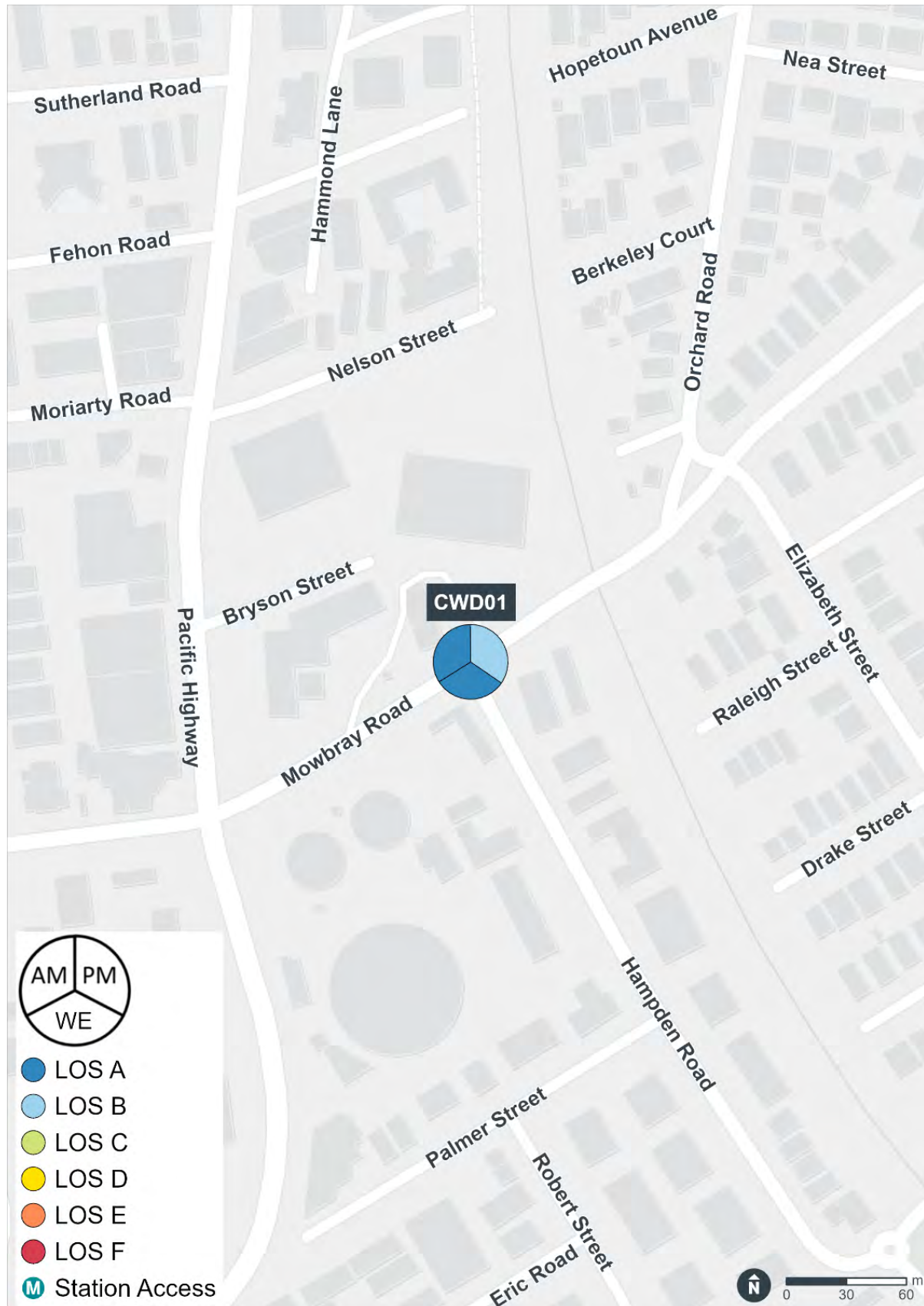

Figure 5-1 Block 1 - Chatswood Dive Site geospatial intersection performance summary



### 5.1.1 CWD01 – Mowbray Road / Hampden Road

This signalised intersection, composed of Mowbray Road, Hampden Road and the Chatswood Dive Site egress, is located directly south of the Chatswood Dive Site. This intersection serves as a connection point for the local road of Hampden Road, linking Chatswood and Artarmon, and the regional road of Mowbray Road, linking Willoughby to the Lane Cove. Furthermore, the Chatswood Dive Site exits on to Mowbray Road at this intersection. The pedestrian bridge crossing along Mowbray Road (CWD02) was modelled as part of eastern approach of this intersection.

**Figure 5-2** illustrates both the general intersection layout as modelled in SIDRA Intersection and the layout as per aerial imagery.

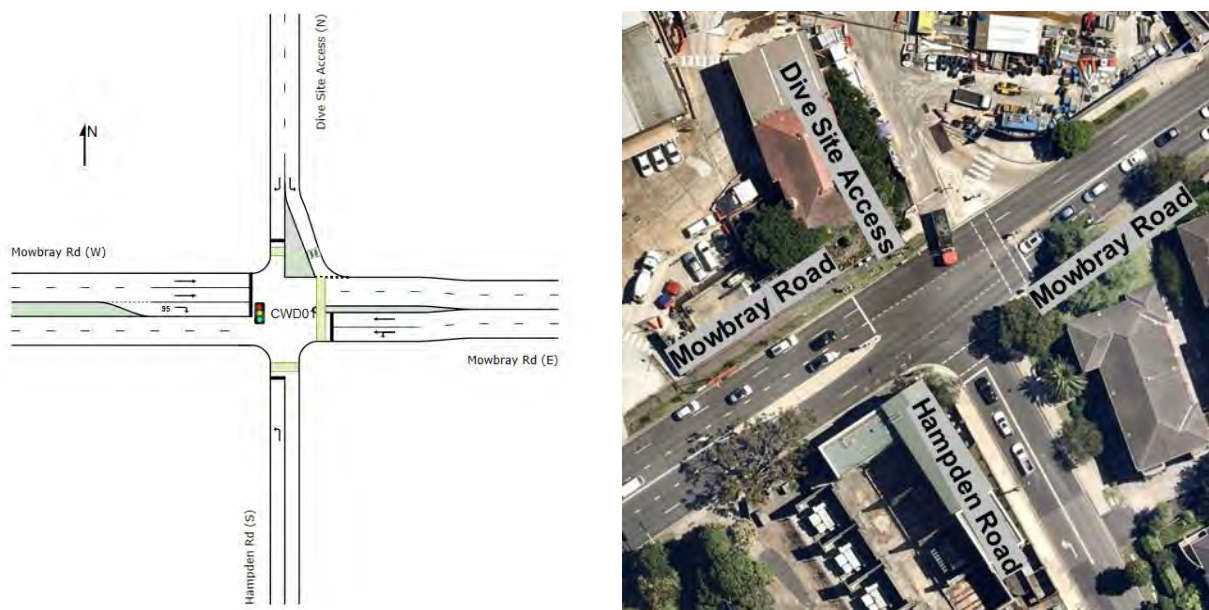

Source: Nearmap, accessed on 24 March 2023

**Figure 5-2** Block 1 - SIDRA Intersection layout (left) and Nearmap aerial imagery (right) of CWD01

**Table 5-3** presents a performance summary of this intersection.

**Table 5-3** Block 1 – Intersection performance summary of CWD01

| Intersection                                | Peak       | Approach     | Degree of saturation | Average delay (seconds) | 95 <sup>th</sup> percentile queue (metres) | Level of service (LOS) |
|---|------------|--------------|----------------------|-------------------------|--|------------------------|
| Mowbray Road / Hampden Road<br><br>(Signal) | Weekday AM | South        | 0.641                | 64.5                    | 105.7                                      | LOS E                  |
|   |            | East         | 0.409                | 12.2                    | 119.3                                      | LOS A                  |
|   |            | North        | 0.426                | 84.0                    | 6.0  | LOS F                  |
|   |            | West         | 0.531                | 4.3                     | 86.5                                       | LOS A                  |
|   |            | <b>Total</b> | <b>0.641</b>         | <b>12.9</b>             | <b>119.3</b>                               | <b>LOS A</b>           |
|   | Weekday PM | South        | 0.574                | 56.1                    | 89.4                                       | LOS D                  |
|   |            | East         | 0.555                | 16.3                    | 179.9                                      | LOS B                  |
|   |            | North        | 0.242                | 73.6                    | 6.3  | LOS F                  |
| West  |            | 0.445        | 5.2                  | 58.9                    | LOS A                                      |                        |



| Intersection | Peak    | Approach     | Degree of saturation | Average delay (seconds) | 95 <sup>th</sup> percentile queue (metres) | Level of service (LOS) |
|--------------|---------|--------------|----------------------|-------------------------|--|------------------------|
|              |         | <b>Total</b> | <b>0.574</b>         | <b>15.0</b>             | <b>179.9</b>                               | <b>LOS B</b>           |
|              |         | South        | 0.585                | 44.0                    | 100.2                                      | LOS D                  |
|              | Weekend | East         | 0.441                | 11.0                    | 106.0                                      | LOS A                  |
|              |         | North        | 0.002                | 2.6                     | 0.0  | LOS A                  |
|              |         | West         | 0.455                | 2.4                     | 45.0                                       | LOS A                  |
|              |         | <b>Total</b> | <b>0.585</b>         | <b>9.7</b>              | <b>106.0</b>                               | <b>LOS A</b>           |

Overall, the intersection of Mowbray Road and Hampden Road performs satisfactorily at LOS B or better. Mowbray Road (east approach) experiences consistent congestion, and vehicles often form queues that extend close to the intersection with Elizabeth Street and Orchard Road.

#### 5.1.2 CWD02 – Pedestrian Bridge Crossing along Mowbray Road

This pedestrian bridge, located east of the intersection of Mowbray Road and Hampden Road and south of the Chatswood Dive Site, provides passage along Mowbray Road for pedestrians, cyclists, and general traffic over the T1 North Shore & Western and T9 Northern rail lines. Mowbray Road is an east-west thoroughfare that connects Willoughby in the east to Lane Cove in the West, intersecting with key roads such as the Pacific Highway (A1).

The pedestrian bridge was not modelled in SIDRA Intersection as it does not function as an intersection or mid-block crossing. Rather it was modelled as an extension of the eastern approach of the intersection of Mowbray Road and Hampden Road (CWD01, refer to **Section 5.1.1**).

## 5.2 Crows Nest Station

Crows Nest Station is a new underground station and the second stop along the City & Southwest Line (towards Sydenham). It is located in the south-east area of the St Leonards strategic centre, bounded by the Pacific Highway (A1), Oxley Street and Clarke Street in Crows Nest.

Crows Nest Station was still under construction during Block 1. The construction zone incorporated Clarke Lane, south of Oxley Street, and Hume Street, between the Pacific Highway (A1) and Clarke Street. Construction access and egress to the station was facilitated through Clarke Lane at the intersection of Oxley Street and Clarke Lane, while residential access to Clarke Lane was provided at the intersection of Hume Street and Clarke Lane via Clarke Street.

Bus services are available within approximately 150 metres of Crows Nest Station. Bus stops located on the Pacific Highway (A1) facilitate connections to the external Sydney network, while bus stops on Willoughby Road connect to the internal Crows Nest centre. St Leonards Station, approximately 500 metres north-west from Crows Nest Station, offers the nearest rail service. Within a 50-metre distance of Crow Nest Station, an existing cycleway runs along Oxley Street and Clarke Street and pedestrian footpaths are available throughout Crows Nest.

The Crows Nest Station study area consists of 14 intersections. **Table 5-4** presents the peak hours utilised for modelling the intersections. **Table 5-5** provides a summary of the intersection level of service while **Figure 5-3** visualises a geospatial summary of the intersection level of service within the Crows Nest Station study area.

**Table 5-4 Block 1 - Crows Nest Station peak hours modelled**

| Network ID | Intersection ID | Weekday AM peak hour |            | Weekday PM peak hour |            | Weekend peak hour |            |
|------------|-----------------|----------------------|------------|----------------------|------------|-------------------|------------|
|            |                 | Day                  | Start time | Day                  | Start time | Day               | Start time |
| CST-N1     | CST01           | Wednesday            | 8.15am     | Tuesday              | 4.45pm     | Saturday          | 11.30am    |
|            | CST02           |                      |            |                      |            |                   |            |
|            | CST03           |                      |            |                      |            |                   |            |
|            | CST04           |                      |            |                      |            |                   |            |
|            | CST05           |                      |            |                      |            |                   |            |
|            | CST06           |                      |            |                      |            |                   |            |
|            | CST09           |                      |            |                      |            |                   |            |
|            | CST10           |                      |            |                      |            |                   |            |
|            | CST11           |                      |            |                      |            |                   |            |
|            | CST12           |                      |            |                      |            |                   |            |
|            | CST13           |                      |            |                      |            |                   |            |
| CST14      |                 |                      |            |                      |            |                   |            |
| -          | CST07           | Monday               | 8.30am     | Friday               | 5.45pm     | Saturday          | 11.45am    |
| -          | CST08           | Monday               | 8.15am     | Thursday             | 5.00pm     | Saturday          | 11.30am    |

**Table 5-5 Block 1 - Crows Nest Station intersection performance summary**

| Intersection ID | Intersection  | Level of service (LOS) |                 |              |
|-----------------|---|------------------------|-----------------|--------------|
|                 |   | Weekday AM Peak        | Weekday PM Peak | Weekend Peak |
| CST01           | Pacific Highway / Albany Street (Signal)                | LOS B                  | LOS C           | LOS C        |
| CST02           | Pacific Highway / Oxley Street (Signal)                 | LOS A                  | LOS B           | LOS B        |
| CST03           | Pacific Highway / Hume Street (Signal)                  | LOS A                  | LOS A           | LOS A        |
| CST04           | Pacific Highway / Falcon Street / Shirley Road (Signal) | LOS D                  | LOS C           | LOS C        |
| CST05           | Clarke Street / Oxley Street (Priority – Give Way)      | LOS A                  | LOS A           | LOS A        |
| CST06           | Clarke Street / Hume Street (Priority – Give Way)       | LOS A                  | LOS A           | LOS A        |
| CST07           | Clarke Street / Willoughby Road (Priority – Give Way)   | LOS A                  | LOS A           | LOS A        |
| CST08           | Albany Street / Willoughby Road (Signal)                | LOS B                  | LOS B           | LOS B        |
| CST09           | Albany Street / Oxley Street (Roundabout)               | LOS A                  | LOS B           | LOS A        |
| CST10           | Albany Street / Clarke Lane (Priority – Give Way)       | LOS C                  | LOS B           | LOS B        |
| CST11           | Oxley Street / Clarke Lane (Priority – Give Way)        | LOS A                  | LOS A           | LOS A        |
| CST12           | Hume Street / Clarke Lane (Priority – Stop)             | LOS A                  | LOS A           | LOS A        |
| CST13           | Pacific Highway / Alexander Street (Signal)             | LOS B                  | LOS B           | LOS B        |
| CST14           | Falcon Street / Alexander Street (Signal)               | LOS B                  | LOS B           | LOS B        |

Overall, in the Crows Nest Station study area, the intersection performance during the peak periods is satisfactory, operating at LOS C or better with the exception of the intersection of the Pacific Highway (A1), Falcon Street and Shirley Road (CST04). While CST04 performs satisfactorily at LOS C during both the weekday PM peak and weekend peak periods, its performance is nearing capacity at LOS D during the weekday AM peak period. **Section 5.2.4** provides further details of CST04 analysis outputs.

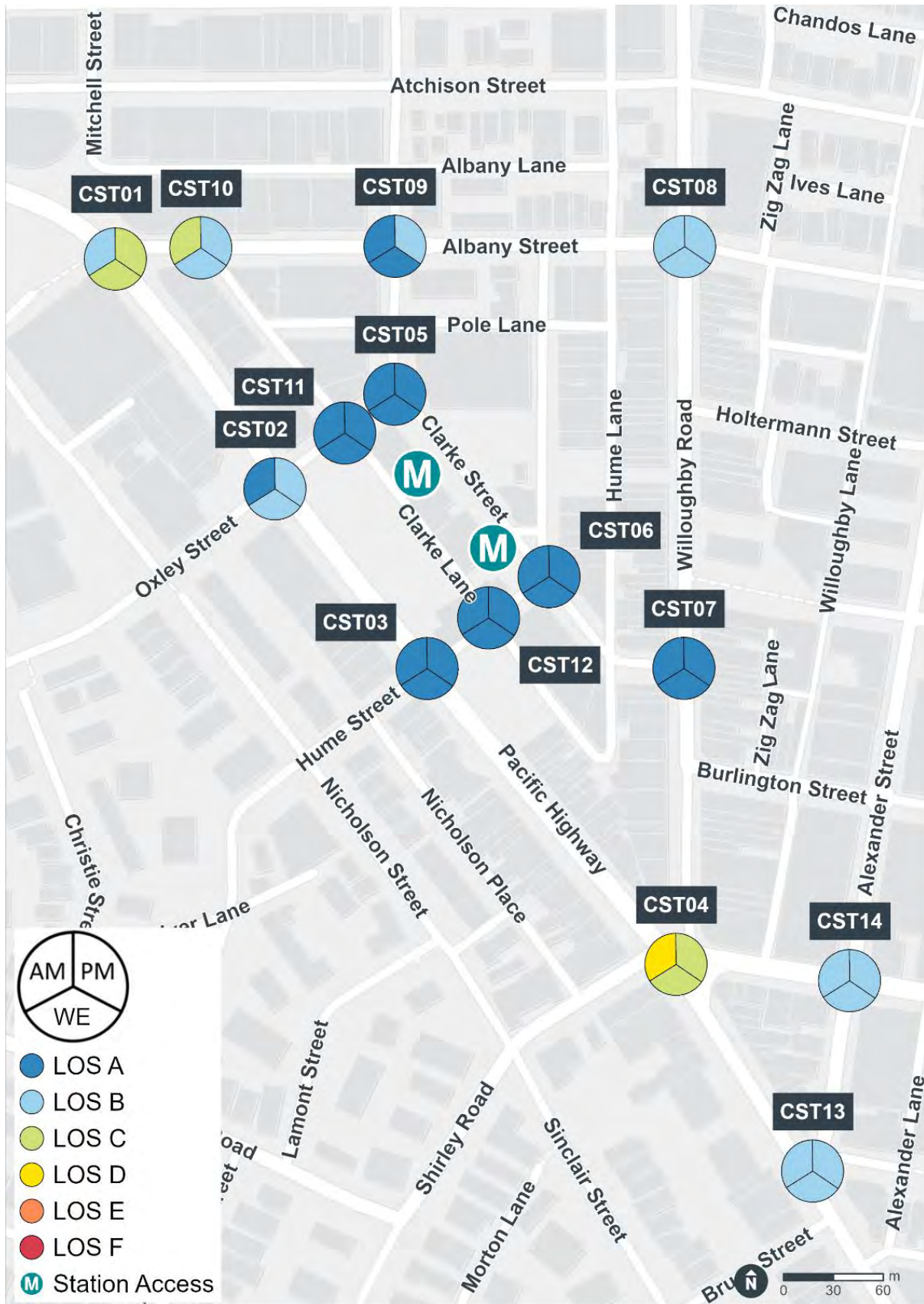

Figure 5-3 Block 1 – Crows Nest Station geospatial intersection performance summary



### 5.2.1 CST01 – Pacific Highway / Albany Street

This signalised intersection, composed of the Pacific Highway and Albany Street, is located north-west of Crows Nest Station. It connects the state road of the Pacific Highway (A1), linking Wahroonga and North Sydney, with the local road of Albany Street, linking Crows Nest and St Leonards.

Figure 5-4 illustrates both the general intersection layout as modelled in SIDRA Intersection and the layout as per aerial imagery.

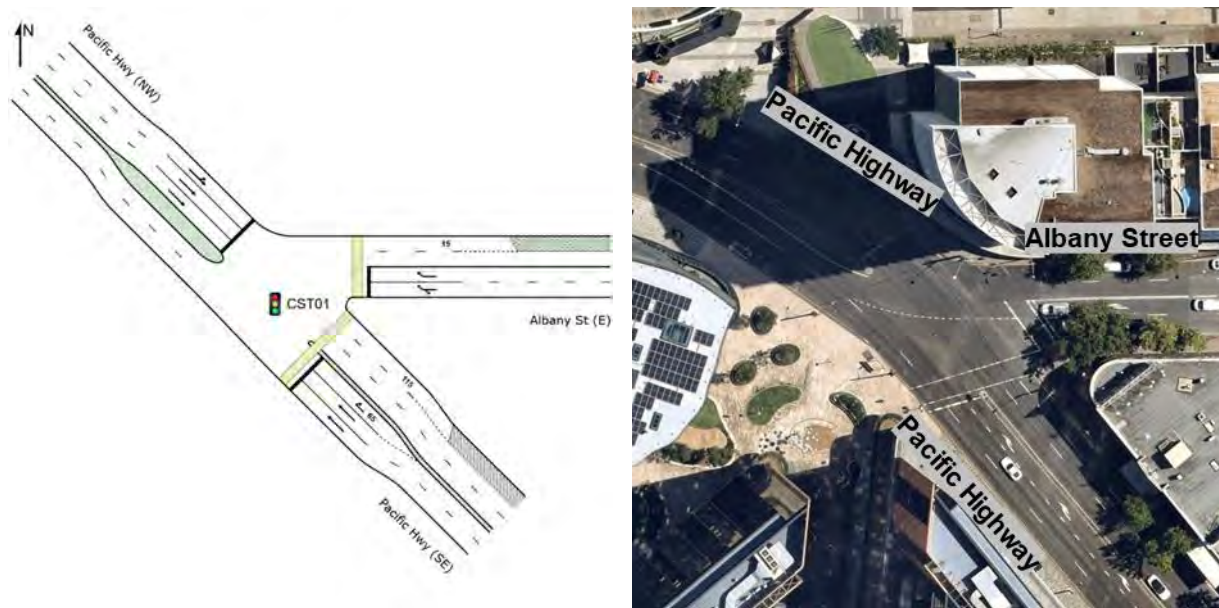

Source: Nearmap, accessed on 24 March 2023

Figure 5-4 Block 1 - SIDRA Intersection layout (left) and Nearmap aerial imagery (right) of CST01

Table 5-6 presents a performance summary of this intersection.

Table 5-6 Block 1 – Intersection performance summary of CST01

| Intersection                             | Peak       | Approach     | Degree of saturation | Average delay (seconds) | 95 <sup>th</sup> percentile queue (metres) | Level of service (LOS) |
|--|------------|--------------|----------------------|-------------------------|--|------------------------|
| Pacific Highway / Albany Street (Signal) | Weekday AM | South-east   | 0.851                | 15.2                    | 93.4                                       | LOS B                  |
|  |            | East         | 0.881                | 72.5                    | 49.0                                       | LOS F                  |
|  |            | North-west   | 0.596                | 17.1                    | 194.1                                      | LOS B                  |
|  |            | <b>Total</b> | <b>0.881</b>         | <b>25.0</b>             | <b>194.1</b>                               | <b>LOS B</b>           |
|  | Weekday PM | South-east   | 0.387                | 15.3                    | 128.3                                      | LOS B                  |
|  |            | East         | 0.889                | 68.2                    | 49.0                                       | LOS E                  |
|  |            | North-west   | 0.902                | 52.6                    | 227.7                                      | LOS D                  |
|  |            | <b>Total</b> | <b>0.902</b>         | <b>41.6</b>             | <b>227.7</b>                               | <b>LOS C</b>           |
|  | Weekend    | South-east   | 0.418                | 15.6                    | 150.4                                      | LOS B                  |
|  |            | East         | 0.903                | 74.0                    | 49.0                                       | LOS F                  |
|  |            | North-west   | 0.888                | 58.6                    | 182.0                                      | LOS E                  |
|  |            | <b>Total</b> | <b>0.903</b>         | <b>42.2</b>             | <b>182.0</b>                               | <b>LOS C</b>           |

Overall, the intersection of the Pacific Highway (A1) and Albany Street performs satisfactorily at LOS C or better. The 95<sup>th</sup> percentile queues on the Pacific Highway (A1) (north-west approach) extend back to Christie Street during all peak hours.

**5.2.2 CST02 – Pacific Highway / Oxley Street**

This signalised intersection, composed of Pacific Highway and Oxley Street, is located directly north-west of Crows Nest Station. It connects the local road of Oxley Street, linking St Leonards and Naremburn through Crows Nest, with the state road of Pacific Highway (A1), linking Wahroonga and North Sydney.

During Block 1, the south-eastern departure kerbside lane of the Pacific Highway (A1) was closed off due to Sydney Metro construction.

Figure 5-5 illustrates both the general intersection layout as modelled in SIDRA Intersection and the layout as per aerial imagery.

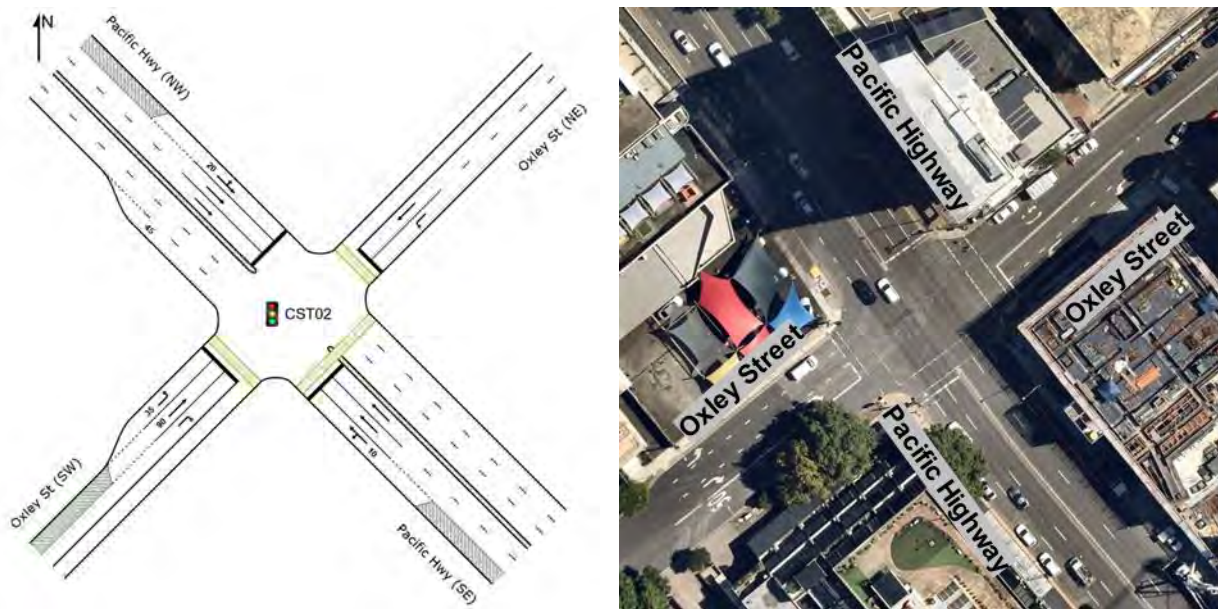

Source: Nearmap, accessed on 24 March 2023

Figure 5-5 Block 1 - SIDRA Intersection layout (left) and Nearmap aerial imagery (right) of CST02

Table 5-7 presents a performance summary of this intersection.

Table 5-7 Block 1 – Intersection performance summary of CST02

| Intersection                   | Peak       | Approach     | Degree of saturation | Average delay (seconds) | 95 <sup>th</sup> percentile queue (metres) | Level of service (LOS) |
|--------------------------------|------------|--------------|----------------------|-------------------------|--|------------------------|
| Pacific Highway / Oxley Street | Weekday AM | South-east   | 0.470                | 5.5                     | 53.4                                       | LOS A                  |
|                                |            | North-east   | 0.490                | 55.3                    | 49.0                                       | LOS D                  |
|                                |            | North-west   | 0.479                | 1.0                     | 19.5                                       | LOS A                  |
|                                |            | South-west   | 0.576                | 55.8                    | 60.2                                       | LOS D                  |
|                                |            | <b>Total</b> | <b>0.576</b>         | <b>13.3</b>             | <b>60.2</b>                                | <b>LOS A</b>           |
| (Signal)                       | Weekday PM | South-east   | 0.345                | 3.4                     | 41.1                                       | LOS A                  |
|                                |            | North-east   | 0.704                | 59.3                    | 49.0                                       | LOS E                  |
|                                |            | North-west   | 0.347                | 15.4                    | 131.6                                      | LOS B                  |



| Intersection | Peak    | Approach     | Degree of saturation | Average delay (seconds) | 95 <sup>th</sup> percentile queue (metres) | Level of service (LOS) |
|--------------|---------|--------------|----------------------|-------------------------|--|------------------------|
|              |         | South-west   | 0.930                | 82.2                    | 110.5                                      | LOS F                  |
|              |         | <b>Total</b> | <b>0.930</b>         | <b>26.6</b>             | <b>131.6</b>                               | <b>LOS B</b>           |
|              | Weekend | South-east   | 0.429                | 4.8                     | 53.6                                       | LOS A                  |
|              |         | North-east   | 0.472                | 62.5                    | 43.2                                       | LOS E                  |
|              |         | North-west   | 0.242                | 7.5                     | 63.8                                       | LOS A                  |
|              |         | South-west   | 0.810                | 74.2                    | 87.1                                       | LOS F                  |
|              |         | <b>Total</b> | <b>0.810</b>         | <b>20.4</b>             | <b>87.1</b>                                | <b>LOS B</b>           |

Overall, the intersection of the Pacific Highway and Oxley Street performs satisfactorily at LOS B or better. The 95<sup>th</sup> percentile queue lengths are accommodated within the approach distances for all approaches.

**5.2.3 CST03 – Pacific Highway / Hume Street**

This signalised intersection, composed of Pacific Highway and Hume Street, is located directly south-west of Crows Nest Station. It connects the state road of Pacific Highway (A1), linking Wahroonga and North Sydney, with the local road of Hume Street, linking Crows Nest and Wollstonecraft.

During Block 1, access to Hume Street (north-eastern approach) was closed due to Sydney Metro construction. Additionally, kerbside lane closures were observed along the Pacific Highway (A1), adjacent to the construction site, in the south-westbound direction of travel.

Figure 5-6 illustrates both the general intersection layout as modelled in SIDRA Intersection and the layout as per aerial imagery.



Source: Nemap, accessed on 24 March 2023

Figure 5-6 Block 1 - SIDRA Intersection layout (left) and Nemap aerial imagery (right) of CST03

Table 5-8 presents a performance summary of this intersection.

**Table 5-8 Block 1 – Intersection performance summary of CST03**

| Intersection                           | Peak       | Approach     | Degree of saturation | Average delay (seconds) | 95 <sup>th</sup> percentile queue (metres) | Level of service (LOS) |
|--|------------|--------------|----------------------|-------------------------|--|------------------------|
| Pacific Highway / Hume Street (Signal) | Weekday AM | South-east   | 0.377                | 0.7                     | 8.4  | LOS A                  |
|  |            | North-west   | 0.576                | 3.1                     | 108.2                                      | LOS A                  |
|  |            | South-west   | 0.396                | 64.3                    | 40.2                                       | LOS E                  |
|  |            | <b>Total</b> | <b>0.576</b>         | <b>4.9</b>              | <b>108.2</b>                               | <b>LOS A</b>           |
|  | Weekday PM | South-east   | 0.244                | 3.8                     | 52.6                                       | LOS A                  |
|  |            | North-west   | 0.384                | 0.8                     | 18.1                                       | LOS A                  |
|  |            | South-west   | 0.283                | 60.4                    | 23.7                                       | LOS E                  |
|  |            | <b>Total</b> | <b>0.384</b>         | <b>4.4</b>              | <b>52.6</b>                                | <b>LOS A</b>           |
|  | Weekend    | South-east   | 0.339                | 2.5                     | 53.6                                       | LOS A                  |
|  |            | North-west   | 0.294                | 0.5                     | 8.8  | LOS A                  |
|  |            | South-west   | 0.419                | 65.3                    | 33.6                                       | LOS E                  |
|  |            | <b>Total</b> | <b>0.419</b>         | <b>4.8</b>              | <b>53.6</b>                                | <b>LOS A</b>           |

Overall, the intersection of the Pacific Highway (A1) and Hume Street performs satisfactorily at LOS A. The 95th percentile queue lengths are accommodated within the approach distances for all approaches.

**5.2.4 CST04 – Pacific Highway / Falcon Street / Shirley Road**

This signalised intersection, composed of Pacific Highway, Falcon Street and Shirley Road, is located south-east of Crows Nest Station. It connects the state road of Pacific Highway (A1), linking Wahroonga to North Sydney, with the state road of Falcon Street, linking Crows Nest and Neutral Bay, and Shirley Road, linking Crows Nest and Wollstonecraft. Willoughby Road is an unsignalised approach, serving as an exit only route onto Falcon Street from the Crows Nest centre.

Figure 5-7 illustrates both the general intersection layout as modelled in SIDRA Intersection and the layout as per aerial imagery.

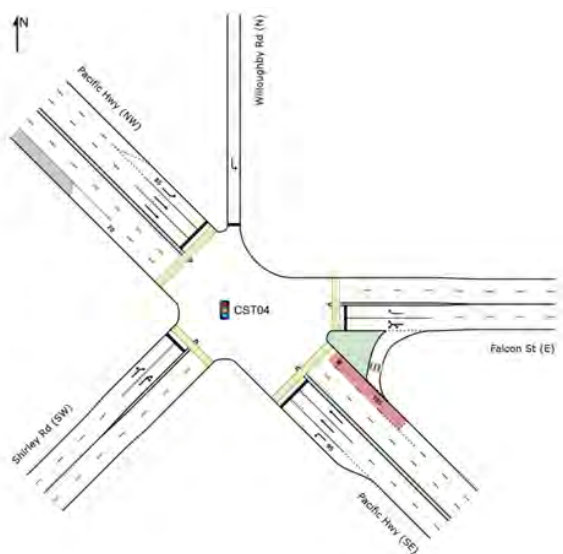

Source: Nearmap, accessed on 24 March 2023

**Figure 5-7 Block 1 - SIDRA Intersection layout (left) and Nearmap aerial imagery (right) of CST04**

**Table 5-9** presents a performance summary of this intersection.

**Table 5-9 Block 1 - Intersection performance summary of CST04**

| Intersection   | Peak       | Approach     | Degree of saturation | Average delay (seconds) | 95 <sup>th</sup> percentile queue (metres) | Level of service (LOS) |
|--|------------|--------------|----------------------|-------------------------|--|------------------------|
| Pacific Highway / Falcon Street / Shirley Road<br>(Signal) | Weekday AM | South-east   | 0.537                | 27.1                    | 138.9                                      | LOS B                  |
|  |            | East         | 0.978                | 78.4                    | 130.6                                      | LOS F                  |
|  |            | North        | 0.027                | 3.8                     | 1.1  | LOS A                  |
|  |            | North-west   | 0.805                | 33.5                    | 234.3                                      | LOS C                  |
|  |            | South-west   | 0.862                | 64.9                    | 182.4                                      | LOS E                  |
|  |            | <b>Total</b> | <b>0.978</b>         | <b>45.2</b>             | <b>234.3</b>                               | <b>LOS D</b>           |
|  | Weekday PM | South-east   | 0.537                | 30.9                    | 139.3                                      | LOS C                  |
|  |            | East         | 0.944                | 36.0                    | 130.6                                      | LOS C                  |
|  |            | North        | 0.026                | 3.8                     | 1.2  | LOS A                  |
|  |            | North-west   | 0.556                | 12.2                    | 61.8                                       | LOS A                  |
|  |            | South-west   | 0.963                | 84.6                    | 169.3                                      | LOS F                  |
|  |            | <b>Total</b> | <b>0.963</b>         | <b>35.1</b>             | <b>169.3</b>                               | <b>LOS C</b>           |
|  | Weekend    | South-east   | 0.605                | 31.1                    | 124.2                                      | LOS C                  |
|  |            | East         | 0.897                | 38.7                    | 130.6                                      | LOS C                  |
|  |            | North        | 0.017                | 3.7                     | 0.7  | LOS A                  |
|  |            | North-west   | 0.544                | 15.7                    | 65.2                                       | LOS B                  |
|  |            | South-west   | 0.966                | 86.0                    | 248.8                                      | LOS F                  |
|  |            | <b>Total</b> | <b>0.966</b>         | <b>41.7</b>             | <b>248.8</b>                               | <b>LOS C</b>           |

Overall, the intersection of the Pacific Highway (A1), Falcon Street, and Shirley Road performs at near capacity at LOS D or better. The 95<sup>th</sup> percentile queues on both the Pacific Highway (A1) (south-east approach) and Falcon Street (east approach) extend back to Alexander Street during all peak hours. Similarly, the 95<sup>th</sup> percentile queue on Shirley Road (south-west approach) extends back to River Road during the weekend peak hour.

### 5.2.5 CST05 – Clarke Street / Oxley Street

This priority intersection, composed of Oxley Street and Clarke Street, is located directly north of Crows Nest Station. It connects the local roads of Clarke Street in Crows Nest and Oxley Street, linking Wollstonecraft and Naremburn through Crows Nest.

**Figure 5-8** illustrates both the general intersection layout as modelled in SIDRA Intersection and the layout as per aerial imagery.

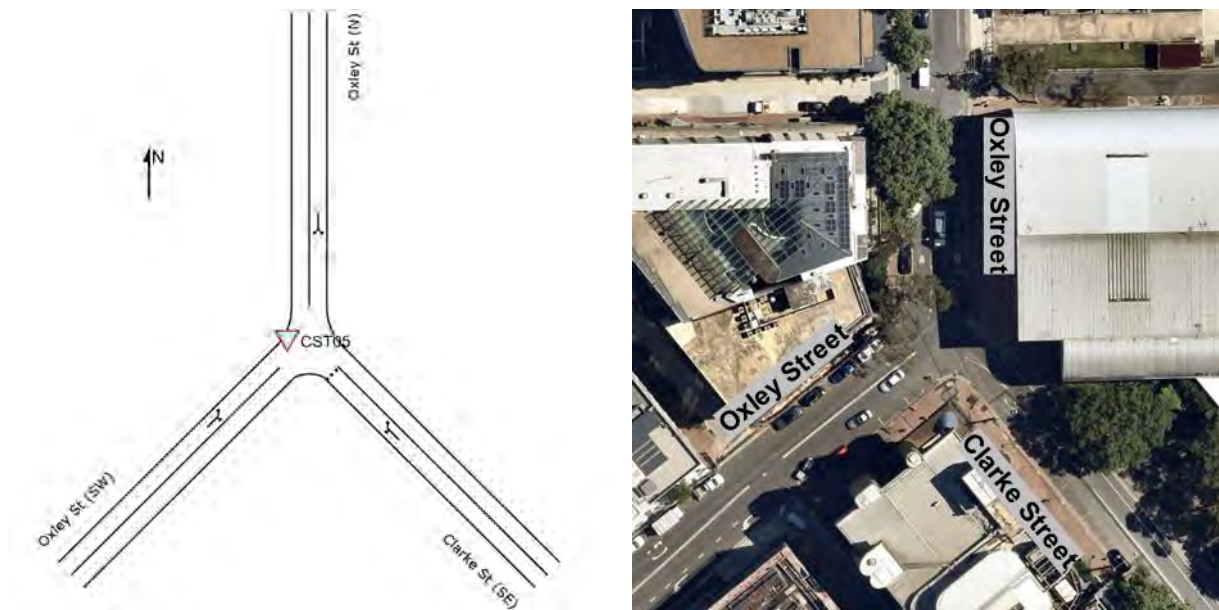

Source: Nearmap, accessed on 24 March 2023

Figure 5-8 Block 1 - SIDRA Intersection layout (left) and Nearmap aerial imagery (right) of CST05

Table 5-10 presents a performance summary of this intersection.

Table 5-10 Block 1 - Intersection performance summary of CST05

| Intersection  | Peak       | Approach     | Degree of saturation | Average delay (seconds) | 95 <sup>th</sup> percentile queue (metres) | Level of service (LOS) |
|---|------------|--------------|----------------------|-------------------------|--|------------------------|
| Clarke Street / Oxley Street<br>(Priority – Give Way) | Weekday AM | South-east   | 0.079                | 6.3                     | 1.9  | LOS A                  |
|   |            | North        | 0.173                | 4.4                     | 0.0  | LOS A                  |
|   |            | South-west   | 0.137                | 5.3                     | 3.9  | LOS A                  |
|   |            | <b>Total</b> | <b>0.079</b>         | <b>6.3</b>              | <b>1.9</b>                                 | <b>LOS A</b>           |
|   | Weekday PM | South-east   | 0.109                | 6.4                     | 2.7  | LOS A                  |
|   |            | North        | 0.185                | 4.4                     | 0.0  | LOS A                  |
|   |            | South-west   | 0.149                | 5.6                     | 4.1  | LOS A                  |
|   |            | <b>Total</b> | <b>0.109</b>         | <b>6.4</b>              | <b>2.7</b>                                 | <b>LOS A</b>           |
|   | Weekend    | South-east   | 0.095                | 5.7                     | 2.4  | LOS A                  |
|   |            | North        | 0.147                | 4.4                     | 0.0  | LOS A                  |
|   |            | South-west   | 0.113                | 5.0                     | 3.0  | LOS A                  |
|   |            | <b>Total</b> | <b>0.095</b>         | <b>5.7</b>              | <b>2.4</b>                                 | <b>LOS A</b>           |

Overall, the intersection of Clarke Street and Oxley Street performs satisfactorily at LOS A. The 95th percentile queue lengths are accommodated within the approach distances for all approaches.

**5.2.6 CST06 – Clarke Street / Hume Street**

This priority intersection, composed of Clarke Street and Hume Street, is located directly north-east of Crows Nest Station. It connects the local roads of Clarke Street in Crows Nest and Hume Street, linking Crows Nest and Wollstonecraft.



During Block 1, access to Hume Street (south-west approach) was limited to residential access and transportation of construction materials only. Additionally, access to the Hume Street (north approach) was prohibited. During the weekday AM peak period, Clarke Street (south-east approach) was observed to operate as a two-way one-lane road under controlled conditions, managed by on-site traffic controllers. Similarly, traffic control was observed at the intersection to facilitate construction vehicle movements.

**Figure 5-9** illustrates both the general intersection layout as modelled in SIDRA Intersection and the layout as per aerial imagery.



Source: Nemap, accessed on 24 March 2023

**Figure 5-9** Block 1 - SIDRA Intersection layout (left) and Nemap aerial imagery (right) of CST06

**Table 5-11** presents a performance summary of this intersection.

**Table 5-11** Block 1 - Intersection performance summary of CST06

| Intersection   | Peak       | Approach     | Degree of saturation | Average delay (seconds) | 95 <sup>th</sup> percentile queue (metres) | Level of service (LOS) |
|--|------------|--------------|----------------------|-------------------------|--|------------------------|
| Clarke Street / Hume Street<br>(Priority – Give Way) | Weekday AM | South-east   | 0.033                | 4.6                     | 0.0  | LOS A                  |
|  |            | North-west   | 0.052                | 4.9                     | 0.6  | LOS A                  |
|  |            | South-west   | 0.008                | 3.9                     | 0.1  | LOS A                  |
|  |            | <b>Total</b> | <b>0.052</b>         | <b>4.9</b>              | <b>0.6</b>                                 | <b>LOS A</b>           |
|  | Weekday PM | South-east   | 0.062                | 4.6                     | 0.0  | LOS A                  |
|  |            | North-west   | 0.124                | 4.7                     | 0.1  | LOS A                  |
|  |            | South-west   | 0.034                | 4.5                     | 0.4  | LOS A                  |
|  |            | <b>Total</b> | <b>0.124</b>         | <b>4.7</b>              | <b>0.1</b>                                 | <b>LOS A</b>           |
|  | Weekend    | South-east   | 0.068                | 4.6                     | 0.0  | LOS A                  |
|  |            | North-west   | 0.103                | 4.6                     | 0.1  | LOS A                  |
|  |            | South-west   | 0.005                | 4.3                     | 0.1  | LOS A                  |
|  |            | <b>Total</b> | <b>0.068</b>         | <b>4.6</b>              | <b>0.0</b>                                 | <b>LOS A</b>           |

Overall, the intersection of Clarke Street and Hume Street performs satisfactorily at LOS A. The 95th percentile queue lengths are accommodated within the approach distances for all approaches.

**5.2.7 CST07 – Clarke Street / Willoughby Road**

This priority intersection, composed of Clarke Street and Willoughby Road, is located east of Crows Nest Station. It connects the local roads of Clarke Street in Crows Nest and Willoughby Road, linking Crows Nest and Willoughby.

**Figure 5-10** illustrates both the general intersection layout as modelled in SIDRA Intersection and the layout as per aerial imagery.



Source: Nearmap, accessed on 24 March 2023

**Figure 5-10 Block 1 - SIDRA Intersection layout (left) and Nearmap aerial imagery (right) of CST07**

**Table 5-12** presents a performance summary of this intersection.

**Table 5-12 Block 1 - Intersection performance summary of CST07**

| Intersection   | Peak       | Approach     | Degree of saturation | Average delay (seconds) | 95 <sup>th</sup> percentile queue (metres) | Level of service (LOS) |
|--|------------|--------------|----------------------|-------------------------|--|------------------------|
| Clarke Street / Willoughby Road<br>(Priority – Give Way) | Weekday AM | South        | 0.264                | 3.8                     | 10.7                                       | LOS A                  |
|  |            | North        | 0.206                | 6.6                     | 7.0  | LOS A                  |
|  |            | West         | 0.134                | 6.2                     | 3.5  | LOS A                  |
|  |            | <b>Total</b> | <b>0.206</b>         | <b>6.6</b>              | <b>7.0</b>                                 | <b>LOS A</b>           |
|  | Weekday PM | South        | 0.230                | 4.1                     | 8.3  | LOS A                  |
|  |            | North        | 0.293                | 7.9                     | 9.2  | LOS A                  |
|  |            | West         | 0.198                | 6.2                     | 5.2  | LOS A                  |
|  |            | <b>Total</b> | <b>0.293</b>         | <b>7.9</b>              | <b>9.2</b>                                 | <b>LOS A</b>           |
|  | Weekend    | South        | 0.222                | 4.0                     | 7.9  | LOS A                  |
|  |            | North        | 0.264                | 7.4                     | 8.5  | LOS A                  |
|  |            | West         | 0.190                | 6.2                     | 5.0  | LOS A                  |
|  |            | <b>Total</b> | <b>0.264</b>         | <b>7.4</b>              | <b>8.5</b>                                 | <b>LOS A</b>           |

Overall, the intersection of Clarke Street and Willoughby Road performs satisfactorily at LOS A. The 95th percentile queue lengths are accommodated within the approach distances for all approaches.

**5.2.8 CST08 – Albany Street / Willoughby Road**

This signalised intersection, composed of Albany Street and Willoughby Road, is located north-east of Crows Nest Station. It connects the local roads of Albany Street, linking Crows Nest and St Leonards, and Willoughby Road, linking Crows Nest and Willoughby.

**Figure 5-11** illustrates both the general intersection layout as modelled in SIDRA Intersection and the layout as per aerial imagery.

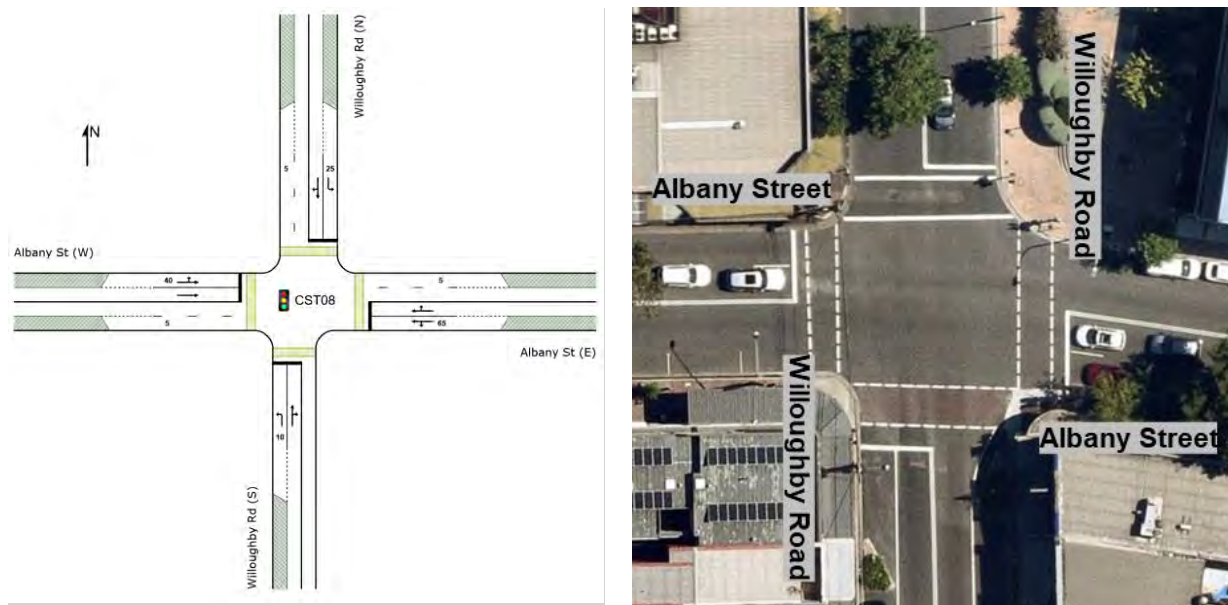

Source: Nearmap, accessed on 24 March 2023

**Figure 5-11 Block 1 - SIDRA Intersection layout (left) and Nearmap aerial imagery (right) of CST08**

**Table 5-13** presents a performance summary of this intersection.

**Table 5-13 Block 1 - Intersection performance summary of CST08**

| Intersection                             | Peak       | Approach     | Degree of saturation | Average delay (seconds) | 95 <sup>th</sup> percentile queue (metres) | Level of service (LOS) |
|--|------------|--------------|----------------------|-------------------------|--|------------------------|
| Albany Street / Willoughby Road (Signal) | Weekday AM | South        | 0.343                | 31.4                    | 37.1                                       | LOS C                  |
|  |            | East         | 0.481                | 16.0                    | 51.4                                       | LOS B                  |
|  |            | North        | 0.373                | 22.3                    | 44.9                                       | LOS B                  |
|  |            | West         | 0.400                | 18.7                    | 61.9                                       | LOS B                  |
|  |            | <b>Total</b> | <b>0.481</b>         | <b>20.7</b>             | <b>61.9</b>                                | <b>LOS B</b>           |
|  | Weekday PM | South        | 0.323                | 35.6                    | 31.4                                       | LOS C                  |
|  |            | East         | 0.480                | 14.7                    | 45.9                                       | LOS B                  |
|  |            | North        | 0.371                | 24.5                    | 41.7                                       | LOS B                  |
|  |            | West         | 0.391                | 17.3                    | 62.6                                       | LOS B                  |
|  |            | <b>Total</b> | <b>0.480</b>         | <b>20.5</b>             | <b>62.6</b>                                | <b>LOS B</b>           |
|  | Weekend    | South        | 0.315                | 30.3                    | 32.4                                       | LOS C                  |

| Intersection | Peak | Approach     | Degree of saturation | Average delay (seconds) | 95 <sup>th</sup> percentile queue (metres) | Level of service (LOS) |
|--------------|------|--------------|----------------------|-------------------------|--|------------------------|
|              |      | East         | 0.623                | 18.3                    | 78.3                                       | LOS B                  |
|              |      | North        | 0.362                | 21.5                    | 43.7                                       | LOS B                  |
|              |      | West         | 0.371                | 19.3                    | 55.8                                       | LOS B                  |
|              |      | <b>Total</b> | <b>0.623</b>         | <b>21.3</b>             | <b>78.3</b>                                | <b>LOS B</b>           |

Overall, the intersection of Albany Street and Willoughby Road performs satisfactorily at LOS B or better. The 95th percentile queue lengths are accommodated within the approach distances for all approaches.

**5.2.9 CST09 – Albany Street / Oxley Street**

This roundabout composed of Albany Street and Oxley Street, is located north of Crows Nest Station. It connects the local roads of Albany Street, linking Crows Nest and St Leonards, and Oxley Street, linking Wollstonecraft and Naremburn through Crows Nest.

Figure 5-12 illustrates both the general intersection layout as modelled in SIDRA Intersection and the layout as per aerial imagery.

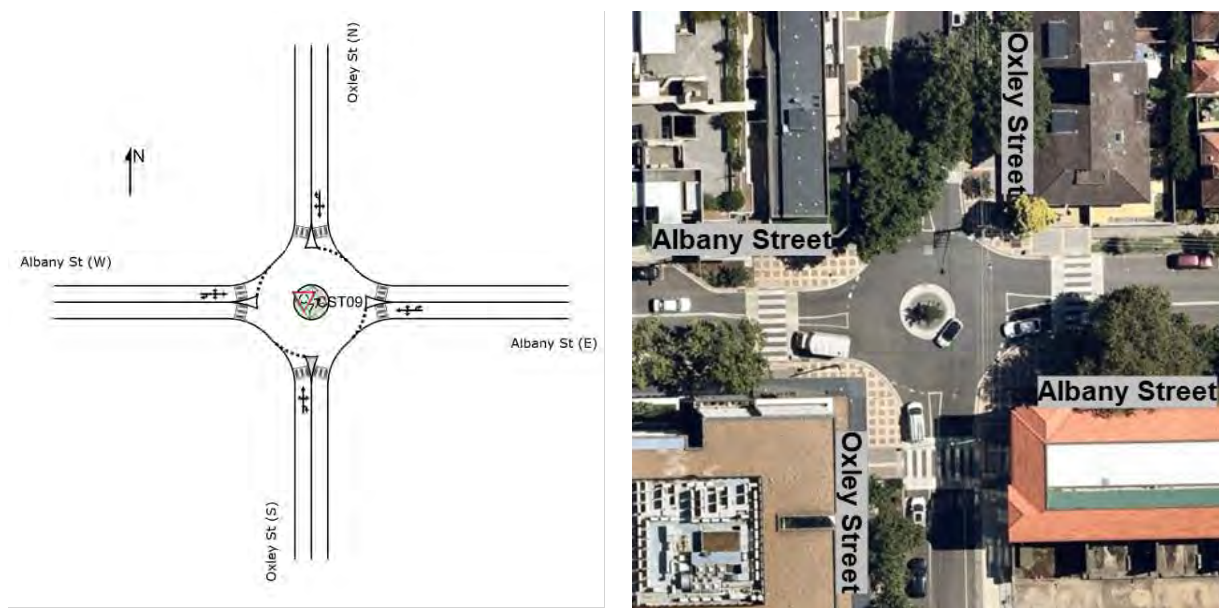

Source: Nearmap, accessed on 24 March 2023

Figure 5-12 Block 1 - SIDRA Intersection layout (left) and Nearmap aerial imagery (right) of CST09

Table 5-14 presents a performance summary of this intersection.

Table 5-14 Block 1 - Intersection performance summary of CST09

| Intersection                              | Peak       | Approach | Degree of saturation | Average delay (seconds) | 95 <sup>th</sup> percentile queue (metres) | Level of service (LOS) |
|---|------------|----------|----------------------|-------------------------|--|------------------------|
| Albany Street / Oxley Street (Roundabout) | Weekday AM | South    | 0.302                | 12.5                    | 14.1                                       | LOS A                  |
|   |            | East     | 0.677                | 14.2                    | 41.1                                       | LOS A                  |
|   |            | North    | 0.460                | 14.2                    | 23.9                                       | LOS A                  |



| Intersection | Peak       | Approach     | Degree of saturation | Average delay (seconds) | 95 <sup>th</sup> percentile queue (metres) | Level of service (LOS) |
|--------------|------------|--------------|----------------------|-------------------------|--|------------------------|
|              |            | West         | 0.618                | 10.7                    | 42.7                                       | LOS A                  |
|              |            | <b>Total</b> | <b>0.677</b>         | <b>14.2</b>             | <b>41.1</b>                                | <b>LOS A</b>           |
|              | Weekday PM | South        | 0.457                | 13.6                    | 23.2                                       | LOS A                  |
|              |            | East         | 0.882                | 20.0                    | 63.3                                       | LOS B                  |
|              |            | North        | 0.429                | 13.8                    | 20.7                                       | LOS A                  |
|              |            | West         | 0.613                | 11.4                    | 44.0                                       | LOS A                  |
|              |            | <b>Total</b> | <b>0.882</b>         | <b>20.0</b>             | <b>63.3</b>                                | <b>LOS B</b>           |
|              | Weekend    | South        | 0.295                | 12.0                    | 13.8                                       | LOS A                  |
|              |            | East         | 0.547                | 11.8                    | 26.1                                       | LOS A                  |
|              |            | North        | 0.353                | 12.3                    | 16.2                                       | LOS A                  |
|              |            | West         | 0.510                | 9.9                     | 32.5                                       | LOS A                  |
|              |            | <b>Total</b> | <b>0.353</b>         | <b>12.3</b>             | <b>16.2</b>                                | <b>LOS A</b>           |

Overall, the intersection of Albany Street and Oxley Street performs satisfactorily at LOS B or better. The 95th percentile queue lengths are accommodated within the approach distances for all approaches.

**5.2.10 CST10 – Albany Street / Clarke Lane**

This priority intersection, composed of Albany Street and Clarke Lane, is located north-west of Crows Nest Station. It connects the local roads of Clarke Lane in Crows Nest with Albany Street, linking Crows Nest and St Leonards.

Figure 5-13 illustrates both the general intersection layout as modelled in SIDRA Intersection and the layout as per aerial imagery.

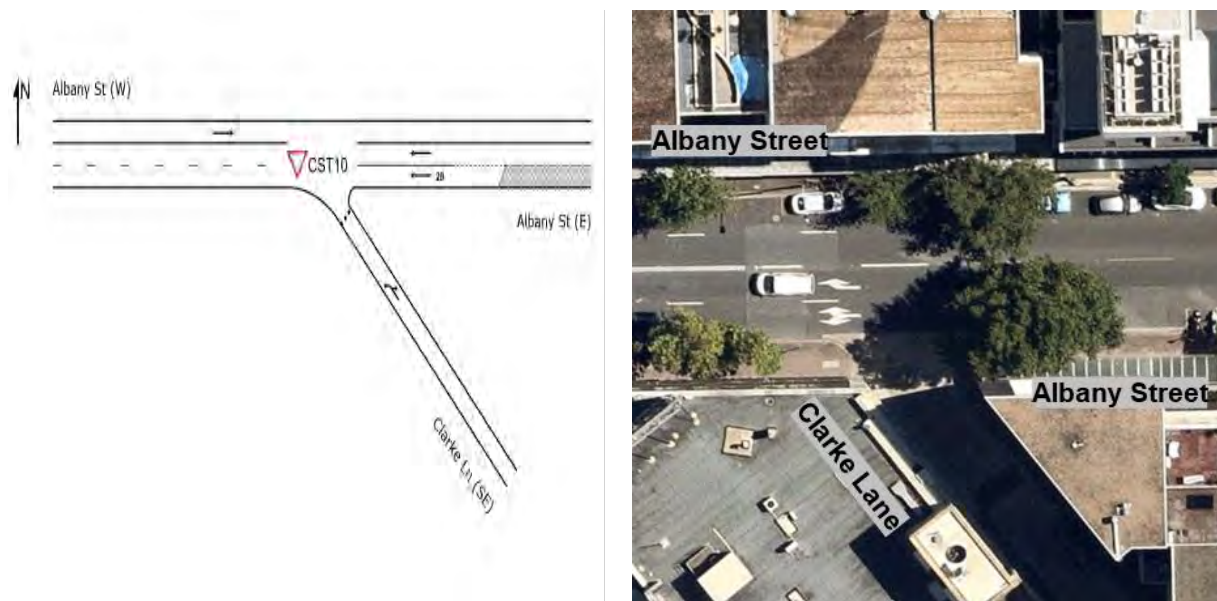

Source: Nearmap, accessed on 24 March 2023

Figure 5-13 Block 1 - SIDRA Intersection layout (left) and Nearmap aerial imagery (right) of CST10

Table 5-15 presents a performance summary of this intersection.

Table 5-15 Block 1 - Intersection performance summary of CST10

| Intersection   | Peak       | Approach     | Degree of saturation | Average delay (seconds) | 95 <sup>th</sup> percentile queue (metres) | Level of service (LOS) |
|--|------------|--------------|----------------------|-------------------------|--|------------------------|
| Albany Street / Clarke Lane<br>(Priority – Give Way) | Weekday AM | South-east   | 0.067                | 31.9                    | 54.0                                       | LOS C                  |
|  |            | East         | 0.242                | 0.0                     | 95.9                                       | LOS A                  |
|  |            | West         | 0.297                | 0.0                     | 0.0  | LOS A                  |
|  |            | <b>Total</b> | <b>0.067</b>         | <b>31.9</b>             | <b>54.0</b>                                | <b>LOS C</b>           |
|  | Weekday PM | South-east   | 0.081                | 15.9                    | 15.8                                       | LOS B                  |
|  |            | East         | 0.143                | 0.0                     | 99.8                                       | LOS A                  |
|  |            | West         | 0.287                | 0.0                     | 0.0  | LOS A                  |
|  |            | <b>Total</b> | <b>0.081</b>         | <b>15.9</b>             | <b>15.8</b>                                | <b>LOS B</b>           |
|  | Weekend    | South-east   | 0.054                | 14.5                    | 45.4                                       | LOS B                  |
|  |            | East         | 0.236                | 0.0                     | 91.6                                       | LOS A                  |
|  |            | West         | 0.272                | 0.0                     | 0.0  | LOS A                  |
|  |            | <b>Total</b> | <b>0.054</b>         | <b>14.5</b>             | <b>45.4</b>                                | <b>LOS B</b>           |

Overall, the intersection of Albany Street and Clarke Lane performs satisfactorily at LOS C or better. The 95<sup>th</sup> percentile queues on Albany Street (east approach) extends back to Oxley Street during all peak hours.

#### 5.2.11 CST11 – Oxley Street / Clarke Lane

This priority intersection, composed of Oxley Street and Clarke Lane, is located directly north-west of Crows Nest Station. It connects the local roads of Clarke Lane in Crows Nest and Oxley Street, linking Wollstonecraft and Naremburn through Crows Nest.

During Block 1, access to Clarke Lane (south-east approach) was limited to Sydney Metro construction vehicles only.

**Figure 5-14** illustrates both the general intersection layout as modelled in SIDRA Intersection and the layout as per aerial imagery.

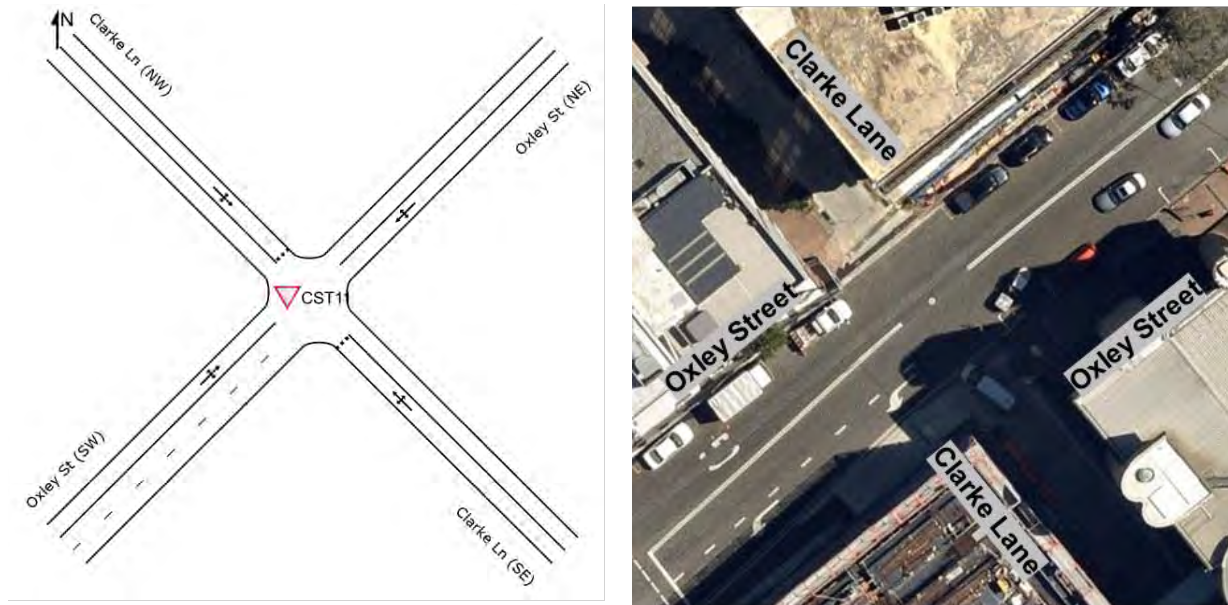

Source: Nearmap, accessed on 24 March 2023

Figure 5-14 Block 1 - SIDRA Intersection layout (left) and Nearmap aerial imagery (right) of CST11

Table 5-16 presents a performance summary of this intersection.

Table 5-16 Block 1 - Intersection performance summary of CST11

| Intersection  | Peak       | Approach     | Degree of saturation | Average delay (seconds) | 95 <sup>th</sup> percentile queue (metres) | Level of service (LOS) |
|---|------------|--------------|----------------------|-------------------------|--|------------------------|
| Oxley Street / Clarke Lane<br>(Priority – Give Way) | Weekday AM | South-east   | 0.008                | 8.3                     | 0.2  | LOS A                  |
|   |            | North-east   | 0.139                | 3.4                     | 24.7                                       | LOS A                  |
|   |            | North-west   | 0.028                | 6.9                     | 1.2  | LOS A                  |
|   |            | South-west   | 0.115                | 4.0                     | 0.2  | LOS A                  |
|   |            | <b>Total</b> | <b>0.008</b>         | <b>8.3</b>              | <b>0.2</b>                                 | <b>LOS A</b>           |
|   | Weekday PM | South-east   | 0.004                | 6.9                     | 0.1  | LOS A                  |
|   |            | North-east   | 0.139                | 5.1                     | 25.5                                       | LOS A                  |
|   |            | North-west   | 0.028                | 6.9                     | 0.8  | LOS A                  |
|   |            | South-west   | 0.120                | 3.3                     | 0.1  | LOS A                  |
|   |            | <b>Total</b> | <b>0.028</b>         | <b>6.9</b>              | <b>0.8</b>                                 | <b>LOS A</b>           |
|   | Weekend    | South-east   | 0.008                | 6.2                     | 0.2  | LOS A                  |
|   |            | North-east   | 0.132                | 3.8                     | 0.4  | LOS A                  |
|   |            | North-west   | 0.021                | 6.2                     | 0.5  | LOS A                  |
|   |            | South-west   | 0.091                | 3.1                     | 0.1  | LOS A                  |
|   |            | <b>Total</b> | <b>0.021</b>         | <b>6.2</b>              | <b>0.5</b>                                 | <b>LOS A</b>           |

Overall, the intersection of Oxley Street and Clarke Lane performs satisfactorily at LOS A. The 95th percentile queue lengths are accommodated within the approach distances for all approaches.

**5.2.12 CST12 – Hume Street / Clarke Lane**

This priority intersection, composed of Hume Street and Clarke Lane, is located within the Crows Nest Station boundary. It connects the local roads of Clarke Lane in Crows Nest and Hume Street, linking Crows Nest and Wollstonecraft.

During Block 1, access to Hume Street (south-west approach) and Clarke Lane (north-west approach) were closed due to Sydney Metro construction. The usage of this intersection was restricted to residential access and the transportation of construction materials.

**Figure 5-15** illustrates both the general intersection layout as modelled in SIDRA Intersection and the layout as per aerial imagery.

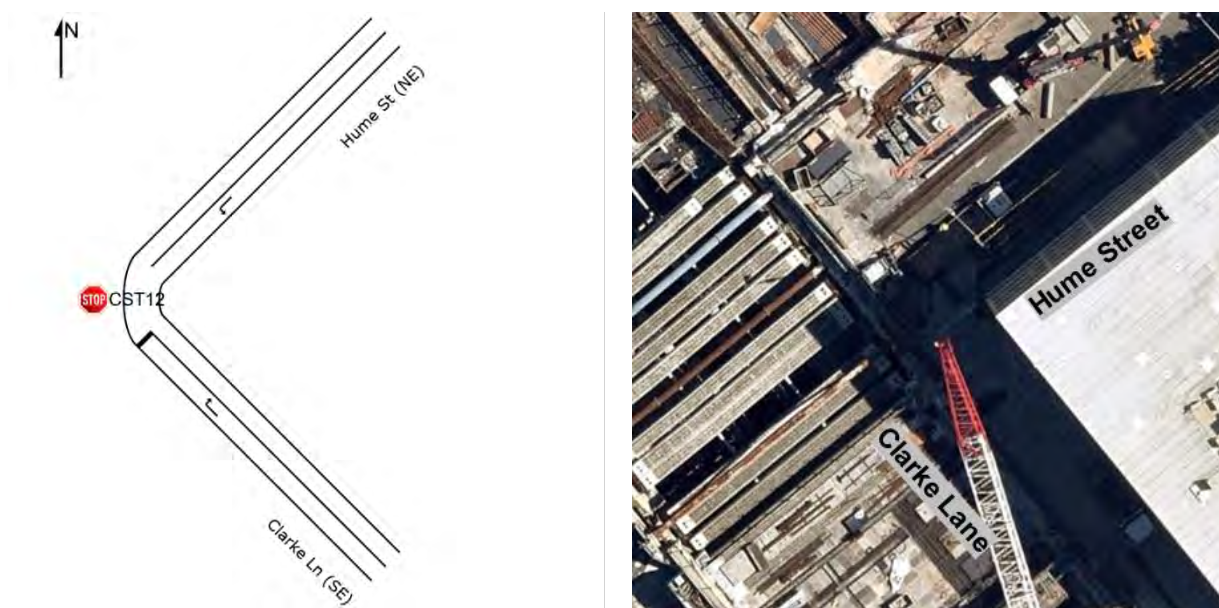

Source: Nearmap, accessed on 24 March 2023

**Figure 5-15 Block 1 - SIDRA Intersection layout (left) and Nearmap aerial imagery (right) of CST12**

**Table 5-17** presents a performance summary of this intersection.

**Table 5-17 Block 1 - Intersection performance summary of CST12**

| Intersection                                   | Peak       | Approach     | Degree of saturation | Average delay (seconds) | 95 <sup>th</sup> percentile queue (metres) | Level of service (LOS) |
|--|------------|--------------|----------------------|-------------------------|--|------------------------|
| Hume Street / Clarke Lane<br>(Priority – Stop) | Weekday AM | South-east   | 0.003                | 6.9                     | 0.0  | LOS A                  |
|  |            | North-east   | 0.011                | 3.2                     | 0.0  | LOS A                  |
|  |            | <b>Total</b> | <b>0.003</b>         | <b>6.9</b>              | <b>0.0</b>                                 | <b>LOS A</b>           |
|  | Weekday PM | South-east   | 0.012                | 6.9                     | 0.0  | LOS A                  |
|  |            | North-east   | 0.001                | 3.2                     | 0.0  | LOS A                  |
|  |            | <b>Total</b> | <b>0.012</b>         | <b>6.9</b>              | <b>0.0</b>                                 | <b>LOS A</b>           |
|  | Weekend    | South-east   | 0.001                | 6.9                     | 0.0  | LOS A                  |
|  |            | North-east   | 0.001                | 3.2                     | 0.0  | LOS A                  |
|  |            | <b>Total</b> | <b>0.001</b>         | <b>6.9</b>              | <b>0.0</b>                                 | <b>LOS A</b>           |



Overall, the intersection of Hume Street and Clarke Lane performs satisfactorily at LOS A. The 95th percentile queue lengths are accommodated within the approach distances for all approaches.

**5.2.13 CST13 – Pacific Highway / Alexander Street**

This signalised intersection, composed of Pacific Highway, Alexander Street and Hayberry Street, is located south-east of Crows Nest Station. It connects the state road of Pacific Highway (A1), linking Wahroonga to North Sydney, with the local roads of Alexander Street and Hayberry Street in Crows Nest. Hayberry Street was not modelled.

**Figure 5-16** illustrates both the general intersection layout as modelled in SIDRA Intersection and the layout as per aerial imagery.

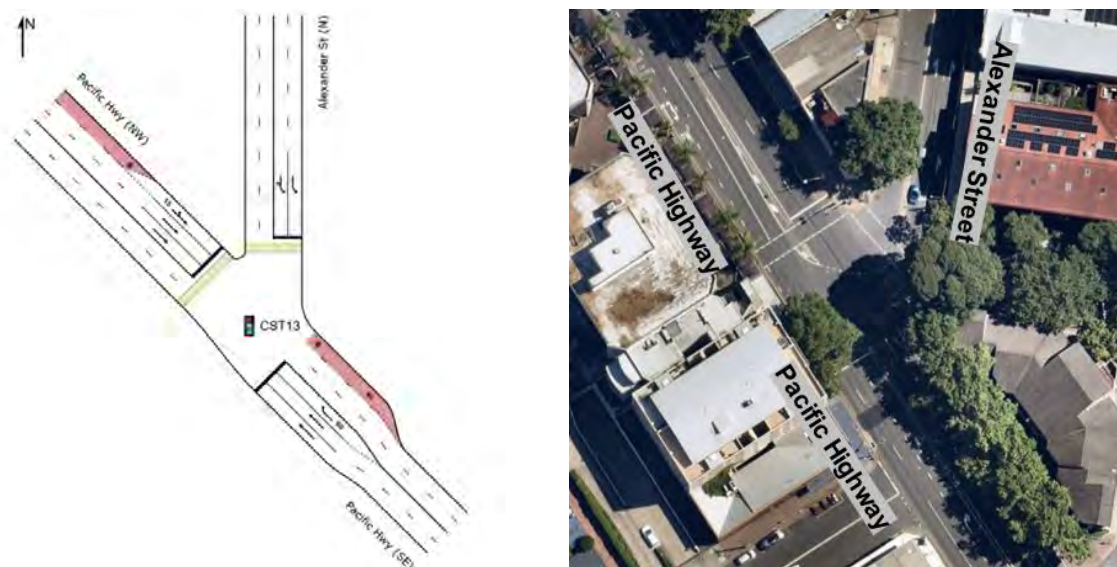

Source: Nearmap, accessed on 24 March 2023

**Figure 5-16** Block 1 - SIDRA Intersection layout (left) and Nearmap aerial imagery (right) of CST13

**Table 5-18** presents a performance summary of this intersection.

**Table 5-18** Block 1 - Intersection performance summary of CST13

| Intersection                                | Peak       | Approach     | Degree of saturation | Average delay (seconds) | 95 <sup>th</sup> percentile queue (metres) | Level of service (LOS) |
|---|------------|--------------|----------------------|-------------------------|--|------------------------|
| Pacific Highway / Alexander Street (Signal) | Weekday AM | South-east   | 0.429                | 10.2                    | 64.0                                       | LOS A                  |
|   |            | North        | 0.874                | 41.8                    | 63.7                                       | LOS C                  |
|   |            | North-west   | 0.765                | 15.7                    | 146.3                                      | LOS B                  |
|   |            | <b>Total</b> | <b>0.874</b>         | <b>16.9</b>             | <b>146.3</b>                               | <b>LOS B</b>           |
|   | Weekday PM | South-east   | 0.539                | 15.1                    | 85.6                                       | LOS B                  |
|   |            | North        | 0.528                | 43.8                    | 68.1                                       | LOS D                  |
|   |            | North-west   | 0.514                | 19.0                    | 79.9                                       | LOS B                  |
|   |            | <b>Total</b> | <b>0.539</b>         | <b>20.8</b>             | <b>85.6</b>                                | <b>LOS B</b>           |
|   | Weekend    | South-east   | 0.419                | 11.2                    | 62.4                                       | LOS A                  |
|   |            | North        | 0.421                | 43.3                    | 49.5                                       | LOS D                  |
|   |            | North-west   | 0.341                | 10.8                    | 42.6                                       | LOS A                  |
|   |            | <b>Total</b> | <b>0.421</b>         | <b>15.9</b>             | <b>62.4</b>                                | <b>LOS B</b>           |

Overall, the intersection of the Pacific Highway (A1) and Alexander Street performs satisfactorily at LOS B. The 95th percentile queue on the Pacific Highway (A1) (north-west approach) extends back to Shirley Road and Falcon Street during the weekday AM peak hour.

**5.2.14 CST14 – Falcon Street / Alexander Street**

This signalised intersection, comprised of Falcon Street and Alexander Street, is located south-east of Crows Nest Station. It connects the local road of Alexander Street in Crows Nest with the state road of Falcon Street, linking Crows Nest and Neutral Bay.

**Figure 5-17** illustrates both the general intersection layout as modelled in SIDRA Intersection and the layout as per aerial imagery.

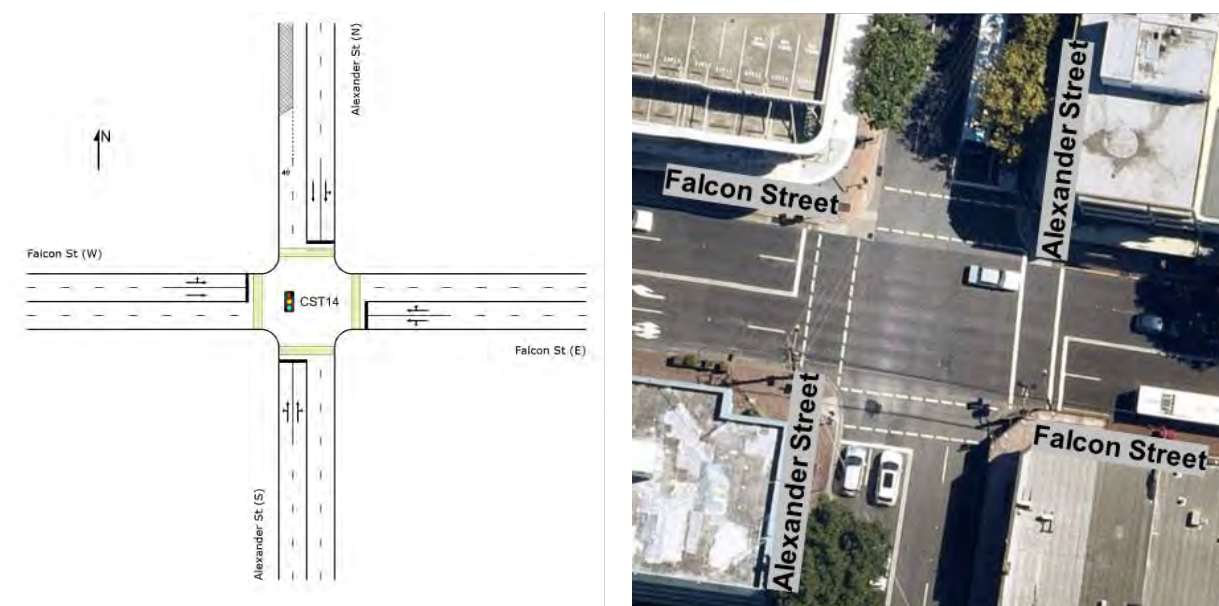

Source: Nearmap, accessed on 24 March 2023

**Figure 5-17 Block 1 - SIDRA Intersection layout (left) and Nearmap aerial imagery (right) of CST14**

**Table 5-19** presents a performance summary of this intersection.

**Table 5-19 Block 1 - Intersection performance summary of CST14**

| Intersection                              | Peak       | Approach     | Degree of saturation | Average delay (seconds) | 95 <sup>th</sup> percentile queue (metres) | Level of service (LOS) |
|---|------------|--------------|----------------------|-------------------------|--|------------------------|
| Falcon Street / Alexander Street (Signal) | Weekday AM | South        | 0.927                | 72.3                    | 117.8                                      | LOS F                  |
|   |            | East         | 0.283                | 1.1                     | 99.1                                       | LOS A                  |
|   |            | North        | 0.720                | 61.3                    | 98.7                                       | LOS E                  |
|   |            | West         | 0.319                | 1.5                     | 7.6  | LOS A                  |
|   |            | <b>Total</b> | <b>0.927</b>         | <b>21.0</b>             | <b>117.8</b>                               | <b>LOS B</b>           |
|   | Weekday PM | South        | 0.525                | 38.5                    | 57.0                                       | LOS C                  |
|   |            | East         | 0.536                | 19.0                    | 118.1                                      | LOS B                  |
|   |            | North        | 0.530                | 48.4                    | 84.9                                       | LOS D                  |
|   |            | West         | 0.273                | 1.3                     | 5.2  | LOS A                  |
|   |            | <b>Total</b> | <b>0.536</b>         | <b>19.8</b>             | <b>118.1</b>                               | <b>LOS B</b>           |
| Weekend                                   | South      | 0.825        | 61.3                 | 76.0                    | LOS E                                      |                        |

| Intersection | Peak | Approach     | Degree of saturation | Average delay (seconds) | 95 <sup>th</sup> percentile queue (metres) | Level of service (LOS) |
|--------------|------|--------------|----------------------|-------------------------|--|------------------------|
|              |      | East         | 0.633                | 1.9                     | 39.6                                       | LOS A                  |
|              |      | North        | 0.914                | 103.2                   | 143.8                                      | LOS F                  |
|              |      | West         | 0.894                | 9.8                     | 79.2                                       | LOS A                  |
|              |      | <b>Total</b> | <b>0.914</b>         | <b>24.6</b>             | <b>143.8</b>                               | <b>LOS B</b>           |

Overall, the intersection of Falcon Street and Alexander Street performs satisfactorily at LOS B. The 95<sup>th</sup> percentile queues on Alexander Street (north approach) extend back to Burlington Street during the weekday AM peak and weekend peak hours.

### 5.3 Victoria Cross Station

Victoria Cross Station is a new underground station and the third stop on the City & Southwest Line (towards Sydenham). It is located in the centre of the North Sydney commercial centre and north of the existing North Sydney Station.

Victoria Cross Station will have two station entrances, Victoria Cross North, at the north-east corner of the intersection of Miller Street and McLaren Street, and Victoria Cross South, at the south-east corner of the intersection of Miller Street and Berry Street. Victoria Cross Station was still under construction during Block 1. Construction access to Victoria Cross North was facilitated via McLaren Street, east of Miller Street, whereas access to Victoria Cross South was facilitated via Denison Street.

Bus services are available within approximately 150 metres of Victoria Cross Station, located along Miller Street and Pacific Highway. Pedestrian footpaths are provided on both sides of Miller Street and Pacific Highway in the vicinity of Victoria Cross Station.

The Victoria Cross Station study area consists of four intersections. **Table 5-20** presents the peak hours utilised for modelling the intersections. **Table 5-21** provides a summary of the intersection level of service while

Figure 5-18 visualises a geospatial summary of the intersection level of service within the Victoria Cross Station study area.

**Table 5-20 Block 1 - Victoria Cross Station peak hours modelled**

| Network ID | Intersection ID | Weekday AM peak hour |            | Weekday PM peak hour |            | Weekend peak hour |            |
|------------|-----------------|----------------------|------------|----------------------|------------|-------------------|------------|
|            |                 | Day                  | Start time | Day                  | Start time | Day               | Start time |
| VIC-N1     | VIC01           | Monday               | 8.45am     | Wednesday            | 3.00pm     | Saturday          | 11.30am    |
|            | VIC02           |                      |            |                      |            |                   |            |
|            | VIC03           |                      |            |                      |            |                   |            |
|            | VIC04           |                      |            |                      |            |                   |            |

**Table 5-21 Block 1 - Victoria Cross Station intersection performance summary**

| Intersection ID | Intersection                            | Level of service (LOS) |                 |              |
|-----------------|---|------------------------|-----------------|--------------|
|                 |   | Weekday AM Peak        | Weekday PM Peak | Weekend Peak |
| VIC01           | Pacific Highway / Berry Street (Signal) | LOS A                  | LOS A           | LOS A        |
| VIC02           | Miller Street / Berry Street (Signal)   | LOS C                  | LOS C           | LOS B        |

| Intersection ID | Intersection                             | Level of service (LOS) |                 |              |
|-----------------|--|------------------------|-----------------|--------------|
|                 |  | Weekday AM Peak        | Weekday PM Peak | Weekend Peak |
| VIC03           | Miller Street / McLaren Street (Signal)  | LOS B                  | LOS B           | LOS B        |
| VIC04           | Pacific Highway / Miller Street (Signal) | LOS B                  | LOS B           | LOS B        |

Overall, in the Victoria Cross Station study area, the intersection performance during the peak periods is satisfactory, operating at LOS C or better.



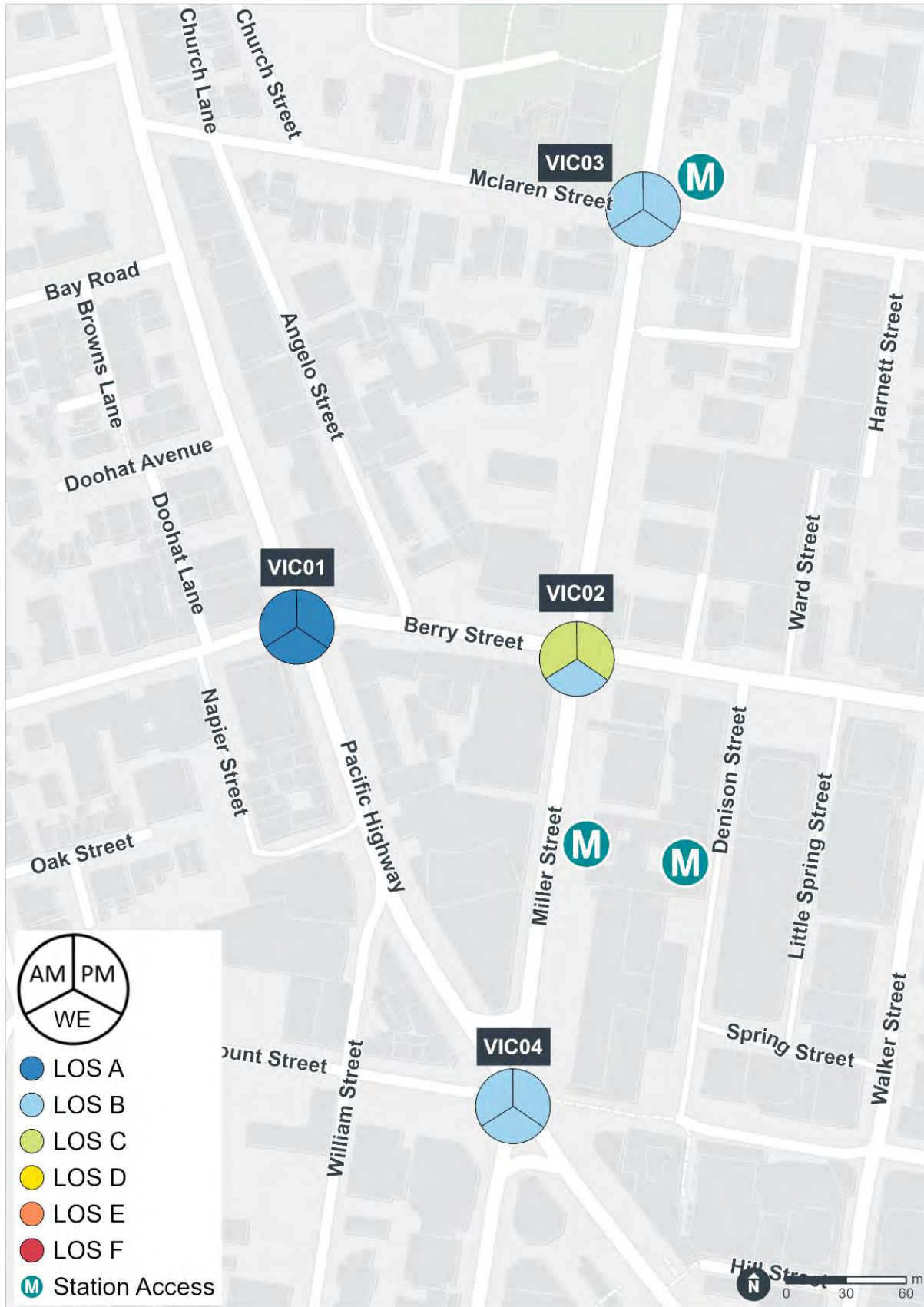
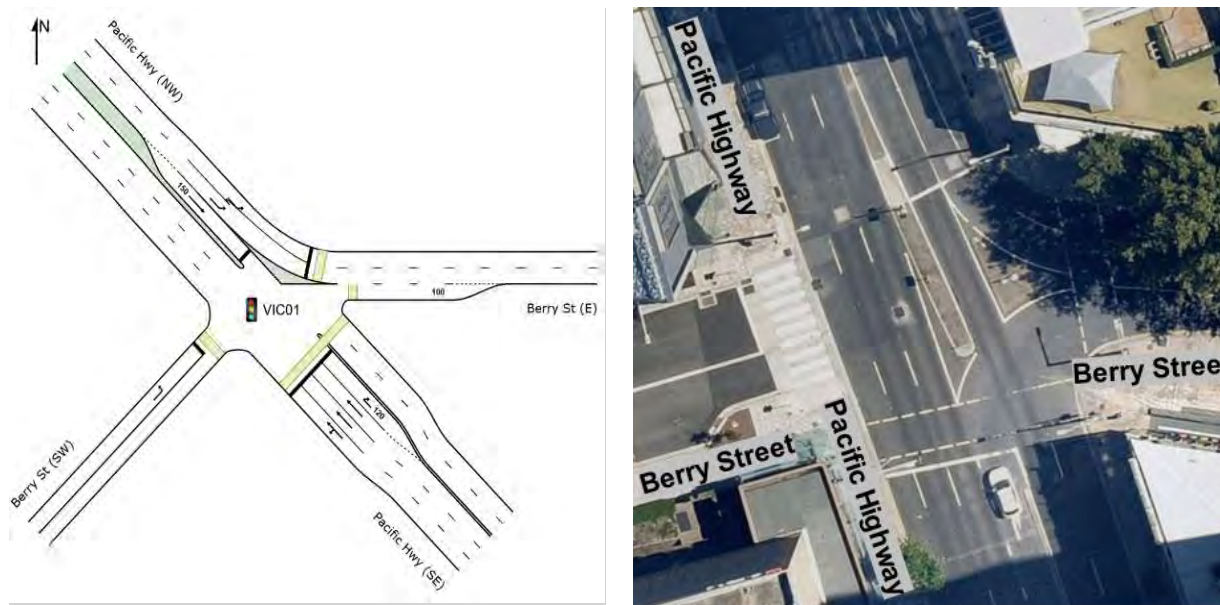

Figure 5-18 Block 1 – Victoria Cross Station geospatial intersection performance summary

### 5.3.1 VIC01 – Pacific Highway / Berry Street

This signalised intersection, composed of Pacific Highway and Berry Street, is located east of Victoria Cross South. It connects the state road of Pacific Highway (A1), linking Wahroonga and North Sydney, with the local road of Berry Street, linking North Sydney to the Warringah Freeway (M1). Berry Street (south-west approach) is not signalised; however, for modelling purposes, it has been simulated as a signalised approach operating in every phase.

**Figure 5-19** illustrates both the general intersection layout as modelled in SIDRA Intersection and the layout as per aerial imagery.



Source: Nearmap, accessed on 24 March 2023

**Figure 5-19 Block 1 - SIDRA Intersection layout (left) and Nearmap aerial imagery (right) of VIC01**

**Table 5-22** presents a performance summary of this intersection.

**Table 5-22 Block 1 - Intersection performance summary of VIC01**

| Intersection                            | Peak       | Approach     | Degree of saturation | Average delay (seconds) | 95 <sup>th</sup> percentile queue (metres) | Level of service (LOS) |
|---|------------|--------------|----------------------|-------------------------|--|------------------------|
| Pacific Highway / Berry Street (Signal) | Weekday AM | South-east   | 0.663                | 8.1                     | 28.8                                       | LOS A                  |
|   |            | North-west   | 0.519                | 11.9                    | 86.9                                       | LOS A                  |
|   |            | South-west   | 0.066                | 4.4                     | 1.9  | LOS A                  |
|   |            | <b>Total</b> | <b>0.663</b>         | <b>9.9</b>              | <b>86.9</b>                                | <b>LOS A</b>           |
|   | Weekday PM | South-east   | 0.859                | 13.6                    | 66.8                                       | LOS A                  |
|   |            | North-west   | 0.414                | 11.0                    | 63.3                                       | LOS A                  |
|   |            | South-west   | 0.056                | 4.5                     | 1.6  | LOS A                  |
|   |            | <b>Total</b> | <b>0.859</b>         | <b>12.3</b>             | <b>66.8</b>                                | <b>LOS A</b>           |
|   | Weekend    | South-east   | 0.491                | 7.3                     | 33.5                                       | LOS A                  |
|   |            | North-west   | 0.295                | 7.9                     | 51.5                                       | LOS A                  |
|   |            | South-west   | 0.032                | 4.9                     | 1.1  | LOS A                  |
|   |            | <b>Total</b> | <b>0.491</b>         | <b>7.6</b>              | <b>51.5</b>                                | <b>LOS A</b>           |

Overall, the intersection of the Pacific Highway (A1) and Berry Street performs satisfactorily at LOS A. The 95th percentile queue lengths are accommodated within the approach distances for all approaches.

### 5.3.2 VIC02 – Miller Street / Berry Street

This signalised intersection, composed of Miller Street and Berry Street, is located directly west of Victoria Cross South. It connects the regional road of Miller Street, linking Cammeray and North Sydney, with the local road of Berry Street, linking North Sydney to the Warringah Freeway (M1).

During Block 1, the southern departure kerbside lane of Miller Street was closed off due to Sydney Metro construction.

Figure 5-20 illustrates both the general intersection layout as modelled in SIDRA Intersection and the layout as per aerial imagery.

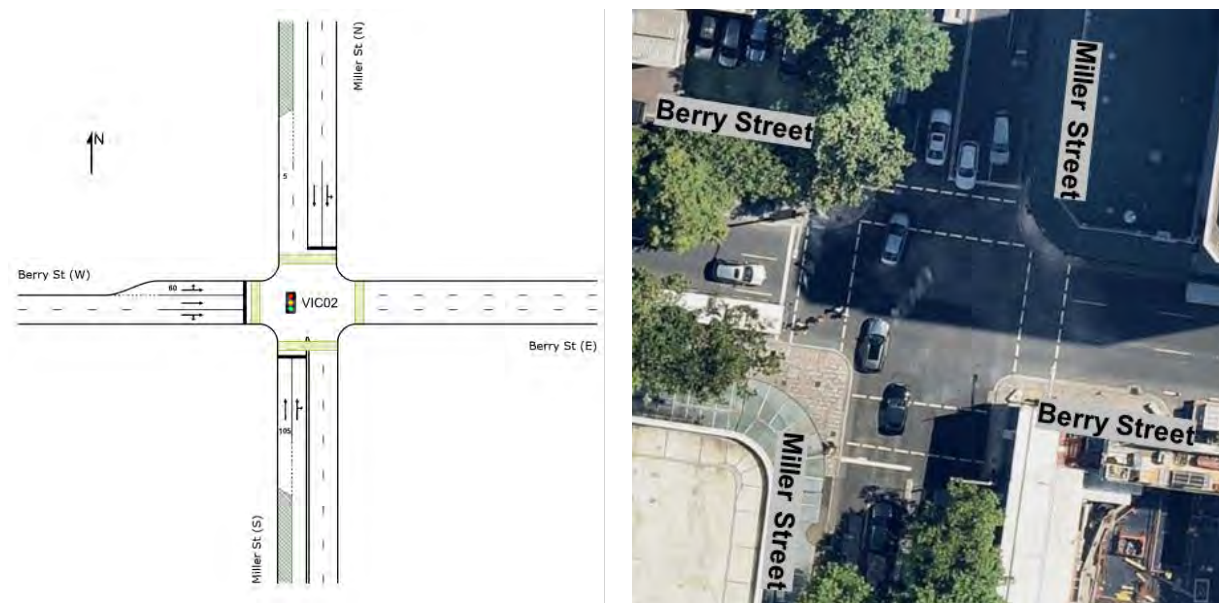

Source: Nearmap, accessed on 24 March 2023

Figure 5-20 Block 1 - SIDRA Intersection layout (left) and Nearmap aerial imagery (right) of VIC02

Table 5-23 presents a performance summary of this intersection.

Table 5-23 Block 1 - Intersection performance summary of VIC02

| Intersection                          | Peak       | Approach     | Degree of saturation | Average delay (seconds) | 95 <sup>th</sup> percentile queue (metres) | Level of service (LOS) |
|---------------------------------------|------------|--------------|----------------------|-------------------------|--|------------------------|
| Miller Street / Berry Street (Signal) | Weekday AM | South        | 0.851                | 35.5                    | 81.7                                       | LOS C                  |
|                                       |            | North        | 0.778                | 40.6                    | 90.8                                       | LOS C                  |
|                                       |            | West         | 0.439                | 24.1                    | 66.2                                       | LOS B                  |
|                                       |            | <b>Total</b> | <b>0.851</b>         | <b>32.0</b>             | <b>90.8</b>                                | <b>LOS C</b>           |
|                                       | Weekday PM | South        | 0.701                | 27.5                    | 74.7                                       | LOS B                  |
|                                       |            | North        | 0.619                | 37.8                    | 69.8                                       | LOS C                  |
|                                       |            | West         | 0.537                | 31.5                    | 99.5                                       | LOS C                  |
|                                       |            | <b>Total</b> | <b>0.701</b>         | <b>31.8</b>             | <b>99.5</b>                                | <b>LOS C</b>           |
|                                       | Weekend    | South        | 0.748                | 23.3                    | 55.0                                       | LOS B                  |
|                                       |            | North        | 0.720                | 41.0                    | 50.5                                       | LOS C                  |



| Intersection | Peak | Approach     | Degree of saturation | Average delay (seconds) | 95 <sup>th</sup> percentile queue (metres) | Level of service (LOS) |
|--------------|------|--------------|----------------------|-------------------------|--|------------------------|
|              |      | West         | 0.369                | 22.7                    | 72.2                                       | LOS B                  |
|              |      | <b>Total</b> | <b>0.748</b>         | <b>27.1</b>             | <b>72.2</b>                                | <b>LOS B</b>           |

Overall, the intersection of Miller Street and Berry Street performs satisfactorily at LOS C or better. The 95th percentile queue lengths are accommodated within the approach distances for all approaches.

**5.3.3 VIC03 – Miller Street / McLaren Street**

This signalised intersection, composed of Miller Street and McLaren Street, is located directly south of Victoria Cross North. It connects the regional road of Miller Street, linking North Sydney and Cammeray, with the local road of McLaren Street in North Sydney.

Figure 5-21 illustrates both the general intersection layout as modelled in SIDRA Intersection and the layout as per aerial imagery.

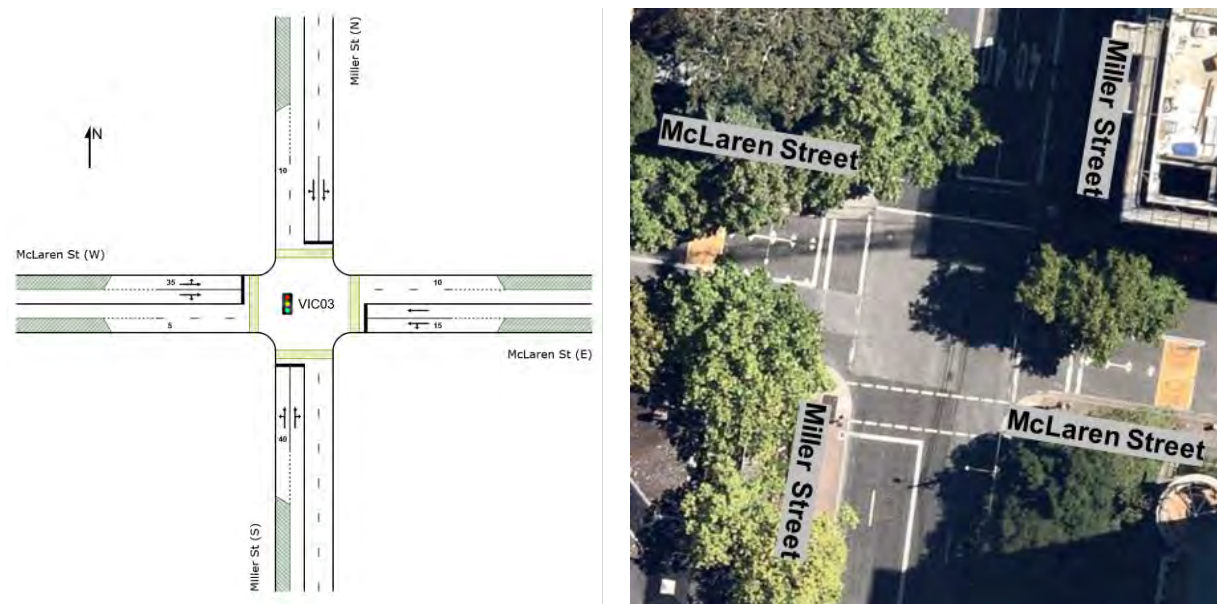

Source: Nearmap, accessed on 24 March 2023

Figure 5-21 Block 1 - SIDRA Intersection layout (left) and Nearmap aerial imagery (right) of VIC03

Table 5-24 presents a performance summary of this intersection.

Table 5-24 Block 1 - Intersection performance summary of VIC03

| Intersection                               | Peak       | Approach     | Degree of saturation | Average delay (seconds) | 95 <sup>th</sup> percentile queue (metres) | Level of service (LOS) |
|--|------------|--------------|----------------------|-------------------------|--|------------------------|
| Miller Street / McLaren Street<br>(Signal) | Weekday AM | South        | 0.298                | 12.1                    | 34.3                                       | LOS A                  |
|  |            | East         | 0.759                | 31.0                    | 21.7                                       | LOS C                  |
|  |            | North        | 0.333                | 15.0                    | 41.5                                       | LOS B                  |
|  |            | West         | 0.393                | 24.5                    | 22.8                                       | LOS B                  |
|  |            | <b>Total</b> | <b>0.759</b>         | <b>18.2</b>             | <b>41.5</b>                                | <b>LOS B</b>           |
|  |            | South        | 0.205                | 9.8                     | 27.3                                       | LOS A                  |



| Intersection | Peak       | Approach     | Degree of saturation | Average delay (seconds) | 95 <sup>th</sup> percentile queue (metres) | Level of service (LOS) |
|--------------|------------|--------------|----------------------|-------------------------|--|------------------------|
|              | Weekday PM | East         | 0.747                | 37.5                    | 20.7                                       | LOS C                  |
|              |            | North        | 0.339                | 13.3                    | 43.4                                       | LOS A                  |
|              |            | West         | 0.403                | 31.4                    | 26.0                                       | LOS C                  |
|              |            | <b>Total</b> | <b>0.747</b>         | <b>18.1</b>             | <b>43.4</b>                                | <b>LOS B</b>           |
|              | Weekend    | South        | 0.292                | 8.2                     | 37.3                                       | LOS A                  |
|              |            | East         | 0.262                | 31.7                    | 17.3                                       | LOS C                  |
|              |            | North        | 0.316                | 10.9                    | 38.4                                       | LOS A                  |
|              |            | West         | 0.219                | 27.3                    | 15.2                                       | LOS B                  |
|              |            | <b>Total</b> | <b>0.316</b>         | <b>14.7</b>             | <b>38.4</b>                                | <b>LOS B</b>           |

Overall, the intersection of Miller Street and McLaren Street performs satisfactorily at LOS B. The 95th percentile queue lengths are accommodated within the approach distances for all approaches.

**5.3.4 VIC04 – Pacific Highway / Miller Street**

This signalised intersection, composed of the Pacific Highway, Miller Street and Mount Street, is located directly south of Victoria Cross South. It connects the state road of Pacific Highway (A1), linking Wahroonga and North Sydney, with the regional road of Miller Street, linking North Sydney and Cammeray. Additionally, it provides travel to the west of North Sydney via the Mount Street unsignalised egress-only approach.

Figure 5-22 illustrates both the general intersection layout as modelled in SIDRA Intersection and the layout as per aerial imagery.

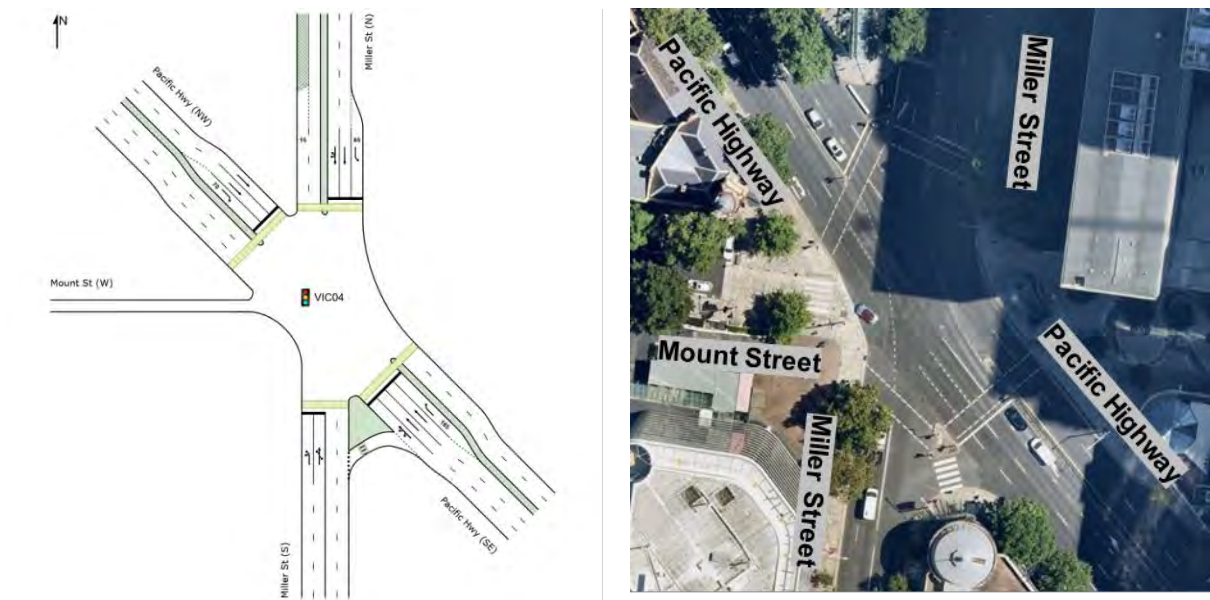

Source: Nearthmap, accessed on 24 March 2023

Figure 5-22 Block 1 - SIDRA Intersection layout (left) and Nearthmap aerial imagery (right) of VIC04

Table 5-25 presents a performance summary of this intersection.

Table 5-25 Block 1 - Intersection performance summary of VIC04

| Intersection                             | Peak       | Approach     | Degree of saturation | Average delay (seconds) | 95 <sup>th</sup> percentile queue (metres) | Level of service (LOS) |
|--|------------|--------------|----------------------|-------------------------|--|------------------------|
| Pacific Highway / Miller Street (Signal) | Weekday AM | South        | 0.644                | 33.3                    | 75.6                                       | LOS C                  |
|  |            | South-east   | 0.747                | 28.6                    | 92.3                                       | LOS C                  |
|  |            | North        | 0.313                | 11.4                    | 17.5                                       | LOS A                  |
|  |            | North-west   | 0.446                | 25.7                    | 35.9                                       | LOS B                  |
|  |            | <b>Total</b> | <b>0.747</b>         | <b>26.5</b>             | <b>92.3</b>                                | <b>LOS B</b>           |
|  | Weekday PM | South        | 0.682                | 35.4                    | 75.8                                       | LOS C                  |
|  |            | South-east   | 0.809                | 27.2                    | 115.3                                      | LOS B                  |
|  |            | North        | 0.274                | 12.5                    | 15.3                                       | LOS A                  |
|  |            | North-west   | 0.328                | 28.3                    | 42.7                                       | LOS B                  |
|  |            | <b>Total</b> | <b>0.809</b>         | <b>26.8</b>             | <b>115.3</b>                               | <b>LOS B</b>           |
|  | Weekend    | South        | 0.607                | 29.8                    | 66.8                                       | LOS C                  |
|  |            | South-east   | 0.554                | 26.0                    | 76.5                                       | LOS B                  |
|  |            | North        | 0.361                | 8.8                     | 10.3                                       | LOS A                  |
|  |            | North-west   | 0.455                | 30.2                    | 50.7                                       | LOS C                  |
|  |            | <b>Total</b> | <b>0.607</b>         | <b>25.5</b>             | <b>76.5</b>                                | <b>LOS B</b>           |

Overall, the intersection of the Pacific Highway (A1), Miller Street and Mount Street performs satisfactorily at LOS B. The 95th percentile queue lengths are accommodated within the approach distances for all approaches.

## 5.4 Barangaroo Station

Barangaroo Station is a new underground station and the fourth stop on the City & Southwest Line (towards Sydenham). It is located at the northern area of Barangaroo, south of Munn Street, bounded by Hickson Road.

Barangaroo Station was still under construction during Block 1. Construction access and egress to the station was facilitated through the newly constructed Barangaroo Avenue via Hickson Road.

Bus services are available within approximately 400 metres of Barangaroo Station, located along Hickson Road and Kent Street. Dedicated cycle lanes are provided along the Sydney Harbour Bridge on-ramp and Kent Street, south of the intersection of Kent Street, Clarence Street and the Sydney Harbour Bridge on-ramp. Around the station precinct, there will be two new bus stops on Hickson Road (one northbound travel and one southbound travel). Kiss and ride bays and taxi zones will be provided at the proposed Hickson Road interchange, and coach bays underneath Munn Street bridge.

The Barangaroo Station study area consists of 18 intersections. During Block 1, two intersections were new pedestrian mid-block crossings which have not yet been constructed. **Table 5-26** presents the peak hours utilised for modelling the intersections. **Table 5-27** provides a summary of the intersection level of service while

Figure 5-23 visualises a geospatial summary of the intersection level of service within the Barangaroo Station study area.

**Table 5-26 Block 1 - Barangaroo Station peak hours modelled**

| Network ID | Intersection ID | Weekday AM peak hour |            | Weekday PM peak hour |            | Weekend peak hour |            |
|------------|-----------------|----------------------|------------|----------------------|------------|-------------------|------------|
|            |                 | Day                  | Start time | Day                  | Start time | Day               | Start time |
| BGU-N1     | BGU01           | Tuesday              | 8.45am     | Wednesday            | 5.15pm     | Saturday          | 1.15pm     |
|            | BGU02           |                      |            |                      |            |                   |            |
| BGU-N2     | BGU04           | Tuesday              | 8.30am     | Thursday             | 5.30pm     | Saturday          | 12.15pm    |
|            | BGU05           |                      |            |                      |            |                   |            |
|            | BGU07           |                      |            |                      |            |                   |            |
|            | BGU08           |                      |            |                      |            |                   |            |
|            | BGU09           |                      |            |                      |            |                   |            |
| BGU-N3     | BGU06           | Tuesday              | 8.30am     | Thursday             | 5.30pm     | Saturday          | 12.15pm    |
|            | BGU10           |                      |            |                      |            |                   |            |
|            | BGU11           |                      |            |                      |            |                   |            |
|            | BGU12           |                      |            |                      |            |                   |            |
|            | BGU13           |                      |            |                      |            |                   |            |
|            | BGU18           |                      |            |                      |            |                   |            |
| BGU-N4     | BGU14           | Tuesday              | 8.30am     | Thursday             | 5.30pm     | Saturday          | 12.15pm    |
|            | BGU15           |                      |            |                      |            |                   |            |
| -          | BGU03           | Tuesday              | 8.45am     | Thursday             | 6.00pm     | Saturday          | 12.00pm    |
| -          | BGU16           | Under construction.  |            |                      |            |                   |            |
| -          | BGU17           | Under construction.  |            |                      |            |                   |            |

Table 5-27 Block 1 - Barangaroo Station intersection performance summary

| Intersection ID | Intersection   | Level of service (LOS) |                 |              |
|-----------------|--|------------------------|-----------------|--------------|
|                 |  | Weekday AM Peak        | Weekday PM Peak | Weekend Peak |
| BGU01           | Hickson Road / Towns Place<br>(Priority – Give Way)  | LOS A                  | LOS A           | LOS A        |
| BGU02           | Dalgety Road / Towns Place<br>(Roundabout)   | LOS A                  | LOS A           | LOS A        |
| BGU03           | Kent Street / Argyle Street<br>(Priority – Give Way)   | LOS A                  | LOS A           | LOS A        |
| BGU04           | Pedestrian Mid-block Crossing at<br>Kent Street near Gas Lane<br>(Pedestrian only - Signal)          | LOS B                  | LOS B           | LOS B        |
| BGU05           | Kent Street / Sydney Harbour Bridge<br>(SHB) On-ramp<br>(Signal)                                     | LOS B                  | LOS B           | LOS B        |
| BGU06           | Hickson Road / Napoleon Street /<br>Sussex Street<br>(Signal)  | LOS B                  | LOS B           | LOS B        |
| BGU07           | Margaret Street / Kent Street /<br>Napoleon Street<br>(Signal)                                       | LOS B                  | LOS B           | LOS B        |
| BGU08           | Margaret Street / Clarence Street<br>(Signal)  | LOS B                  | LOS B           | LOS B        |
| BGU09           | Margaret Street / York Street<br>(Signal)  | LOS B                  | LOS B           | LOS B        |
| BGU10           | Pedestrian Mid-block Crossing at<br>Sussex Street under Exchange Place<br>(Pedestrian only - Signal) | LOS A                  | LOS A           | LOS A        |
| BGU11           | Pedestrian Mid-block Crossing at Kent<br>Street near Margaret Street<br>(Pedestrian only - Signal)   | LOS A                  | LOS A           | LOS A        |
| BGU12           | Sussex Street / Erskine Street<br>(Signal)   | LOS B                  | LOS B           | LOS B        |



| Intersection ID | Intersection   | Level of service (LOS) |                 |              |
|-----------------|--|------------------------|-----------------|--------------|
|                 |  | Weekday AM Peak        | Weekday PM Peak | Weekend Peak |
| BGU13           | Kent Street / Erskine Street (Signal)  | LOS B                  | LOS B           | LOS C        |
| BGU14           | Sussex Street / King Street (Signal)   | LOS B                  | LOS B           | LOS B        |
| BGU15           | Kent Street / King Street (Signal)   | LOS B                  | LOS B           | LOS B        |
| BGU16           | New Pedestrian Mid-block Crossing at New Hickson Road (north of Metro Station)<br>(Pedestrian only - Signal) | Under construction.    |                 |              |
| BGU17           | New Pedestrian Mid-block Crossing at New Hickson Road (south of Metro Station)<br>(Pedestrian only - Signal) | Under construction.    |                 |              |
| BGU18           | Shelley Street / Erskine Street (Signal)   | LOS B                  | LOS B           | LOS B        |

Overall, in the Barangaroo Station study area, the intersection performance during the peak periods is satisfactory, operating at LOS C or better.



Figure 5-23 Block 1 – Barangaroo Station geospatial intersection performance summary

**5.4.1 BGU01 – Hickson Road / Towns Place**

The priority intersection, composed of Hickson Road and Towns Place, is located north of Barangaroo Station. It connects the local road of Towns Place with the regional road of Hickson Road which runs along the western waterfront of Barangaroo.

**Figure 5-24** illustrates both the general intersection layout as modelled in SIDRA Intersection and the layout as per aerial imagery.



Source: Nearmap, accessed on 24 March 2023

**Figure 5-24 Block 1 – SIDRA Intersection layout (left) and Nearmap aerial imagery (right) of BGU01**

**Table 5-28** presents a performance summary of this intersection.

**Table 5-28 Block 1 – Intersection performance summary of BGU01**

| Intersection  | Peak       | Approach     | Degree of saturation | Average delay (seconds) | 95 <sup>th</sup> percentile queue (metres) | Level of service (LOS) |
|---|------------|--------------|----------------------|-------------------------|--|------------------------|
| Hickson Road / Towns Place<br>(Priority – Give Way) | Weekday AM | East         | 0.148                | 5.8                     | 5.0  | LOS A                  |
|   |            | North-west   | 0.269                | 9.1                     | 8.3  | LOS A                  |
|   |            | South-west   | 0.281                | 4.5                     | 11.3                                       | LOS A                  |
|   |            | <b>Total</b> | <b>0.269</b>         | <b>9.1</b>              | <b>8.3</b>                                 | <b>LOS A</b>           |
|   | Weekday PM | East         | 0.188                | 6.0                     | 6.1  | LOS A                  |
|   |            | North-west   | 0.279                | 8.2                     | 8.4  | LOS A                  |
|   |            | South-west   | 0.278                | 4.1                     | 10.9                                       | LOS A                  |
|   |            | <b>Total</b> | <b>0.279</b>         | <b>8.2</b>              | <b>8.4</b>                                 | <b>LOS A</b>           |
|   | Weekend    | East         | 0.153                | 4.2                     | 5.1  | LOS A                  |
|   |            | North-west   | 0.159                | 6.1                     | 4.6  | LOS A                  |
|   |            | South-west   | 0.159                | 3.8                     | 5.7  | LOS A                  |
|   |            | <b>Total</b> | <b>0.159</b>         | <b>6.1</b>              | <b>4.6</b>                                 | <b>LOS A</b>           |



Overall, the intersection of Hickson Road and Towns Place performs satisfactorily at LOS A. The 95<sup>th</sup> percentile queue lengths are accommodated within the approach distances for all approaches.

**5.4.2 BGU02 – Dalgety Road / Towns Place**

The roundabout intersection, composed of Dalgety Road and Towns Place, is located north of Barangaroo Station. It connects the local roads of Dalgety Road and Towns Place in Barangaroo with the Barangaroo Reserve car park.

**Figure 5-25** illustrates both the general intersection layout as modelled in SIDRA Intersection and the layout as per aerial imagery.

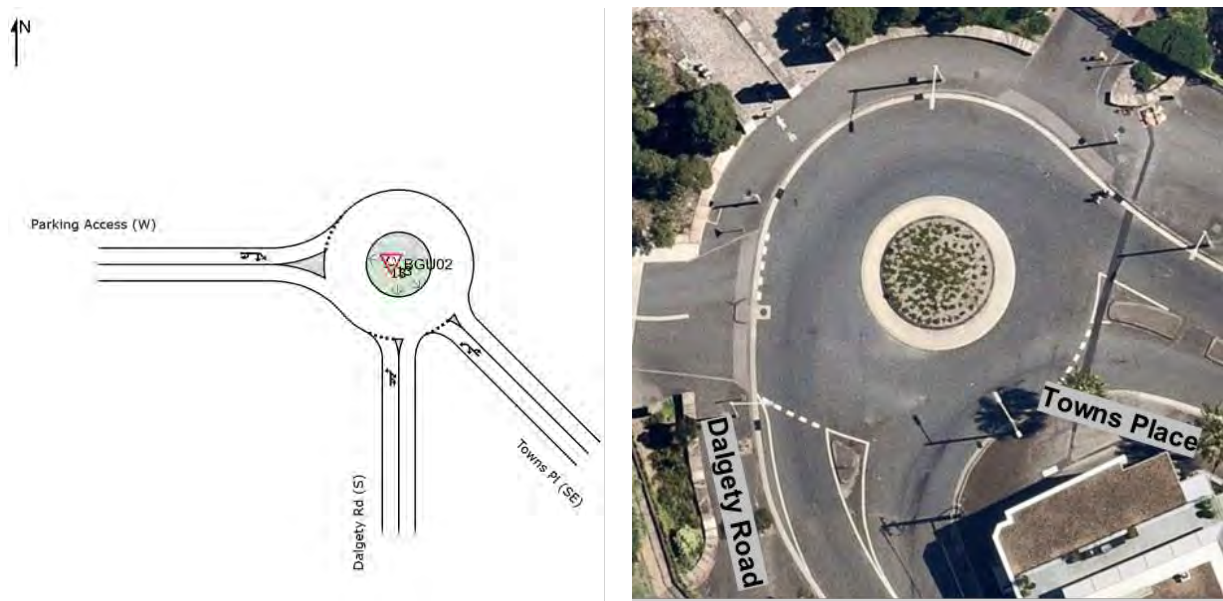

Source: Nearmap, accessed on 24 March 2023

**Figure 5-25 Block 1 – SIDRA Intersection layout (left) and Nearmap aerial imagery (right) of BGU02**

**Table 5-29** presents a performance summary of this intersection.

**Table 5-29 Block 1 – Intersection performance summary of BGU02**

| Intersection                            | Peak       | Approach     | Degree of saturation | Average delay (seconds) | 95 <sup>th</sup> percentile queue (metres) | Level of service (LOS) |
|---|------------|--------------|----------------------|-------------------------|--|------------------------|
| Dalgety Road / Towns Place (Roundabout) | Weekday AM | South        | 0.205                | 8.2                     | 9.3  | LOS A                  |
|   |            | South-east   | 0.135                | 8.3                     | 6.3  | LOS A                  |
|   |            | West         | 0.005                | 1.2                     | 0.2  | LOS A                  |
|   |            | <b>Total</b> | <b>0.135</b>         | <b>8.3</b>              | <b>6.3</b>                                 | <b>LOS A</b>           |
|   | Weekday PM | South        | 0.176                | 8.0                     | 7.7  | LOS A                  |
|   |            | South-east   | 0.134                | 8.3                     | 6.2  | LOS A                  |
|   |            | West         | 0.064                | 1.3                     | 2.6  | LOS A                  |
|   |            | <b>Total</b> | <b>0.134</b>         | <b>8.3</b>              | <b>6.2</b>                                 | <b>LOS A</b>           |
|   | Weekend    | South        | 0.105                | 7.2                     | 4.3  | LOS A                  |
|   |            | South-east   | 0.067                | 8.1                     | 2.9  | LOS A                  |
|   |            | West         | 0.007                | 0.8                     | 0.3  | LOS A                  |
|   |            | <b>Total</b> | <b>0.067</b>         | <b>8.1</b>              | <b>2.9</b>                                 | <b>LOS A</b>           |



Overall, the intersection of Dalgety Road and Towns Place performs satisfactorily at LOS A. The 95<sup>th</sup> percentile queue lengths are accommodated within the approach distances for all approaches.

**5.4.3 BGU03 – Kent Street / Argyle Street**

The priority intersection, composed of Kent Street, Argyle Street and Argyle Place, is located north-east of Barangaroo Station. It connects the local roads of Argyle Street and Argyle Place in Barangaroo with Kent Street, a major local road that runs through the Sydney CBD.

**Figure 5-26** illustrates both the general intersection layout as modelled in SIDRA Intersection and the layout as per aerial imagery.

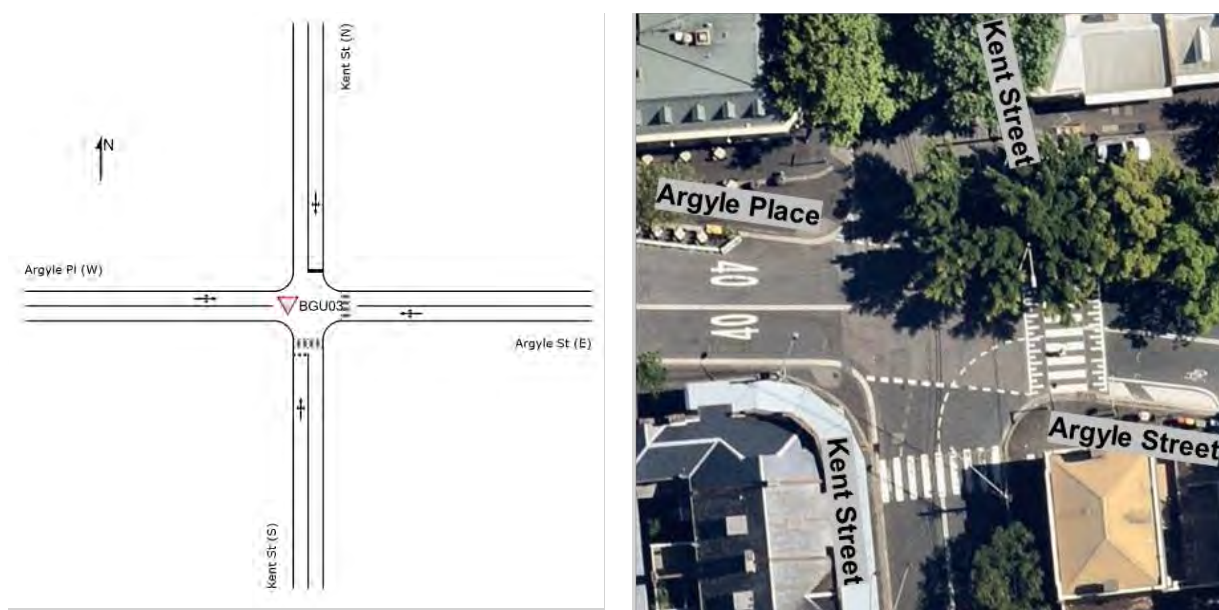

Source: Nearmap, accessed on 24 March 2023

**Figure 5-26 Block 1 – SIDRA Intersection layout (left) and Nearmap aerial imagery (right) of BGU03**

**Table 5-30** presents a performance summary of this intersection.

**Table 5-30 Block 1 – Intersection performance summary of BGU03**

| Intersection   | Peak       | Approach     | Degree of saturation | Average delay (seconds) | 95 <sup>th</sup> percentile queue (metres) | Level of service (LOS) |
|--|------------|--------------|----------------------|-------------------------|--|------------------------|
| Kent Street / Argyle Street<br><br>(Priority – Give Way) | Weekday AM | South        | 0.511                | 13.1                    | 25.5                                       | LOS A                  |
|  |            | East         | 0.224                | 5.0                     | 8.2  | LOS A                  |
|  |            | North        | 0.028                | 9.7                     | 0.7  | LOS A                  |
|  |            | West         | 0.142                | 4.1                     | 5.3  | LOS A                  |
|  |            | <b>Total</b> | <b>0.511</b>         | <b>13.1</b>             | <b>25.5</b>                                | <b>LOS A</b>           |
|  | Weekday PM | South        | 0.414                | 7.8                     | 16.9                                       | LOS A                  |
|  |            | East         | 0.193                | 3.6                     | 7.0  | LOS A                  |
|  |            | North        | 0.032                | 9.2                     | 0.8  | LOS A                  |
|  |            | West         | 0.107                | 3.9                     | 3.6  | LOS A                  |
|  |            | <b>Total</b> | <b>0.032</b>         | <b>9.2</b>              | <b>0.8</b>                                 | <b>LOS A</b>           |
| Weekend  | South      | 0.360        | 6.6                  | 11.7                    | LOS A                                      |                        |

| Intersection | Peak | Approach     | Degree of saturation | Average delay (seconds) | 95 <sup>th</sup> percentile queue (metres) | Level of service (LOS) |
|--------------|------|--------------|----------------------|-------------------------|--|------------------------|
|              |      | East         | 0.172                | 3.9                     | 6.1  | LOS A                  |
|              |      | North        | 0.037                | 8.4                     | 0.9  | LOS A                  |
|              |      | West         | 0.101                | 4.3                     | 3.4  | LOS A                  |
|              |      | <b>Total</b> | <b>0.037</b>         | <b>8.4</b>              | <b>0.9</b>                                 | <b>LOS A</b>           |

Overall, the intersection of Kent Street, Argyle Street and Argyle Place performs satisfactorily at LOS A. The 95<sup>th</sup> percentile queue lengths are accommodated within the approach distances for all approaches.

**5.4.4 BGU04 – Pedestrian Mid-block Crossing at Kent Street near Gas Lane**

The signalised pedestrian mid-block crossing at Kent Street, near Gas Lane, is located south-east of Barangaroo Station. It offers a signalised pedestrian crossing over Kent Street near Gas Lane, a major local road that runs through the Sydney CBD. A dedicated cycleway runs along the east side of Kent Street; however, it was not considered for this assessment. The traffic signals at this intersection are co-ordinated with the intersection of Kent Street, Clarence Street and the Sydney Harbour Bridge on-ramp (BGU05).

Figure 5-27 illustrates both the general intersection layout as modelled in SIDRA Intersection and the layout as per aerial imagery.

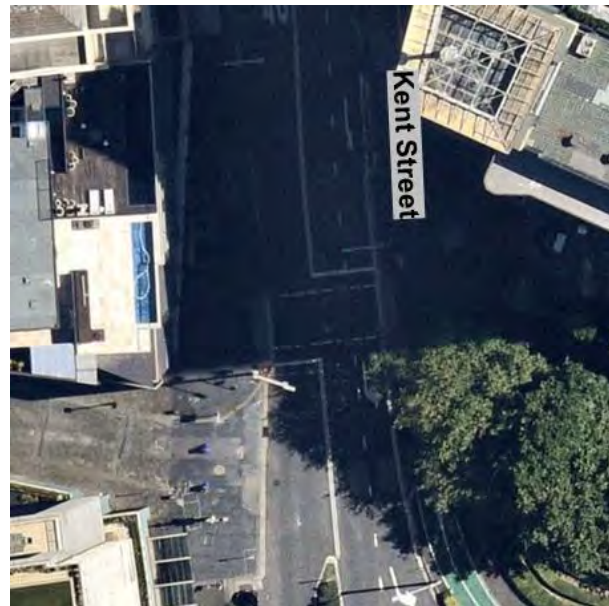
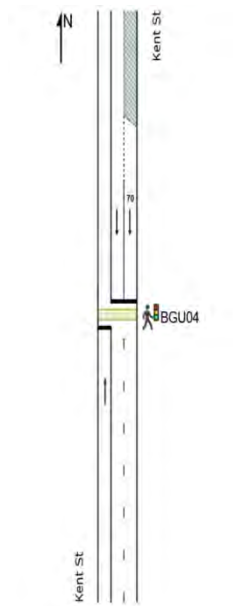

Source: Nearmap, accessed on 24 March 2023

Figure 5-27 Block 1 – SIDRA Intersection layout (left) and Nearmap aerial imagery (right) of BGU04

Table 5-31 presents a performance summary of this intersection.

**Table 5-31 Block 1 – Intersection performance summary of BGU04**

| Intersection   | Peak       | Approach     | Degree of saturation | Average delay (seconds) | 95 <sup>th</sup> percentile queue (metres) | Level of service (LOS) |
|--|------------|--------------|----------------------|-------------------------|--|------------------------|
| Pedestrian Mid-block Crossing at Kent Street near Gas Lane<br><br>(Pedestrian only – Signal) | Weekday AM | South        | 0.421                | 10.8                    | 81.6                                       | LOS A                  |
|  |            | North        | 0.430                | 34.8                    | 39.3                                       | LOS C                  |
|  |            | <b>Total</b> | <b>0.430</b>         | <b>19.4</b>             | <b>81.6</b>                                | <b>LOS B</b>           |
|  | Weekday PM | South        | 0.296                | 8.5                     | 59.9                                       | LOS A                  |
|  |            | North        | 0.621                | 41.8                    | 49.2                                       | LOS C                  |
|  |            | <b>Total</b> | <b>0.621</b>         | <b>23.3</b>             | <b>59.9</b>                                | <b>LOS B</b>           |
|  | Weekend    | South        | 0.245                | 10.2                    | 37.0                                       | LOS A                  |
|  |            | North        | 0.356                | 26.8                    | 24.0                                       | LOS B                  |
|  |            | <b>Total</b> | <b>0.356</b>         | <b>18.0</b>             | <b>37.0</b>                                | <b>LOS B</b>           |

Overall, the pedestrian mid-block crossing at Kent Street, near Gas Lane, performs satisfactorily at LOS B. The 95<sup>th</sup> percentile queue lengths are accommodated within the approach distances for all approaches.

**5.4.5 BGU05 – Kent Street / Sydney Harbour Bridge (SHB) On-ramp**

The signalised intersection, composed of Kent Street, Clarence Street and the Sydney Harbour Bridge (SHB) on-ramp, is located south-east of Barangaroo Station. It connects the major local roads running through the Sydney CBD of Kent Street and Clarence Street with the Sydney Harbour Bridge on-ramp, providing northbound access to the M1 Motorway. A dedicated cycleway runs along the east side of Kent Street and the north side of the SHB on-ramp. Kent St (N) cycleway not assessed. The traffic signals at this intersection are co-ordinated with the pedestrian mid-block crossing at Kent Street, near Gas Lane (BGU04).

**Figure 5-28** illustrates both the general intersection layout as modelled in SIDRA Intersection and the layout as per aerial imagery.

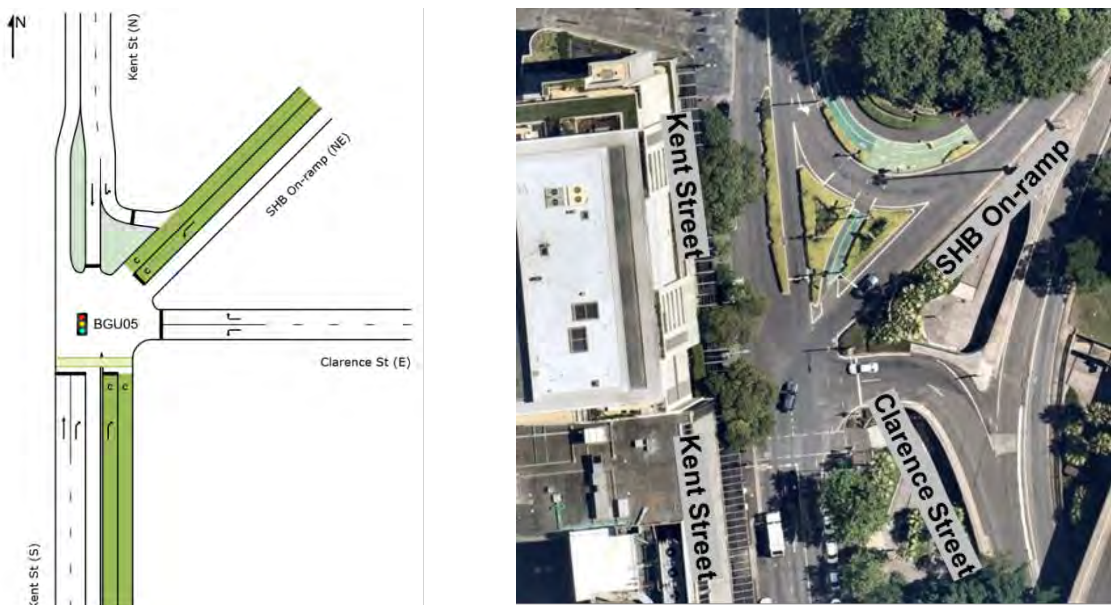

Source: Nearmap, accessed on 24 March 2023

**Figure 5-28 Block 1 – SIDRA Intersection layout (left) and Nearmap aerial imagery (right) of BGU05**

**Table 5-32** presents a performance summary of this intersection.

**Table 5-32 Block 1 – Intersection performance summary of BGU05**

| Intersection  | Peak       | Approach     | Degree of saturation | Average delay (seconds) | 95 <sup>th</sup> percentile queue (metres) | Level of service (LOS) |
|---|------------|--------------|----------------------|-------------------------|--|------------------------|
| Kent Street / Sydney Harbour Bridge (SHB) On-ramp<br>(Signal) | Weekday AM | South        | 0.561                | 16.3                    | 58.2                                       | LOS B                  |
|   |            | East         | 0.894                | 49.7                    | 72.7                                       | LOS D                  |
|   |            | North        | 0.507                | 32.5                    | 56.8                                       | LOS C                  |
|   |            | <b>Total</b> | <b>0.894</b>         | <b>28.3</b>             | <b>72.7</b>                                | <b>LOS B</b>           |
|   | Weekday PM | South        | 0.730                | 11.4                    | 96.2                                       | LOS A                  |
|   |            | East         | 0.576                | 42.4                    | 44.0                                       | LOS C                  |
|   |            | North        | 0.747                | 43.9                    | 52.6                                       | LOS D                  |
|   |            | <b>Total</b> | <b>0.747</b>         | <b>23.8</b>             | <b>96.2</b>                                | <b>LOS B</b>           |
|   | Weekend    | South        | 0.434                | 17.2                    | 43.9                                       | LOS B                  |
|   |            | East         | 0.214                | 26.2                    | 16.9                                       | LOS B                  |
|   |            | North        | 0.602                | 30.2                    | 27.1                                       | LOS C                  |
|   |            | <b>Total</b> | <b>0.602</b>         | <b>22.5</b>             | <b>43.9</b>                                | <b>LOS B</b>           |

Overall, the intersection of Kent Street, Clarence Street and the SHB on-ramp performs satisfactorily at LOS B. The 95<sup>th</sup> percentile queue lengths are accommodated within the approach distances for all approaches.

#### 5.4.6 BGU06 – Hickson Road / Napoleon Street / Sussex Street

The signalised intersection, composed of Hickson Road, Napoleon Street, Sussex Street and a private parking facility is located south of Barangaroo Station. It connects the parking facility exit and local road of Napoleon Street with the regional roads of Hickson Road, which runs along the western waterfront of Barangaroo, and Sussex Street running through the Sydney CBD.

**Figure 5-29** illustrates both the general intersection layout as modelled in SIDRA Intersection and the layout as per aerial imagery.



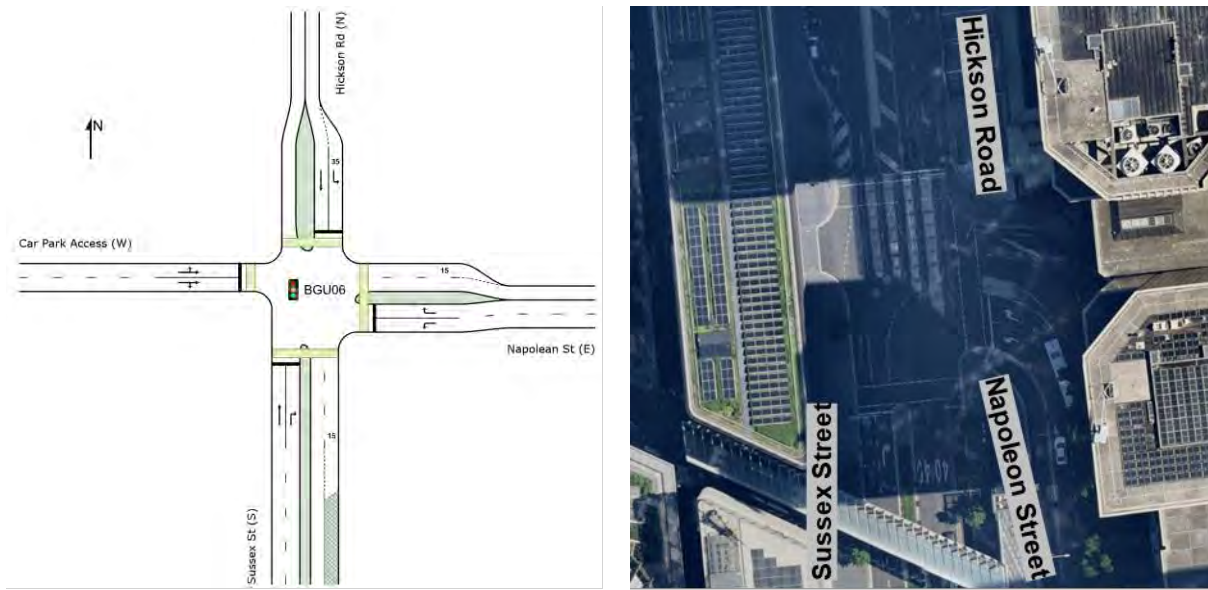

Source: Nearmap, accessed on 24 March 2023

Figure 5-29 Block 1 – SIDRA Intersection layout (left) and Nearmap aerial imagery (right) of BGU06

Table 5-33 presents a performance summary of this intersection.

Table 5-33 Block 1 – Intersection performance summary of BGU06

| Intersection   | Peak       | Approach     | Degree of saturation | Average delay (seconds) | 95 <sup>th</sup> percentile queue (metres) | Level of service (LOS) |
|--|------------|--------------|----------------------|-------------------------|--|------------------------|
| Hickson Road / Napoleon Street / Sussex Street<br>(Signal) | Weekday AM | South        | 0.348                | 12.9                    | 49.7                                       | LOS A                  |
|  |            | East         | 0.511                | 26.1                    | 45.9                                       | LOS B                  |
|  |            | North        | 0.336                | 19.6                    | 41.8                                       | LOS B                  |
|  |            | West         | 0.193                | 44.8                    | 1.5  | LOS D                  |
|  |            | <b>Total</b> | <b>0.511</b>         | <b>18.9</b>             | <b>49.7</b>                                | <b>LOS B</b>           |
|  | Weekday PM | South        | 0.438                | 14.9                    | 69.6                                       | LOS B                  |
|  |            | East         | 0.659                | 32.2                    | 56.9                                       | LOS C                  |
|  |            | North        | 0.479                | 22.6                    | 65.5                                       | LOS B                  |
|  |            | West         | 0.358                | 40.4                    | 9.9  | LOS C                  |
|  |            | <b>Total</b> | <b>0.659</b>         | <b>22.5</b>             | <b>69.6</b>                                | <b>LOS B</b>           |
|  | Weekend    | South        | 0.322                | 10.9                    | 43.0                                       | LOS A                  |
|  |            | East         | 0.419                | 25.7                    | 36.9                                       | LOS B                  |
|  |            | North        | 0.415                | 18.2                    | 51.7                                       | LOS B                  |
|  |            | West         | 0.074                | 41.4                    | 0.6  | LOS C                  |
|  |            | <b>Total</b> | <b>0.419</b>         | <b>17.3</b>             | <b>51.7</b>                                | <b>LOS B</b>           |

Overall, the intersection of Hickson Road, Napoleon Street and Sussex Street performs satisfactorily at LOS B. The 95<sup>th</sup> percentile queue lengths are accommodated within the approach distances for all approaches.

**5.4.7 BGU07 – Margaret Street / Kent Street / Napoleon Street**

The signalised intersection, composed of Margaret Street, Kent Street and Napoleon Street, is located south-east of Barangaroo Station. It connects the local roads of Napoleon Street and Margaret Street in the Sydney CBD with Kent Street, a major local road that runs through the Sydney CBD. A dedicated cycleway runs along the east side of Kent Street.

**Figure 5-30** illustrates both the general intersection layout as modelled in SIDRA Intersection and the layout as per aerial imagery.

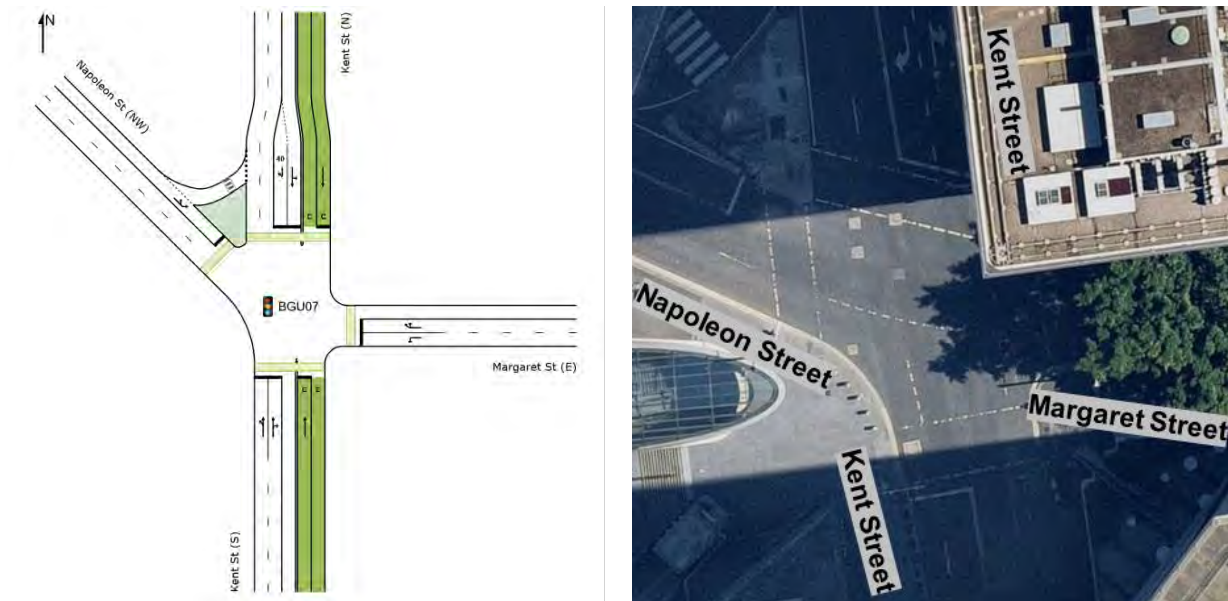

Source: Nearmap, accessed on 24 March 2023

**Figure 5-30 Block 1 – SIDRA Intersection layout (left) and Nearmap aerial imagery (right) of BGU07**

**Table 5-34** presents a performance summary of this intersection.

**Table 5-34 Block 1 – Intersection performance summary of BGU07**

| Intersection   | Peak       | Approach     | Degree of saturation | Average delay (seconds) | 95 <sup>th</sup> percentile queue (metres) | Level of service (LOS) |
|--|------------|--------------|----------------------|-------------------------|--|------------------------|
| Margaret Street / Kent Street / Napoleon Street (Signal) | Weekday AM | South        | 0.496                | 24.7                    | 86.3                                       | LOS B                  |
|  |            | East         | 0.778                | 40.9                    | 65.3                                       | LOS C                  |
|  |            | North        | 0.248                | 22.5                    | 25.6                                       | LOS B                  |
|  |            | North-west   | 0.314                | 13.4                    | 22.3                                       | LOS A                  |
|  |            | <b>Total</b> | <b>0.778</b>         | <b>26.9</b>             | <b>86.3</b>                                | <b>LOS B</b>           |
|  | Weekday PM | South        | 0.474                | 22.0                    | 91.2                                       | LOS B                  |
|  |            | East         | 0.657                | 35.5                    | 65.3                                       | LOS C                  |
|  |            | North        | 0.278                | 24.6                    | 19.6                                       | LOS B                  |
|  |            | North-west   | 0.327                | 11.9                    | 30.6                                       | LOS A                  |
|  |            | <b>Total</b> | <b>0.657</b>         | <b>23.6</b>             | <b>91.2</b>                                | <b>LOS B</b>           |
|  | Weekend    | South        | 0.318                | 15.4                    | 40.0                                       | LOS B                  |
| East   |            | 0.349        | 22.6                 | 34.5                    | LOS B                                      |                        |

| Intersection | Peak | Approach     | Degree of saturation | Average delay (seconds) | 95 <sup>th</sup> percentile queue (metres) | Level of service (LOS) |
|--------------|------|--------------|----------------------|-------------------------|--|------------------------|
|              |      | North        | 0.335                | 24.5                    | 28.0                                       | LOS B                  |
|              |      | North-west   | 0.261                | 10.9                    | 20.6                                       | LOS A                  |
|              |      | <b>Total</b> | <b>0.349</b>         | <b>17.8</b>             | <b>40.0</b>                                | <b>LOS B</b>           |

Overall, the intersection of Margaret Street, Kent Street and Napoleon Street performs satisfactorily at LOS B. The 95<sup>th</sup> percentile queue lengths are accommodated within the approach distances for all approaches.

**5.4.8 BGU08 – Margaret Street / Clarence Street**

The signalised intersection, composed of Margaret Street and Clarence Street, is located south-east of Barangaroo Station. It connects the local road of Margaret Street with Clarence Street, a major local road that runs through the Sydney CBD.

Figure 5-31 illustrates both the general intersection layout as modelled in SIDRA Intersection and the layout as per aerial imagery.

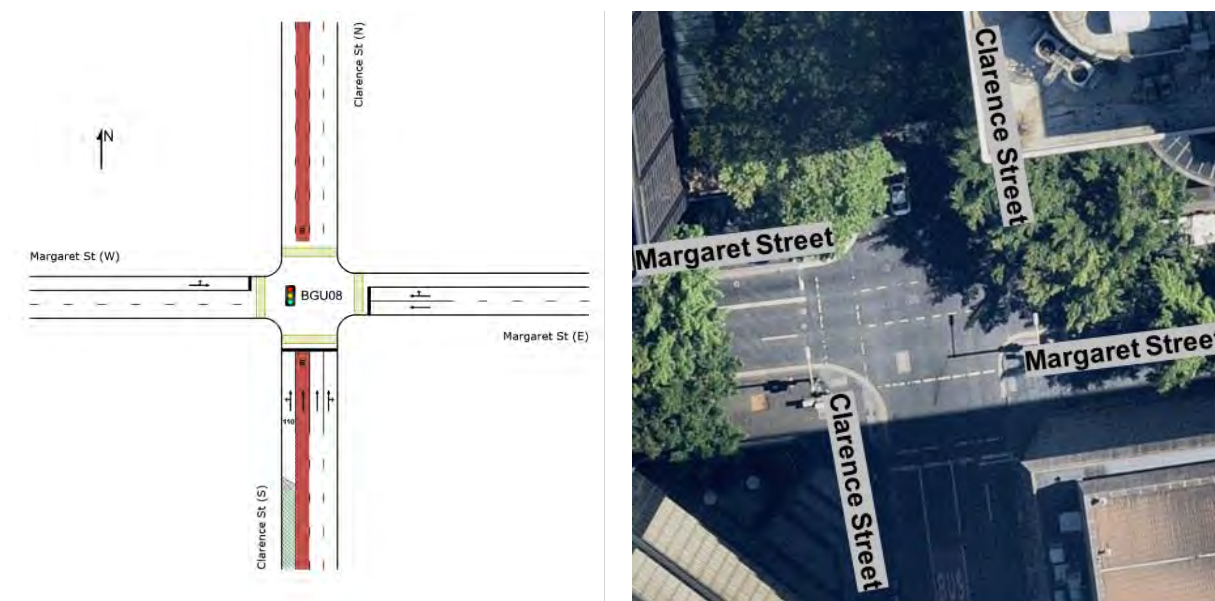

Source: Nearmap, accessed on 24 March 2023

Figure 5-31 Block 1 – SIDRA Intersection layout (left) and Nearmap aerial imagery (right) of BGU08

Table 5-35 presents a performance summary of this intersection.

Table 5-35 Block 1 – Intersection performance summary of BGU08

| Intersection                      | Peak       | Approach     | Degree of saturation | Average delay (seconds) | 95 <sup>th</sup> percentile queue (metres) | Level of service (LOS) |
|-----------------------------------|------------|--------------|----------------------|-------------------------|--|------------------------|
| Margaret Street / Clarence Street | Weekday AM | South        | 0.518                | 26.2                    | 67.7                                       | LOS B                  |
|                                   |            | East         | 0.481                | 15.4                    | 53.7                                       | LOS B                  |
|                                   |            | West         | 0.686                | 44.7                    | 50.8                                       | LOS D                  |
|                                   |            | <b>Total</b> | <b>0.686</b>         | <b>24.8</b>             | <b>67.7</b>                                | <b>LOS B</b>           |

| Intersection | Peak       | Approach     | Degree of saturation | Average delay (seconds) | 95 <sup>th</sup> percentile queue (metres) | Level of service (LOS) |
|--------------|------------|--------------|----------------------|-------------------------|--|------------------------|
| (Signal)     | Weekday PM | South        | 0.527                | 27.0                    | 85.6                                       | LOS B                  |
|              |            | East         | 0.389                | 15.0                    | 43.2                                       | LOS B                  |
|              |            | West         | 0.516                | 42.2                    | 46.1                                       | LOS C                  |
|              |            | <b>Total</b> | <b>0.527</b>         | <b>25.5</b>             | <b>85.6</b>                                | <b>LOS B</b>           |
|              | Weekend    | South        | 0.334                | 16.1                    | 33.3                                       | LOS B                  |
|              |            | East         | 0.169                | 12.7                    | 19.4                                       | LOS A                  |
|              |            | West         | 0.277                | 25.8                    | 24.8                                       | LOS B                  |
|              |            | <b>Total</b> | <b>0.334</b>         | <b>16.3</b>             | <b>33.3</b>                                | <b>LOS B</b>           |

Overall, the intersection of Margaret Street and Clarence Street performs satisfactorily at LOS B. The 95<sup>th</sup> percentile queue lengths are accommodated within the approach distances for all approaches.

**5.4.9 BGU09 – Margaret Street / York Street**

The signalised intersection, composed of Margaret Street and York Street, is located south-east of Barangaroo Station. It connects the local road of Margaret Street with York Street, a major local road that runs through the Sydney CBD.

Figure 5-32 illustrates both the general intersection layout as modelled in SIDRA Intersection and the layout as per aerial imagery.

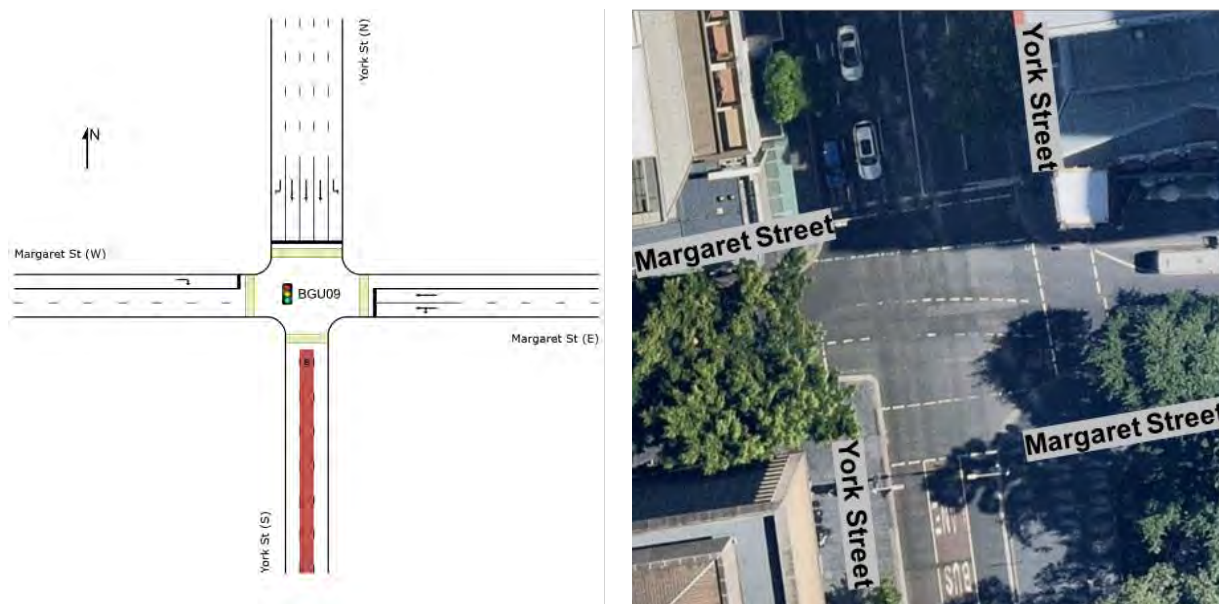

Source: Nearmap, accessed on 24 March 2023

Figure 5-32 Block 1 – SIDRA Intersection layout (left) and Nearmap aerial imagery (right) of BGU09

Table 5-36 presents a performance summary of this intersection.



**Table 5-36 Block 1 – Intersection performance summary of BGU09**

| Intersection                           | Peak       | Approach     | Degree of saturation | Average delay (seconds) | 95 <sup>th</sup> percentile queue (metres) | Level of service (LOS) |
|--|------------|--------------|----------------------|-------------------------|--|------------------------|
| Margaret Street / York Street (Signal) | Weekday AM | East         | 0.248                | 33.1                    | 31.1                                       | LOS C                  |
|  |            | North        | 0.437                | 12.8                    | 69.2                                       | LOS A                  |
|  |            | West         | 0.455                | 45.1                    | 27.7                                       | LOS D                  |
|  |            | <b>Total</b> | <b>0.455</b>         | <b>16.9</b>             | <b>69.2</b>                                | <b>LOS B</b>           |
|  | Weekday PM | East         | 0.322                | 32.3                    | 41.2                                       | LOS C                  |
|  |            | North        | 0.318                | 13.6                    | 55.4                                       | LOS A                  |
|  |            | West         | 0.420                | 43.9                    | 24.5                                       | LOS D                  |
|  |            | <b>Total</b> | <b>0.420</b>         | <b>18.4</b>             | <b>55.4</b>                                | <b>LOS B</b>           |
|  | Weekend    | East         | 0.091                | 23.5                    | 9.3  | LOS B                  |
|  |            | North        | 0.238                | 14.0                    | 35.3                                       | LOS A                  |
|  |            | West         | 0.139                | 28.9                    | 11.2                                       | LOS C                  |
|  |            | <b>Total</b> | <b>0.238</b>         | <b>15.6</b>             | <b>35.3</b>                                | <b>LOS B</b>           |

Overall, the intersection of Margaret Street and York Street performs satisfactorily at LOS B. The 95<sup>th</sup> percentile queue lengths are accommodated within the approach distances for all approaches.

**5.4.10 BGU10 – Pedestrian Mid-block Crossing at Sussex Street under Exchange Place**

The signalised pedestrian mid-block crossing at Sussex Street, under Exchange Place, is located south of Barangaroo Station. It offers a signalised pedestrian crossing over Sussex Street, a regional road that runs through the Sydney CBD.

**Figure 5-33** illustrates both the general intersection layout as modelled in SIDRA Intersection and the layout as per aerial imagery.

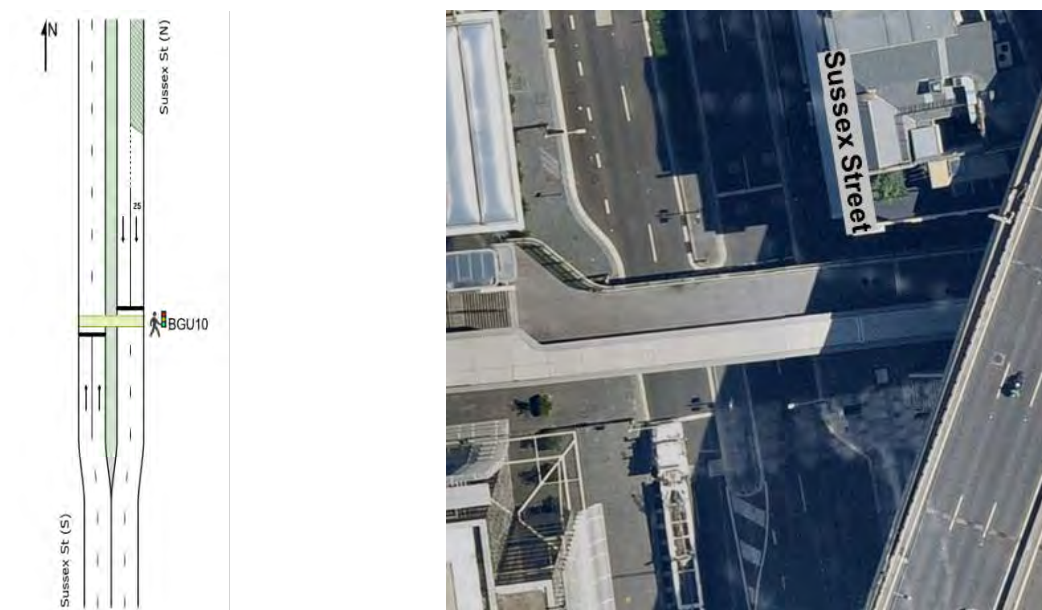

Source: Nearmap, accessed on 24 March 2023

**Figure 5-33 Block 1 – SIDRA Intersection layout (left) and Nearmap aerial imagery (right) of BGU10**

Table 5-37 presents a performance summary of this intersection.

Table 5-37 Block 1 – Intersection performance summary of BGU10

| Intersection  | Peak       | Approach     | Degree of saturation | Average delay (seconds) | 95 <sup>th</sup> percentile queue (metres) | Level of service (LOS) |
|---|------------|--------------|----------------------|-------------------------|--|------------------------|
| Pedestrian Mid-block Crossing at Sussex Street under Exchange Place | Weekday AM | South        | 0.175                | 2.8                     | 17.5                                       | LOS A                  |
|   |            | North        | 0.129                | 2.7                     | 12.3                                       | LOS A                  |
|   |            | <b>Total</b> | <b>0.175</b>         | <b>2.8</b>              | <b>17.5</b>                                | <b>LOS A</b>           |
|   | Weekday PM | South        | 0.196                | 2.9                     | 20.1                                       | LOS A                  |
|   |            | North        | 0.183                | 2.8                     | 18.4                                       | LOS A                  |
|   |            | <b>Total</b> | <b>0.196</b>         | <b>2.9</b>              | <b>20.1</b>                                | <b>LOS A</b>           |
| (Pedestrian only – Signal)  | Weekend    | South        | 0.130                | 2.7                     | 12.6                                       | LOS A                  |
|   |            | North        | 0.108                | 2.7                     | 10.2                                       | LOS A                  |
|   |            | <b>Total</b> | <b>0.130</b>         | <b>2.7</b>              | <b>12.6</b>                                | <b>LOS A</b>           |

Overall, the pedestrian mid-block crossing at Sussex Street under Exchange Place performs satisfactorily at LOS A. The 95<sup>th</sup> percentile queue lengths are accommodated within the approach distances for all approaches.

**5.4.11 BGU11 – Pedestrian Mid-block Crossing at Kent Street near Margaret Street**

The signalised pedestrian mid-block crossing at Kent Street, near Margaret Street, is located south of Barangaroo Station. It offers a signalised pedestrian crossing over Kent Street near Margaret Street, a major local road that runs through the Sydney CBD. A dedicated cycleway runs along the east side of Kent Street.

Figure 5-34 illustrates both the general intersection layout as modelled in SIDRA Intersection and the layout as per aerial imagery.

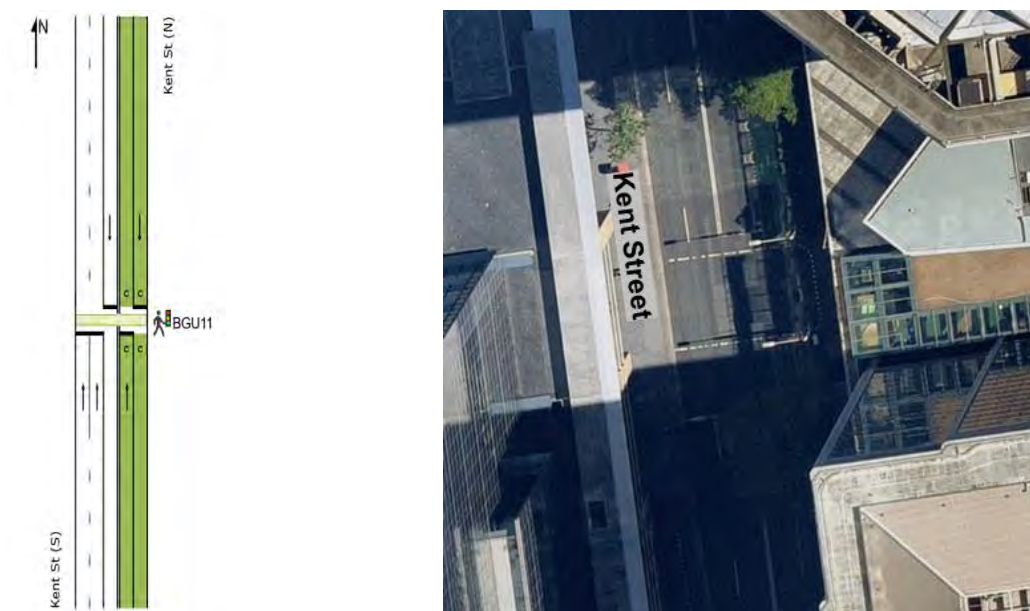

Source: Nearmap, accessed on 24 March 2023

Figure 5-34 Block 1 – SIDRA Intersection layout (left) and Nearmap aerial imagery (right) of BGU11

**Table 5-38** presents a performance summary of this intersection.

**Table 5-38 Block 1 – Intersection performance summary of BGU11**

| Intersection  | Peak       | Approach     | Degree of saturation | Average delay (seconds) | 95 <sup>th</sup> percentile queue (metres) | Level of service (LOS) |
|---|------------|--------------|----------------------|-------------------------|--|------------------------|
| Pedestrian Mid-block Crossing at Kent Street near Margaret Street | Weekday AM | South        | 0.442                | 9.9                     | 40.4                                       | LOS A                  |
|   |            | North        | 0.137                | 8.4                     | 10.7                                       | LOS A                  |
|   |            | <b>Total</b> | <b>0.442</b>         | <b>9.7</b>              | <b>40.4</b>                                | <b>LOS A</b>           |
|   | Weekday PM | South        | 0.402                | 9.7                     | 36.1                                       | LOS A                  |
|   |            | North        | 0.185                | 8.5                     | 15.0                                       | LOS A                  |
|   |            | <b>Total</b> | <b>0.402</b>         | <b>9.4</b>              | <b>36.1</b>                                | <b>LOS A</b>           |
| (Pedestrian only – Signal)  | Weekend    | South        | 0.242                | 9.2                     | 20.0                                       | LOS A                  |
|   |            | North        | 0.207                | 8.9                     | 16.8                                       | LOS A                  |
|   |            | <b>Total</b> | <b>0.242</b>         | <b>9.1</b>              | <b>20.0</b>                                | <b>LOS A</b>           |

Overall, the pedestrian mid-block crossing at Kent Street, near Margaret Street, performs satisfactorily at LOS A. The 95<sup>th</sup> percentile queue lengths are accommodated within the approach distances for all approaches.

**5.4.12 BGU12 – Sussex Street / Erskine Street**

The signalised intersection, composed of Sussex Street and Erskine Street, is located south of Barangaroo Station. It connects the regional road of Sussex Street running through the Sydney CBD with the local road of Erskine Street.

**Figure 5-35** illustrates both the general intersection layout as modelled in SIDRA Intersection and the layout as per aerial imagery.

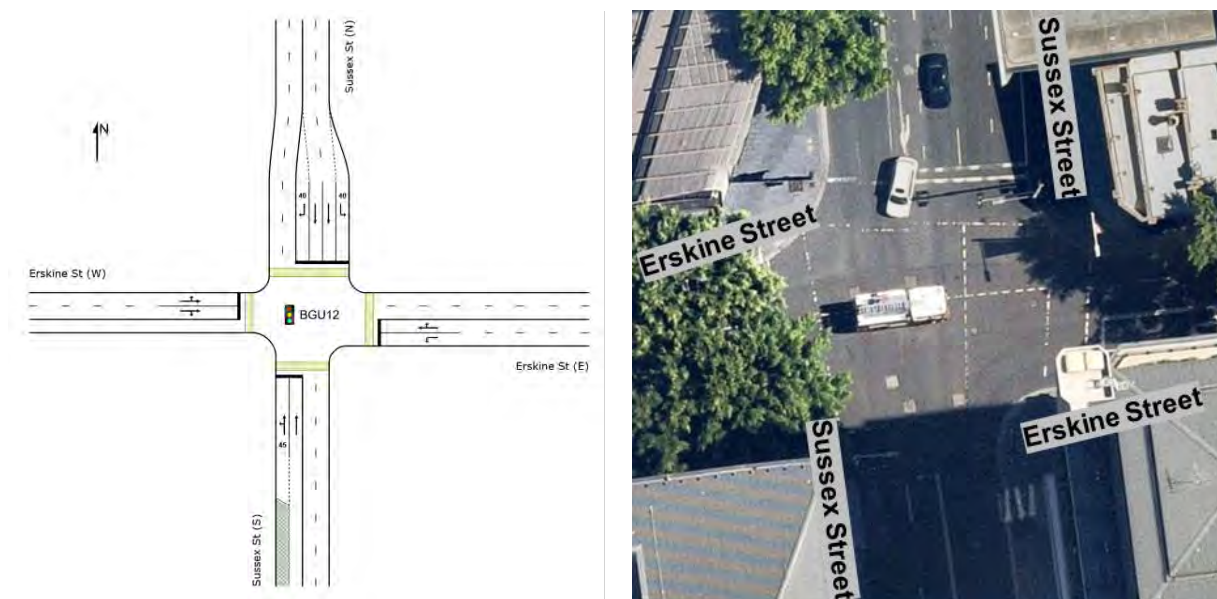

Source: Nearmap, accessed on 24 March 2023

**Figure 5-35 Block 1 – SIDRA Intersection layout (left) and Nearmap aerial imagery (right) of BGU12**

**Table 5-39** presents a performance summary of this intersection.

Table 5-39 Block 1 – Intersection performance summary of BGU12

| Intersection                               | Peak       | Approach     | Degree of saturation | Average delay (seconds) | 95 <sup>th</sup> percentile queue (metres) | Level of service (LOS) |
|--|------------|--------------|----------------------|-------------------------|--|------------------------|
| Sussex Street / Erskine Street<br>(Signal) | Weekday AM | South        | 0.464                | 32.5                    | 62.5                                       | LOS C                  |
|  |            | East         | 0.365                | 9.3                     | 42.3                                       | LOS A                  |
|  |            | North        | 0.186                | 23.1                    | 27.0                                       | LOS B                  |
|  |            | West         | 0.333                | 14.2                    | 58.0                                       | LOS A                  |
|  |            | <b>Total</b> | <b>0.464</b>         | <b>18.8</b>             | <b>62.5</b>                                | <b>LOS B</b>           |
|  | Weekday PM | South        | 0.466                | 30.9                    | 65.1                                       | LOS C                  |
|  |            | East         | 0.449                | 10.0                    | 54.8                                       | LOS A                  |
|  |            | North        | 0.302                | 22.5                    | 47.0                                       | LOS B                  |
|  |            | West         | 0.533                | 17.6                    | 63.4                                       | LOS B                  |
|  |            | <b>Total</b> | <b>0.533</b>         | <b>19.6</b>             | <b>65.1</b>                                | <b>LOS B</b>           |
|  | Weekend    | South        | 0.278                | 26.8                    | 38.3                                       | LOS B                  |
|  |            | East         | 0.401                | 8.5                     | 42.3                                       | LOS A                  |
|  |            | North        | 0.201                | 20.8                    | 30.3                                       | LOS B                  |
|  |            | West         | 0.748                | 21.6                    | 73.4                                       | LOS B                  |
|  |            | <b>Total</b> | <b>0.748</b>         | <b>18.3</b>             | <b>73.4</b>                                | <b>LOS B</b>           |

Overall, the intersection of Sussex Street and Erskine Street performs satisfactorily at LOS B. The 95<sup>th</sup> percentile queue lengths are accommodated within the approach distances for all approaches.

#### 5.4.13 BGU13 – Kent Street / Erskine Street

The signalised intersection, composed of Kent Street and Erskine Street, is located south of Barangaroo Station. It connects the local road of Erskine Street with Kent Street, a major local road that runs through the Sydney CBD. A dedicated cycleway runs along the east side of Kent Street.

**Figure 5-36** illustrates both the general intersection layout as modelled in SIDRA Intersection and the layout as per aerial imagery.



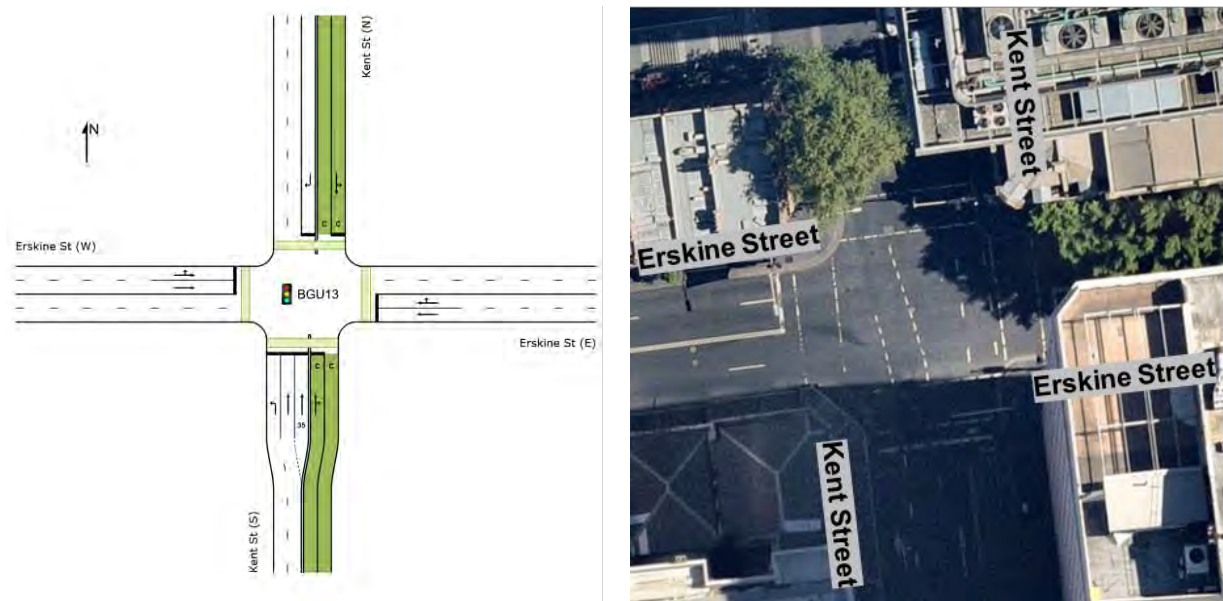

Source: Nearmap, accessed on 24 March 2023

Figure 5-36 Block 1 – SIDRA Intersection layout (left) and Nearmap aerial imagery (right) of BGU13

Table 5-40 presents a performance summary of this intersection.

Table 5-40 Block 1 – Intersection performance summary of BGU13

| Intersection                          | Peak       | Approach     | Degree of saturation | Average delay (seconds) | 95 <sup>th</sup> percentile queue (metres) | Level of service (LOS) |
|---------------------------------------|------------|--------------|----------------------|-------------------------|--|------------------------|
| Kent Street / Erskine Street (Signal) | Weekday AM | South        | 0.348                | 18.8                    | 57.4                                       | LOS B                  |
|                                       |            | East         | 0.255                | 25.0                    | 36.2                                       | LOS B                  |
|                                       |            | North        | 0.688                | 34.4                    | 33.9                                       | LOS C                  |
|                                       |            | West         | 0.297                | 17.1                    | 30.6                                       | LOS B                  |
|                                       |            | <b>Total</b> | <b>0.688</b>         | <b>21.3</b>             | <b>57.4</b>                                | <b>LOS B</b>           |
|                                       | Weekday PM | South        | 0.339                | 15.4                    | 59.3                                       | LOS B                  |
|                                       |            | East         | 0.349                | 32.5                    | 39.6                                       | LOS C                  |
|                                       |            | North        | 0.801                | 28.2                    | 51.7                                       | LOS B                  |
|                                       |            | West         | 0.364                | 26.9                    | 36.5                                       | LOS B                  |
|                                       |            | <b>Total</b> | <b>0.801</b>         | <b>22.6</b>             | <b>59.3</b>                                | <b>LOS B</b>           |
|                                       | Weekend    | South        | 0.192                | 18.5                    | 29.9                                       | LOS B                  |
|                                       |            | East         | 0.489                | 44.8                    | 42.7                                       | LOS D                  |
|                                       |            | North        | 0.715                | 43.3                    | 45.5                                       | LOS D                  |
|                                       |            | West         | 0.367                | 27.1                    | 35.9                                       | LOS B                  |
|                                       |            | <b>Total</b> | <b>0.715</b>         | <b>31.4</b>             | <b>45.5</b>                                | <b>LOS C</b>           |

Overall, the intersection of Kent Street and Erskine Street performs satisfactorily at LOS C or better. The 95<sup>th</sup> percentile queue lengths are accommodated within the approach distances for all approaches.

**5.4.14 BGU14 – Sussex Street / King Street**

The signalised intersection, composed of Sussex Street and King Street, is located south of Barangaroo Station. It connects the King Street Western Distributor (A1) off-ramp with the regional road of Sussex Street, running through the Sydney CBD. A dedicated cycleway runs along the north side of King Street.

Figure 5-37 illustrates both the general intersection layout as modelled in SIDRA Intersection and the layout as per aerial imagery.

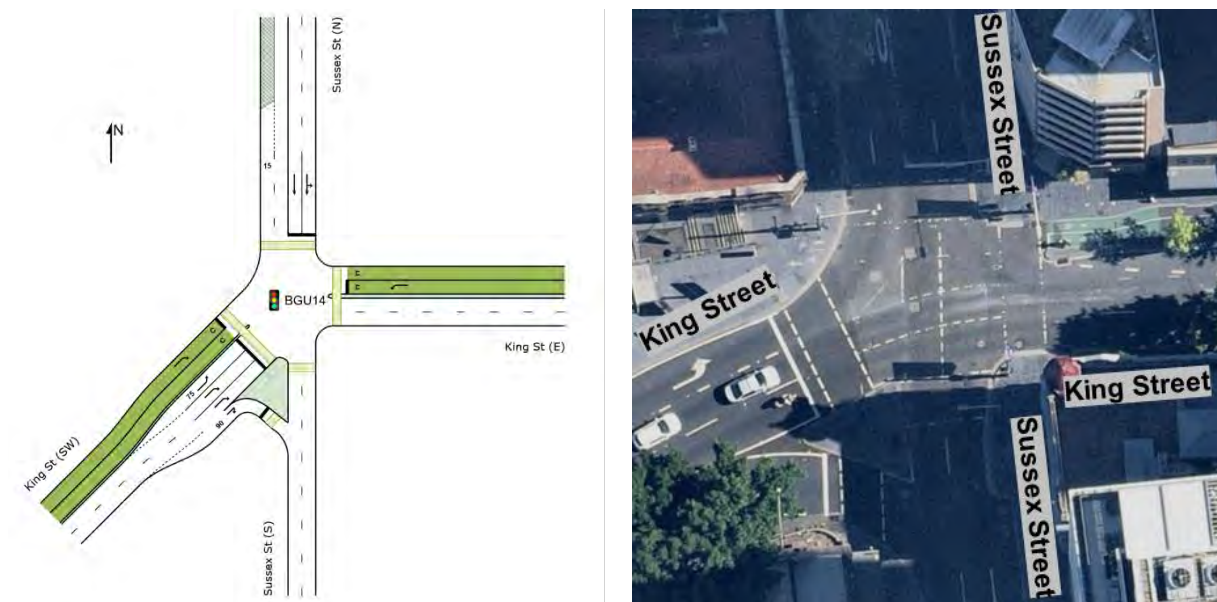

Source: Nearmap, accessed on 24 March 2023

Figure 5-37 Block 1 – SIDRA Intersection layout (left) and Nearmap aerial imagery (right) of BGU14

Table 5-41 presents a performance summary of this intersection.

Table 5-41 Block 1 – Intersection performance summary of BGU14

| Intersection                         | Peak       | Approach     | Degree of saturation | Average delay (seconds) | 95 <sup>th</sup> percentile queue (metres) | Level of service (LOS) |
|--------------------------------------|------------|--------------|----------------------|-------------------------|--|------------------------|
| Sussex Street / King Street (Signal) | Weekday AM | North        | 0.905                | 52.3                    | 129.0                                      | LOS D                  |
|                                      |            | South-west   | 0.527                | 15.5                    | 97.3                                       | LOS B                  |
|                                      |            | <b>Total</b> | <b>0.905</b>         | <b>24.1</b>             | <b>129.0</b>                               | <b>LOS B</b>           |
|                                      | Weekday PM | North        | 0.665                | 21.4                    | 141.6                                      | LOS B                  |
|                                      |            | South-west   | 0.575                | 22.8                    | 106.7                                      | LOS B                  |
|                                      |            | <b>Total</b> | <b>0.665</b>         | <b>23.4</b>             | <b>141.6</b>                               | <b>LOS B</b>           |
|                                      | Weekend    | North        | 0.492                | 17.6                    | 95.6                                       | LOS B                  |
|                                      |            | South-west   | 0.568                | 23.7                    | 102.0                                      | LOS B                  |
|                                      |            | <b>Total</b> | <b>0.568</b>         | <b>21.5</b>             | <b>102.0</b>                               | <b>LOS B</b>           |

Overall, the intersection of Sussex Street and King Street performs satisfactorily at LOS B. The 95<sup>th</sup> percentile queue lengths are accommodated within the approach distances for all approaches.

**5.4.15 BGU15 – Kent Street / King Street**

The signalised intersection, composed of Kent Street and King Street, is located south of Barangaroo Station. It connects the local road of King Street with Kent Street, a major local road that runs through the Sydney CBD. A dedicated cycleway runs along the east side of Kent Street and north side of King Street.

**Figure 5-38** illustrates both the general intersection layout as modelled in SIDRA Intersection and the layout as per aerial imagery.



Source: Nearmap, accessed on 24 March 2023

**Figure 5-38 Block 1 – SIDRA Intersection layout (left) and Nearmap aerial imagery (right) of BGU15**

**Table 5-42** presents a performance summary of this intersection.

**Table 5-42 Block 1 – Intersection performance summary of BGU15**

| Intersection                          | Peak       | Approach     | Degree of saturation | Average delay (seconds) | 95 <sup>th</sup> percentile queue (metres) | Level of service (LOS) |
|---------------------------------------|------------|--------------|----------------------|-------------------------|--|------------------------|
| Kent Street / King Street<br>(Signal) | Weekday AM | South        | 0.515                | 36.1                    | 60.8                                       | LOS C                  |
|                                       |            | West         | 0.549                | 12.2                    | 71.6                                       | LOS A                  |
|                                       |            | <b>Total</b> | <b>0.549</b>         | <b>20.6</b>             | <b>71.6</b>                                | <b>LOS B</b>           |
|                                       | Weekday PM | South        | 0.520                | 32.9                    | 71.3                                       | LOS C                  |
|                                       |            | West         | 0.502                | 12.6                    | 53.1                                       | LOS A                  |
|                                       |            | <b>Total</b> | <b>0.520</b>         | <b>23.3</b>             | <b>71.3</b>                                | <b>LOS B</b>           |
|                                       | Weekend    | South        | 0.376                | 28.8                    | 53.7                                       | LOS C                  |
|                                       |            | West         | 0.497                | 14.9                    | 55.4                                       | LOS B                  |
|                                       |            | <b>Total</b> | <b>0.497</b>         | <b>19.5</b>             | <b>55.4</b>                                | <b>LOS B</b>           |

Overall, the intersection of Kent Street and King Street performs satisfactorily at LOS B. The 95<sup>th</sup> percentile queue on King Street (west approach) extends back to Sussex Street during the weekday AM peak hour.

**5.4.16 BGU16 – New Pedestrian Mid-block Crossing at New Hickson Road (north of Metro Station)**

The signalised pedestrian mid-block crossing at New Hickson Road (north of the metro station) is located directly east of Barangaroo Station. During Block 1, the mid-block crossing was under construction and non-operational. It was not assessed as part of the Block 1 study.

**5.4.17 BGU17 – New Pedestrian Mid-block Crossing at New Hickson Road (south of Metro Station)**

The signalised pedestrian mid-block crossing at New Hickson Road (south of the metro station) is located directly east of Barangaroo Station. During Block 1, the mid-block crossing was under construction and non-operational. It was not assessed as part of the Block 1 study.

**5.4.18 BGU18 – Shelley Street / Erskine Street**

The signalised intersection, composed of Shelley Street and Erskine Street, is located south of Barangaroo Station. It connects the local roads of Erskine Street and Shelley Street in the Sydney CBD near the King Street Wharf.

Figure 5-39 illustrates both the general intersection layout as modelled in SIDRA Intersection and the layout as per aerial imagery.

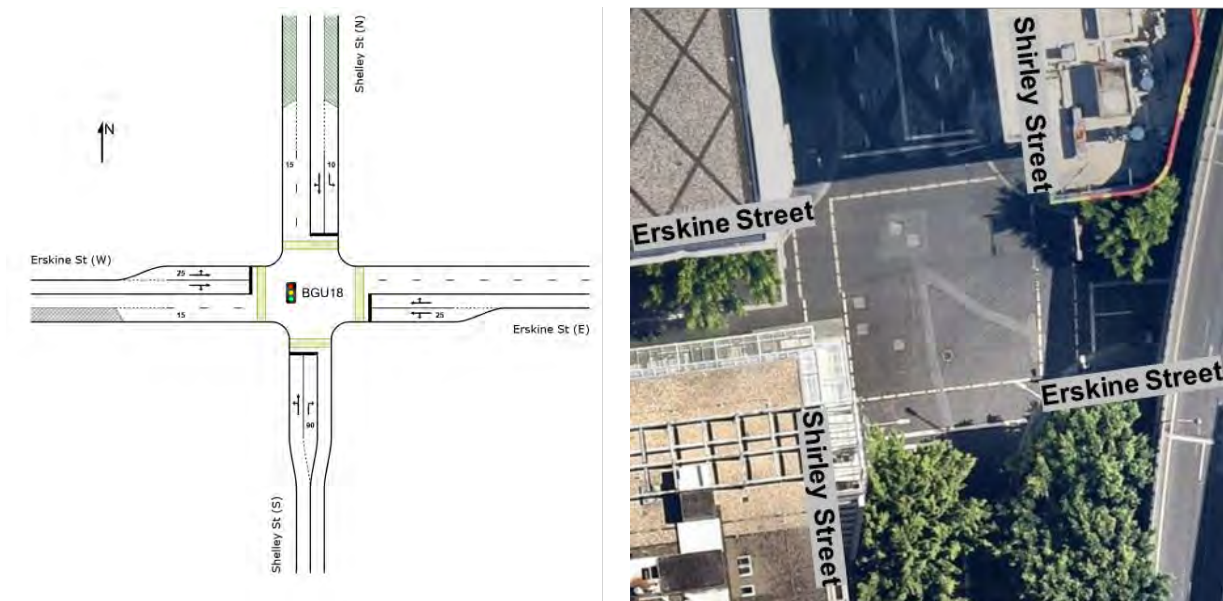

Source: Nearmap, accessed on 24 March 2023

Figure 5-39 Block 1 – SIDRA Intersection layout (left) and Nearmap aerial imagery (right) of BGU18

Table 5-43 presents a performance summary of this intersection.

Table 5-43 Block 1 – Intersection performance summary of BGU18

| Intersection                             | Peak       | Approach     | Degree of saturation | Average delay (seconds) | 95 <sup>th</sup> percentile queue (metres) | Level of service (LOS) |
|--|------------|--------------|----------------------|-------------------------|--|------------------------|
| Shelley Street / Erskine Street (Signal) | Weekday AM | South        | 0.568                | 15.8                    | 39.9                                       | LOS B                  |
|  |            | East         | 0.291                | 14.9                    | 17.7                                       | LOS B                  |
|  |            | North        | 0.235                | 15.5                    | 12.1                                       | LOS B                  |
|  |            | West         | 0.134                | 11.1                    | 9.5  | LOS A                  |
|  |            | <b>Total</b> | <b>0.568</b>         | <b>14.8</b>             | <b>39.9</b>                                | <b>LOS B</b>           |



| Intersection | Peak       | Approach     | Degree of saturation | Average delay (seconds) | 95 <sup>th</sup> percentile queue (metres) | Level of service (LOS) |
|--------------|------------|--------------|----------------------|-------------------------|--|------------------------|
|              | Weekday PM | South        | 0.687                | 18.9                    | 33.3                                       | LOS B                  |
|              |            | East         | 0.285                | 15.5                    | 18.0                                       | LOS B                  |
|              |            | North        | 0.470                | 16.1                    | 24.8                                       | LOS B                  |
|              |            | West         | 0.240                | 12.2                    | 13.8                                       | LOS A                  |
|              |            | <b>Total</b> | <b>0.687</b>         | <b>16.0</b>             | <b>33.3</b>                                | <b>LOS B</b>           |
|              | Weekend    | South        | 0.975                | 45.7                    | 73.6                                       | LOS D                  |
|              |            | East         | 0.228                | 13.9                    | 15.5                                       | LOS A                  |
|              |            | North        | 0.204                | 13.3                    | 15.2                                       | LOS A                  |
|              |            | West         | 0.251                | 12.6                    | 18.8                                       | LOS A                  |
|              |            | <b>Total</b> | <b>0.975</b>         | <b>24.5</b>             | <b>73.6</b>                                | <b>LOS B</b>           |

Overall, the intersection of Shelley Street and Erskine Street performs satisfactorily at LOS B. The 95<sup>th</sup> percentile queue lengths are accommodated within the approach distances for all approaches.

## 5.5 Martin Place Station

Martin Place Station is a new underground station and the fifth stop on the City & Southwest Line (towards Sydenham). It is located to west of the existing Martin Place Station (Sydney Trains) in Martin Place. Martin Place Station will have two station entrances, Martin Place North, bounded by Hunter Street, Castlereagh Street and Elizabeth Street, and Martin Place South, at Martin Place. New underground pedestrian connections will link the existing Martin Place Station platforms and the metro station platforms.

Martin Place Station was still under construction during Block 1. Construction access and egress to the station was facilitated via Elizabeth Street and Castlereagh Street.

Bus services are available within approximately 150 metres of Martin Place Station, located at Elizabeth Street and Castlereagh Street. New bicycle parking racks will be provided on Castlereagh Street at both station entries, and the existing taxi ranks close to the station will be retained.

The Martin Place Station study area consists of six intersections. **Table 5-44** presents the peak hours utilised for modelling the intersections. **Table 5-45** provides a summary of the intersection level of service while

Figure 5-40 visualises a geospatial summary of the intersection level of service within the Martin Place Station study area.

**Table 5-44 Block 1 – Martin Place Station peak hours modelled**

| Network ID | Intersection ID | Weekday AM peak hour |            | Weekday PM peak hour |            | Weekend peak hour |            |
|------------|-----------------|----------------------|------------|----------------------|------------|-------------------|------------|
|            |                 | Day                  | Start time | Day                  | Start time | Day               | Start time |
| MPL-N1     | MPL01           | Wednesday            | 9.00am     | Wednesday            | 5.30pm     | Saturday          | 12.15pm    |
|            | MPL02           |                      |            |                      |            |                   |            |
|            | MPL03           |                      |            |                      |            |                   |            |
|            | MPL04           |                      |            |                      |            |                   |            |
| -          | MPL05           | Tuesday              | 9.00am     | Friday               | 6.00pm     | Saturday          | 1.30pm     |
| -          | MPL06           | Wednesday            | 8.45am     | Wednesday            | 5.15pm     | Saturday          | 12.15pm    |

**Table 5-45 Block 1 – Martin Place Station intersection performance summary**

| Intersection ID | Intersection   | Level of service (LOS) |                 |              |
|-----------------|--|------------------------|-----------------|--------------|
|                 |  | Weekday AM Peak        | Weekday PM Peak | Weekend Peak |
| MPL01           | Hunter Street / Castlereagh Street / Bligh Street (Signal)                     | LOS B                  | LOS B           | LOS B        |
| MPL02           | Hunter Street / Elizabeth Street / Chifley Square (Signal)                     | LOS C                  | LOS C           | LOS B        |
| MPL03           | Bent Street / Bligh Street (Signal)  | LOS A                  | LOS A           | LOS A        |
| MPL04           | Bent Street / Phillip Street (Signal)  | LOS C                  | LOS B           | LOS B        |
| MPL05           | Pedestrian Mid-block Crossing at Castlereagh Street (Pedestrian only – Signal) | LOS B                  | LOS A           | LOS A        |

| Intersection ID | Intersection   | Level of service (LOS) |                 |              |
|-----------------|--|------------------------|-----------------|--------------|
|                 |  | Weekday AM Peak        | Weekday PM Peak | Weekend Peak |
| MPL06           | Pedestrian Mid-block Crossing at Elizabeth Street (Pedestrian only – Signal) | LOS A                  | LOS A           | LOS B        |

Overall, in the Martin Place Station study area, the intersection performance during the peak periods is satisfactory, operating at LOS C or better.



Figure 5-40 Block 1 – Martin Place Station geospatial intersection performance summary



**5.5.1 MPL01 – Hunter Street / Castlereagh Street / Bligh Street**

The signalised intersection, composed of Hunter Street, Castlereagh Street and Bligh Street, is located directly north-west of Martin Place North. It connects the local roads of Bligh Street and Hunter Street in the Sydney CBD with Castlereagh Street, a major local road running through the Sydney CBD.

**Figure 5-41** illustrates both the general intersection layout as modelled in SIDRA Intersection and the layout as per aerial imagery.

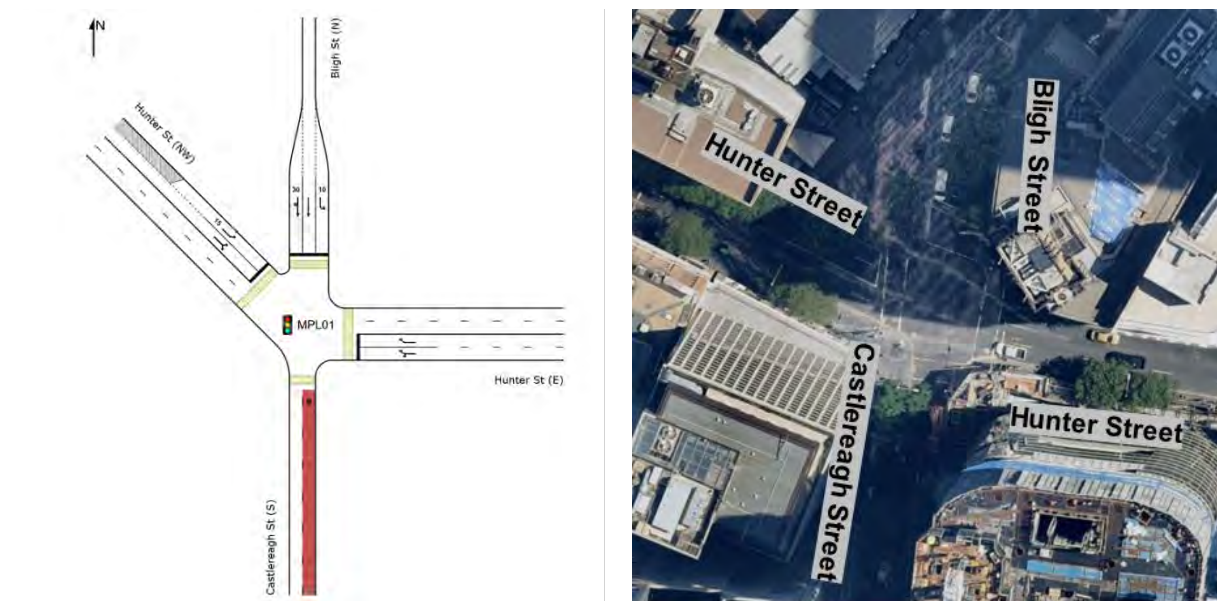

Source: Nearmap, accessed on 24 March 2023

**Figure 5-41** Block 1 - SIDRA Intersection layout (left) and Nearmap aerial imagery (right) of MPL01

**Table 5-46** presents a performance summary of this intersection.

**Table 5-46** Block 1 - Intersection performance summary of MPL01

| Intersection   | Peak       | Approach     | Degree of saturation | Average delay (seconds) | 95 <sup>th</sup> percentile queue (metres) | Level of service (LOS) |
|--|------------|--------------|----------------------|-------------------------|--|------------------------|
| Hunter Street / Castlereagh Street / Bligh Street (Signal) | Weekday AM | East         | 0.421                | 20.2                    | 65.3                                       | LOS B                  |
|  |            | North        | 0.421                | 38.6                    | 26.9                                       | LOS C                  |
|  |            | North-west   | 0.288                | 14.1                    | 31.2                                       | LOS A                  |
|  |            | <b>Total</b> | <b>0.421</b>         | <b>21.4</b>             | <b>65.3</b>                                | <b>LOS B</b>           |
|  | Weekday PM | East         | 0.319                | 16.2                    | 46.3                                       | LOS B                  |
|  |            | North        | 0.665                | 49.4                    | 33.3                                       | LOS D                  |
|  |            | North-west   | 0.396                | 11.6                    | 43.3                                       | LOS A                  |
|  |            | <b>Total</b> | <b>0.665</b>         | <b>21.3</b>             | <b>46.3</b>                                | <b>LOS B</b>           |
|  | Weekend    | East         | 0.258                | 13.9                    | 24.3                                       | LOS A                  |
|  |            | North        | 0.263                | 26.6                    | 14.5                                       | LOS B                  |
|  |            | North-west   | 0.127                | 9.8                     | 14.0                                       | LOS A                  |
|  |            | <b>Total</b> | <b>0.263</b>         | <b>14.6</b>             | <b>24.3</b>                                | <b>LOS B</b>           |

Overall, the intersection of Hunter Street, Castlereagh Street and Bligh Street performs satisfactorily at LOS B. The 95<sup>th</sup> percentile queue on Hunter Street (east approach) extends back to Elizabeth Street during the weekday AM and PM peak hours.

**5.5.2 MPL02 – Hunter Street / Elizabeth Street / Chifley Square**

The signalised intersection, composed of Hunter Street, Elizabeth Street and Chifley Square, is located directly north-east of Martin Place North. It connects the local roads of Chifley Square and Hunter Street in the Sydney CBD with Elizabeth Street, a major local road linking the Sydney CBD and Waterloo.

**Figure 5-42** illustrates both the general intersection layout as modelled in SIDRA Intersection and the layout as per aerial imagery.

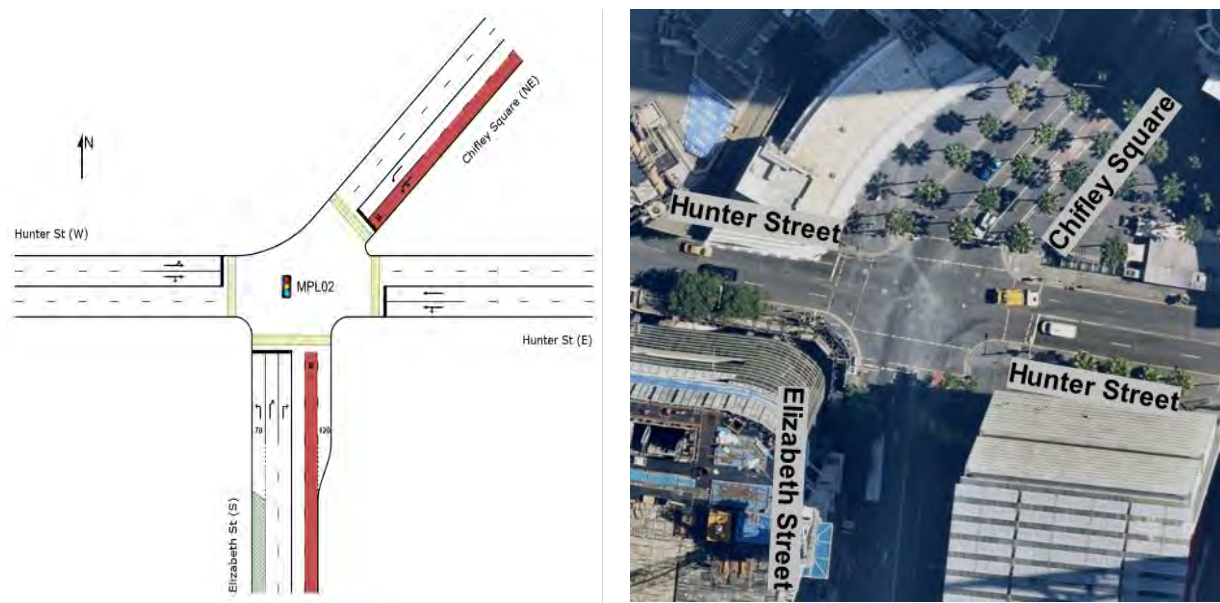

Source: Nearmap, accessed on 24 March 2023

**Figure 5-42 Block 1 - SIDRA Intersection layout (left) and Nearmap aerial imagery (right) of MPL02**

**Table 5-47** presents a performance summary of this intersection.

**Table 5-47 Block 1 - Intersection performance summary of MPL02**

| Intersection   | Peak       | Approach     | Degree of saturation | Average delay (seconds) | 95 <sup>th</sup> percentile queue (metres) | Level of service (LOS) |
|--|------------|--------------|----------------------|-------------------------|--|------------------------|
| Hunter Street / Elizabeth Street / Chifley Square (Signal) | Weekday AM | South        | 0.935                | 45.6                    | 271.0                                      | LOS D                  |
|  |            | East         | 0.533                | 29.8                    | 41.6                                       | LOS C                  |
|  |            | North-east   | 0.443                | 31.4                    | 61.9                                       | LOS C                  |
|  |            | West         | 0.430                | 33.0                    | 62.6                                       | LOS C                  |
|  |            | <b>Total</b> | <b>0.935</b>         | <b>38.7</b>             | <b>271.0</b>                               | <b>LOS C</b>           |
|  | Weekday PM | South        | 0.909                | 43.2                    | 259.0                                      | LOS D                  |
|  |            | East         | 0.391                | 28.7                    | 38.3                                       | LOS C                  |
|  |            | North-east   | 0.481                | 33.9                    | 65.3                                       | LOS C                  |
|  |            | West         | 0.504                | 31.9                    | 65.3                                       | LOS C                  |
|  |            | <b>Total</b> | <b>0.909</b>         | <b>37.0</b>             | <b>259.0</b>                               | <b>LOS C</b>           |
| Weekend  | South      | 0.679        | 18.9                 | 95.8                    | LOS B                                      |                        |

| Intersection | Peak | Approach     | Degree of saturation | Average delay (seconds) | 95 <sup>th</sup> percentile queue (metres) | Level of service (LOS) |
|--------------|------|--------------|----------------------|-------------------------|--|------------------------|
|              |      | East         | 0.247                | 16.9                    | 18.3                                       | LOS B                  |
|              |      | North-east   | 0.293                | 26.4                    | 24.5                                       | LOS B                  |
|              |      | West         | 0.212                | 17.5                    | 26.0                                       | LOS B                  |
|              |      | <b>Total</b> | <b>0.679</b>         | <b>19.1</b>             | <b>95.8</b>                                | <b>LOS B</b>           |

Overall, the intersection of Hunter Street, Elizabeth Street and Chifley Square performs satisfactorily at LOS C or better. The 95<sup>th</sup> percentile queues on Elizabeth Street (south approach) extend back to the mid-block crossing on Elizabeth Street (MPL06) during the weekday AM and PM peak hours. Similarly, the 95<sup>th</sup> percentile queues on Hunter Street (west approach) extend back to Castlereagh Street during the weekday AM and PM peak hours.

**5.5.3 MPL03 – Bent Street / Bligh Street**

The signalised intersection, composed of Bent Street and Bligh Street, is located north of Martin Place North. It connects the local roads of Bent Street and Bligh Street in the Sydney CBD, providing access to the major local road of Castlereagh Street further south.

Figure 5-43 illustrates both the general intersection layout as modelled in SIDRA Intersection and the layout as per aerial imagery.

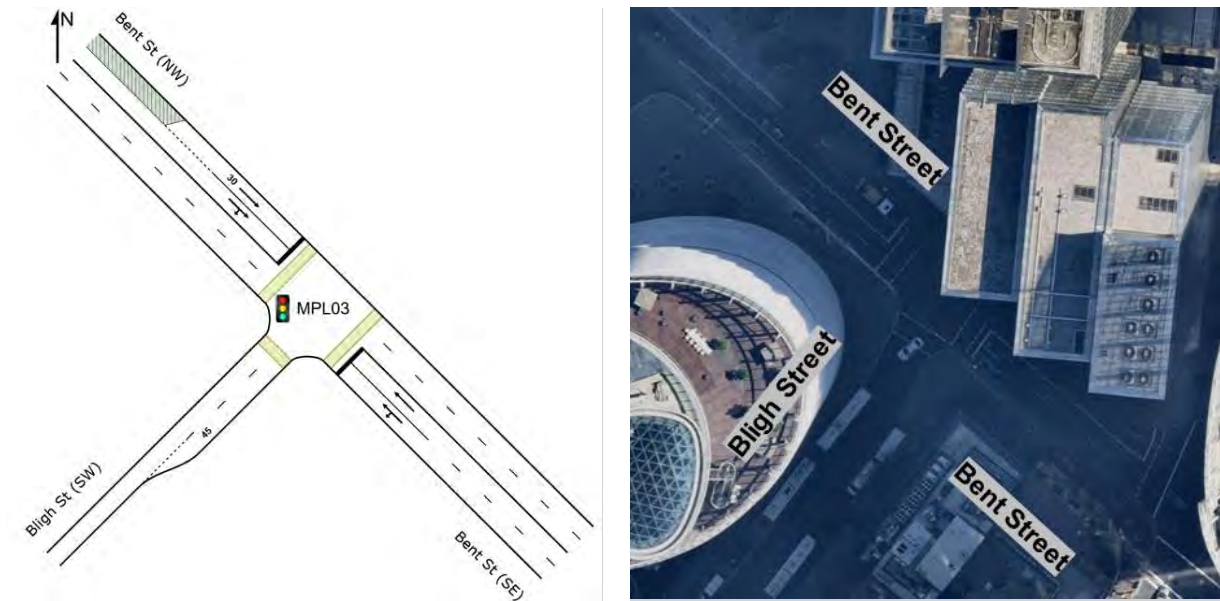

Source: Nearmap, accessed on 24 March 2023

Figure 5-43 Block 1 - SIDRA Intersection layout (left) and Nearmap aerial imagery (right) of MPL03

Table 5-48 presents a performance summary of this intersection.

Table 5-48 Block 1 - Intersection performance summary of MPL03

| Intersection | Peak       | Approach   | Degree of saturation | Average delay (seconds) | 95 <sup>th</sup> percentile queue (metres) | Level of service (LOS) |
|--------------|------------|------------|----------------------|-------------------------|--|------------------------|
|              | Weekday AM | South-east | 0.273                | 3.8                     | 33.9                                       | LOS A                  |
|              |            | North-west | 0.175                | 4.7                     | 9.2  | LOS A                  |

| Intersection                               | Peak       | Approach     | Degree of saturation | Average delay (seconds) | 95 <sup>th</sup> percentile queue (metres) | Level of service (LOS) |
|--|------------|--------------|----------------------|-------------------------|--|------------------------|
| Bent Street / Bligh Street<br><br>(Signal) | Weekday PM | <b>Total</b> | <b>0.273</b>         | <b>4.0</b>              | <b>33.9</b>                                | <b>LOS A</b>           |
|  |            | South-east   | 0.239                | 4.1                     | 23.3                                       | LOS A                  |
|  |            | North-west   | 0.152                | 4.3                     | 15.5                                       | LOS A                  |
|  | Weekend    | <b>Total</b> | <b>0.239</b>         | <b>4.2</b>              | <b>23.3</b>                                | <b>LOS A</b>           |
|  |            | South-east   | 0.390                | 3.8                     | 22.6                                       | LOS A                  |
|  |            | North-west   | 0.098                | 4.4                     | 9.5  | LOS A                  |
|  |            | <b>Total</b> | <b>0.390</b>         | <b>4.0</b>              | <b>22.6</b>                                | <b>LOS A</b>           |

Overall, the intersection of Bent Street and Bligh Street performs satisfactorily at LOS A. The 95<sup>th</sup> percentile queue lengths are accommodated within the approach distances for all approaches.

**5.5.4 MPL04 – Bent Street / Phillip Street**

The signalised intersection, composed of Bent Street and Phillip Street, is located north of Martin Place North. It connects the local roads of Bent Street and Phillip Street in the Sydney CBD, providing access to the major local road of Elizabeth Street further south.

Figure 5-44 illustrates both the general intersection layout as modelled in SIDRA Intersection and the layout as per aerial imagery.

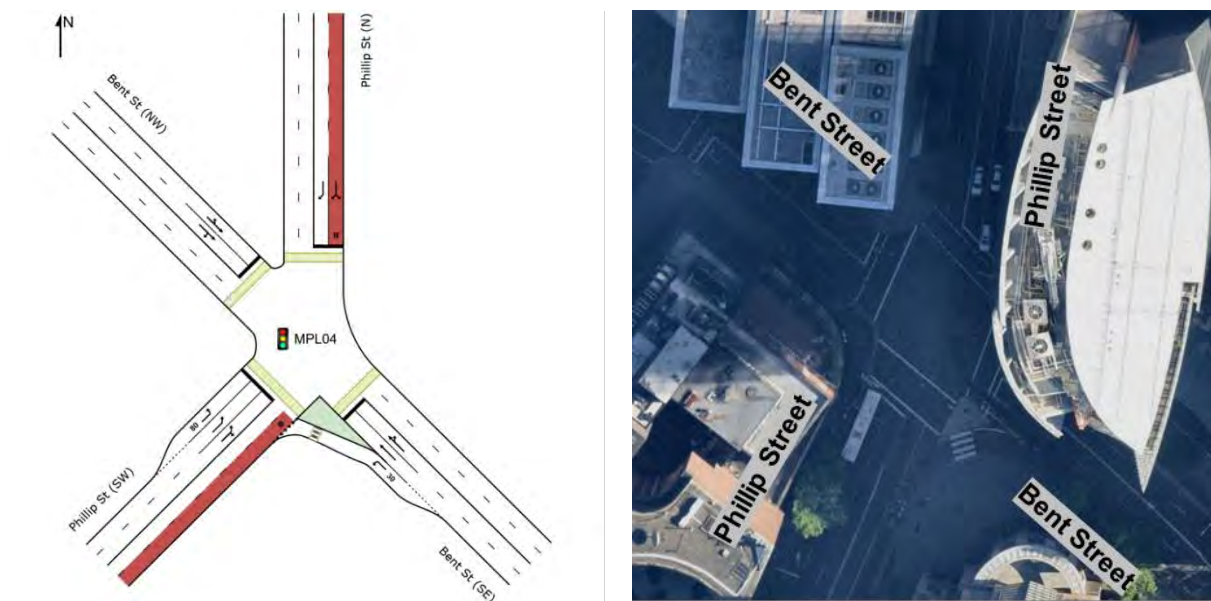

Source: Nearmap, accessed on 24 March 2023

Figure 5-44 Block 1 - SIDRA Intersection layout (left) and Nearmap aerial imagery (right) of MPL04

Table 5-49 presents a performance summary of this intersection.



Table 5-49 Block 1 - Intersection performance summary of MPL04

| Intersection                             | Peak       | Approach     | Degree of saturation | Average delay (seconds) | 95 <sup>th</sup> percentile queue (metres) | Level of service (LOS) |
|--|------------|--------------|----------------------|-------------------------|--|------------------------|
| Bent Street / Phillip Street<br>(Signal) | Weekday AM | South-east   | 0.984                | 75.9                    | 149.1                                      | LOS F                  |
|  |            | North        | 0.167                | 11.2                    | 25.5                                       | LOS A                  |
|  |            | North-west   | 0.240                | 33.0                    | 15.6                                       | LOS C                  |
|  |            | South-west   | 0.277                | 10.7                    | 45.9                                       | LOS A                  |
|  |            | <b>Total</b> | <b>0.984</b>         | <b>34.0</b>             | <b>149.1</b>                               | <b>LOS C</b>           |
|  | Weekday PM | South-east   | 0.747                | 41.8                    | 67.5                                       | LOS C                  |
|  |            | North        | 0.196                | 12.3                    | 30.6                                       | LOS A                  |
|  |            | North-west   | 0.489                | 35.6                    | 29.7                                       | LOS C                  |
|  |            | South-west   | 0.438                | 11.7                    | 52.2                                       | LOS A                  |
|  |            | <b>Total</b> | <b>0.747</b>         | <b>21.4</b>             | <b>67.5</b>                                | <b>LOS B</b>           |
|  | Weekend    | South-east   | 0.790                | 27.8                    | 71.7                                       | LOS B                  |
|  |            | North        | 0.104                | 11.7                    | 11.2                                       | LOS A                  |
|  |            | North-west   | 0.229                | 21.4                    | 15.6                                       | LOS B                  |
|  |            | South-west   | 0.238                | 12.8                    | 37.4                                       | LOS A                  |
|  |            | <b>Total</b> | <b>0.790</b>         | <b>18.4</b>             | <b>71.7</b>                                | <b>LOS B</b>           |

Overall, the intersection of Bent Street and Phillip Street performs satisfactorily at LOS C or better. The 95<sup>th</sup> percentile queue on Bent Street (south-east approach) extends back to Macquarie Street during the weekday AM peak hour.

#### 5.5.5 MPL05 – Pedestrian Mid-block Crossing at Castlereagh Street

The signalised pedestrian mid-block crossing at Castlereagh Street is located directly north-west of Martin Place South. It offers a signalised pedestrian crossing over Castlereagh Street, a major local road that runs through the Sydney CBD.

During Block 1, the east kerbside lane was closed during all during all peak periods due to Sydney Metro construction. This closure extended to the middle departure lane during the weekend peak period.

**Figure 5-45** illustrates both the general intersection layout as modelled in SIDRA Intersection and the layout as per aerial imagery.

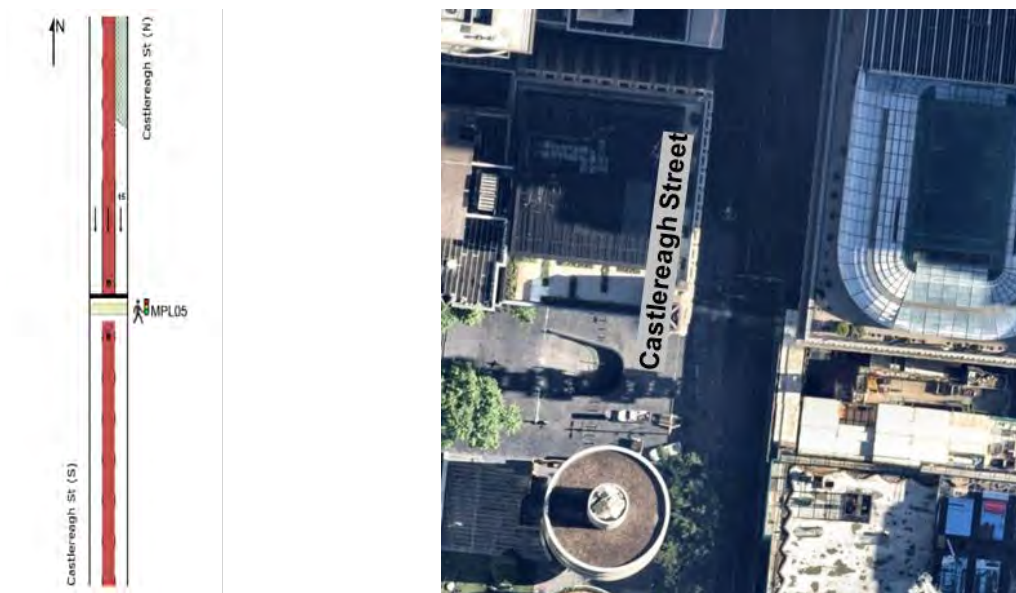

Source: Nearmap, accessed on 24 March 2023

Figure 5-45 Block 1 - SIDRA Intersection layout (left) and Nearmap aerial imagery (right) of MPL05

Table 5-50 presents a performance summary of this intersection.

Table 5-50 Block 1 - Intersection performance summary of MPL05

| Intersection  | Peak       | Approach     | Degree of saturation | Average delay (seconds) | 95 <sup>th</sup> percentile queue (metres) | Level of service (LOS) |
|---|------------|--------------|----------------------|-------------------------|--|------------------------|
| Pedestrian Mid-block Crossing at Castlereagh Street<br><br>(Pedestrian only – Signal) | Weekday AM | North        | 0.699                | 14.6                    | 75.8                                       | LOS B                  |
|   |            | <b>Total</b> | <b>0.699</b>         | <b>14.6</b>             | <b>75.8</b>                                | <b>LOS B</b>           |
|   | Weekday PM | North        | 0.557                | 12.3                    | 49.0                                       | LOS A                  |
|   |            | <b>Total</b> | <b>0.557</b>         | <b>12.3</b>             | <b>49.0</b>                                | <b>LOS A</b>           |
|   | Weekend    | North        | 0.211                | 6.4                     | 20.1                                       | LOS A                  |
|   |            | <b>Total</b> | <b>0.211</b>         | <b>6.4</b>              | <b>20.1</b>                                | <b>LOS A</b>           |

Overall, the pedestrian mid-block crossing at Castlereagh Street performs satisfactorily at LOS B or better. The 95<sup>th</sup> percentile queue lengths are accommodated within the approach distances for all approaches.

**5.5.6 MPL06 – Pedestrian Mid-block Crossing at Elizabeth Street**

The signalised pedestrian mid-block crossing at Elizabeth Street is located directly north-east of Martin Place South. It offers a signalised pedestrian crossing over Elizabeth Street, a major local road linking the Sydney CBD and Waterloo.

Figure 5-46 illustrates both the general intersection layout as modelled in SIDRA Intersection and the layout as per aerial imagery.

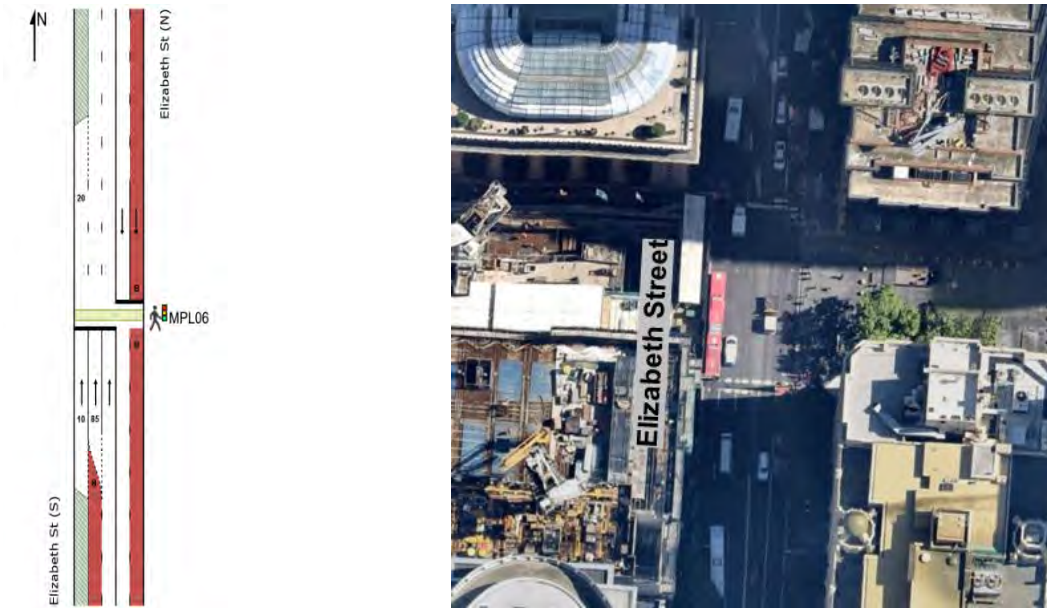

Source: Nearmap, accessed on 24 March 2023

Figure 5-46 Block 1 - SIDRA Intersection layout (left) and Nearmap aerial imagery (right) of MPL06

Table 5-51 presents a performance summary of this intersection.

Table 5-51 Block 1 - Intersection performance summary of MPL06

| Intersection  | Peak       | Approach     | Degree of saturation | Average delay (seconds) | 95 <sup>th</sup> percentile queue (metres) | Level of service (LOS) |
|---|------------|--------------|----------------------|-------------------------|--|------------------------|
| Pedestrian Mid-block Crossing at Elizabeth Street<br><br>(Pedestrian only – Signal) | Weekday AM | South        | 0.542                | 11.6                    | 90.6                                       | LOS A                  |
|   |            | North        | 0.340                | 9.3                     | 49.2                                       | LOS A                  |
|   |            | <b>Total</b> | <b>0.542</b>         | <b>12.9</b>             | <b>90.6</b>                                | <b>LOS A</b>           |
|   | Weekday PM | South        | 0.434                | 8.8                     | 81.6                                       | LOS A                  |
|   |            | North        | 0.310                | 7.3                     | 52.7                                       | LOS A                  |
|   |            | <b>Total</b> | <b>0.434</b>         | <b>9.8</b>              | <b>81.6</b>                                | <b>LOS A</b>           |
|   | Weekend    | South        | 0.672                | 17.5                    | 55.4                                       | LOS B                  |
|   |            | North        | 0.389                | 14.3                    | 28.0                                       | LOS A                  |
|   |            | <b>Total</b> | <b>0.672</b>         | <b>18.9</b>             | <b>55.4</b>                                | <b>LOS B</b>           |

Overall, the pedestrian mid-block crossing at Elizabeth Street performs satisfactorily at LOS B or better. The 95<sup>th</sup> percentile queue lengths are accommodated within the approach distances for all approaches.

## 5.6 Pitt Street Station

Pitt Street Station is a new underground station and the sixth stop on the City & Southwest Line (towards Sydenham). It is located at the junction of Sydney's southern CBD and the midtown retail precinct. Pitt Street Station will have station entrances within two new pedestrian plazas, Pitt Street North, bounded by Pitt Street, Park Street and Castlereagh Street, and Pitt Street South, at the corner of Pitt Street and Bathurst Street.

Pitt Street Station was still under construction during Block 1. Construction access to Pitt Street North was facilitated via Park Street whereas access to Pitt Street South was facilitated via Bathurst Street.

Several bus routes operate within the vicinity of the new Pitt Street Station. Bus services are available within approximately 100 metres of Pitt Street Station, located at Elizabeth Street and Park Street. The CBD and South-East Light Rail (CSELR) project which is currently operational along George Street.

To accommodate future pedestrian demand, footpath widening is planned for Bathurst Street, immediately outside the future Pitt Street South. New bicycle parking racks will be provided on Park Street and Bathurst Street.

The Pitt Street Station study area consists of four intersections. **Table 5-52** presents the peak hours utilised for modelling the intersections. **Table 5-53** provides a summary of the intersection level of service while

Figure 5-47 visualises a geospatial summary of the intersection level of service within the Pitt Street Station study area.

**Table 5-52 Block 1 - Pitt Street Station peak hours modelled**

| Network ID | Intersection ID | Weekday AM peak hour |            | Weekday PM peak hour |            | Weekend peak hour |            |
|------------|-----------------|----------------------|------------|----------------------|------------|-------------------|------------|
|            |                 | Day                  | Start time | Day                  | Start time | Day               | Start time |
| PIT-N1     | PIT01           | Tuesday              | 9.15am     | Thursday             | 4.45pm     | Saturday          | 12.15pm    |
|            | PIT02           |                      |            |                      |            |                   |            |
|            | PIT03           |                      |            |                      |            |                   |            |
|            | PIT04           |                      |            |                      |            |                   |            |

**Table 5-53 Block 1 - Pitt Street Station intersection performance summary**

| Intersection ID | Intersection                                  | Level of service (LOS) |                 |              |
|-----------------|---|------------------------|-----------------|--------------|
|                 |   | Weekday AM Peak        | Weekday PM Peak | Weekend Peak |
| PIT01           | Pitt Street / Bathurst Street (Signal)        | LOS A                  | LOS B           | LOS A        |
| PIT02           | Castlereagh Street / Bathurst Street (Signal) | LOS A                  | LOS A           | LOS A        |
| PIT03           | Park Street / Castlereagh Street (Signal)     | LOS B                  | LOS B           | LOS B        |
| PIT04           | Park Street / Pitt Street (Signal)            | LOS B                  | LOS B           | LOS B        |

Overall, in the Pitt Street Station study area, the intersection performance during the peak periods is satisfactory, operating at LOS B or better.





Figure 5-47 Block 1 – Pitt Street Station geospatial intersection performance summary

**5.6.1 PIT01 – Pitt Street / Bathurst Street**

The signalised intersection, composed of Pitt Street and Bathurst Street, is located directly north-west of Pitt Street South. It connects the major local road of Pitt Street and major regional road of Bathurst Street running through the inner Sydney CBD.

During Block 1, the available storage on the right turn kerbside lane on Pitt Street (south approach) was reduced due to the presence of a Sydney Metro construction work zone.

**Figure 5-48** illustrates both the general intersection layout as modelled in SIDRA Intersection and the layout as per aerial imagery.



Source: Nemap, accessed on 24 March 2023

**Figure 5-48** Block 1 - SIDRA Intersection layout (left) and Nemap aerial imagery (right) of PIT01

**Table 5-54** presents a performance summary of this intersection.

**Table 5-54** Block 1 - Intersection performance summary of PIT01

| Intersection                           | Peak       | Approach     | Degree of saturation | Average delay (seconds) | 95 <sup>th</sup> percentile queue (metres) | Level of service (LOS) |
|--|------------|--------------|----------------------|-------------------------|--|------------------------|
| Pitt Street / Bathurst Street (Signal) | Weekday AM | South        | 0.369                | 20.0                    | 21.5                                       | LOS B                  |
|  |            | West         | 0.374                | 9.9                     | 35.7                                       | LOS A                  |
|  |            | <b>Total</b> | <b>0.374</b>         | <b>12.4</b>             | <b>35.7</b>                                | <b>LOS A</b>           |
|  | Weekday PM | South        | 0.690                | 50.9                    | 54.3                                       | LOS D                  |
|  |            | West         | 0.347                | 10.7                    | 61.4                                       | LOS A                  |
|  |            | <b>Total</b> | <b>0.690</b>         | <b>21.0</b>             | <b>61.4</b>                                | <b>LOS B</b>           |
|  | Weekend    | South        | 0.391                | 18.1                    | 16.7                                       | LOS B                  |
|  |            | West         | 0.381                | 9.2                     | 35.8                                       | LOS A                  |
|  |            | <b>Total</b> | <b>0.391</b>         | <b>11.1</b>             | <b>35.8</b>                                | <b>LOS A</b>           |

Overall, the intersection of Pitt Street and Bathurst Street performs satisfactorily at LOS B or better. The 95th percentile queue lengths are accommodated within the approach distances for all approaches.

**5.6.2 PIT02 – Castlereagh Street / Bathurst Street**

The signalised intersection, composed of Castlereagh Street and Bathurst Street, is located north-east of Pitt Street South. It connects the major local road of Castlereagh Street and major regional road of Bathurst Street running through the inner Sydney CBD.

**Figure 5-49** illustrates both the general intersection layout as modelled in SIDRA Intersection and the layout as per aerial imagery.



Source: Nearmap, accessed on 24 March 2023

**Figure 5-49 Block 1 - SIDRA Intersection layout (left) and Nearmap aerial imagery (right) of PIT02**

**Table 5-55** presents a performance summary of this intersection.

**Table 5-55 Block 1 - Intersection performance summary of PIT02**

| Intersection   | Peak       | Approach     | Degree of saturation | Average delay (seconds) | 95 <sup>th</sup> percentile queue (metres) | Level of service (LOS) |
|--|------------|--------------|----------------------|-------------------------|--|------------------------|
| Castlereagh Street / Bathurst Street<br><br>(Signal) | Weekday AM | North        | 0.326                | 18.3                    | 20.1                                       | LOS B                  |
|  |            | West         | 0.319                | 4.9                     | 23.1                                       | LOS A                  |
|  |            | <b>Total</b> | <b>0.326</b>         | <b>8.2</b>              | <b>23.1</b>                                | <b>LOS A</b>           |
|  | Weekday PM | North        | 0.441                | 32.8                    | 59.0                                       | LOS C                  |
|  |            | West         | 0.292                | 5.0                     | 41.8                                       | LOS A                  |
|  |            | <b>Total</b> | <b>0.441</b>         | <b>11.9</b>             | <b>59.0</b>                                | <b>LOS A</b>           |
|  | Weekend    | North        | 0.162                | 14.2                    | 10.3                                       | LOS A                  |
|  |            | West         | 0.382                | 4.5                     | 22.5                                       | LOS A                  |
|  |            | <b>Total</b> | <b>0.382</b>         | <b>6.1</b>              | <b>22.5</b>                                | <b>LOS A</b>           |

Overall, the intersection of Castlereagh Street and Bathurst Street performs satisfactorily at LOS A. The 95<sup>th</sup> percentile queue lengths are accommodated within the approach distances for all approaches.



### 5.6.3 PIT03 – Park Street / Castlereagh Street

The signalised intersection, composed of Park Street and Castlereagh Street, is located directly south-east of Pitt Street North. It connects the major regional road of Park Street and major local road of Castlereagh Street running through the inner Sydney CBD.

During Block 1, the kerbside lane of Park Street (west approach) was blocked upstream at the intersection of Park Street and Pitt Street (PIT04) during the weekend peak.

**Figure 5-50** illustrates both the general intersection layout as modelled in SIDRA Intersection and the layout as per aerial imagery.

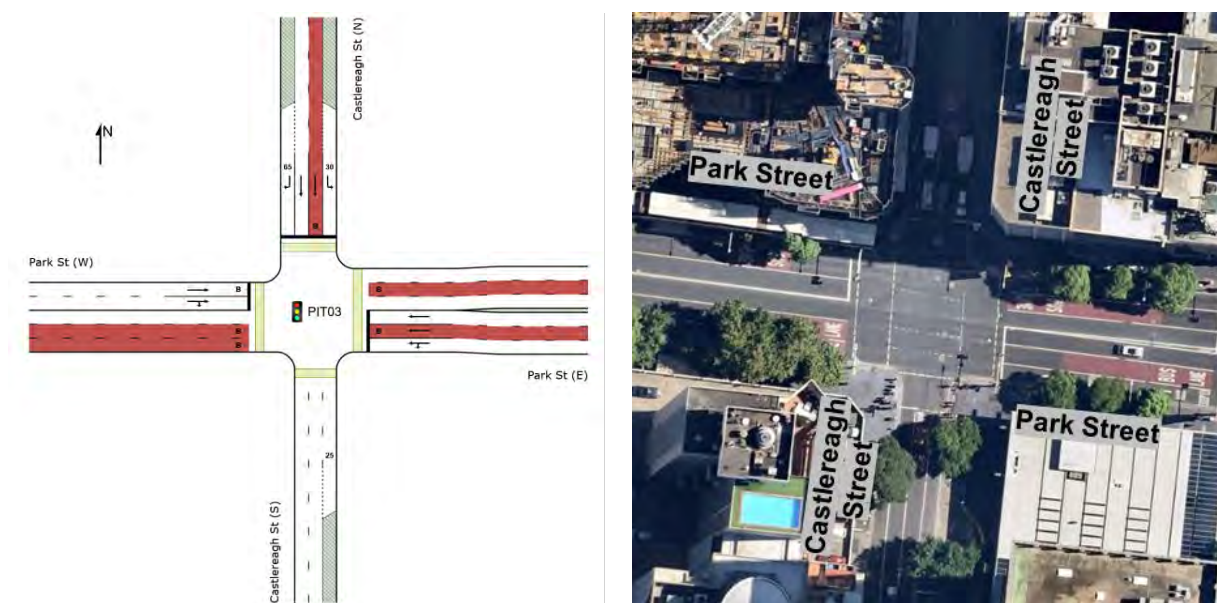

Source: Nearmap, accessed on 24 March 2023

**Figure 5-50** Block 1 - SIDRA Intersection layout (left) and Nearmap aerial imagery (right) of PIT03

**Table 5-56** presents a performance summary of this intersection.

**Table 5-56** Block 1 - Intersection performance summary of PIT03

| Intersection                              | Peak       | Approach     | Degree of saturation | Average delay (seconds) | 95 <sup>th</sup> percentile queue (metres) | Level of service (LOS) |
|---|------------|--------------|----------------------|-------------------------|--|------------------------|
| Park Street / Castlereagh Street (Signal) | Weekday AM | East         | 0.349                | 11.8                    | 60.7                                       | LOS A                  |
|   |            | North        | 0.567                | 36.2                    | 68.3                                       | LOS C                  |
|   |            | West         | 0.214                | 12.1                    | 25.2                                       | LOS A                  |
|   |            | <b>Total</b> | <b>0.567</b>         | <b>21.7</b>             | <b>68.3</b>                                | <b>LOS B</b>           |
|   | Weekday PM | East         | 0.349                | 12.5                    | 63.9                                       | LOS A                  |
|   |            | North        | 0.772                | 50.7                    | 67.8                                       | LOS D                  |
|   |            | West         | 0.298                | 13.8                    | 37.8                                       | LOS A                  |
|   |            | <b>Total</b> | <b>0.772</b>         | <b>28.4</b>             | <b>67.8</b>                                | <b>LOS B</b>           |
|   | Weekend    | East         | 0.481                | 10.4                    | 74.9                                       | LOS A                  |
|   |            | North        | 0.507                | 35.9                    | 42.0                                       | LOS C                  |
|   |            | West         | 0.151                | 10.2                    | 16.9                                       | LOS A                  |
|   |            | <b>Total</b> | <b>0.507</b>         | <b>18.9</b>             | <b>74.9</b>                                | <b>LOS B</b>           |



Overall, the intersection of Park Street and Castlereagh Street performs satisfactorily at LOS B. The 95<sup>th</sup> percentile queues on Park Street (east approach) extend back to Elizabeth Street during all peak hours.

**5.6.4 PIT04 – Park Street / Pitt Street**

The signalised intersection, composed of Park Street and Pitt Street, is located directly south-west of Pitt Street North. It connects the major regional road of Park Street and major local road of Pitt Street running through the inner Sydney CBD.

During Block 1, the kerbside departure lane of Park Street (east approach) was blocked towards Castlereagh Street during the weekend peak.

Figure 5-51 illustrates both the general intersection layout as modelled in SIDRA Intersection and the layout as per aerial imagery.



Source: Nearmap, accessed on 24 March 2023

Figure 5-51 Block 1 - SIDRA Intersection layout (left) and Nearmap aerial imagery (right) of PIT04

Table 5-57 presents a performance summary of this intersection.

Table 5-57 Block 1 - Intersection performance summary of PIT04

| Intersection                       | Peak       | Approach     | Degree of saturation | Average delay (seconds) | 95 <sup>th</sup> percentile queue (metres) | Level of service (LOS) |
|------------------------------------|------------|--------------|----------------------|-------------------------|--|------------------------|
| Park Street / Pitt Street (Signal) | Weekday AM | South        | 0.887                | 31.2                    | 42.6                                       | LOS C                  |
|                                    |            | East         | 0.738                | 15.7                    | 69.9                                       | LOS B                  |
|                                    |            | West         | 0.136                | 10.4                    | 10.2                                       | LOS A                  |
|                                    |            | <b>Total</b> | <b>0.887</b>         | <b>23.0</b>             | <b>69.9</b>                                | <b>LOS B</b>           |
|                                    | Weekday PM | South        | 0.967                | 33.2                    | 42.4                                       | LOS C                  |
|                                    |            | East         | 0.697                | 13.9                    | 63.4                                       | LOS A                  |
|                                    |            | West         | 0.178                | 10.8                    | 13.4                                       | LOS A                  |
|                                    |            | <b>Total</b> | <b>0.967</b>         | <b>22.5</b>             | <b>63.4</b>                                | <b>LOS B</b>           |
|                                    | Weekend    | South        | 0.970                | 33.3                    | 38.2                                       | LOS C                  |

| Intersection | Peak | Approach     | Degree of saturation | Average delay (seconds) | 95 <sup>th</sup> percentile queue (metres) | Level of service (LOS) |
|--------------|------|--------------|----------------------|-------------------------|--|------------------------|
|              |      | East         | 0.788                | 17.4                    | 84.9                                       | LOS B                  |
|              |      | West         | 0.079                | 10.0                    | 5.8  | LOS A                  |
|              |      | <b>Total</b> | <b>0.970</b>         | <b>24.0</b>             | <b>84.9</b>                                | <b>LOS B</b>           |

Overall, the intersection of Park Street and Pitt Street performs satisfactorily at LOS B. The 95th percentile queues on Park Street (east approach) extend back to Castlereagh Street during the weekday AM peak and weekend peak hours.

## 5.7 Central Station

Central Station is an existing station and the seventh stop on the City & Southwest Line (towards Sydenham). It is located at the southern end of the Sydney CBD, directly south of Belmore Park between Pitt Street and Elizabeth Street.

Central Station (metro) was still under construction during Block 1. The metro lines are being built under the existing platforms 13, 14 and 15 in Central Station. In addition to the existing seven entrances, a new eastern entrance is being constructed at Chalmers Street. Construction access and egress to the station was facilitated via Randle Lane.

Bus services are available within approximately 100 metres of Central Station, located at Eddy Avenue, Pitt Street, Lee Street and Elizabeth Street. Dedicated cycle lanes are currently provided along Elizabeth Street and Eddy Avenue near Central Station. Enhancement of pedestrian and cycling infrastructure around the station will be enabled by the Sydney Metro City & Southwest project and further investigated by TfNSW.

The Central Station study area consists of five intersections. During Block 1, one intersection was a new pedestrian mid-block crossing which had not yet been constructed. **Table 5-58** presents the peak hours utilised for modelling the intersections. **Table 5-59** provides a summary of the intersection level of service while

Figure 5-52 visualises a geospatial summary of the intersection level of service within the Central Station study area.

**Table 5-58 Block 1 - Central Station peak hours modelled**

| Network ID | Intersection ID | Weekday AM peak hour |            | Weekday PM peak hour |            | Weekend peak hour |            |
|------------|-----------------|----------------------|------------|----------------------|------------|-------------------|------------|
|            |                 | Day                  | Start time | Day                  | Start time | Day               | Start time |
| CEN-N1     | CEN01           | Wednesday            | 8.15am     | Wednesday            | 5.15pm     | Saturday          | 1.45pm     |
|            | CEN02           |                      |            |                      |            |                   |            |
| CEN-N2     | CEN03           | Thursday             | 8.15am     | Thursday             | 5.30pm     | Saturday          | 12.00pm    |
|            | CEN05           |                      |            |                      |            |                   |            |
| -          | CEN04           | Under construction.  |            |                      |            |                   |            |

**Table 5-59 Block 1 - Central Station intersection performance summary**

| Intersection ID | Intersection  | Level of service (LOS) |                 |              |
|-----------------|---|------------------------|-----------------|--------------|
|                 |   | Weekday AM Peak        | Weekday PM Peak | Weekend Peak |
| CEN01           | Elizabeth Street / Eddy Avenue (Signal)                                     | LOS C                  | LOS B           | LOS B        |
| CEN02           | Elizabeth Street / Foveaux Street (Signal)                                  | LOS B                  | LOS C           | LOS B        |
| CEN03           | Elizabeth Street / Cooper Street (Priority – Give Way)                      | LOS A                  | LOS A           | LOS A        |
| CEN04           | New Pedestrian Mid-block Crossing at Randle Lane (Pedestrian only – Signal) | Under construction     |                 |              |
| CEN05           | Elizabeth Street / Randle Street (Signal)                                   | LOS B                  | LOS A           | LOS B        |

Overall, in the Central Station study area, the intersection performance during the peak periods is satisfactory, operating at LOS C or better.

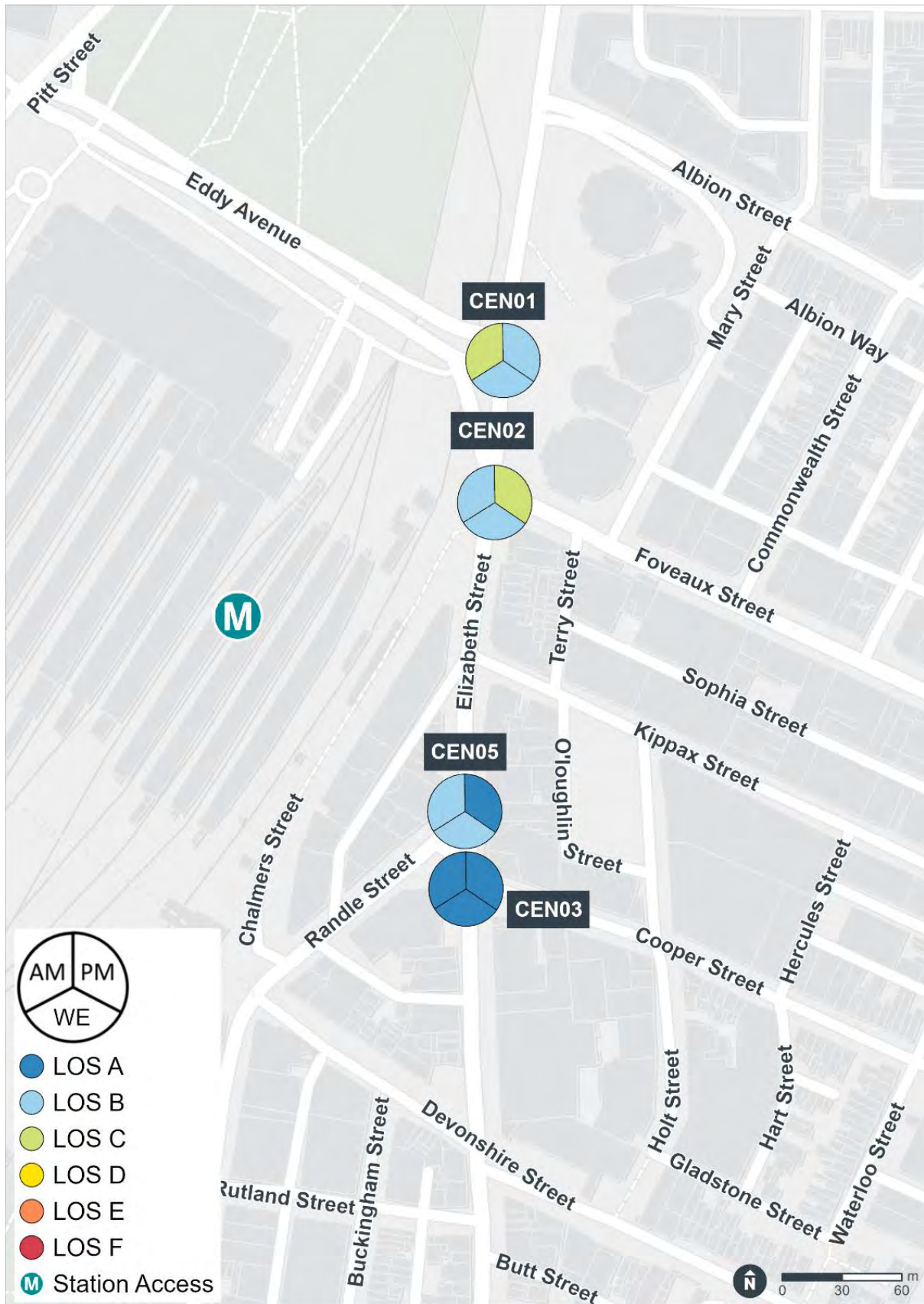

Figure 5-52 Block 1 – Central Station geospatial intersection performance summary



**5.7.1 CEN01 – Elizabeth Street / Eddy Avenue**

The signalised intersection, composed of Elizabeth Street and Eddy Avenue, is located north of Central Station. It connects the regional roads of Eddy Avenue, running through the Sydney CBD, and Elizabeth Street, linking the Sydney CBD and Waterloo. The traffic signals at this intersection are co-ordinated with the intersection of Elizabeth Street and Foveaux Street (CEN02).

**Figure 5-53** illustrates both the general intersection layout as modelled in SIDRA Intersection and the layout as per aerial imagery.

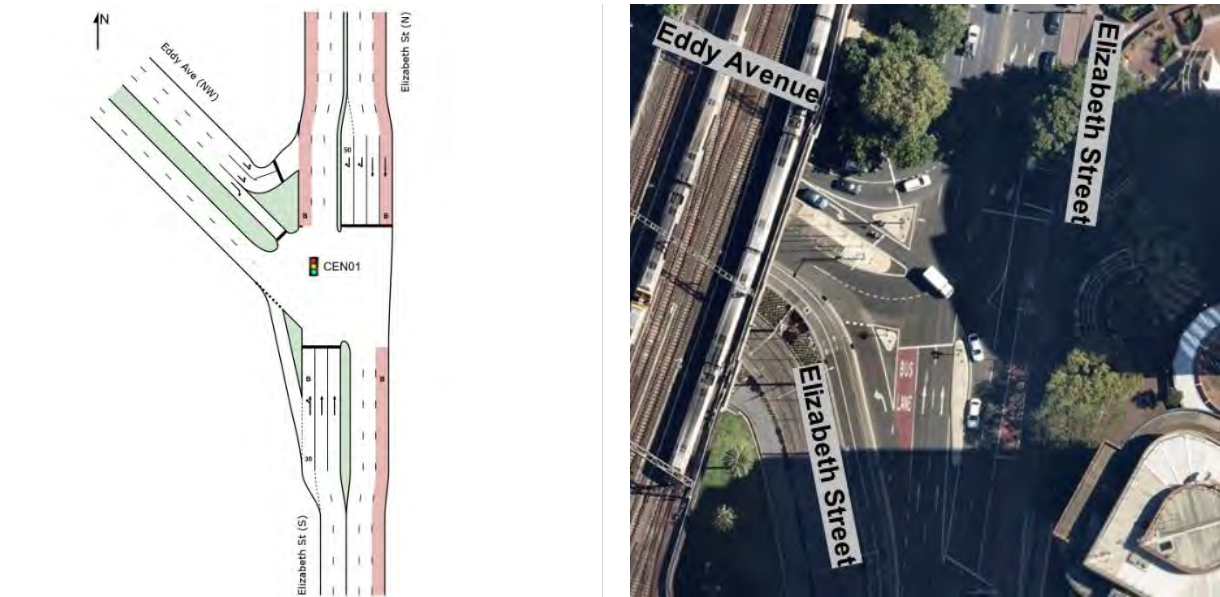

Source: Nearmap, accessed on 24 March 2023

**Figure 5-53 Block 1 - SIDRA Intersection layout (left) and Nearmap aerial imagery (right) of CEN01**

**Table 5-60** presents a performance summary of this intersection.

**Table 5-60 Block 1 - Intersection performance summary of CEN01**

| Intersection                            | Peak       | Approach     | Degree of saturation | Average delay (seconds) | 95 <sup>th</sup> percentile queue (metres) | Level of service (LOS) |
|---|------------|--------------|----------------------|-------------------------|--|------------------------|
| Elizabeth Street / Eddy Avenue (Signal) | Weekday AM | South        | 0.649                | 7.0                     | 57.1                                       | LOS A                  |
|   |            | North        | 0.833                | 43.3                    | 185.7                                      | LOS D                  |
|   |            | North-west   | 0.981                | 71.5                    | 157.2                                      | LOS F                  |
|   |            | <b>Total</b> | <b>0.981</b>         | <b>33.8</b>             | <b>185.7</b>                               | <b>LOS C</b>           |
|   | Weekday PM | South        | 0.548                | 8.4                     | 57.1                                       | LOS A                  |
|   |            | North        | 0.779                | 41.6                    | 207.7                                      | LOS C                  |
|   |            | North-west   | 0.936                | 38.8                    | 100.4                                      | LOS C                  |
|   |            | <b>Total</b> | <b>0.936</b>         | <b>26.7</b>             | <b>207.7</b>                               | <b>LOS B</b>           |
|   | Weekend    | South        | 0.454                | 5.6                     | 45.2                                       | LOS A                  |
|   |            | North        | 0.664                | 38.1                    | 72.3                                       | LOS C                  |
|   |            | North-west   | 0.723                | 35.0                    | 80.8                                       | LOS C                  |
|   |            | <b>Total</b> | <b>0.723</b>         | <b>22.0</b>             | <b>80.8</b>                                | <b>LOS B</b>           |

Overall, the intersection of Elizabeth Street and Eddy Avenue performs satisfactorily at LOS C or better. The 95<sup>th</sup> percentile queues on Elizabeth Street (north approach) extend back to Albion Street during the weekday AM and PM peak hours. Similarly, the 95<sup>th</sup> percentile queues on Eddy Avenue (north-west approach) extend back to the pedestrian mid-block crossing on Eddy Avenue during all peak hours.

**5.7.2 CEN02 – Elizabeth Street / Foveaux Street**

The signalised intersection, composed of Elizabeth Street and Foveaux Street, is located north of Central Station. It connects the regional roads of Foveaux Street, running through Surry Hills, and Elizabeth Street, linking the Sydney CBD and Waterloo. The traffic signals at this intersection are co-ordinated with the intersection of Elizabeth Street and Eddy Avenue (CEN01).

**Figure 5-54** illustrates both the general intersection layout as modelled in SIDRA Intersection and the layout as per aerial imagery.

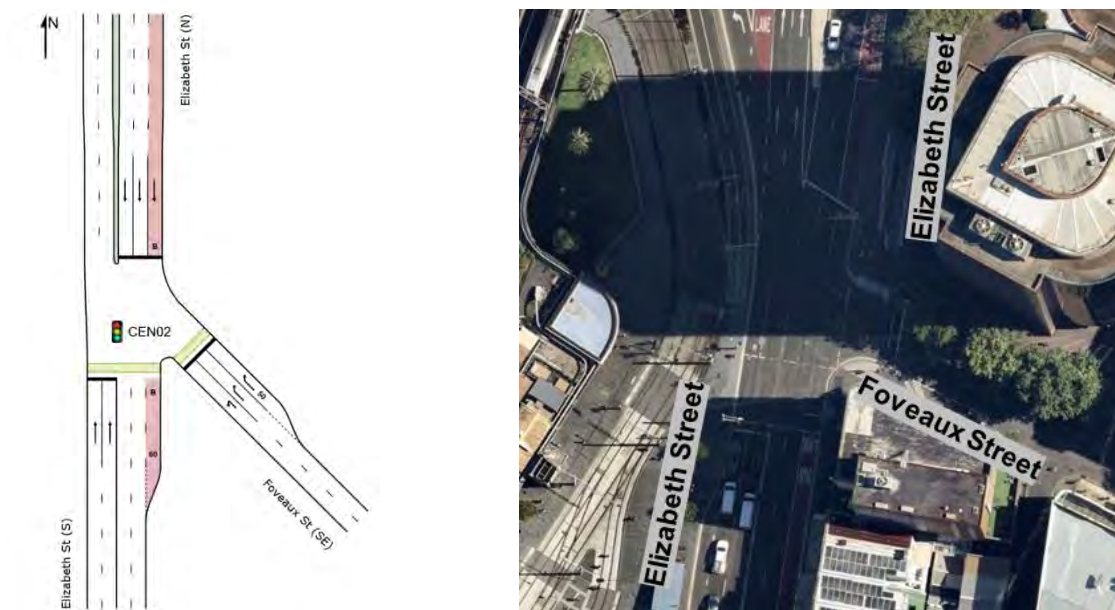

Source: Nearmap, accessed on 24 March 2023

**Figure 5-54 Block 1 - SIDRA Intersection layout (left) and Nearmap aerial imagery (right) of CEN02**

**Table 5-61** presents a performance summary of this intersection.

**Table 5-61 Block 1 - Intersection performance summary of CEN02**

| Intersection                               | Peak       | Approach     | Degree of saturation | Average delay (seconds) | 95 <sup>th</sup> percentile queue (metres) | Level of service (LOS) |
|--|------------|--------------|----------------------|-------------------------|--|------------------------|
| Elizabeth Street / Foveaux Street (Signal) | Weekday AM | South        | 0.716                | 31.5                    | 162.8                                      | LOS C                  |
|  |            | South-east   | 0.608                | 28.2                    | 74.4                                       | LOS B                  |
|  |            | North        | 0.403                | 10.0                    | 57.1                                       | LOS A                  |
|  |            | <b>Total</b> | <b>0.719</b>         | <b>24.4</b>             | <b>162.8</b>                               | <b>LOS B</b>           |
|  | Weekday PM | South        | 0.582                | 33.9                    | 113.1                                      | LOS C                  |
|  |            | South-east   | 0.890                | 46.6                    | 161.1                                      | LOS D                  |
|  |            | North        | 0.529                | 9.6                     | 57.1                                       | LOS A                  |
|  |            | <b>Total</b> | <b>0.890</b>         | <b>30.7</b>             | <b>161.1</b>                               | <b>LOS C</b>           |
|  | Weekend    | South        | 0.647                | 31.8                    | 145.2                                      | LOS C                  |

| Intersection | Peak | Approach     | Degree of saturation | Average delay (seconds) | 95 <sup>th</sup> percentile queue (metres) | Level of service (LOS) |
|--------------|------|--------------|----------------------|-------------------------|--|------------------------|
|              |      | South-east   | 0.408                | 26.3                    | 68.2                                       | LOS B                  |
|              |      | North        | 0.351                | 8.5                     | 57.1                                       | LOS A                  |
|              |      | <b>Total</b> | <b>0.647</b>         | <b>23.4</b>             | <b>145.2</b>                               | <b>LOS B</b>           |

Overall, the intersection of Elizabeth Street and Foveaux Street performs satisfactorily at LOS C or better. The 95<sup>th</sup> percentile queues on Elizabeth Street (south approach) extend back to Randle Street during the weekday AM peak and weekend peak hours. Similarly, the 95<sup>th</sup> percentile queue on Foveaux Street (south-east approach) extends back to Commonwealth Street during the weekday PM peak hour.

### 5.7.3 CEN03 – Elizabeth Street / Cooper Street

The priority intersection, composed of Elizabeth Street and Cooper Street, is located south of Central Station. It connects the local road of Cooper Street with the regional road of Elizabeth Street, linking the Sydney CBD to Waterloo.

Figure 5-55 illustrates both the general intersection layout as modelled in SIDRA Intersection and the layout as per aerial imagery.

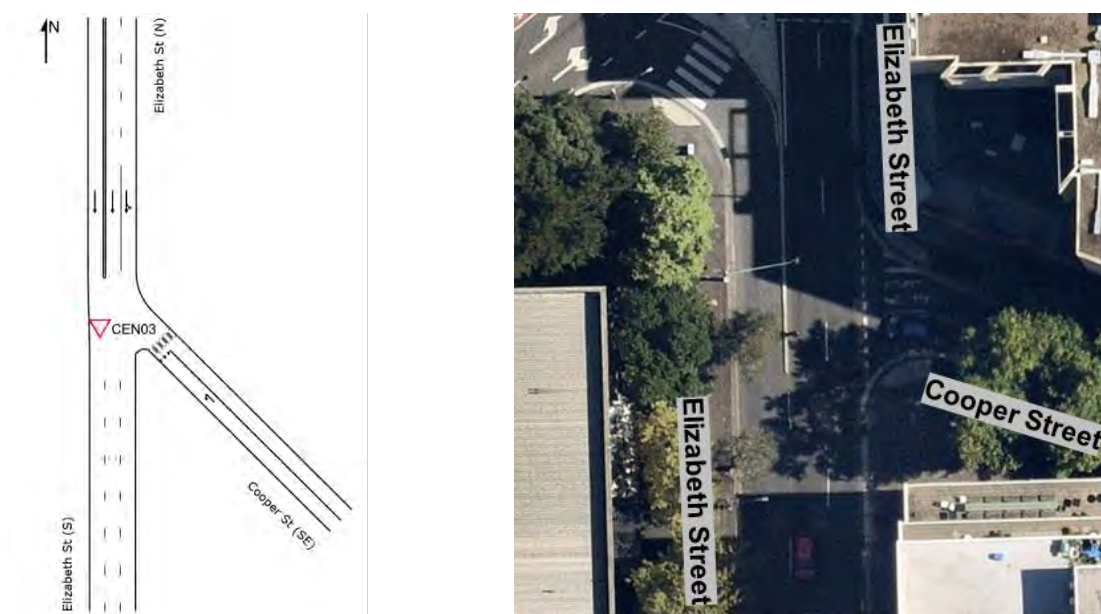

Source: Nearmap, accessed on 24 March 2023

Figure 5-55 Block 1 - SIDRA Intersection layout (left) and Nearmap aerial imagery (right) of CEN03

Table 5-62 presents a performance summary of this intersection.

Table 5-62 Block 1 - Intersection performance summary of CEN03

| Intersection                     | Peak       | Approach     | Degree of saturation | Average delay (seconds) | 95 <sup>th</sup> percentile queue (metres) | Level of service (LOS) |
|----------------------------------|------------|--------------|----------------------|-------------------------|--|------------------------|
| Elizabeth Street / Cooper Street | Weekday AM | South-east   | 0.090                | 6.2                     | 2.7  | LOS A                  |
|                                  |            | North        | 0.156                | 5.0                     | 4.0  | LOS A                  |
|                                  |            | <b>Total</b> | <b>0.090</b>         | <b>6.2</b>              | <b>2.7</b>                                 | <b>LOS A</b>           |

| Intersection          | Peak       | Approach     | Degree of saturation | Average delay (seconds) | 95 <sup>th</sup> percentile queue (metres) | Level of service (LOS) |
|-----------------------|------------|--------------|----------------------|-------------------------|--|------------------------|
| (Priority – Give Way) | Weekday PM | South-east   | 0.101                | 6.6                     | 2.9  | LOS A                  |
|                       |            | North        | 0.199                | 5.4                     | 4.5  | LOS A                  |
|                       |            | <b>Total</b> | <b>0.101</b>         | <b>6.6</b>              | <b>2.9</b>                                 | <b>LOS A</b>           |
|                       | Weekend    | South-east   | 0.062                | 5.7                     | 1.8  | LOS A                  |
|                       |            | North        | 0.186                | 3.2                     | 2.5  | LOS A                  |
|                       |            | <b>Total</b> | <b>0.062</b>         | <b>5.7</b>              | <b>1.8</b>                                 | <b>LOS A</b>           |

Overall, the intersection of Elizabeth Street and Cooper Street performs satisfactorily at LOS A. The 95<sup>th</sup> percentile queue lengths are accommodated within the approach distances for all approaches.

**5.7.4 CEN04 – New Pedestrian Mid-block Crossing at Randle Lane**

The signalised pedestrian mid-block crossing at Randle Lane is located directly south of Central Station. During Block 1, the mid-block crossing was under construction and non-operational. As such, it was not assessed as part of the Block 1 study.

**5.7.5 CEN05 – Elizabeth Street / Randle Street**

The signalised intersection, composed of Elizabeth Street and Randle Street, is located south of Central Station. It connects the local road of Randle Street with the regional road of Elizabeth Street, linking the Sydney CBD to Waterloo.

Figure 5-56 illustrates both the general intersection layout as modelled in SIDRA Intersection and the layout as per aerial imagery.



Source: Nearmap, accessed on 24 March 2023

Figure 5-56 Block 1 - SIDRA Intersection layout (left) and Nearmap aerial imagery (right) of CEN05

Table 5-63 presents a performance summary of this intersection.



Table 5-63 Block 1 - Intersection performance summary of CEN05

| Intersection                                 | Peak       | Approach     | Degree of saturation | Average delay (seconds) | 95 <sup>th</sup> percentile queue (metres) | Level of service (LOS) |
|--|------------|--------------|----------------------|-------------------------|--|------------------------|
| Elizabeth Street / Randle Street<br>(Signal) | Weekday AM | North        | 0.247                | 2.6                     | 33.7                                       | LOS A                  |
|  |            | South-west   | 0.705                | 29.1                    | 169.0                                      | LOS C                  |
|  |            | <b>Total</b> | <b>0.705</b>         | <b>19.0</b>             | <b>169.0</b>                               | <b>LOS B</b>           |
|  | Weekday PM | North        | 0.329                | 2.9                     | 49.2                                       | LOS A                  |
|  |            | South-west   | 0.502                | 23.3                    | 106.6                                      | LOS B                  |
|  |            | <b>Total</b> | <b>0.502</b>         | <b>12.4</b>             | <b>106.6</b>                               | <b>LOS A</b>           |
|  | Weekend    | North        | 0.306                | 2.8                     | 44.6                                       | LOS A                  |
|  |            | South-west   | 0.604                | 25.5                    | 135.1                                      | LOS B                  |
|  |            | <b>Total</b> | <b>0.604</b>         | <b>14.8</b>             | <b>135.1</b>                               | <b>LOS B</b>           |

Overall, the intersection of Elizabeth Street and Randle Street performs satisfactorily at LOS B or better. The 95<sup>th</sup> percentile queues on Randle Street (south-west approach) extends back to Devonshire Street during the weekday AM peak and weekend peak hours.

## 5.8 Waterloo Station

Waterloo Station is a new underground station and the eighth stop on the City & Southwest Line (towards Sydenham). It is located in the north-western quadrant of Waterloo, bounded by Botany Road, Cope Street, Raglan Street and Wellington Street.

Waterloo Station was still under construction during Block 1. Construction access and egress to the station was facilitated via Cope Street, which was closed off to general traffic between Raglan Street and Wellington Street.

Bus services are available within approximately 150 metres of Waterloo Station, located along Botany Road. The existing bus stops will be retained for northbound routes, and the existing bus stops for southbound routes will be relocated to the mid-block on Botany Road, between Raglan Street and Wellington Street. A new on-road marked cycle link will be provided along Wellington Street.

The Waterloo Station study area consists of six intersections. During Block 1, WLO06 is a new unsignalised pedestrian mid-block crossing which had not yet been constructed. **Table 5-64** presents the peak hours utilised for modelling the intersections. **Table 5-65** provides a summary of the intersection level of service while

Figure 5-57 visualises a geospatial summary of the intersection level of service within the Waterloo Station study area.

**Table 5-64 Block 1 - Waterloo Station peak hours modelled**

| Network ID | Intersection ID | Weekday AM peak hour |            | Weekday PM peak hour |            | Weekend peak hour |            |
|------------|-----------------|----------------------|------------|----------------------|------------|-------------------|------------|
|            |                 | Day                  | Start time | Day                  | Start time | Day               | Start time |
| WLO-N1     | WLO01           | Wednesday            | 8.15am     | Wednesday            | 5.00pm     | Saturday          | 12.15pm    |
|            | WLO02           |                      |            |                      |            |                   |            |
|            | WLO03           |                      |            |                      |            |                   |            |
|            | WLO04           |                      |            |                      |            |                   |            |
|            | WLO05           |                      |            |                      |            |                   |            |
| -          | WLO06           | Under construction.  |            |                      |            |                   |            |

**Table 5-65 Block 1 - Waterloo Station intersection performance summary**

| Intersection ID | Intersection   | Level of service (LOS) |                 |              |
|-----------------|--|------------------------|-----------------|--------------|
|                 |  | Weekday AM Peak        | Weekday PM Peak | Weekend Peak |
| WLO01           | Botany Road / Raglan Street / Henderson Road (Signal)      | LOS C                  | LOS C           | LOS C        |
| WLO02           | Raglan Street / Cope Street (Roundabout)                   | LOS A                  | LOS A           | LOS A        |
| WLO03           | Botany Road / Wellington Street / Buckland Street (Signal) | LOS A                  | LOS A           | LOS A        |
| WLO04           | Cope Street / Wellington Street (Roundabout)               | LOS A                  | LOS A           | LOS A        |
| WLO05           | Wyndham Street / Henderson Road (Signal)                   | LOS C                  | LOS C           | LOS C        |

| Intersection ID | Intersection   | Level of service (LOS) |                 |              |
|-----------------|--|------------------------|-----------------|--------------|
|                 |  | Weekday AM Peak        | Weekday PM Peak | Weekend Peak |
| WLO06           | New Pedestrian Mid-block Crossing at Cope Street<br>(Pedestrian only – Signal) | Under construction.    |                 |              |

Overall, in the Waterloo Station study area, the intersection performance during the peak periods is satisfactory, operating at LOS C or better.



Figure 5-57 Block 1 – Waterloo Station geospatial intersection performance summary



**5.8.1 WLO01 – Botany Road / Raglan Street / Henderson Road**

The signalised intersection, composed of Botany Road, Raglan Street and Henderson Road, is located directly north-west of Waterloo Station. It connects the local road of Raglan Street in Waterloo with the state roads of Botany Road, linking Waterloo and Matraville, and Henderson Road, linking Waterloo and Eveleigh.

**Figure 5-58** illustrates both the general intersection layout as modelled in SIDRA Intersection and the layout as per aerial imagery.

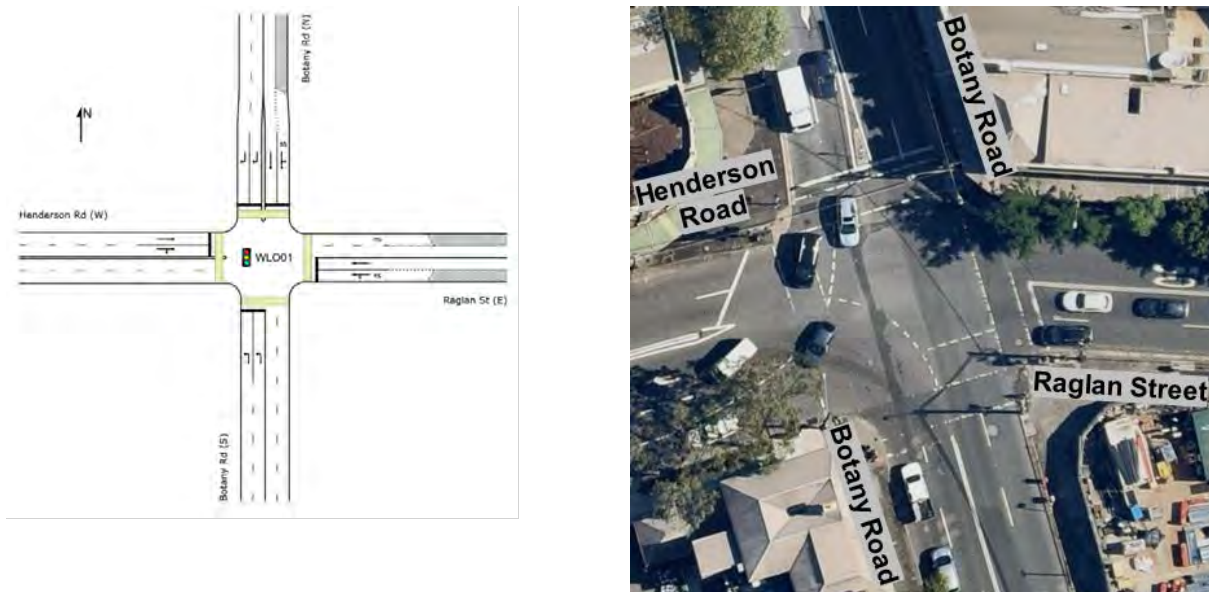

Source: Nearmap, accessed on 24 March 2023

**Figure 5-58 Block 1 - SIDRA Intersection layout (left) and Nearmap aerial imagery (right) of WLO01**

**Table 5-66** presents a performance summary of this intersection.

**Table 5-66 Block 1 - Intersection performance summary of WLO01**

| Intersection  | Peak       | Approach     | Degree of saturation | Average delay (seconds) | 95 <sup>th</sup> percentile queue (metres) | Level of service (LOS) |
|---|------------|--------------|----------------------|-------------------------|--|------------------------|
| Botany Road / Raglan Street / Henderson Road (Signal) | Weekday AM | South        | 0.775                | 33.0                    | 145.7                                      | LOS C                  |
|   |            | East         | 0.776                | 83.8                    | 60.1                                       | LOS F                  |
|   |            | North        | 0.789                | 25.0                    | 134.1                                      | LOS B                  |
|   |            | West         | 0.702                | 24.5                    | 41.7                                       | LOS B                  |
|   |            | <b>Total</b> | <b>0.789</b>         | <b>32.5</b>             | <b>145.7</b>                               | <b>LOS C</b>           |
|   | Weekday PM | South        | 0.702                | 49.7                    | 132.2                                      | LOS D                  |
|   |            | East         | 0.785                | 85.0                    | 57.8                                       | LOS F                  |
|   |            | North        | 0.747                | 22.9                    | 142.2                                      | LOS B                  |
|   |            | West         | 0.742                | 25.3                    | 43.5                                       | LOS B                  |
|   |            | <b>Total</b> | <b>0.785</b>         | <b>34.4</b>             | <b>142.2</b>                               | <b>LOS C</b>           |
|   | Weekend    | South        | 0.761                | 60.4                    | 109.5                                      | LOS E                  |
|   |            | East         | 0.733                | 78.1                    | 58.9                                       | LOS F                  |
| North   |            | 0.822        | 29.5                 | 155.8                   | LOS C                                      |                        |

| Intersection | Peak | Approach     | Degree of saturation | Average delay (seconds) | 95 <sup>th</sup> percentile queue (metres) | Level of service (LOS) |
|--------------|------|--------------|----------------------|-------------------------|--|------------------------|
|              |      | West         | 0.619                | 17.2                    | 27.7                                       | LOS B                  |
|              |      | <b>Total</b> | <b>0.822</b>         | <b>39.2</b>             | <b>155.8</b>                               | <b>LOS C</b>           |

Overall, the intersection of Botany Road, Raglan Street and Henderson Road performs satisfactorily at LOS C. The 95<sup>th</sup> percentile queue lengths on Raglan Street (east approach) extend back to Cope Street during all peak hours.

**5.8.2 WLO02 – Raglan Street / Cope Street**

The roundabout, composed of Raglan Street and Cope Street, is located directly north-east of Waterloo Station. It connects the local roads of Raglan Street and Cope Street in Waterloo. During Block 1, Cope Street (south approach) was closed off due to Sydney Metro construction works.

**Figure 5-59** illustrates both the general intersection layout as modelled in SIDRA Intersection and the layout as per aerial imagery.

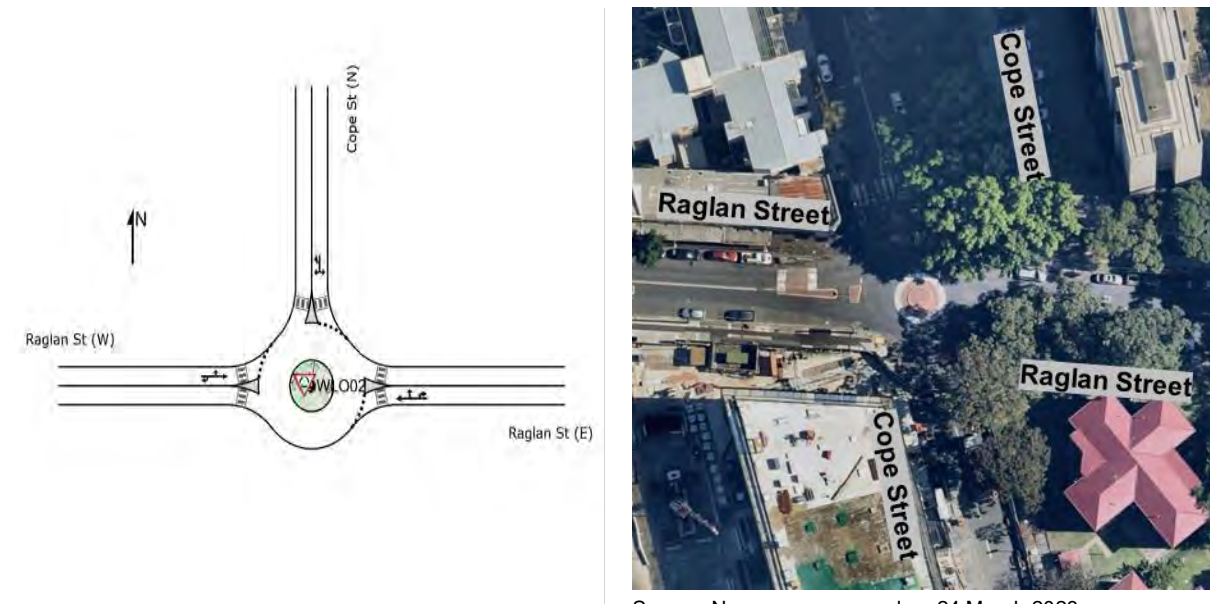

Source: Nearmap, accessed on 24 March 2023

**Figure 5-59** Block 1 - SIDRA Intersection layout (left) and Nearmap aerial imagery (right) of WLO02

**Table 5-67** presents a performance summary of this intersection.

**Table 5-67** Block 1 - Intersection performance summary of WLO02

| Intersection                                | Peak       | Approach     | Degree of saturation | Average delay (seconds) | 95 <sup>th</sup> percentile queue (metres) | Level of service (LOS) |
|---|------------|--------------|----------------------|-------------------------|--|------------------------|
| Raglan Street / Cope Street<br>(Roundabout) | Weekday AM | East         | 0.198                | 8.7                     | 9.7  | LOS A                  |
|   |            | North        | 0.082                | 9.6                     | 3.6  | LOS A                  |
|   |            | West         | 0.219                | 8.4                     | 9.1  | LOS A                  |
|   |            | <b>Total</b> | <b>0.082</b>         | <b>9.6</b>              | <b>3.6</b>                                 | <b>LOS A</b>           |
|   |            | East         | 0.186                | 8.8                     | 8.8  | LOS A                  |

| Intersection | Peak       | Approach     | Degree of saturation | Average delay (seconds) | 95 <sup>th</sup> percentile queue (metres) | Level of service (LOS) |
|--------------|------------|--------------|----------------------|-------------------------|--|------------------------|
|              | Weekday PM | North        | 0.099                | 9.7                     | 4.2  | LOS A                  |
|              |            | West         | 0.202                | 8.4                     | 8.4  | LOS A                  |
|              |            | <b>Total</b> | <b>0.099</b>         | <b>9.7</b>              | <b>4.2</b>                                 | <b>LOS A</b>           |
|              | Weekend    | East         | 0.171                | 8.8                     | 8.1  | LOS A                  |
|              |            | North        | 0.097                | 10.1                    | 4.1  | LOS A                  |
|              |            | West         | 0.231                | 8.4                     | 10.2                                       | LOS A                  |
|              |            | <b>Total</b> | <b>0.097</b>         | <b>10.1</b>             | <b>4.1</b>                                 | <b>LOS A</b>           |

Overall, the intersection of Raglan Street and Cope Street performs satisfactorily at LOS A. The 95<sup>th</sup> percentile queue lengths are accommodated within the approach distances for all approaches.

**5.8.3 WLO03 – Botany Road / Wellington Street / Buckland Street**

The signalised intersection, composed of Botany Road, Wellington Street and Buckland Street, is located directly south-west of Waterloo Station. It connects the local roads of Wellington Street in Waterloo and Buckland Street, linking Waterloo and Alexandria, with the state road of Botany Road, linking Waterloo and Matraville.

Figure 5-60 illustrates both the general intersection layout as modelled in SIDRA Intersection and the layout as per aerial imagery.



Source: Nearmap, accessed on 24 March 2023

Figure 5-60 Block 1 - SIDRA Intersection layout (left) and Nearmap aerial imagery (right) of WLO03

Table 5-68 presents a performance summary of this intersection.

Table 5-68 Block 1 - Intersection performance summary of WLO03

| Intersection  | Peak       | Approach     | Degree of saturation | Average delay (seconds) | 95 <sup>th</sup> percentile queue (metres) | Level of service (LOS) |
|---|------------|--------------|----------------------|-------------------------|--|------------------------|
| Botany Road / Wellington Street / Buckland Street<br>(Signal) | Weekday AM | South        | 0.484                | 10.5                    | 119.6                                      | LOS A                  |
|   |            | East         | 0.168                | 51.6                    | 18.1                                       | LOS D                  |
|   |            | North        | 0.390                | 6.8                     | 78.6                                       | LOS A                  |
|   |            | West         | 0.332                | 46.3                    | 45.3                                       | LOS D                  |
|   |            | <b>Total</b> | <b>0.484</b>         | <b>12.5</b>             | <b>119.6</b>                               | <b>LOS A</b>           |
|   | Weekday PM | South        | 0.332                | 6.1                     | 64.1                                       | LOS A                  |
|   |            | East         | 0.317                | 57.7                    | 26.4                                       | LOS E                  |
|   |            | North        | 0.399                | 2.5                     | 44.8                                       | LOS A                  |
|   |            | West         | 0.246                | 50.9                    | 25.9                                       | LOS D                  |
|   |            | <b>Total</b> | <b>0.399</b>         | <b>8.8</b>              | <b>64.1</b>                                | <b>LOS A</b>           |
|   | Weekend    | South        | 0.402                | 7.6                     | 64.5                                       | LOS A                  |
|   |            | East         | 0.276                | 58.0                    | 25.8                                       | LOS E                  |
|   |            | North        | 0.563                | 6.7                     | 63.7                                       | LOS A                  |
|   |            | West         | 0.313                | 51.7                    | 33.2                                       | LOS D                  |
|   |            | <b>Total</b> | <b>0.563</b>         | <b>13.9</b>             | <b>64.5</b>                                | <b>LOS A</b>           |

Overall, the intersection of Botany Road, Wellington Street and Buckland Street performs satisfactorily at LOS A. The 95<sup>th</sup> percentile queue lengths are accommodated within the approach distances for all approaches.

#### 5.8.4 WLO04 – Cope Street / Wellington Street

The roundabout, composed of Cope Street and Wellington Street, is located directly south-east of Waterloo Station. It connects the local roads of Cope Street, linking Waterloo and Redfern, and Wellington Street in Waterloo. During Block 1, the Cope Street northern approach was closed off due to Sydney Metro construction works.

**Figure 5-61** illustrates both the general intersection layout as modelled in SIDRA Intersection and the layout as per aerial imagery.



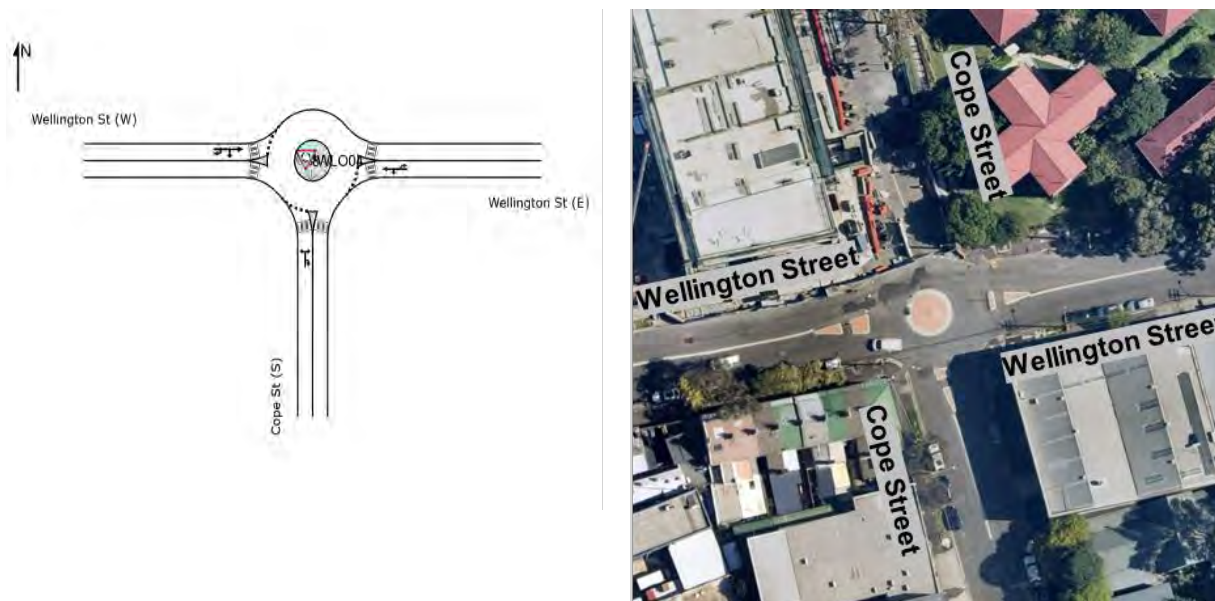

Source: Nearmap, accessed on 24 March 2023

Figure 5-61 Block 1 - SIDRA Intersection layout (left) and Nearmap aerial imagery (right) of WLO04

Table 5-69 presents a performance summary of this intersection.

Table 5-69 Block 1 - Intersection performance summary of WLO04

| Intersection                                    | Peak       | Approach     | Degree of saturation | Average delay (seconds) | 95 <sup>th</sup> percentile queue (metres) | Level of service (LOS) |
|---|------------|--------------|----------------------|-------------------------|--|------------------------|
| Cope Street / Wellington Street<br>(Roundabout) | Weekday AM | South        | 0.026                | 8.4                     | 1.0  | LOS A                  |
|   |            | East         | 0.053                | 8.2                     | 2.4  | LOS A                  |
|   |            | West         | 0.166                | 7.9                     | 6.5  | LOS A                  |
|   |            | <b>Total</b> | <b>0.026</b>         | <b>8.4</b>              | <b>1.0</b>                                 | <b>LOS A</b>           |
|   | Weekday PM | South        | 0.036                | 9.2                     | 1.4  | LOS A                  |
|   |            | East         | 0.076                | 9.4                     | 3.3  | LOS A                  |
|   |            | West         | 0.111                | 7.9                     | 4.1  | LOS A                  |
|   |            | <b>Total</b> | <b>0.076</b>         | <b>9.4</b>              | <b>3.3</b>                                 | <b>LOS A</b>           |
|   | Weekend    | South        | 0.026                | 8.6                     | 1.0  | LOS A                  |
|   |            | East         | 0.069                | 8.1                     | 2.9  | LOS A                  |
|   |            | West         | 0.113                | 7.8                     | 4.0  | LOS A                  |
|   |            | <b>Total</b> | <b>0.026</b>         | <b>8.6</b>              | <b>1.0</b>                                 | <b>LOS A</b>           |

Overall, the intersection of Cope Street and Wellington Street performs satisfactorily at LOS A. The 95<sup>th</sup> percentile queue lengths are accommodated within the approach distances for all approaches.

**5.8.5 WLO05 – Wyndham Street / Henderson Road**

The signalised intersection, composed of Wyndham Street and Henderson Road, is located west of Waterloo Station. It connects Henderson Road, linking Waterloo and Eveleigh, and Wyndham Street in Alexandria.

Figure 5-62 illustrates both the general intersection layout as modelled in SIDRA Intersection and the layout as per aerial imagery.

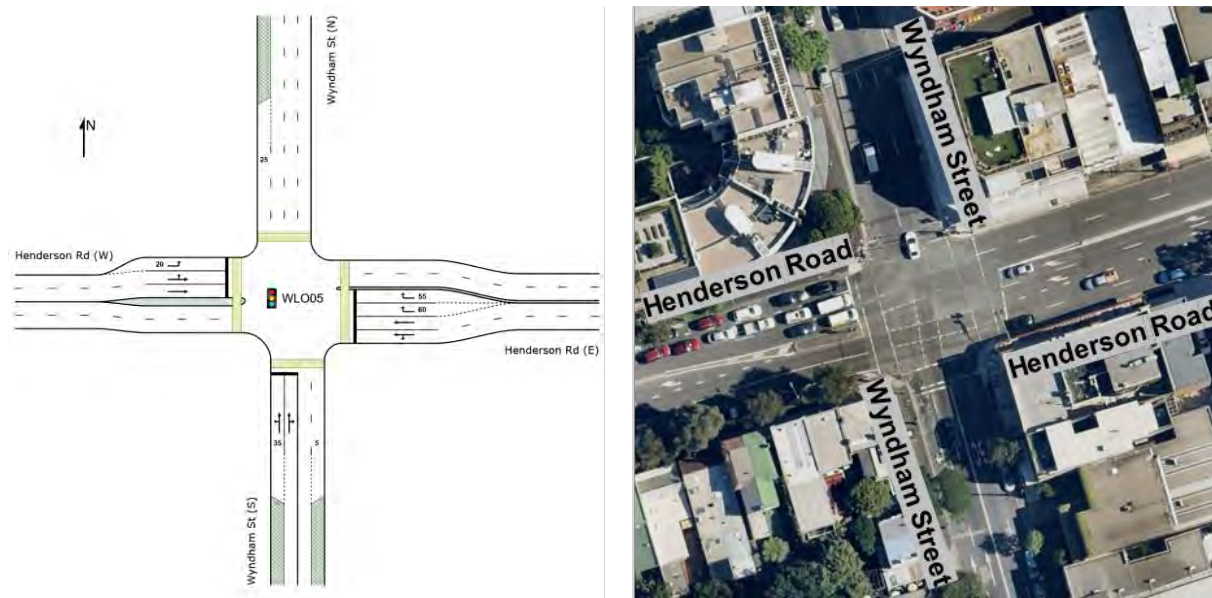

Source: Nearmap, accessed on 24 March 2023

Figure 5-62 Block 1 - SIDRA Intersection layout (left) and Nearmap aerial imagery (right) of WLO05

Table 5-70 presents a performance summary of this intersection.

Table 5-70 Block 1 - Intersection performance summary of WLO05

| Intersection                             | Peak       | Approach     | Degree of saturation | Average delay (seconds) | 95 <sup>th</sup> percentile queue (metres) | Level of service (LOS) |
|--|------------|--------------|----------------------|-------------------------|--|------------------------|
| Wyndham Street / Henderson Road (Signal) | Weekday AM | South        | 0.793                | 68.2                    | 103.0                                      | LOS E                  |
|  |            | East         | 0.675                | 9.8                     | 67.7                                       | LOS A                  |
|  |            | West         | 0.851                | 68.5                    | 126.3                                      | LOS E                  |
|  |            | <b>Total</b> | <b>0.851</b>         | <b>33.2</b>             | <b>126.3</b>                               | <b>LOS C</b>           |
|  | Weekday PM | South        | 0.848                | 73.8                    | 123.3                                      | LOS F                  |
|  |            | East         | 0.568                | 9.6                     | 49.2                                       | LOS A                  |
|  |            | West         | 0.776                | 65.4                    | 98.1                                       | LOS E                  |
|  |            | <b>Total</b> | <b>0.848</b>         | <b>34.2</b>             | <b>123.3</b>                               | <b>LOS C</b>           |
|  | Weekend    | South        | 0.726                | 61.6                    | 92.2                                       | LOS E                  |
|  |            | East         | 0.412                | 12.5                    | 71.7                                       | LOS A                  |
|  |            | West         | 0.885                | 71.7                    | 147.0                                      | LOS F                  |
|  |            | <b>Total</b> | <b>0.885</b>         | <b>37.1</b>             | <b>147.0</b>                               | <b>LOS C</b>           |

Overall, the intersection of Wyndham Street and Henderson Road performs satisfactorily at LOS C. The 95<sup>th</sup> percentile queues on Henderson Street (east approach) extend back to Botany Road during the weekday AM peak and weekend peak hours. Similarly, the 95<sup>th</sup> percentile queues on Henderson Street (west approach) extend back to Garden Street during all peak hours.

#### **5.8.6 WLO06 – New Pedestrian Mid-block Crossing at Cope Street**

The new unsignalised pedestrian mid-block crossing at Cope Street is located directly east of Waterloo Station. During Block 1, the mid-block crossing was under construction and non-operational. As such, it was not assessed as part of the Block 1 study.

## 5.9 Sydenham Station

Sydenham Station is an existing station and the ninth stop on the City & Southwest Line (towards Sydenham). It is located in the north-western area of Sydenham, bounded by Railway Parade, Gleeson Avenue, and Burrows Avenue in Sydenham.

Platforms 1 and 2 of the existing Sydenham Station are currently being upgraded and extended to facilitate metro functionality. In addition to the existing entrance at Gleeson Avenue, two new entrances will be constructed – one in the north and the other in the south. The northern entry will open onto a plaza near the corner of Railway Parade and the southern entry, which was operable during Block 1, provides access onto a plaza on Burrows Avenue near Hogan Avenue.

Bus services are provided within approximately 100 metres of Sydenham Station, locating along Burrows Avenue and Railway Parade.

The Sydenham Station study area consists of six intersections. **Table 5-71** presents the peak hours utilised for modelling the intersections. **Table 5-72** provides a summary of the intersection level of service while

Figure 5-63 visualises a geospatial summary of the intersection level of service within the Sydenham Station study area.

**Table 5-71 Block 1 - Sydenham Station peak hours modelled**

| Network ID | Intersection ID | Weekday AM peak hour |            | Weekday PM peak hour |            | Weekend peak hour |            |
|------------|-----------------|----------------------|------------|----------------------|------------|-------------------|------------|
|            |                 | Day                  | Start time | Day                  | Start time | Day               | Start time |
| SYD-N1     | SYD01           | Wednesday            | 7.45am     | Wednesday            | 3.30pm     | Saturday          | 1.00pm     |
|            | SYD02           |                      |            |                      |            |                   |            |
| -          | SYD03           | Tuesday              | 7.30am     | Tuesday              | 3.45pm     | Saturday          | 1.00pm     |
| -          | SYD04           | Tuesday              | 8.15am     | Tuesday              | 4.15pm     | Saturday          | 1.45pm     |
| -          | SYD05           | Tuesday              | 8.15am     | Tuesday              | 4.45pm     | Saturday          | 1.45pm     |
| -          | SYD06           | Tuesday              | 8.15am     | Friday               | 3.15pm     | Saturday          | 10.30am    |

**Table 5-72 Block 1 - Sydenham Station intersection performance summary**

| Intersection ID | Intersection  | Level of service (LOS) |                 |              |
|-----------------|---|------------------------|-----------------|--------------|
|                 |   | Weekday AM Peak        | Weekday PM Peak | Weekend Peak |
| SYD01           | Railway Parade / Gleeson Avenue (Signal)                                  | LOS A                  | LOS A           | LOS A        |
| SYD02           | Burrows Avenue / Gleeson Avenue (Signal)                                  | LOS B                  | LOS B           | LOS B        |
| SYD03           | Burrows Avenue / George Street (Priority – Give Way)                      | LOS A                  | LOS A           | LOS A        |
| SYD04           | Pedestrian Mid-block Crossing at Sydenham Road (Pedestrian only - Signal) | LOS A                  | LOS A           | LOS A        |
| SYD05           | Marrickville Road / Buckley Street (Priority – Give Way)                  | LOS A                  | LOS A           | LOS A        |
| SYD06           | Sydenham Road / Buckley Street (Priority – Give Way)                      | LOS A                  | LOS A           | LOS A        |

Overall, in the Sydenham Station study area, the intersection performance during the peak periods is satisfactory, operating at LOS B or better.



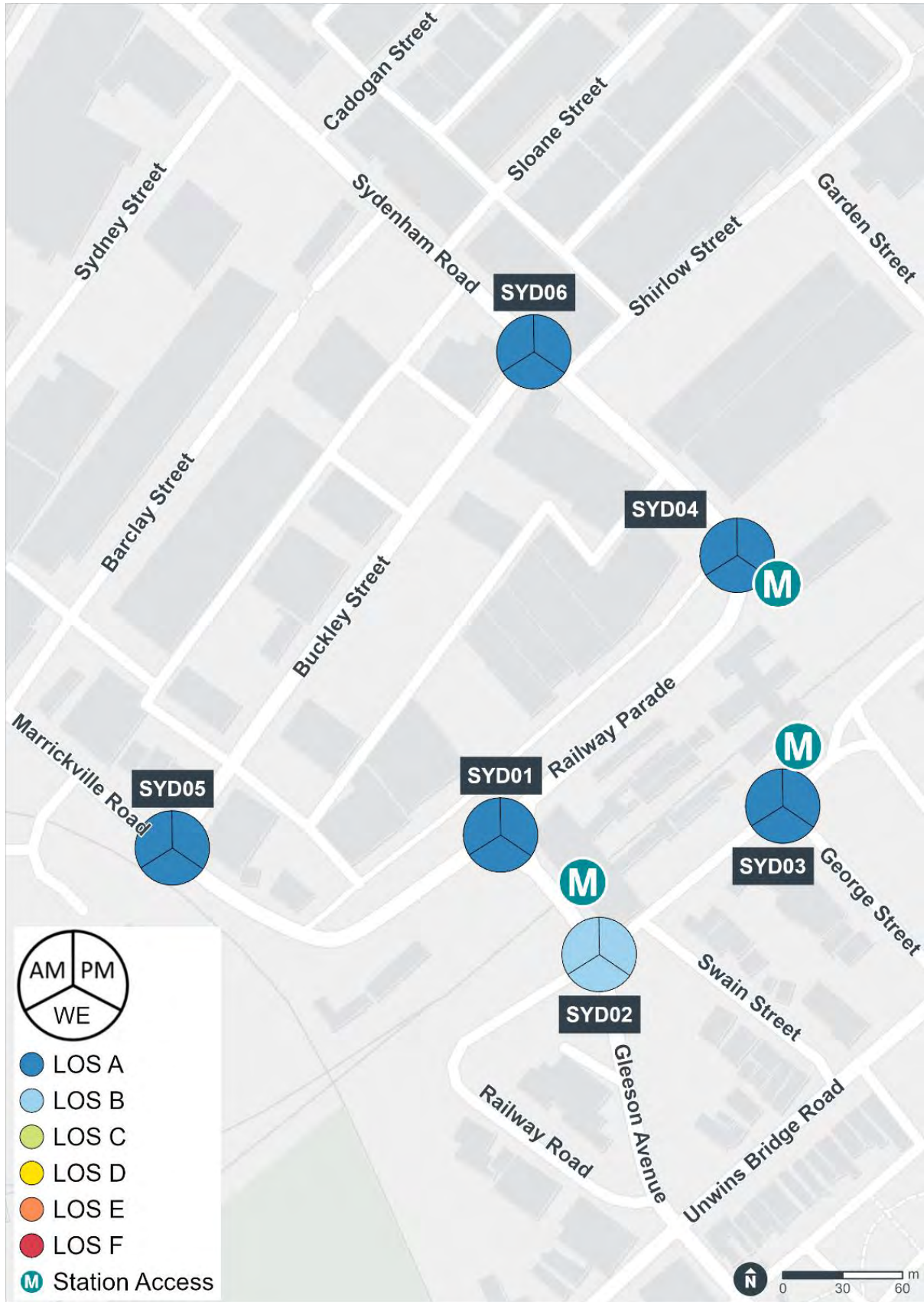
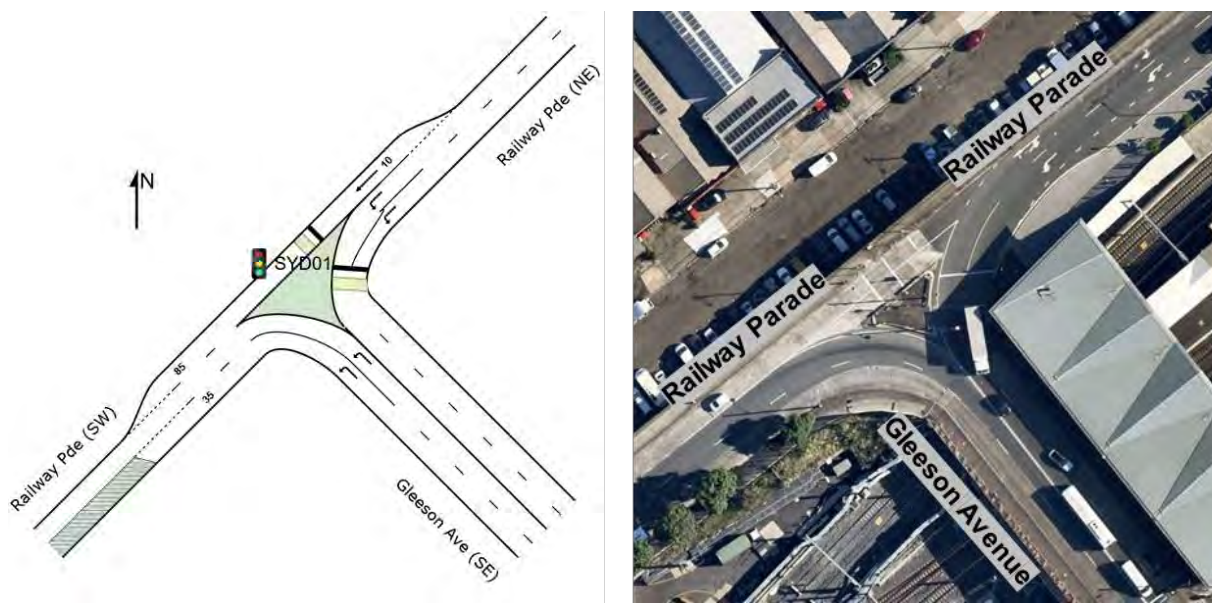

Figure 5-63 Block 1 – Sydenham Station geospatial intersection performance summary

### 5.9.1 SYD01 – Railway Parade / Gleeson Avenue

The signalised intersection, composed of Railway Parade and Gleeson Avenue, is located directly west of Sydenham Station. It connects the state roads of Railway Parade and Gleeson Avenue in Sydenham.

Figure 5-64 illustrates both the general intersection layout as modelled in SIDRA Intersection and the layout as per aerial imagery.



Source: Nearmap, accessed on 24 March 2023

Figure 5-64 Block 1 - SIDRA Intersection layout (left) and Nearmap aerial imagery (right) of SYD01

Table 5-73 presents a performance summary of this intersection.

Table 5-73 Block 1 - Intersection performance summary of SYD01

| Intersection                             | Peak       | Approach     | Degree of saturation | Average delay (seconds) | 95 <sup>th</sup> percentile queue (metres) | Level of service (LOS) |
|--|------------|--------------|----------------------|-------------------------|--|------------------------|
| Railway Parade / Gleeson Avenue (Signal) | Weekday AM | South-east   | 0.381                | 4.8                     | 0.0  | LOS A                  |
|  |            | North-east   | 0.529                | 11.7                    | 78.2                                       | LOS A                  |
|  |            | <b>Total</b> | <b>0.529</b>         | <b>8.8</b>              | <b>78.2</b>                                | <b>LOS A</b>           |
|  | Weekday PM | South-east   | 0.418                | 4.9                     | 0.0  | LOS A                  |
|  |            | North-east   | 0.355                | 9.2                     | 45.7                                       | LOS A                  |
|  |            | <b>Total</b> | <b>0.418</b>         | <b>7.1</b>              | <b>45.7</b>                                | <b>LOS A</b>           |
|  | Weekend    | South-east   | 0.375                | 4.8                     | 0.0  | LOS A                  |
|  |            | North-east   | 0.331                | 7.1                     | 35.0                                       | LOS A                  |
|  |            | <b>Total</b> | <b>0.375</b>         | <b>6.0</b>              | <b>35.0</b>                                | <b>LOS A</b>           |

Overall, the intersection of Railway Parade and Gleeson Avenue performs satisfactorily at LOS A. The 95<sup>th</sup> percentile queue lengths are accommodated within the approach distances for all approaches.

### 5.9.2 SYD02 – Burrows Avenue / Gleeson Avenue

The signalised intersection, composed of Burrows Avenue and Gleeson Avenue, is located directly south of Sydenham Station. It connects the local road of Burrows Avenue with the state road of Gleeson Avenue in Sydenham.

Figure 5-65 illustrates both the general intersection layout as modelled in SIDRA Intersection and the layout as per aerial imagery.

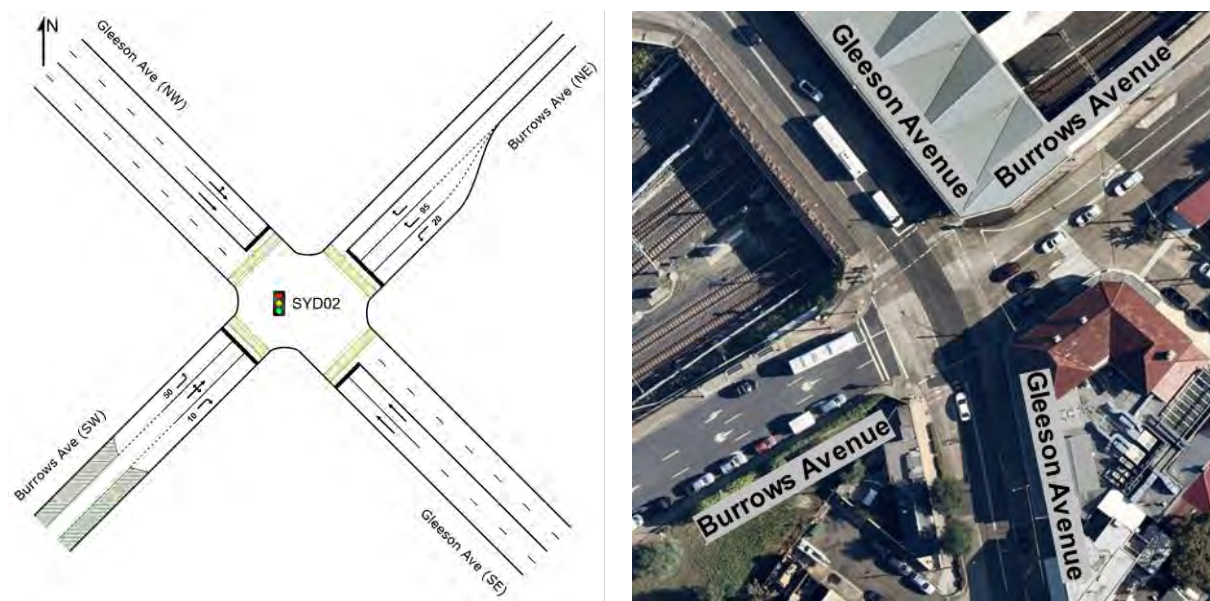

Source: Nearmap, accessed on 24 March 2023

Figure 5-65 Block 1 - SIDRA Intersection layout (left) and Nearmap aerial imagery (right) of SYD02

Table 5-74 presents a performance summary of this intersection.

Table 5-74 Block 1 - Intersection performance summary of SYD02

| Intersection                             | Peak       | Approach     | Degree of saturation | Average delay (seconds) | 95 <sup>th</sup> percentile queue (metres) | Level of service (LOS) |
|--|------------|--------------|----------------------|-------------------------|--|------------------------|
| Burrows Avenue / Gleeson Avenue (Signal) | Weekday AM | South-east   | 0.311                | 14.0                    | 66.4                                       | LOS A                  |
|  |            | North-east   | 0.514                | 57.5                    | 44.0                                       | LOS E                  |
|  |            | North-west   | 0.564                | 5.8                     | 65.9                                       | LOS A                  |
|  |            | South-west   | 0.091                | 54.4                    | 5.0  | LOS D                  |
|  |            | <b>Total</b> | <b>0.564</b>         | <b>15.8</b>             | <b>66.4</b>                                | <b>LOS B</b>           |
|  | Weekday PM | South-east   | 0.336                | 13.8                    | 66.8                                       | LOS A                  |
|  |            | North-east   | 0.554                | 53.3                    | 47.5                                       | LOS D                  |
|  |            | North-west   | 0.494                | 5.1                     | 46.0                                       | LOS A                  |
|  |            | South-west   | 0.131                | 49.5                    | 7.1  | LOS D                  |
|  |            | <b>Total</b> | <b>0.554</b>         | <b>16.5</b>             | <b>66.8</b>                                | <b>LOS B</b>           |
|  | Weekend    | South-east   | 0.289                | 12.2                    | 60.8                                       | LOS A                  |
|  |            | North-east   | 0.481                | 51.0                    | 48.6                                       | LOS D                  |
| North-west                               |            | 0.509        | 5.7                  | 57.2                    | LOS A                                      |                        |



| Intersection | Peak | Approach     | Degree of saturation | Average delay (seconds) | 95 <sup>th</sup> percentile queue (metres) | Level of service (LOS) |
|--------------|------|--------------|----------------------|-------------------------|--|------------------------|
|              |      | South-west   | 0.216                | 57.8                    | 9.2  | LOS E                  |
|              |      | <b>Total</b> | <b>0.509</b>         | <b>15.1</b>             | <b>60.8</b>                                | <b>LOS B</b>           |

Overall, the intersection of Burrows Avenue and Gleeson Avenue performs satisfactorily at LOS B. The 95<sup>th</sup> percentile queues on Gleeson Avenue (north-west approach) extend back to Railway Parade during the weekday AM peak and weekend peak hours.

**5.9.3 SYD03 – Burrows Avenue / George Street**

The priority intersection, composed of Burrows Avenue and George Street, is located directly east of Sydenham Station. It connects the local roads of Burrows Avenue and George Street in Sydenham.

Figure 5-66 illustrates both the general intersection layout as modelled in SIDRA Intersection and the layout as per aerial imagery.



Source: Nearmap, accessed on 24 March 2023

Figure 5-66 Block 1 - SIDRA Intersection layout (left) and Nearmap aerial imagery (right) of SYD03

Table 5-75 presents a performance summary of this intersection.

Table 5-75 Block 1 - Intersection performance summary of SYD03

| Intersection                   | Peak       | Approach     | Degree of saturation | Average delay (seconds) | 95 <sup>th</sup> percentile queue (metres) | Level of service (LOS) |
|--------------------------------|------------|--------------|----------------------|-------------------------|--|------------------------|
| Burrows Avenue / George Street | Weekday AM | South-east   | 0.022                | 9.8                     | 0.5  | LOS A                  |
|                                |            | North-east   | 0.206                | 4.2                     | 8.1  | LOS A                  |
|                                |            | South-west   | 0.225                | 6.4                     | 7.7  | LOS A                  |
|                                |            | <b>Total</b> | <b>0.022</b>         | <b>9.8</b>              | <b>0.5</b>                                 | <b>LOS A</b>           |
| (Priority – Give Way)          | Weekday PM | South-east   | 0.007                | 9.7                     | 0.1  | LOS A                  |
|                                |            | North-east   | 0.271                | 3.9                     | 11.1                                       | LOS A                  |



| Intersection | Peak    | Approach     | Degree of saturation | Average delay (seconds) | 95 <sup>th</sup> percentile queue (metres) | Level of service (LOS) |
|--------------|---------|--------------|----------------------|-------------------------|--|------------------------|
|              |         | South-west   | 0.169                | 7.1                     | 5.4  | LOS A                  |
|              |         | <b>Total</b> | <b>0.007</b>         | <b>9.7</b>              | <b>0.1</b>                                 | <b>LOS A</b>           |
|              | Weekend | South-east   | 0.020                | 9.1                     | 0.4  | LOS A                  |
|              |         | North-east   | 0.171                | 3.7                     | 6.4  | LOS A                  |
|              |         | South-west   | 0.204                | 5.3                     | 6.7  | LOS A                  |
|              |         | <b>Total</b> | <b>0.020</b>         | <b>9.1</b>              | <b>0.4</b>                                 | <b>LOS A</b>           |

Overall, the intersection of Burrows Avenue and George Street performs satisfactorily at LOS A. The 95<sup>th</sup> percentile queue lengths are accommodated within the approach distances for all approaches.

**5.9.4 SYD04 – Pedestrian Mid-block Crossing at Sydenham Road**

The signalised pedestrian mid-block crossing at Sydenham Road is located north of Sydenham Station. It offers a signalised pedestrian crossing over Sydenham Road, a state road linking Sydenham and Marrickville.

Figure 5-67 illustrates both the general intersection layout as modelled in SIDRA Intersection and the layout as per aerial imagery.

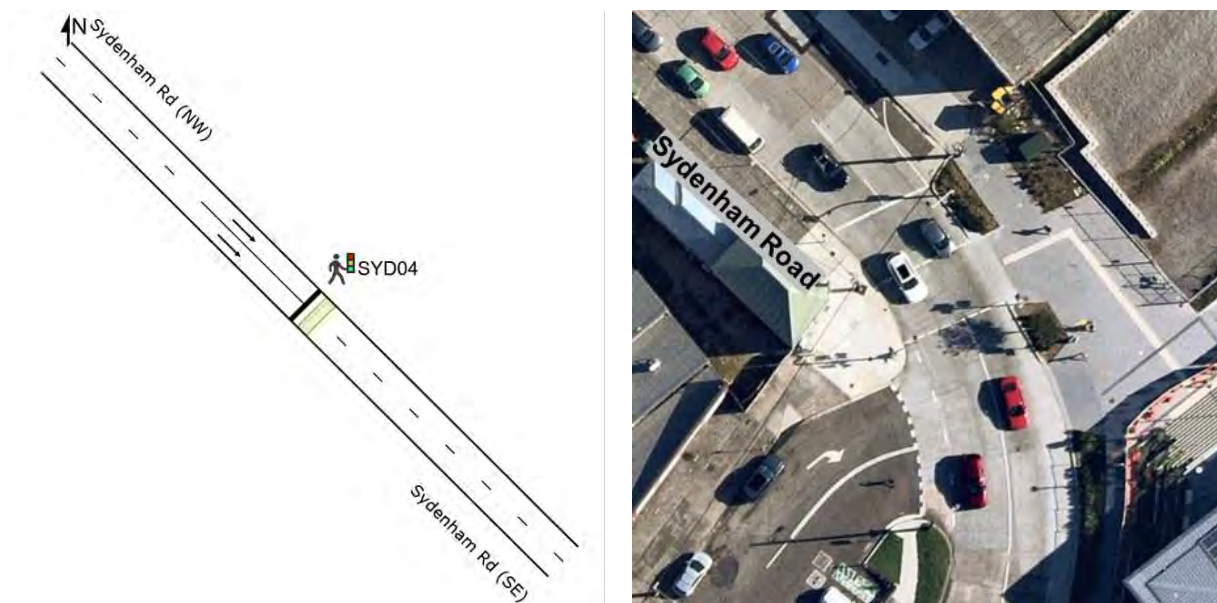

Source: Nearmap, accessed on 24 March 2023

Figure 5-67 Block 1 - SIDRA Intersection layout (left) and Nearmap aerial imagery (right) of SYD04

Table 5-76 presents a performance summary of this intersection.

Table 5-76 Block 1 - Intersection performance summary of SYD04

| Intersection         | Peak       | Approach     | Degree of saturation | Average delay (seconds) | 95 <sup>th</sup> percentile queue (metres) | Level of service (LOS) |
|----------------------|------------|--------------|----------------------|-------------------------|--|------------------------|
| Pedestrian Mid-block | Weekday AM | North-west   | 0.445                | 5.9                     | 60.7                                       | LOS A                  |
|                      |            | <b>Total</b> | <b>0.445</b>         | <b>5.9</b>              | <b>60.7</b>                                | <b>LOS A</b>           |

| Intersection               | Peak       | Approach     | Degree of saturation | Average delay (seconds) | 95 <sup>th</sup> percentile queue (metres) | Level of service (LOS) |
|----------------------------|------------|--------------|----------------------|-------------------------|--|------------------------|
| Crossing at Sydenham Road  | Weekday PM | North-west   | 0.393                | 5.3                     | 54.5                                       | LOS A                  |
|                            |            | <b>Total</b> | <b>0.393</b>         | <b>5.3</b>              | <b>54.5</b>                                | <b>LOS A</b>           |
| (Pedestrian only - Signal) | Weekend    | North-west   | 0.394                | 5.4                     | 54.5                                       | LOS A                  |
|                            |            | <b>Total</b> | <b>0.394</b>         | <b>5.4</b>              | <b>54.5</b>                                | <b>LOS A</b>           |

Overall, the pedestrian mid-block crossing at Sydenham Road performs satisfactorily at LOS A. The 95<sup>th</sup> percentile queue lengths are accommodated within the approach distances for all approaches.

**5.9.5 SYD05 – Marrickville Road / Buckley Street**

The priority intersection, composed of Marrickville Road and Buckley Street, is located west of Sydenham Station. It connects the state roads of Buckley Street in Sydenham and Marrickville Road, linking Sydenham and Dulwich Hill.

**Figure 5-68** illustrates both the general intersection layout as modelled in SIDRA Intersection and the layout as per aerial imagery.

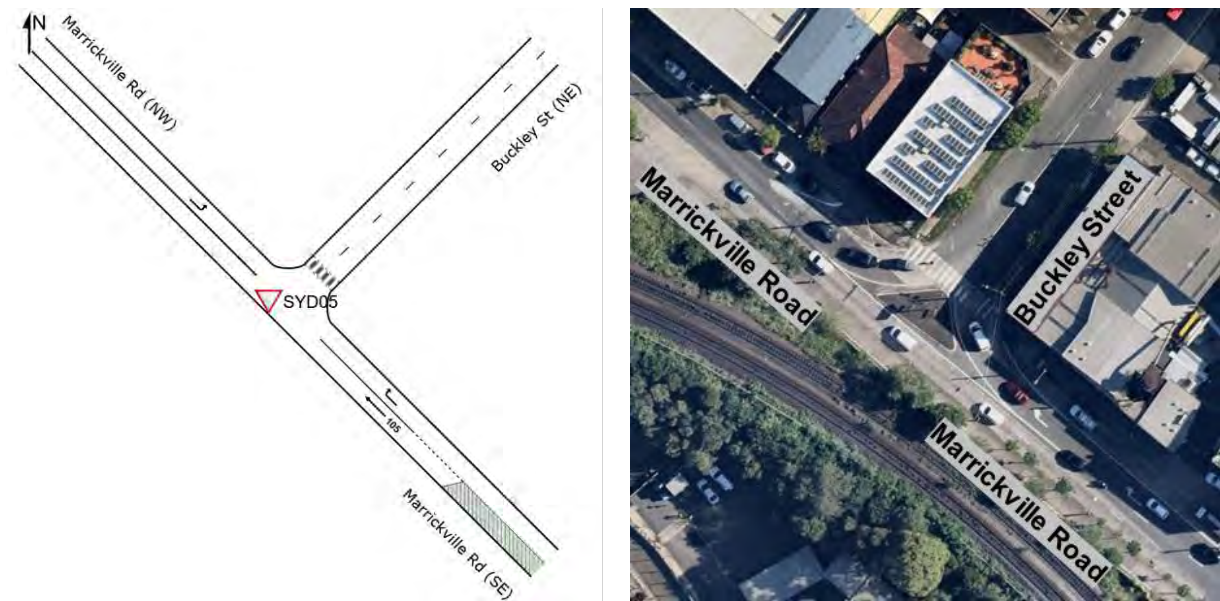

Source: Nearmap, accessed on 24 March 2023

**Figure 5-68** Block 1 - SIDRA Intersection layout (left) and Nearmap aerial imagery (right) of SYD05

**Table 5-77** presents a performance summary of this intersection.

**Table 5-77 Block 1 - Intersection performance summary of SYD05**

| Intersection  | Peak       | Approach     | Degree of saturation | Average delay (seconds) | 95 <sup>th</sup> percentile queue (metres) | Level of service (LOS) |
|---|------------|--------------|----------------------|-------------------------|--|------------------------|
| Marrickville Road / Buckley Street<br><br>(Priority – Give Way) | Weekday AM | South-east   | 0.747                | 8.1                     | 44.1                                       | LOS A                  |
|   |            | North-west   | 0.727                | 8.2                     | 36.0                                       | LOS A                  |
|   |            | <b>Total</b> | <b>0.727</b>         | <b>8.2</b>              | <b>36.0</b>                                | <b>LOS A</b>           |
|   | Weekday PM | South-east   | 0.607                | 6.4                     | 20.8                                       | LOS A                  |
|   |            | North-west   | 0.586                | 6.5                     | 15.2                                       | LOS A                  |
|   |            | <b>Total</b> | <b>0.586</b>         | <b>6.5</b>              | <b>15.2</b>                                | <b>LOS A</b>           |
|   | Weekend    | South-east   | 0.306                | 5.9                     | 11.4                                       | LOS A                  |
|   |            | North-west   | 0.301                | 5.8                     | 10.3                                       | LOS A                  |
|   |            | <b>Total</b> | <b>0.306</b>         | <b>5.9</b>              | <b>11.4</b>                                | <b>LOS A</b>           |

Overall, the intersection of Marrickville Road and Buckley Street performs satisfactorily at LOS A. The 95<sup>th</sup> percentile queue lengths are accommodated within the approach distances for all approaches.

**5.9.6 SYD06 – Sydenham Road / Buckley Street**

The priority intersection, composed of Sydenham Road and Buckley Street, is located north of Sydenham Station. It connects the state roads of Buckley Street in Sydenham and Sydenham Road, linking Sydenham and Marrickville.

**Figure 5-69** illustrates both the general intersection layout as modelled in SIDRA Intersection and the layout as per aerial imagery.

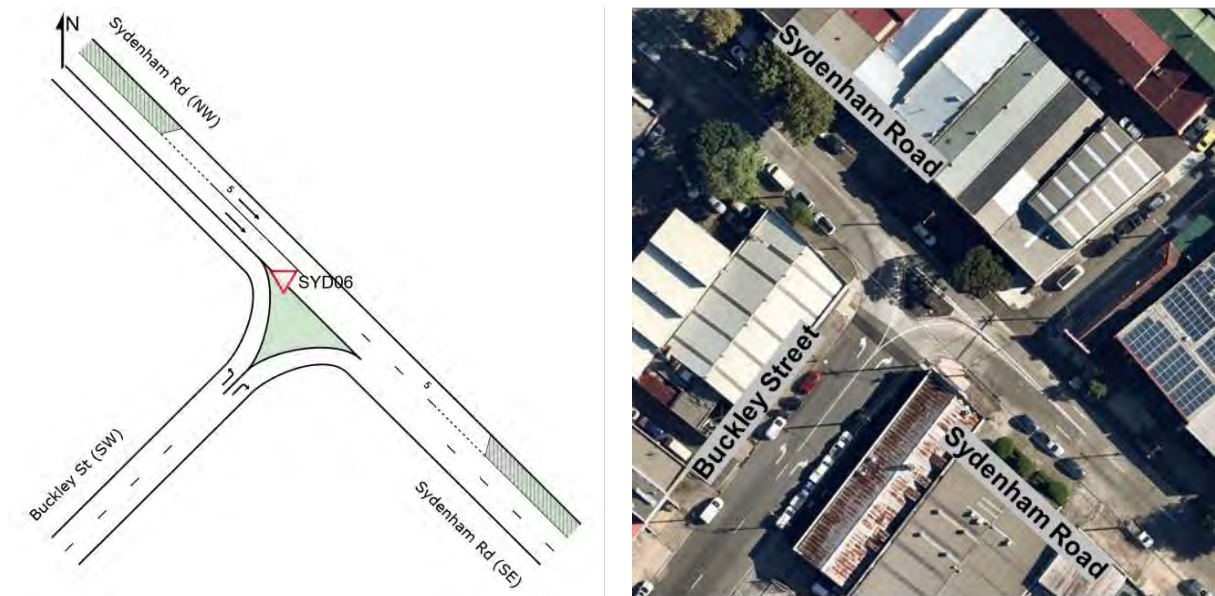

Source: Nearmap, accessed on 24 March 2023

**Figure 5-69 Block 1 - SIDRA Intersection layout (left) and Nearmap aerial imagery (right) of SYD06**

**Table 5-78** presents a performance summary of this intersection.

Table 5-78 Block 1 - Intersection performance summary of SYD06

| Intersection  | Peak       | Approach     | Degree of saturation | Average delay (seconds) | 95 <sup>th</sup> percentile queue (metres) | Level of service (LOS) |
|---|------------|--------------|----------------------|-------------------------|--|------------------------|
| Sydenham Road / Buckley Street<br>(Priority – Give Way) | Weekday AM | North-west   | 0.404                | 0.1                     | 0.0  | LOS A                  |
|   |            | South-west   | 0.234                | 5.9                     | 0.0  | LOS A                  |
|   |            | <b>Total</b> | <b>0.234</b>         | <b>5.9</b>              | <b>0.0</b>                                 | <b>LOS A</b>           |
|   | Weekday PM | North-west   | 0.412                | 0.1                     | 0.0  | LOS A                  |
|   |            | South-west   | 0.212                | 5.8                     | 0.0  | LOS A                  |
|   |            | <b>Total</b> | <b>0.212</b>         | <b>5.8</b>              | <b>0.0</b>                                 | <b>LOS A</b>           |
|   | Weekend    | North-west   | 0.315                | 0.1                     | 0.0  | LOS A                  |
|   |            | South-west   | 0.216                | 5.8                     | 0.0  | LOS A                  |
|   |            | <b>Total</b> | <b>0.216</b>         | <b>5.8</b>              | <b>0.0</b>                                 | <b>LOS A</b>           |

Overall, the intersection of Sydenham Road and Buckley Street performs satisfactorily at LOS A. The 95<sup>th</sup> percentile queue lengths are accommodated within the approach distances for all approaches.



## 6.0 Transport interchange monitoring

This section details analysis of the interchange traffic survey data at kerb side facilities nearby station interchanges.

### 6.1 Chatswood Station

In the Chatswood Station study area, a total of five taxi, bus stop and kiss and ride facilities were assessed during Block 1. These included three kiss and ride facilities and two taxi facilities. Refer to **Section 3.3** for detailed information about their locations and the number of bays.

#### Kiss and ride

**Table 6-1** presents a summary of the kiss and ride facilities' peak hour vehicle arrivals and average dwell time. **Figure 6-1** to **Figure 6-3** provide the average dwell time and daily vehicle profile for each of the three kiss and ride facilities. At the CWDK2, it was noted that taxis were waiting at the bay for longer durations to collect passengers for their subsequent trips.

Overall, the kiss and ride bays appear sufficient for the existing demand and no queues form outside the bay.

**Table 6-1 Block 1 – Chatswood Station interchange assessment peak hour summary (kiss and ride)**

| ID                          | Peak hour                    |            |            |           |
|-----------------------------|------------------------------|------------|------------|-----------|
|                             | Summary                      | Weekday AM | Weekday PM | Weekend   |
| CWDK1<br>(Railway Street)   | Peak period                  | 7am-8am    | 7pm-8pm    | 1pm-2pm   |
|                             | Vehicles (vehicle per hour)  | 17         | 17         | 19        |
|                             | Average dwell time (minutes) | 1          | 2          | 2         |
| CWDK2<br>(Albert Avenue)    | Peak period                  | 7am-8am    | 5pm-6pm    | 11am-12pm |
|                             | Vehicles (vehicle per hour)  | 62         | 26         | 24        |
|                             | Average dwell time (minutes) | 1          | 3          | 16        |
| CWDK3<br>(Endeavour Street) | Peak period                  | 8am-9am    | 6pm-7pm    | 12pm-1pm  |
|                             | Vehicles (vehicle per hour)  | 36         | 36         | 23        |
|                             | Average dwell time (minutes) | 2          | 3          | 4         |

*Note: Average dwell times were rounded to the nearest minute.*

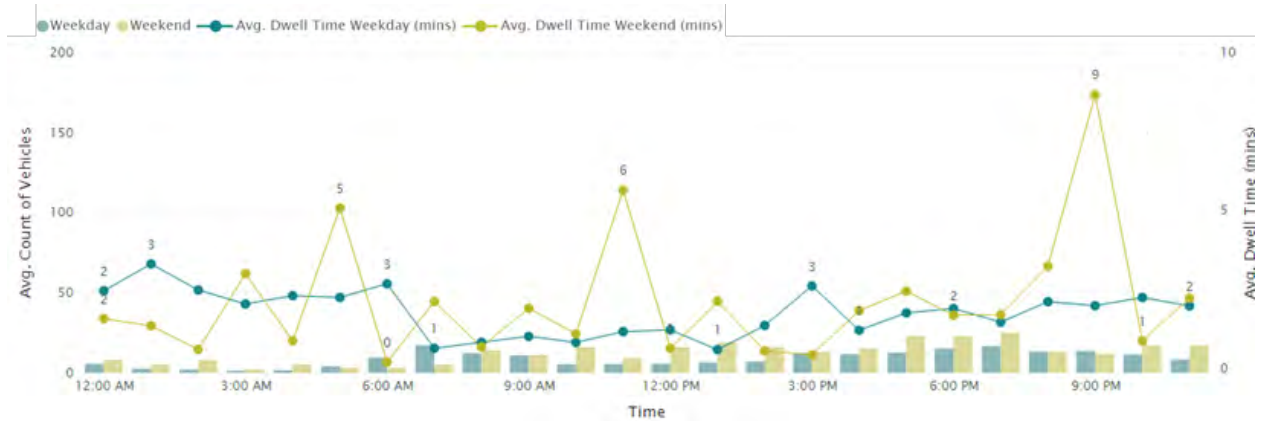

Figure 6-1 Block 1 - average dwell time and daily vehicle profile of CWDK1

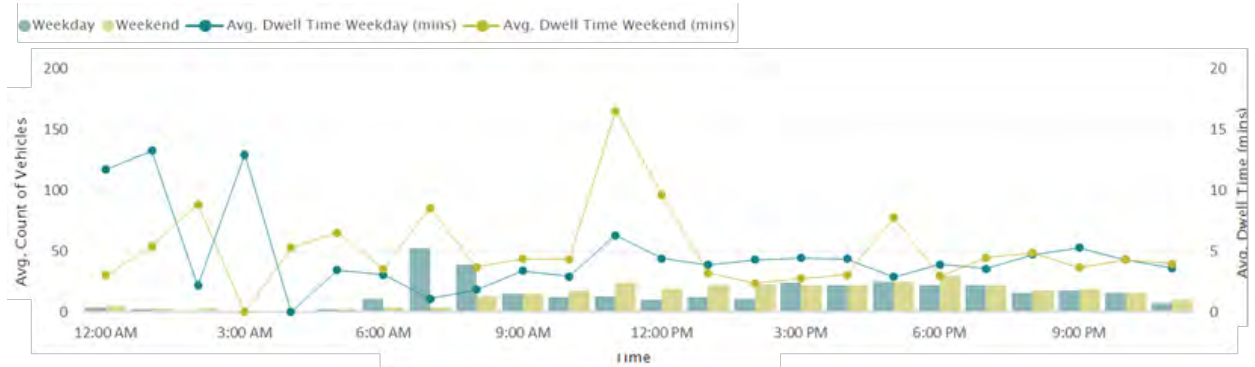

Figure 6-2 Block 1 - average dwell time and daily vehicle profile of CWDK2

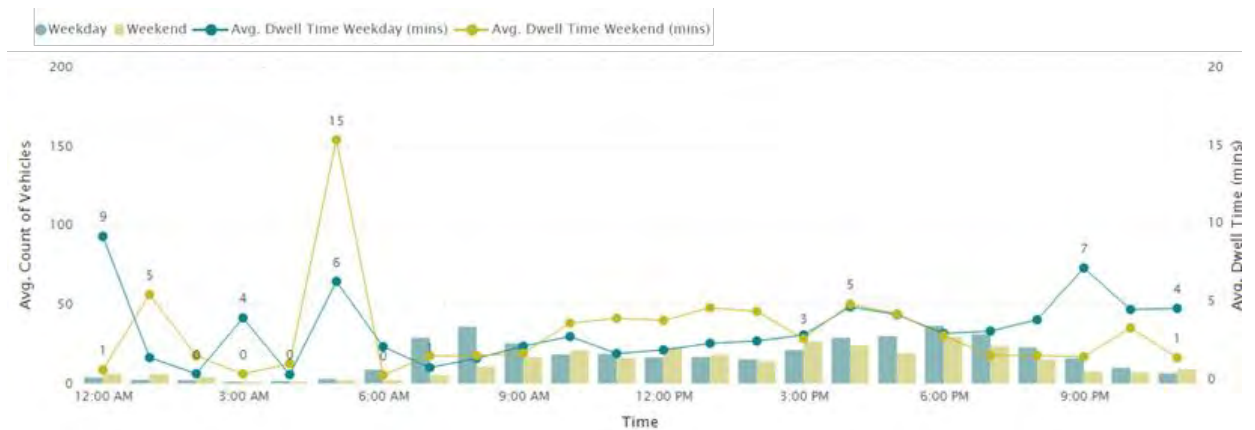

Figure 6-3 Block 1 - average dwell time and daily vehicle profile of CWDK3

Figure 6-4 to Figure 6-9 provide the average daily weekday and weekend boarding and alighting profile for each of the three kiss and ride facilities. Based on the interchange survey data, the following was observed:

- During the weekday:
  - CWDK2 had the highest average daily number of boarding passengers of approximately 20 passengers during the 6pm-7pm peak hour

- CWDK2 had the highest average daily number of alighting passengers of approximately 65 passengers during the 7am-8am peak hour
- During the weekend:
  - CWDK2 had the highest average daily number of boarding passengers of approximately 20 passengers during the 6pm-7pm peak hour
  - CWDK2 had the highest average daily number of alighting passengers of approximately 25 passengers during the 6pm-7pm peak hour

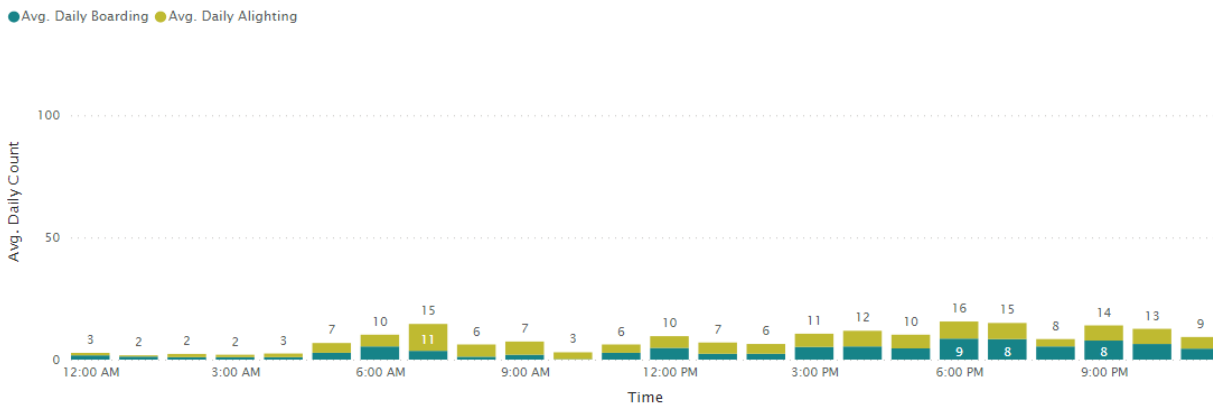

Figure 6-4 Block 1 - average daily boarding and alighting profile for CWDK1 (weekday)

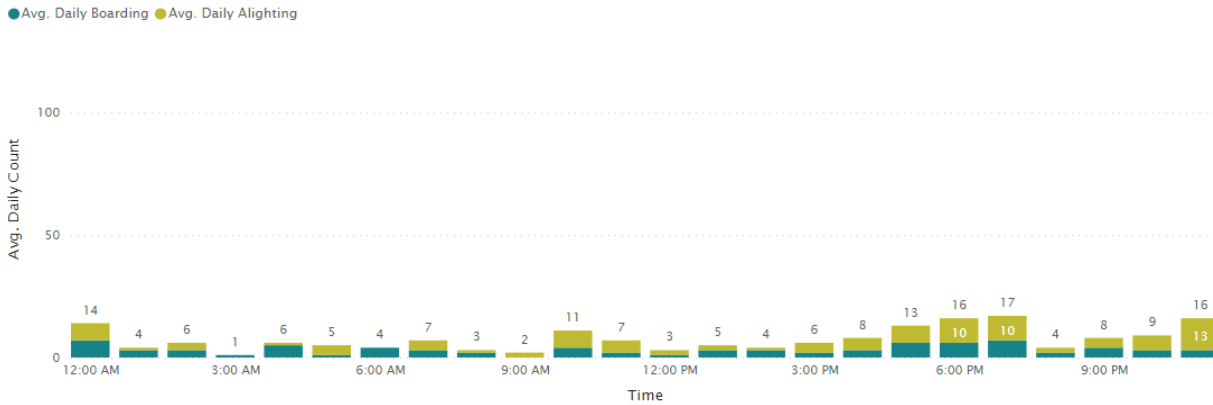

Figure 6-5 Block 1 - average daily boarding and alighting profile for CWDK1 (weekend)

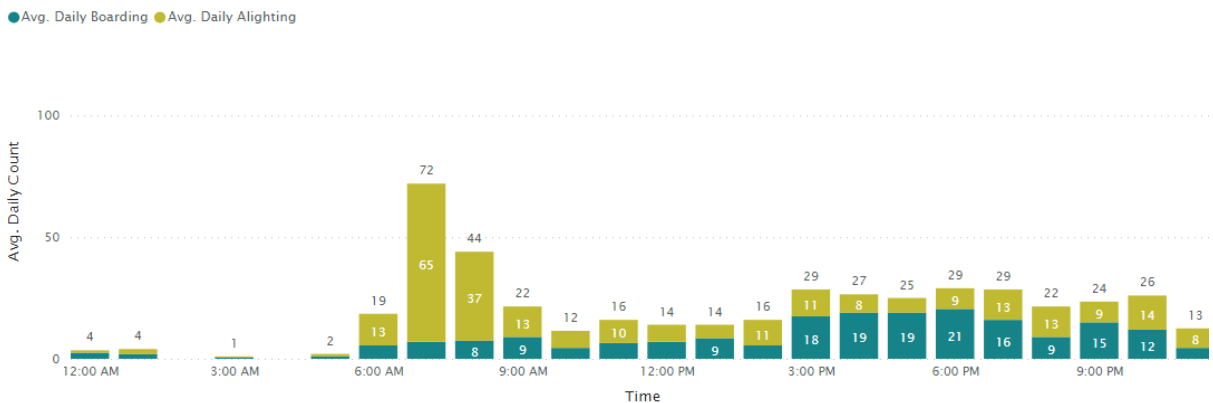

Figure 6-6 Block 1 - average daily boarding and alighting profile for CWDK2 (weekday)

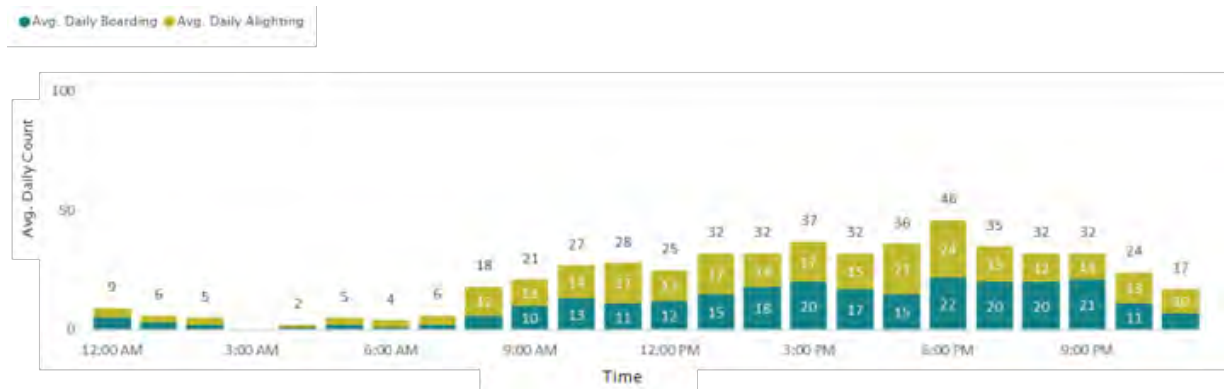

Figure 6-7 Block 1 - average daily boarding and alighting profile for CWDK2 (weekend)

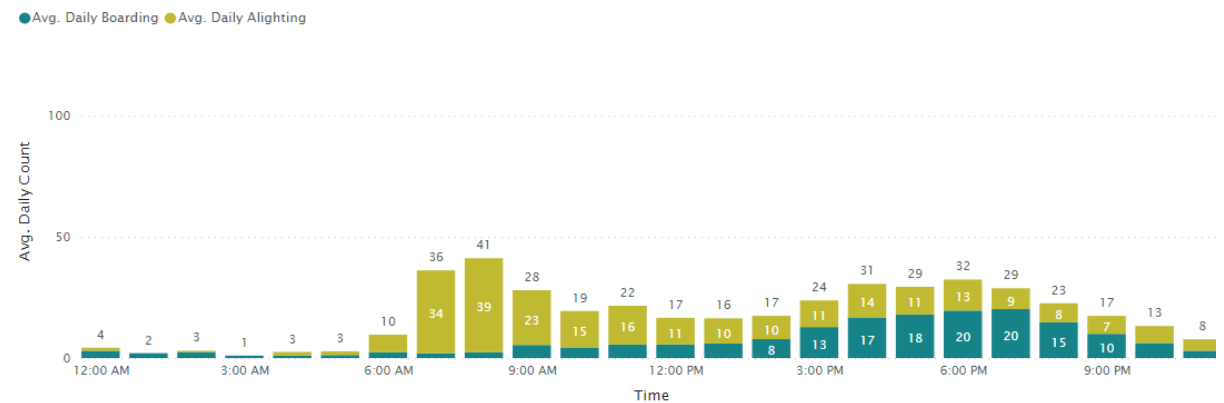

Figure 6-8 Block 1 - average daily boarding and alighting profile for CWDK3 (weekday)

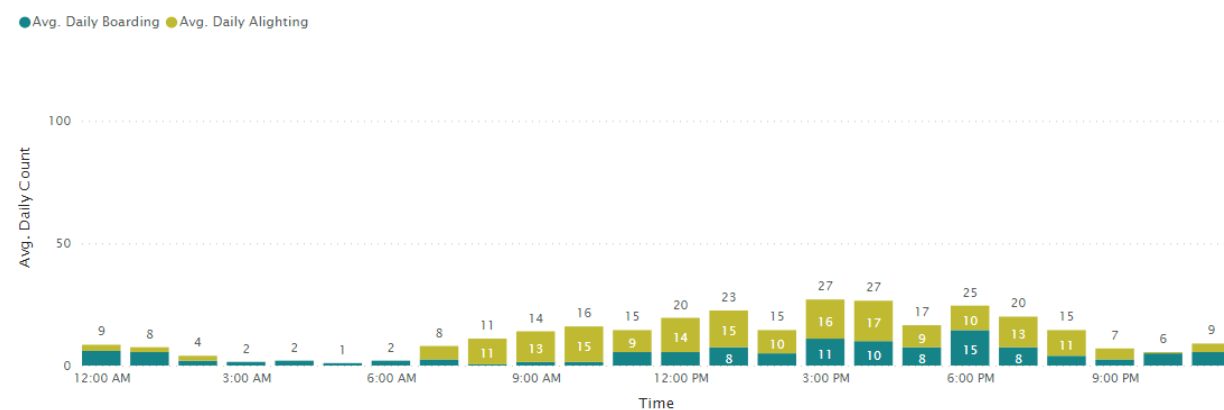

Figure 6-9 Block 1 - average daily boarding and alighting profile for CWDK3 (weekend)

**Taxi**

Table 6-2 presents a summary of the taxi facilities’ peak hour vehicle arrivals and average dwell time. Figure 6-10 and Figure 6-11 and provide the average dwell time and daily vehicle profile for each of the two taxi facilities.

Overall, the taxi bays appear sufficient for the existing demand and no queues form outside the bay. Average dwell times are high due to taxis waiting for passengers.



**Table 6-2 Block 1 - Chatswood Station interchange assessment peak hour summary (taxi)**

| ID                          | Peak hour                    |            |            |          |
|-----------------------------|------------------------------|------------|------------|----------|
|                             | Summary                      | Weekday AM | Weekday PM | Weekend  |
| CWDT1<br>(Victoria Avenue)  | Peak period                  | 9am-10am   | 3pm-4pm    | 1pm-2pm  |
|                             | Vehicles (vehicle per hour)  | 11         | 18         | 13       |
|                             | Average dwell time (minutes) | 14         | 11         | 19       |
| CWDT2<br>(Endeavour Street) | Peak period                  | 9am-10am   | 5pm-6pm    | 12pm-1pm |
|                             | Vehicles (vehicle per hour)  | 4          | 2          | 2        |
|                             | Average dwell time (minutes) | 5          | 56         | 18       |

Note: Average dwell times were rounded to the nearest minute.

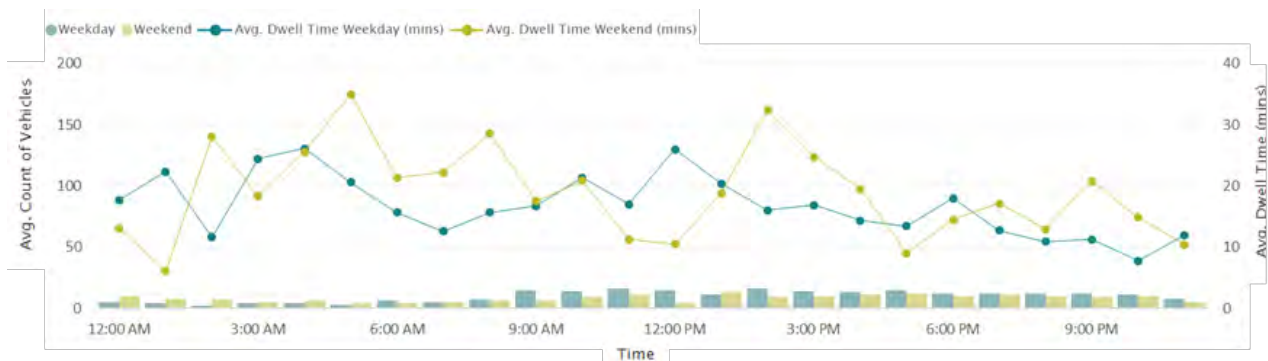

**Figure 6-10 Block 1 - average dwell time and daily vehicle profile of CWDT1**

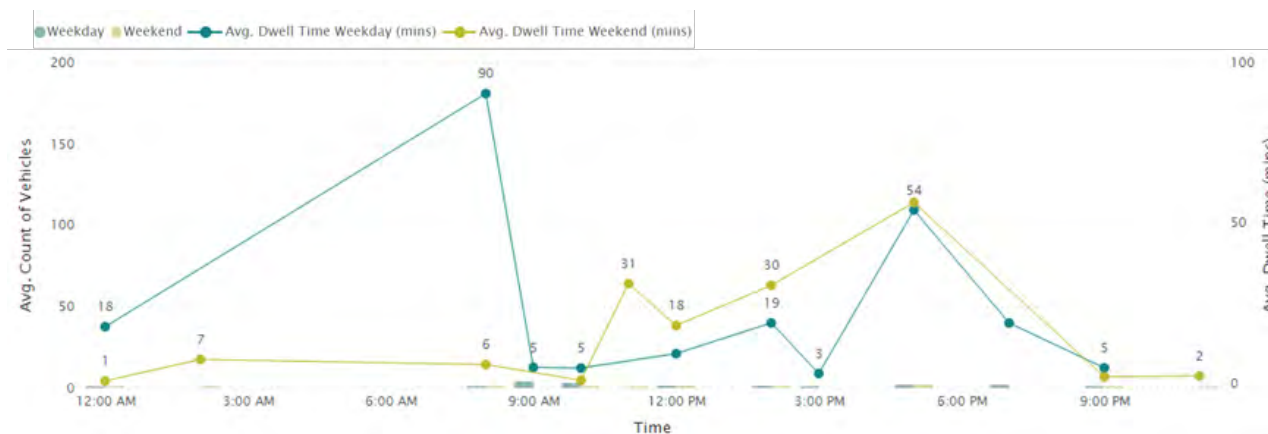

**Figure 6-11 Block 1 - average dwell time and daily vehicle profile of CWDT2**

**Figure 6-12** and **Figure 6-15** provide the average daily weekday and weekend boarding and alighting profile for each of the two taxi facilities. Based on the interchange survey data, the following was observed:

- During the weekday:
  - CWDT1 had the highest average daily number of boarding passengers of approximately 20 passengers during the 11am-12pm peak hour

- CWDT1 had the highest average daily number of alighting passengers of approximately 5 passengers during the 8am-9am peak hour
- During the weekend:
  - CWDT1 had the highest average daily number of boarding passengers of approximately 10 passengers during the 10pm-11pm peak hour
  - CWDT1 had the highest average daily number of alighting passengers of approximately 5 passengers during the 1am-2am peak hour

Avg. Daily Boarding and Alighting

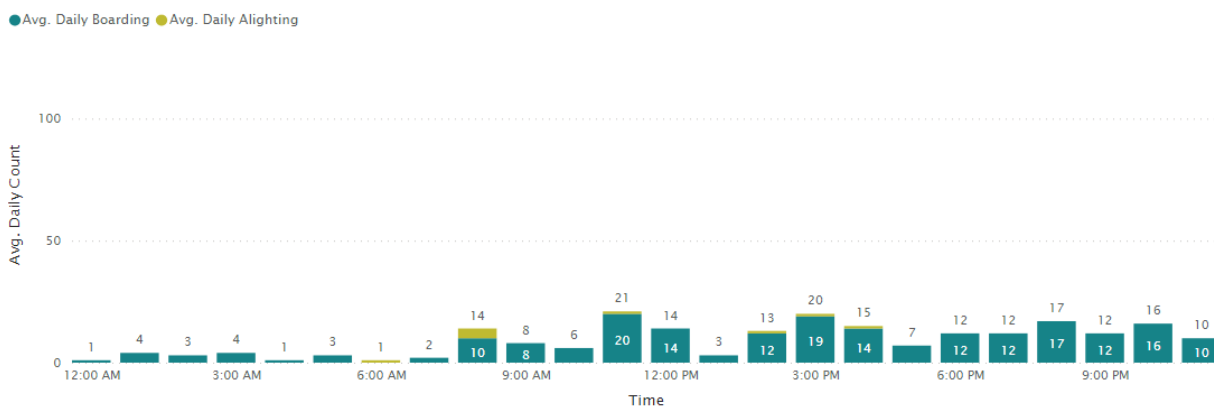

Figure 6-12 Block 1 - average daily boarding and alighting profile for CWDT1 (weekday)

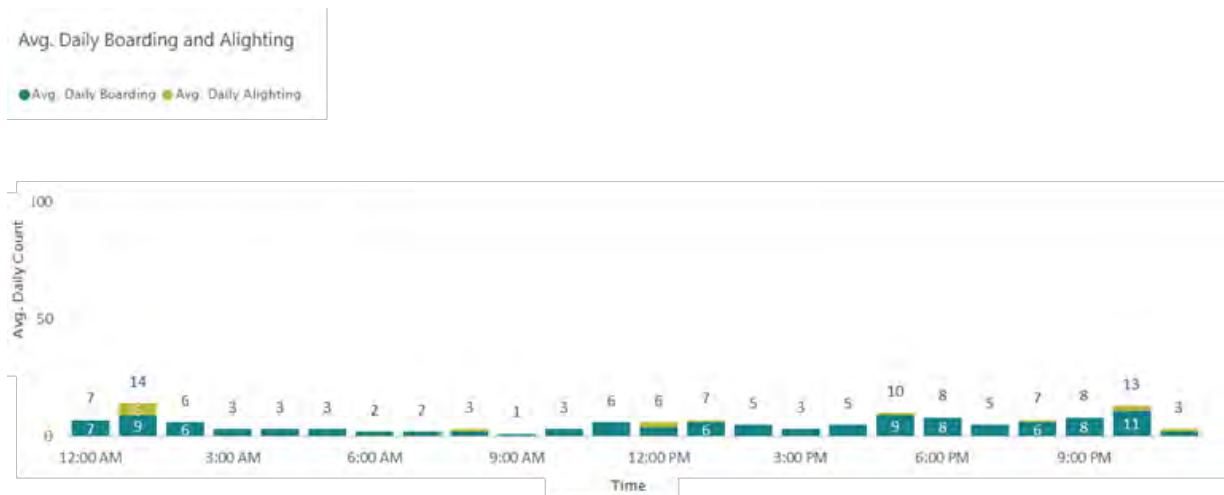

Figure 6-13 Block 1 - average daily boarding and alighting profile for CWDT1 (weekend)

Avg. Daily Boarding and Alighting

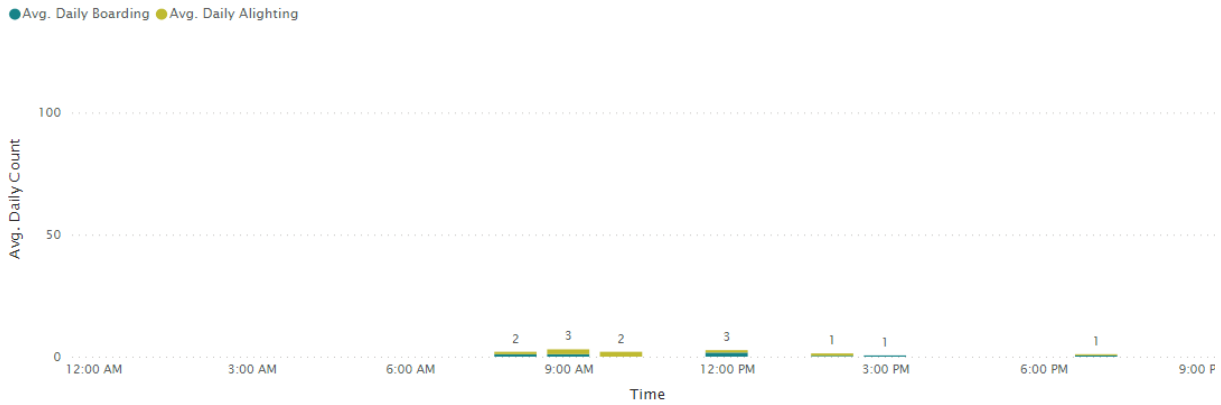

Figure 6-14 Block 1 - average daily boarding and alighting profile for CWDT2 (weekday)

Avg. Daily Boarding and Alighting

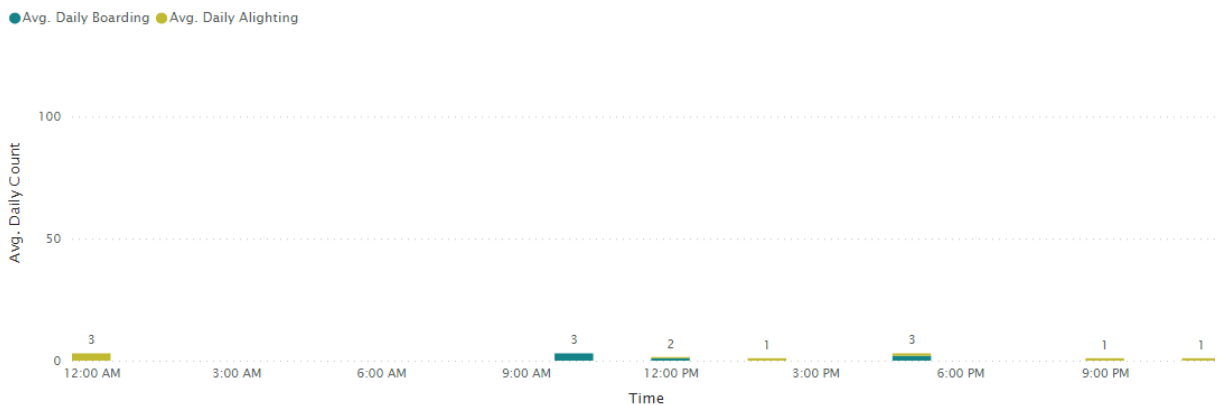

Figure 6-15 Block 1 - average daily boarding and alighting profile for CWDT2 (weekend)

## 6.2 Sydenham Station

In the Sydenham Station study area, a total of five taxi, bus stop and kiss and ride facilities were assessed during Block 1. These included one bus facility, two kiss and ride facilities, one taxi facility and one proposed accessible kiss and ride facility, which operated as an accessible parking space during Block 1. Refer to **Section 3.3** for detailed information about their locations and the number of bays.

### Bus

**Table 6-3** presents a summary of the bus facility peak period vehicle arrival rate and average dwell time. **Figure 6-16** provides the average dwell time and daily vehicle profile for the bus facility.

Overall, no queues were observed outside the bus bays.

Table 6-3 Block 1 - Sydenham Station interchange assessment peak hour summary (bus)

| ID                        | Peak hour                   |            |            |          |
|---------------------------|-----------------------------|------------|------------|----------|
|                           | Summary                     | Weekday AM | Weekday PM | Weekend  |
| SYDB1<br>(Railway Parade) | Peak period                 | 7am-8am    | 5pm-6pm    | 12pm-1pm |
|                           | Vehicles (vehicle per hour) | 16         | 17         | 15       |

| ID | Peak hour                    |            |            |         |
|----|------------------------------|------------|------------|---------|
|    | Summary                      | Weekday AM | Weekday PM | Weekend |
|    | Average dwell time (minutes) | 5          | 3          | 4       |

Note: Average dwell times were rounded to the nearest minute.

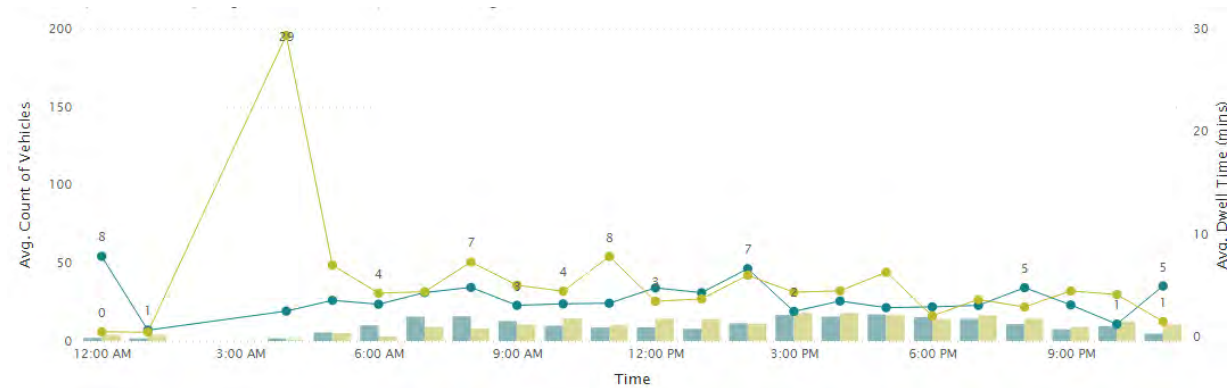

Figure 6-16 Block 1 - average dwell time and daily vehicle profile of SYDB1

Figure 6-17 and Figure 6-18 provide the average daily weekday and weekend boarding and alighting profile for the bus facility. Based on the interchange survey data, the following was observed:

- During the weekday:
  - SYDB1 had the highest average daily number of boarding passengers of approximately 30 passengers during the 7am-8am peak hour
  - SYDB1 had the highest average daily number of alighting passengers of approximately 65 passengers during the 3pm-4pm peak hour.
- During the weekend:
  - SYDB1 had the highest average daily number of boarding passengers of approximately 20 passengers during the 4pm-5pm peak hour
  - SYDB1 had the highest average daily number of alighting passengers of approximately 35 passengers during the 12pm-1pm and 3pm-4pm peak hours.

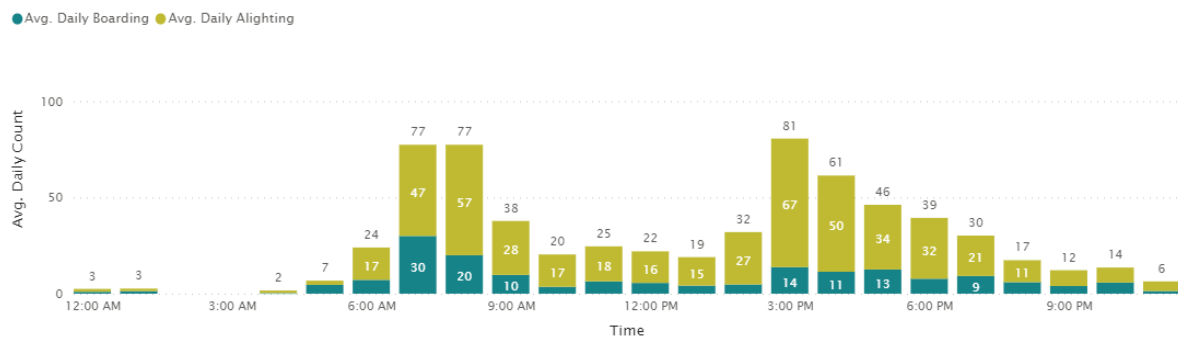

Figure 6-17 Block 1 - average daily boarding and alighting profile for SYDB1 (weekday)



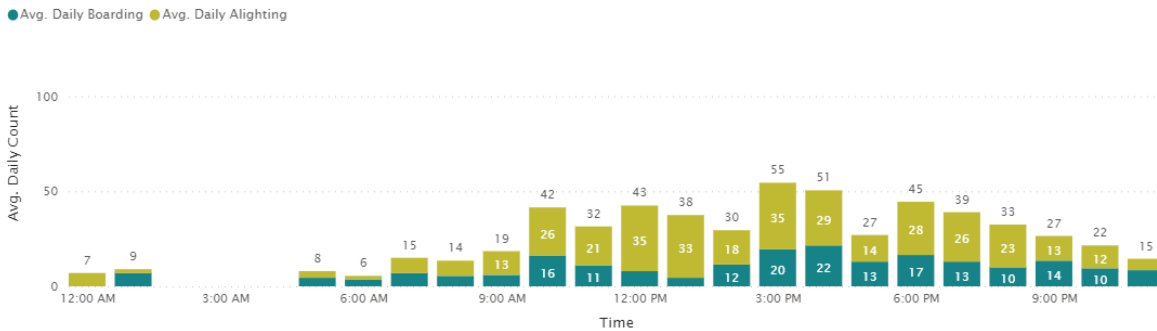

Figure 6-18 Block 1 - average daily boarding and alighting profile for SYDB1 (weekend)

**Kiss and ride**

Table 6-4 presents a summary of the kiss and ride facilities' peak period vehicle arrival rate and average dwell time. Figure 6-19 and Figure 6-20 provide the average dwell time and daily vehicle profile for the kiss and ride facilities.

Overall, the kiss and ride bays appear sufficient for the existing demand and no queues form outside the bays.

Table 6-4 Block 1 - Sydenham Station interchange assessment peak hour summary (kiss and ride)

| ID                        | Peak hour                    |            |            |           |
|---------------------------|------------------------------|------------|------------|-----------|
|                           | Summary                      | Weekday AM | Weekday PM | Weekend   |
| SYDK1<br>(Burrows Avenue) | Peak period                  | 8am-9am    | 5pm-6pm    | 10am-11am |
|                           | Vehicles (vehicle per hour)  | 12         | 17         | 15        |
|                           | Average dwell time (minutes) | 1          | 5          | 5         |
| SYDK2<br>(Sydenham Road)  | Peak period                  | 7am-8am    | 5pm-6pm    | 11am-12pm |
|                           | Vehicles (vehicle per hour)  | 3          | 2          | 1         |
|                           | Average dwell time (minutes) | 3          | 2          | 1         |

Note: Average dwell times were rounded to the nearest minute.

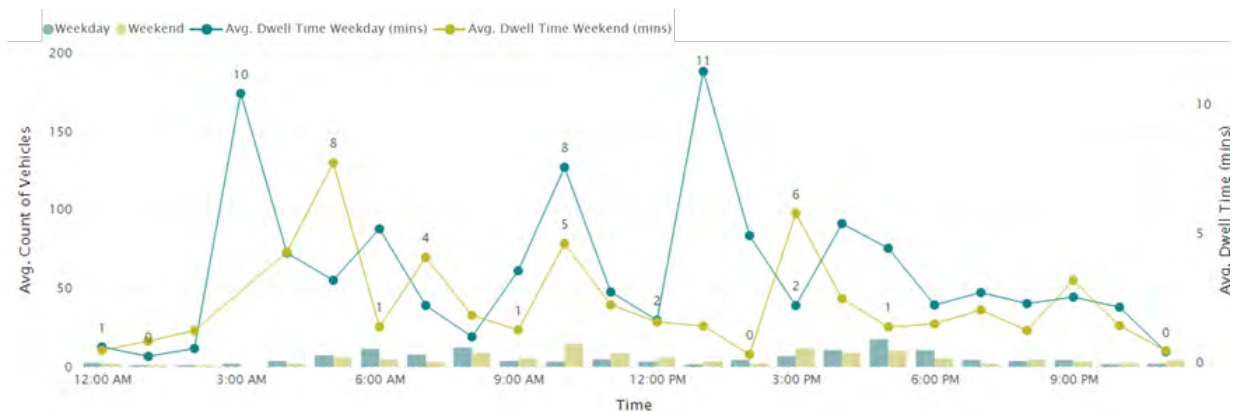

Figure 6-19 Block 1 - average dwell time and daily vehicle profile of SYDK1

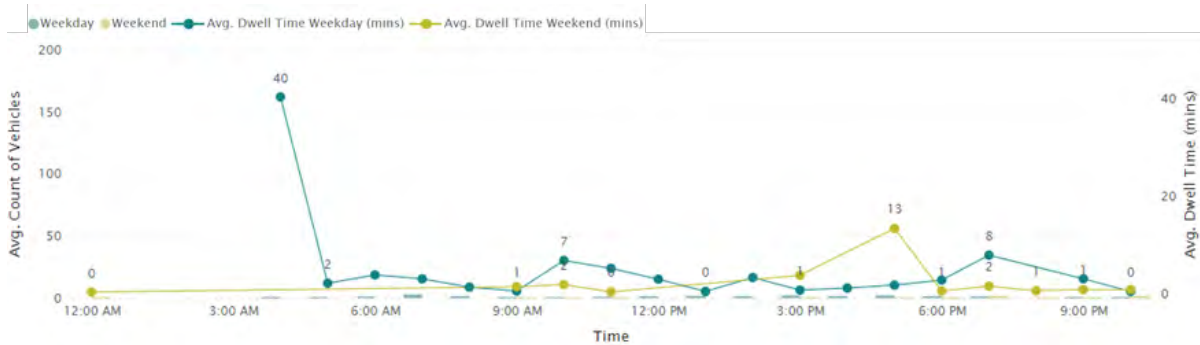

Figure 6-20 Block 1 - average dwell time and daily vehicle profile of SYDK2

Figure 6-21 to Figure 6-24 provide the average daily weekday and weekend boarding and alighting profile for each of the two kiss and ride facilities. Based on the interchange survey data, the following was observed:

- During the weekday:
  - SYDK1 had the highest average daily number of boarding passengers of approximately 15 passengers during the 5pm-6pm peak hour
  - SYDK1 had the highest average daily number of alighting passengers of approximately 10 passengers during the 6am-7am peak hour
- During the weekend:
  - SYDK1 had the highest average daily number of boarding passengers of approximately 10 passengers during the 3pm-4pm and 5pm-6pm peak hours
  - SYDK1 had the highest average daily number of alighting passengers of approximately 10 passengers during the 10am-11am peak hour

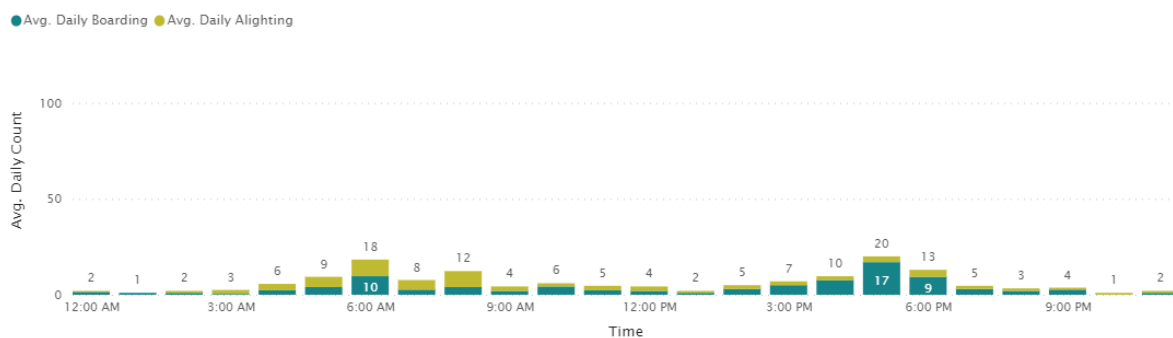

Figure 6-21 Block 1 - average daily boarding and alighting profile for SYDK1 (weekday)

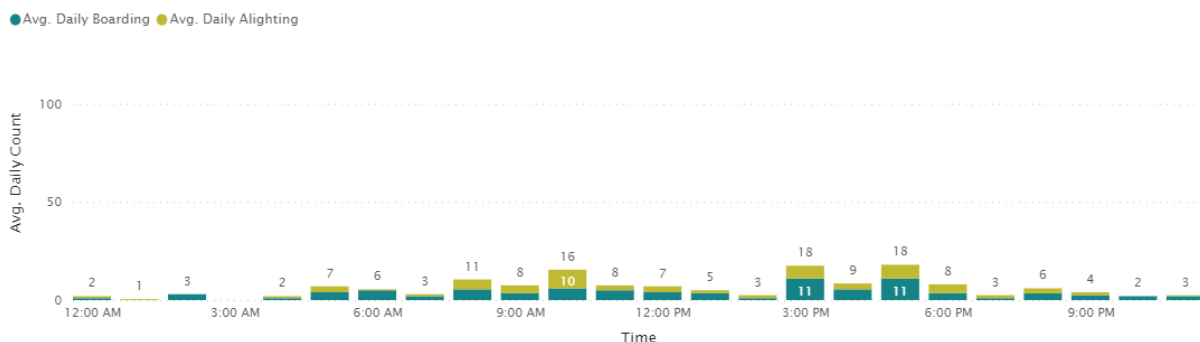

Figure 6-22 Block 1 - average daily boarding and alighting profile for SYDK1 (weekend)

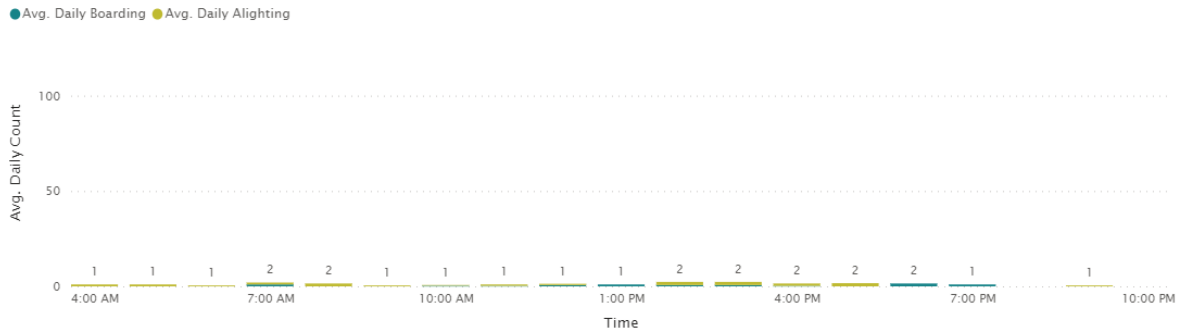

Figure 6-23 Block 1 - average daily boarding and alighting profile for SYDK2 (weekday)

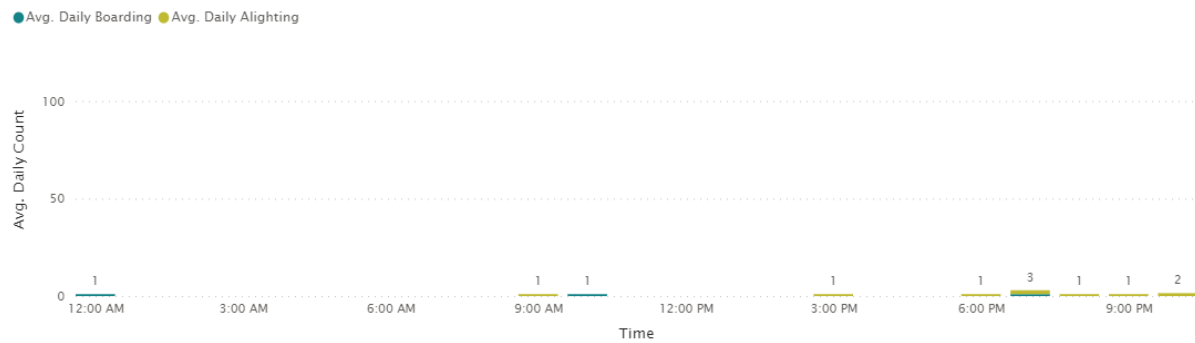

Figure 6-24 Block 1 - average daily boarding and alighting profile for SYDK2 (weekend)

**Taxi**

Table 6-5 presents a summary of the taxi facility peak period vehicle arrival rate and average dwell time. Figure 6-25 provides the average dwell time and daily vehicle profile for the taxi facility.

During the site visits, a lower number of taxis were observed using the designated taxi rank, while the majority of taxis were seen utilising the existing kiss and ride bays.

Table 6-5 Block 1 - Sydenham Station interchange assessment peak hour summary (taxi)

| ID                        | Peak hour                    |            |            |         |
|---------------------------|------------------------------|------------|------------|---------|
|                           | Summary                      | Weekday AM | Weekday PM | Weekend |
| SYDT1<br>(Burrows Avenue) | Peak period                  | 9am-10am   | 5pm-6pm    | 1pm-2pm |
|                           | Vehicles (vehicle per hour)  | 1          | 2          | 1       |
|                           | Average dwell time (minutes) | 2          | 9          | 11      |

Note: Average dwell times were rounded to the nearest minute.

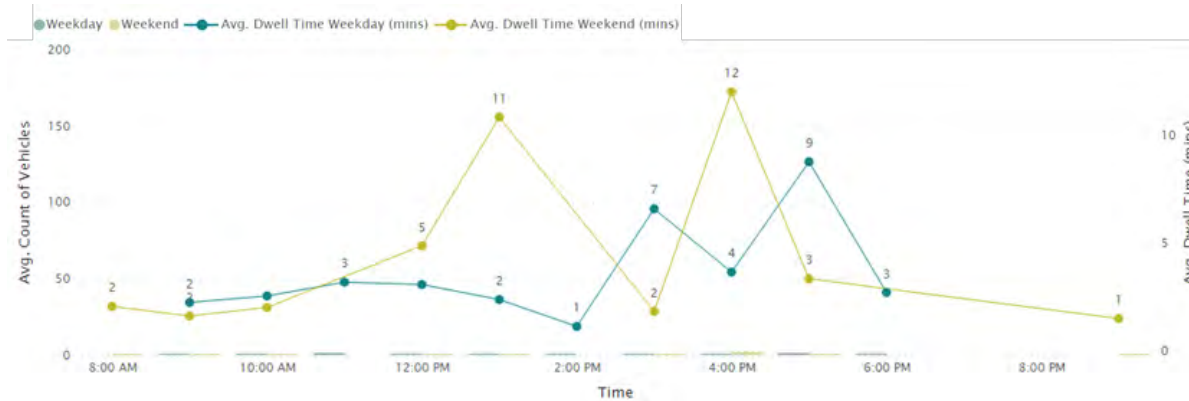

Figure 6-25 Block 1 - average dwell time and daily vehicle profile of SYDT1

Figure 6-26 and Figure 6-27 provide the average daily weekday and weekend boarding and alighting profile for the taxi facility. Based on the interchange survey data, the average daily passenger boarding and alighting numbers were found to be relatively low. Throughout both weekdays and weekends, there were on average up to two passenger boardings, and up to three passenger alightings recorded during the survey period.

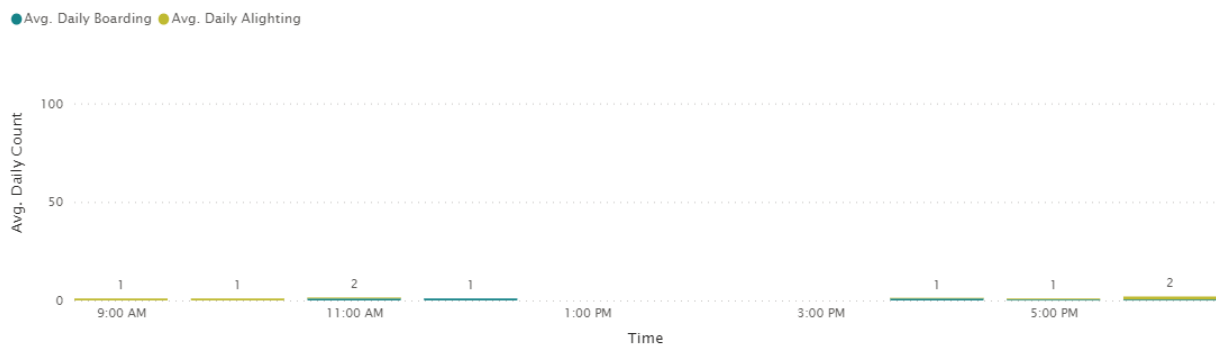

Figure 6-26 Block 1 - average daily boarding and alighting profile for SYDT1 (weekday)

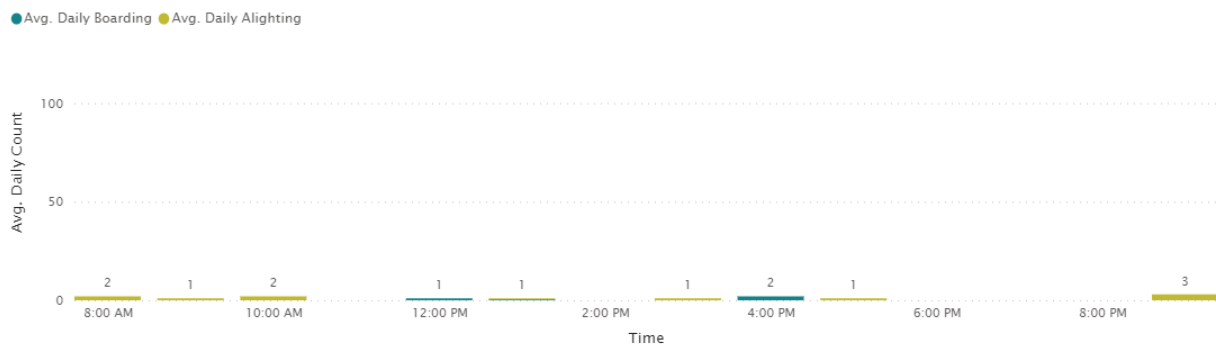

Figure 6-27 Block 1 - average daily boarding and alighting profile for SYDT1 (weekend)

**Accessible kiss and ride**

Table 6-6 presents a summary of the accessible kiss and ride facility peak period vehicle arrival rate and average dwell time. Figure 6-28 provides the average dwell time and daily vehicle profile for the access kiss and ride facility.

High dwell times were observed in the weekday AM peak due to a parked vehicle in the kiss and ride bay.



**Table 6-6 Block 1 - Sydenham Station interchange assessment peak hour summary**

| ID                       | Peak hour                    |            |            |          |
|--------------------------|------------------------------|------------|------------|----------|
|                          | Summary                      | Weekday AM | Weekday PM | Weekend  |
| SYDA1<br>(Bolton Street) | Peak period                  | 10am-11am  | 5pm-6pm    | 12pm-1pm |
|                          | Vehicles (vehicle per hour)  | 1          | 2          | 1        |
|                          | Average dwell time (minutes) | 111        | 5          | 2        |

Note: Average dwell times were rounded to the nearest minute.

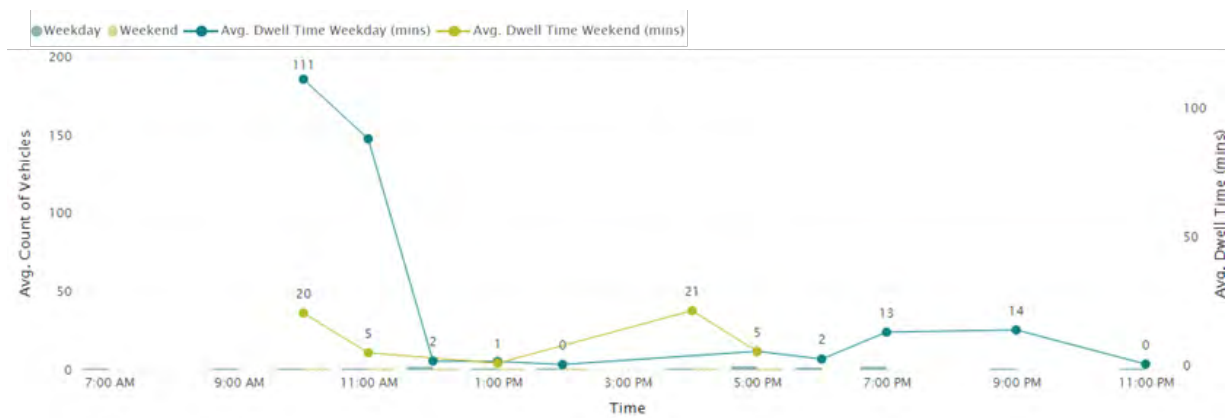

**Figure 6-28 Block 1 - average dwell time and daily vehicle profile of SYDA1**

**Figure 6-29** and **Figure 6-30** provide the average daily weekday and weekend boarding and alighting profile for the accessible kiss and ride facility. Based on the interchange survey data, the average daily passenger boarding and alighting numbers were found to be relatively low. Throughout both weekdays and weekends, there were on average up to two passenger boardings, and up to two passenger alighting recorded during the survey period. However, an exception was seen during the weekend peak hour of 12pm-1am, which had on average five boarding and five alighting passenger numbers.

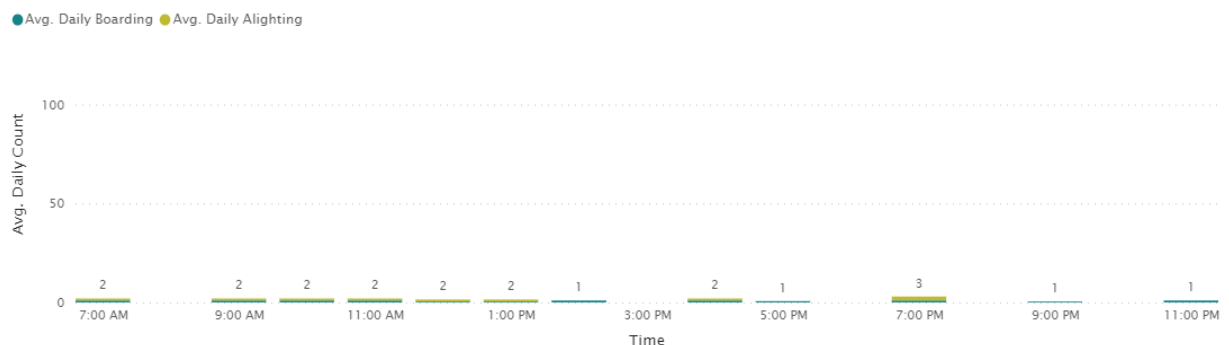

**Figure 6-29 Block 1 - average daily boarding and alighting profile for SYDA1 (weekday)**

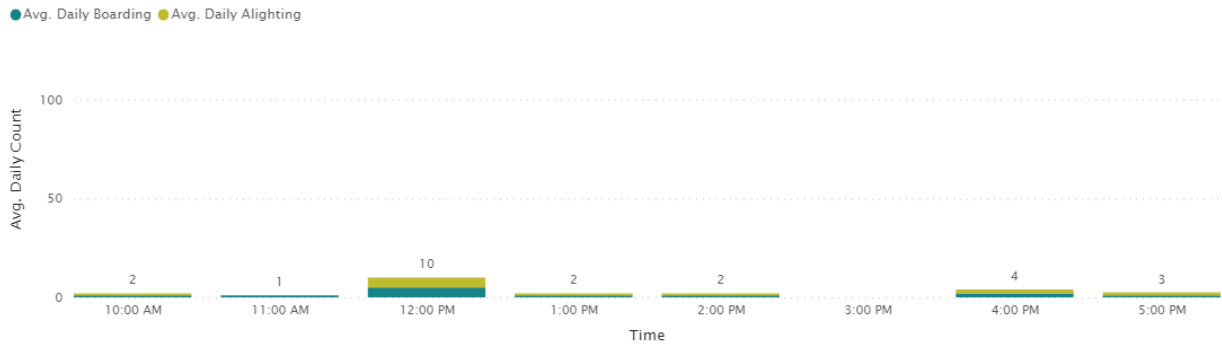

Figure 6-30 Block 1 - average daily boarding and alighting profile for SYDA1 (weekend)

## 7.0 Summary

AECOM Australia Pty Ltd (AECOM) has been commissioned by Sydney Metro to perform traffic and interchange monitoring assessments for the Sydney Metro City & Southwest, covering the stretch between Chatswood Station and Sydenham Station (the Project).

The primary objective of the traffic and interchange monitoring assessment is to evaluate the potential impacts of metro operations at the nine stations along the Sydney Metro City & Southwest (Chatswood to Sydenham) on the surrounding intersections and interchange facilities.

To meet the CoA requirements and align with the project program for Sydney Metro City & Southwest (Chatswood to Sydenham), the traffic and interchange monitoring program will be conducted in six study blocks. The monitoring period will span 12 months before the commencement of CSSI operations (pre-opening) and another 12 months after the commencement (post-opening).

The overall scope of works for the Block 1 study covers the following:

- **Traffic monitoring:** Intersection surveys were conducted during three periods - late-March 2023, early-April 2023, and early-May 2023 (re-surveys). The surveys included classified intersection count survey and vehicular queue length survey.
- **Transport interchange monitoring:** Only Chatswood Station and Sydenham Station were considered for the interchange monitoring for the Block 1 study due to the existing operational train/metro stations. Interchange operation surveys were conducted at these two stations continuously for a one-week period in March 2023.
- **Site visit and observations:** Site visits were undertaken in conjunction with the traffic and interchange operation monitoring for at least one weekday AM peak, one weekday PM peak, and one weekday peak period at each station.
- **Intersection assessment:** To evaluate the intersection operation during Block 1, isolated and network traffic modelling assessments were performed using SIDRA Intersection modelling software (SIDRA Intersection).
- **Traffic and interchange monitoring report:** The key findings of the Block 1 study were presented to Sydney Metro and key stakeholders in July 2023. This report provides a summary of the details regarding the Block 1 traffic and interchange operation assessment.

Key findings of the Block 1 study are:

- **Intersection monitoring:** Based on site observation and SIDRA Intersection modelling results, intersection operation and performance of key intersections at each station are summarised as follows.
  - Chatswood Dive Site:
    - The intersection of Mowbray Road and Hampden Road (CWD01) performs at LOS B or better during all peak hours.
    - At the intersection of Mowbray Road and Hampden Rodd (CWD01), Mowbray Road (east approach) experiences consistent congestion and the queue extends close to the intersection with Elizabeth Street during all peak hours.
  - Crows Nest Station:
    - All intersections within the Crows Nest Station study area perform at LOS C or better during all peak hours, except the Pacific Highway, Falcon Street and Shirley Road intersection (CST04) performs at LOS D during the AM peak hour.
    - The intersections at Pacific Highway and Albany Street intersection (CST01) and Pacific Highway, Falcon Street and Shirley Road (CST04) experiences queues which extend to one or more approaches of the adjacent intersection at peak hours.
  - Victoria Cross Station:

- All intersections within the Victoria Cross Station study area operate at LOS C or better during all peak hours.
- Barangaroo Station:
  - All intersections within the Barangaroo Station study area operate at LOS C or better during all peak hours.
  - Queuing at the western approach of the Kent Street and King Street intersection (BGU15) extends back to Sussex Street during the weekday AM peak hour.
- Martin Place Station:
  - All intersections within the Martin Place Station study area operate at LOS C or better during all peak hours.
- Pitt Street Station:
  - All intersections within the Pitt Street Station study area operate at LOS B or better during all peak hours.
  - At the intersection of Park Street and Castlereagh Street (PIT03), queuing on Park Street (east approach) extend back to Elizabeth Street during all peak hours.
- Central Station:
  - All intersections within the Central Station study area operate at LOS C or better during all peak hours.
- Waterloo Station:
  - All intersections within the Waterloo Station study area operate at LOS C or better during all peak hours.
  - Queuing at the eastern approach of the Botany Road, Raglan Street and Henderson Road intersection (WLO01) extends back to the intersection of Raglan Street and Cope Street during all peak hours.
- Sydenham Station:
  - All intersections within the Sydenham Station study area operate at LOS B or better during all peak hours.
  - Queuing along Gleeson Avenue at the intersection of Burrows Avenue and Gleeson Avenue (SYD02) extends back closer to the slip lane of the Railway Parade and Gleeson Avenue intersection during all peak hours.
- **Transport interchange monitoring:** The interchange operation surveys focused on analysing taxi, bus stop and kiss and ride facilities at Chatswood Station and Sydenham station. The Key findings are summarised as follows.
  - Chatswood Station:
    - The provision of kiss and ride bays and taxi bays were sufficient and cater for the existing demand, with no queues forming outside the bays
  - Sydenham Station:
    - The provision of kiss and ride bays appears sufficient for the existing demand, no queues form outside the bay

In summary, the results from Block 1 traffic and interchange monitoring demonstrate generally satisfactory intersection performance, consistently achieving LOS C or better across all stations, except for CST04. Furthermore, the assessment of kiss and ride and taxi facilities at Chatswood and Sydenham stations indicates their sufficient provision.

To ensure a comprehensive and reliable monitoring assessment across all six blocks, the findings from the Block 1 study will serve as a baseline for comparative analysis in the subsequent blocks.



# Appendix A

## Stakeholder Meeting Minutes

Appendix A Stakeholder Meeting Minutes

# Minutes of Meeting

## Sydney Metro City & Southwest - Traffic and Interchange Operation Monitoring

|              |   |      |                   |
|--------------|---|------|-------------------|
| Subject      | Block 1 Presentation - TfNSW  | Page | 1                 |
| Venue        | MS-Teams  | Time | 10:00am - 11:00am |
| Participants | Garry Hitchcox (GH), Sydney Metro<br>Nita Hutapea (NH), Sydney Metro<br>Kedar Ballurkar (KB), Sydney Metro<br>Carl Mella (CM), TfNSW<br>Chris Slenders (CS), TfNSW<br>Anoop Sridhar (AS), AECOM<br>Padmanaban Subramanian (PS), AECOM |      |                   |
| Apologies    | Maryam Yadak (MY), TfNSW  |      |                   |
| File/Ref No. | SM-C&SW-MM-003  | Date | 28-Jul-2023       |
| Distribution | As above  |      |                   |

| No | Item  | Action | Date |
|----|---|--------|------|
| 1. | <p><b>Introduction</b></p> <ul style="list-style-type: none"> <li>NH commenced the meeting providing a brief overview of the project including the stakeholder consultations conducted on late 2022.</li> <li>Attendees introduced themselves, highlighting their roles and organisations.</li> <li>Meeting commenced with an Acknowledgement of Country.</li> </ul>  |        |      |
| 2. | <p><b>Project Overview and Results</b></p> <ul style="list-style-type: none"> <li>AS presented the outcomes of Block 1 monitoring for the intersections and interchanges located within the Block 1 study area for the traffic monitoring study of the proposed Sydney Metro City &amp; Southwest (C&amp;SW) line.</li> <li>CM enquired on the high dwell time observed on the SYHA1. AS explained that the extended dwell time resulted from cars parked for longer periods at this location. It was clarified that this site is designated as a proposed Kiss and Ride area but is currently being used as accessible parking.</li> <li>GH enquired whether there are parking restrictions at this location. <i>Post Meeting Note: Survey footage and site visit photos have been reviewed and it is observed that accessible parking is permitted at this location with some parking restrictions at selected time periods.</i></li> </ul> |        |      |

| No | Item   | Action   | Date |
|----|--|--|------|
|    | <ul style="list-style-type: none"> <li>• CM commented that the Block 1 monitoring results look good for most intersections.</li> <li>• CM enquired about the reasoning behind proposing more intersections for Barangaroo Station compared to Pitt Street and Martin Place. NH explained that during stakeholder discussions, it was discussed that Barangaroo Station has a greater number of construction sites, particularly along Hickson Road, and there might be revised traffic patterns in both pre-opening and post-opening scenarios. On the other hand, Pitt Street and Martin Place would have only minimal changes to the existing road network.</li> <li>• CS highlighted that intersections within the CBD experience significant pedestrian activities. If future assessments show a decline in the pedestrian Level of Service (LoS), appropriate mitigations must be taken into account for future planning.</li> <li>• CM enquired whether the raw survey data is available for individual intersections. AS responded that the survey data is available broken down into individual turning movements for each study intersections.</li> <li>• NH presented an outline of the suggested alternative program for the upcoming blocks and sought feedback and concerns from TfNSW regarding the timeframes and sequencing of the proposed changes. CS and CM acknowledged that the revised proposal seems acceptable and advised that this needs to be checked internally to gather feedback before confirming.</li> </ul> | <p>CS and CM to check and confirm acceptance of the proposed program</p> |      |

**Enclosures:**

- Block 1 Presentation



# Minutes of Meeting

## Sydney Metro City & Southwest - Traffic and Interchange Operation Monitoring

|              |  |      |                   |
|--------------|--|------|-------------------|
| Subject      | Block 1 Presentation   | Page | 1                 |
| Venue        | MS-Teams   | Time | 02:30pm - 03:30pm |
| Participants | Garry Hitchcox (GH), Sydney Metro<br>Nita Hutapea (NH), Sydney Metro<br>Kedar Ballurkar (KB), Sydney Metro<br>Michael Huy (MH), Inner West Council<br>George Tsaprounis (GT), Inner West Council<br>Allan Borg (AB), Inner West Council<br>Kendall Banfield (KBN), Inner West Council<br>Minas Kassiou (MK), Inner West Council<br>Anoop Sridhar (AS), AECOM<br>Padmanaban Subramanian (PS), AECOM |      |                   |
| Apologies    |  |      |                   |
| File/Ref No. | SM-C&SW-MM-002   | Date | 27-Jul-2023       |
| Distribution | As above   |      |                   |

| No | Item   | Action                    | Date |
|----|--|---------------------------|------|
| 1. | <b>Introduction</b> <ul style="list-style-type: none"> <li>NH commenced the meeting providing a brief overview of the project including the stakeholder consultations conducted on late 2022.</li> <li>Attendees introduced themselves, highlighting their roles and organisations.</li> <li>Meeting commenced with an Acknowledgement of Country.</li> </ul>  |                           |      |
| 2. | <b>Project Overview and Results</b> <ul style="list-style-type: none"> <li>AS presented the outcomes of Block 1 monitoring for the intersections and interchanges located within the Inner West Council area for the traffic monitoring study of the proposed Sydney Metro City &amp; Southwest (C&amp;SW) line.</li> <li>MK inquired whether the surveys were conducted outside the school holidays. AS responded that all the surveys were conducted outside the school/public holidays.</li> <li>MH asked whether the information presented for the total pedestrians crossing is for a single intersection or all intersections. AS clarified that the information is for all the intersections within the Sydenham station study area.</li> </ul> | Sydney Metro to provide a |      |

| No | Item  | Action   | Date |
|----|---|--|------|
|    | <ul style="list-style-type: none"> <li>• GT inquired whether the survey raw data and a copy of the presentation will be provided to the council. NH confirmed that Sydney Metro will be providing them.</li> <li>• AB inquired whether this study considers the bus replacement services when the metro line opens. NH responded that the Rail Replacement Services are not considered as part of this study and are being addressed in a separate study.</li> <li>• KBN inquired whether pedestrian safety is part of the EIS Conditions of Approval (D12). NH responded that the Conditions of Approval for this study only discuss the traffic monitoring, and the inclusion of pedestrian safety is not explicitly specified. This study follows a similar approach to the traffic monitoring conducted for the existing Northwest metro line (Chatswood to Tallawong).</li> <li>• KBN and GT also added that the pedestrian zebra crossings at Buckley St (SYD05 &amp; SYD06) have ongoing safety issues due to a high number of pedestrians, despite implementing some safety measures at these sites based on discussions with TfNSW. KBN highlighted that pedestrian flows may increase in the future due to new developments and the opening of Sydney Metro C&amp;SW line, which might worsen the situation further. NH replied that the SIDRA analysis currently includes the surveyed pedestrian flows, and the Sydney Metro C&amp;SW post-opening scenarios may be able to capture the impacts of increased pedestrian volumes. If the analysis indicates a worse level of performance, suitable mitigation measures will be identified in future blocks.</li> <li>• NH provided an overview of the proposed alternative program for the upcoming blocks and inquired whether the Inner West Council has any feedback and concerns on the timeframes and sequencing of the proposed changes. GT responded that the Inner West Council agrees with the proposed changes to the future monitoring blocks.</li> </ul> | <p>copy of the presentation and the raw data</p> |      |

**Enclosures:**

- Block 1 Presentation

# Minutes of Meeting

## Sydney Metro City & Southwest - Traffic and Interchange Operation Monitoring

|              |   |      |                   |
|--------------|---|------|-------------------|
| Subject      | Block 1 Presentation for Willoughby City Council  | Page | 1                 |
| Venue        | MS-Teams  | Time | 02:00pm - 03:00pm |
| Participants | Garry Hitchcox (GH), Sydney Metro<br>Nita Hutapea (NH), Sydney Metro<br>Kedar Ballurkar (KB), Sydney Metro<br>Daniel Sui (DS), Willoughby City Council<br>John Gill (JG), Willoughby City Council<br>Dennis Nguyen (DN), Willoughby City Council<br>Ian Shillington (IS), Willoughby City Council<br>Aston Pei (AP), Willoughby City Council<br>Adeline Sim (ASi), Willoughby City Council<br>Anoop Sridhar (AS), AECOM<br>Padmanaban Subramanian (PS), AECOM |      |                   |
| Apologies    |   |      |                   |
| File/Ref No. | SM-C&SW-MM-001  | Date | 26-Jul-2023       |
| Distribution | As above  |      |                   |

| No | Item  | Action | Date |
|----|---|--------|------|
| 1. | <b>Introduction</b> <ul style="list-style-type: none"> <li>Attendees introduced themselves, highlighting their roles and organisations.</li> <li>Meeting commenced with an Acknowledgement of Country.</li> </ul>   |        |      |
| 2. | <b>Project Overview and Results</b> <ul style="list-style-type: none"> <li>DS enquired about the rationale behind the selection of intersection and interchanges for the station assessment methodology. NH explained that the intersections and interchanges were selected based on stakeholder discussions conducted prior to the traffic monitoring and with consideration for potential project impacts (i.e. intersections were considered for monitoring if any changes were proposed as part of this project).</li> <li>DS asked why Traffic Monitoring of intersections is not required for Chatswood Station. AS explained this is because there are no changes to the road network arising from the City &amp; Southwest (C&amp;SW) project,</li> </ul> |        |      |



| No | Item  | Action   | Date |
|----|---|--|------|
|    | <p>however the D12 study have included Interchange Monitoring for Chatswood Station.</p> <ul style="list-style-type: none"> <li>• DS asked whether there is additional information available related to the origin and destination of pedestrian and cyclists movements. AS replied that this project scope only covers the pedestrian and cyclists crossing the intersections.</li> <li>• DS enquired whether any future forecasts related to pedestrian and cyclists patronage and traffic modes accessing the metro stations are available and requested if it can be shared. NH responded that that the forecasts are available in the Interchange Access Plans (IAPs) and the associated forecasts can be shared with Willoughby City Council (WCC). DS asked if there any plans to upgrade the amenities (parking bays, cycle racks) at the Chatswood station due to the increased patronage resulting from the City &amp; Southwest (C&amp;SW) metro line. NS and GH explained that there are not much changes in patronage are expected in the Chatswood Metro Station post opening of C&amp;SW metro line, since this is currently serves as transfer terminal between the existing Northwest metro line and the T1 Sydney Trains line. In future, once the C&amp;SW metro line opens, customers on the NW line can effectively stay on the Metro train to city stations. GH also highlighted the changes to travel patterns for public transport post-covid which might have an impact and highlighted that if potential changes are observed, then Sydney Metro could liaise with WCC for further discussions.</li> <li>• DS enquired whether the presentation can be shared with the WCC councillors and whether the project team is willing to accommodate any potential follow up presentations with the councillors. GH responded that Sydney Metro has no concerns in sharing this presentation with WCC councillors.</li> <li>• NH provided the closing comments that Block 1 would serve as a base case and there could be potential increase in vehicles, pedestrians and cyclists in future blocks.</li> <li>• NH also provided an overview of the proposed alternative program for the upcoming blocks and enquired whether WCC has any feedback and concerns on the timeframes and sequencing of the proposed changes to shift Block 2 to Oct/Nov and Block 3 to when C&amp;SW commences next year. DS responded</li> </ul> | <p>Sydney Metro to share IAP and available pedestrian and cyclists forecast data</p> |      |

| No | Item   | Action   | Date |
|----|--|--|------|
|    | <p>that there are no concerns for the proposed changes to the monitoring blocks.</p> <ul style="list-style-type: none"> <li>• DS asked whether the Chatswood Dive Site operations at Mowbray Road are being completed and the construction traffic will be reduced in the coming months. GH advised that construction activities are wrapping up at this site and Department of Education will take possession to develop an adjacent site.</li> <li>• DS enquired whether the proposed C&amp;SW metro opening date is confirmed. GH responded the proposed date around April 2024 is based on current assumptions and subject to change, however the actual date will be communicated to major stakeholders.</li> </ul> | <p>Sydney Metro to provide the updated slide deck to WCC</p> |      |

**Enclosures:**

- Block 1 Presentation

# Appendix B

## SIDRA Intersection Modelling Assumptions

## Appendix B SIDRA Intersection Modelling Assumptions

## Technical Assumptions and Outputs Memo

### 1.0 Traffic and Interchange monitoring data outputs

The following outputs are proposed to be provided for the traffic and interchange monitoring:

- Weekly profile graph for individual intersections for 24hr period.
- Summary of daily total traffic volumes per intersection/interchange in a tabular format.
- Weekly profile graph for each station (total of all intersections) for 24hr period.
- Summary of daily total traffic volumes for each station (total of all intersections) in a tabular format.
- Graph of total traffic flows of intersection for typical peak periods during weekdays (06:00-10:00 am and 03:00-07:00 pm) and weekends (10:00am - 02:00pm).
- Turning movements for identified peak hours during weekdays AM and PM peaks and weekend peaks in a network flow diagram in excel spreadsheets.
- Pedestrian volumes for identified peak hours during weekdays AM and PM peaks and weekend peaks in a network diagram in excel spreadsheets.
- Vehicle counts for 7-day weekly profile, typical peak periods, identified peaks for interchanges to include:
  - Vehicle counts for each bay
  - Vehicle occupancy (passenger only, driver excluded)
  - Vehicle dwell time for each bay
  - Vehicle queue length (outside the bay)

### 2.0 SIDRA modelling related assumptions

Table 1 outlines technical assumptions that will be applied for SIDRA modelling analysis.

**Table 1 SIDRA Modelling Assumptions**

| SI No. | Parameter                             | Assumption   |
|--------|---------------------------------------|--|
| 1.     | SIDRA Software Version                | SIDRA 9.1  |
| 2.     | Lane Configuration - Grade            | A default 0% grade will be applied to all lanes / TCS plans where applicable.                                    |
| 3.     | Lane Width                            | A default 3.3m lane width will be applied to all lanes.  |
| 4.     | Approach / Exit Cruise Speed          | Based on posted speed limit. A default speed of 50km/h will be adopted where posted speed limit is not enforced. |
| 5.     | Roundabout Entry Radius & Entry Angle | A default entry radius of 20m and a default entry angle of 30 degrees will be adopted for all roundabouts.       |
| 6.     | Critical Gap & Follow-up Headway      | The default 'Program' input will be adopted for all movements.   |
| 7.     | Gap Acceptance                        | The default 'SIDRA Standard' gap acceptance capacity model will be adopted for all vehicle types.                |



| SI No. | Parameter   | Assumption  |
|--------|---|---|
|        |   | Reference will also be made to relevant standards/requirements in Austroads (RMS Modelling Guidelines), where applicable.   |
| 8.     | Vehicle Movement Start Loss & End Gain            | Based on SCATS data provided and survey footages / site observations  |
| 9.     | Pedestrian Walking Speed (Average)                | 1.2 m/s   |
| 10.    | Pedestrian Crossing Distance                      | Based on intersection geometry/Program (TCS plan where available / Nearmap aerial imageries)  |
| 11.    | Peak Flow Period                                  | 30 minutes  |
| 12.    | Peak Flow Factor                                  | 95%   |
| 13.    | Phasing Arrangements                              | Based on SCATS data provided  |
| 14.    | Phase Time and Frequency                          | Based on SCATS data provided  |
| 15.    | Yellow Time & All-Red Time                        | Based on SCATS data provided  |
| 16.    | Site Cycle/phase Time                             | User-Given Phase Time (Based on Phase time & frequency)   |
| 17.    | Maximum Number of Iterations for Network Analysis | A default 30 iterations will be adopted. Increases of the maximum number of iterations may be applied depending on the Diagnostics Status.  |
| 18.    | Network Cycle Time                                | User-Given Cycle Time (Based on User-Given Phase Time for all signals within the network)   |
| 19.    | Network Signal Coordination                       | Coordinated Sites / User offsets / CCGs will be defined based on SCATS data provided. Signal offsets included in the SIDRA models provided by Sydney Metro will be adopted where relevant SCATS data are not available. |
| 20.    | Queue in Outputs (Site & Network)                 | 95th Percentile   |
| 21.    | PCU factor  | LV: 1.0, HV & Bus: 2.0, Bicycles: 0.3   |
| 22.    | Site level of service method                      | Delay (RTA NSW)   |
| 23.    | Extra Bunching (Site Analysis)                    | Based on RMS Traffic Modelling Guidelines   |
| 24.    | Movement Classes                                  | Based on each intersection geometry (LV, HV, Buses, Bicycles)   |
| 25.    | All other parameters                              | Default SIDRA settings  |

The following additional assumptions will be adopted for SIDRA modelling based on the discussion with Sydney Metro on 04 Apr 2023.

**Table 2 Additional SIDRA Modelling Assumptions**

| SI No. | Items              | Assumption  |
|--------|--------------------|---|
| 1.     | Network peak hours | For each station, peak hours will be identified for individual intersections and proposed networks (highlighted in green cells in Figure 1). By reviewing these individual and network peak hours, a station-wide peak hour will be nominated/adopted for each peak period. Peak period dates will be identified for each station |

| SI No. | Items                              | Assumption  |
|--------|------------------------------------|---|
|        |                                    | for AM, PM and weekend. For eg.SYD AM Peak - Tuesday; SYD PM Peak - Thursday; WLO AM Peak - Wednesday   |
| 2.     | Cyclist movements                  | For SIDRA modelling, cyclist movements will only be included if there is a dedicated cycling phase.   |
| 3.     | Intersection approach/lane closure | Due to construction activities, some approaches/lanes were observed temporarily (partially) closed on site. These temporary closures will be reflected in the models unless it only occurs for a short period of time (for e.g. 10 to 15mins). Notes will be made to approach/lane closure observed on-site, and approach/lane excluded in SIDRA modelling. |
| 4.     | CST06 intersection geometry        | Hume St North (one-way exit) will not be included in Block 1 modelling.<br>Notes will be made to the left turn movements observed from Clarke St northwest to Hume St north.  |
| 5.     | BGU05 intersection geometry        | Clarence St northbound on-ramp lane to SHB will not be included in the modelling.   |
| 6.     | CEN03/CEN05 intersection geometry  | Elizabeth St/Randle St intersection has been included as CEN05, and will be modelled as network model with CEN03.   |

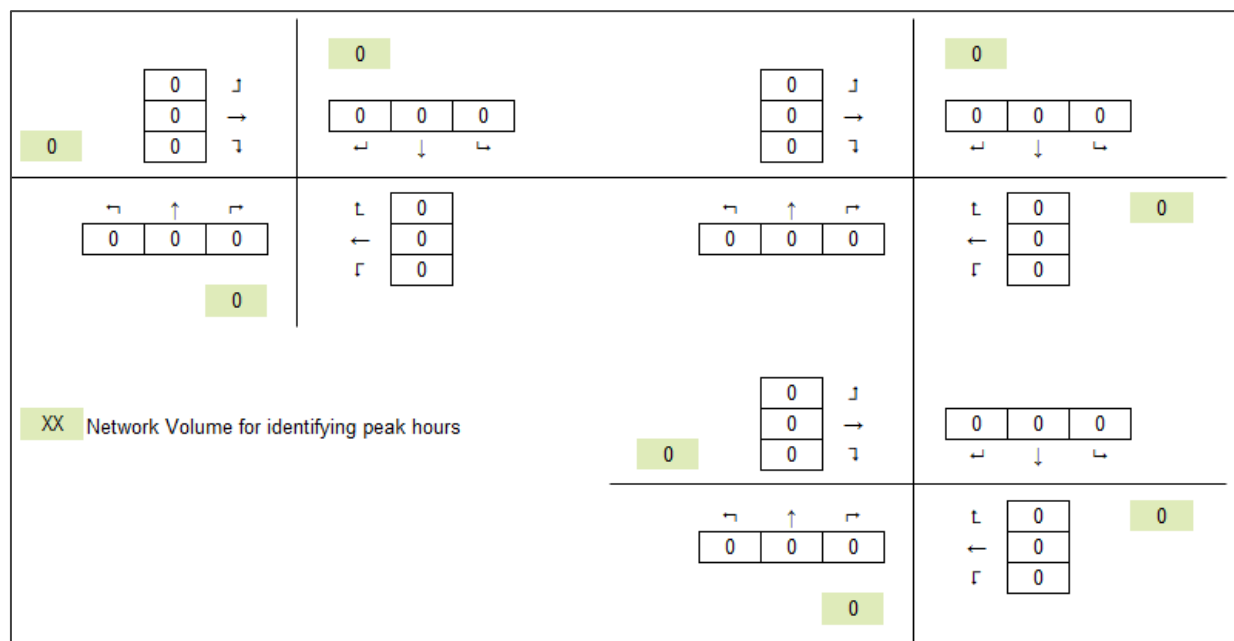

Figure 1 Adopted Network Volume for Network Peak Hour Identification

The following SIDRA outputs would be provided for each intersection.

- Degree of saturation (DoS)
- Average delay (sec)
- 95th percentile queue (m)
- Level of service (LoS)

A sample format of the output table is shown in Table 3.

**Table 3 Example SIDRA output format**

| Intersection                                      | Peak    | Leg   | Degree of saturation (DoS) | Average delay (sec) | 95 <sup>th</sup> percentile queue (m) | Level of service (LoS) |
|---|---------|-------|----------------------------|---------------------|---------------------------------------|------------------------|
| Road1 / Road2<br>(Signal / Roundabout / Priority) | AM      | South |                            |                     |                                       |                        |
|   |         | East  |                            |                     |                                       |                        |
|   |         | North |                            |                     |                                       |                        |
|   |         | West  |                            |                     |                                       |                        |
|   |         | Total |                            |                     |                                       |                        |
|   | PM      | South |                            |                     |                                       |                        |
|   |         | East  |                            |                     |                                       |                        |
|   |         | North |                            |                     |                                       |                        |
|   |         | West  |                            |                     |                                       |                        |
|   |         | Total |                            |                     |                                       |                        |
|   | Weekend | South |                            |                     |                                       |                        |
|   |         | East  |                            |                     |                                       |                        |
|   |         | North |                            |                     |                                       |                        |
|   |         | West  |                            |                     |                                       |                        |
|   |         | Total |                            |                     |                                       |                        |

## Sydney Metro City & Southwest - Traffic and Interchange Operation Monitoring

SIDRA Network Model Coverage

| S.ID | Intersection ID | Station Name           | Intersection Name  | Intersection Control              | Intersection Geometry Layout  | Intersection Geometry Code | SIDRA Network Model (AECOM Revised) Pre-opening | Coordination  |
|------|-----------------|------------------------|--|-----------------------------------|-------------------------------|----------------------------|---|---------------|
| 01   | CWD01           | Chatswood Station      | Mowbray Rd / Hampden Rd  | Signal                            | 3-leg Intersection            | 2_4_6                      | -   | -             |
| 02   | CWD02           | Chatswood Station      | Pedestrian Bridge Crossing along Mowbray                                     | Pedestrian only - Bridge Crossing | Bridge Crossing               | 2_6                        | -   | -             |
| 03   | CST01           | Crows Nest Station     | Pacific Hwy / Albany St  | Signal                            | 3-leg Intersection            | 3_4_8                      | CST-N1  | Offset_CST-N1 |
| 04   | CST02           | Crows Nest Station     | Pacific Hwy / Oxley St   | Signal                            | 4-leg Intersection            | 2_4_6_8                    | CST-N1  | Offset_CST-N1 |
| 05   | CST03           | Crows Nest Station     | Pacific Hwy / Hume St  | Signal                            | 4-leg Intersection            | 2_4_6_8                    | CST-N1  | Offset_CST-N1 |
| 06   | CST04           | Crows Nest Station     | Pacific Hwy / Falcon St / Shirley Rd   | Signal                            | 5-leg Intersection            | 1_3_4_6_8                  | CST-N1  | Offset_CST-N1 |
| 07   | CST05           | Crows Nest Station     | Clarke St / Oxley St   | Priority - Give Way               | 3-leg Intersection            | 1_4_6                      | CST-N1  | -             |
| 08   | CST06           | Crows Nest Station     | Clarke St / Hume St  | Priority - Give Way               | 3-leg Intersection            | 4_6_8                      | CST-N1  | -             |
| 09   | CST07           | Crows Nest Station     | Clarke St / Willoughby Rd  | Priority - Give Way               | 3-leg Intersection            | 1_5_7                      | -   | -             |
| 10   | CST08           | Crows Nest Station     | Albany St / Willoughby Rd  | Signal                            | 4-leg Intersection            | 1_3_5_7                    | -   | -             |
| 11   | CST09           | Crows Nest Station     | Albany St / Oxley St   | Roundabout                        | 4-leg Intersection            | 1_3_5_7                    | CST-N1  | -             |
| 12   | CST10           | Crows Nest Station     | Albany St / Clarke Ln  | Priority - Give Way               | 3-leg Intersection            | 3_4_7                      | CST-N1  | -             |
| 13   | CST11           | Crows Nest Station     | Oxley St / Clarke Ln   | Priority - Give Way               | 4-leg Intersection            | 2_4_6_8                    | CST-N1  | -             |
| 14   | CST12           | Crows Nest Station     | Hume St / Clarke Ln  | Priority - Stop                   | 3-leg Intersection            | 2_4_6                      | CST-N1  | -             |
| 15   | CST13           | Crows Nest Station     | Pacific Hwy / Alexander St   | Signal                            | 4-leg Intersection            | 1_3_4_8                    | CST-N1  | Offset_CST-N1 |
| 16   | CST14           | Crows Nest Station     | Falcon St / Alexander St   | Signal                            | 4-leg Intersection            | 1_3_5_7                    | CST-N1  | Offset_CST-N1 |
| 17   | VIC01           | Victoria Cross Station | Pacific Hwy / Berry St   | Signal                            | 4-leg Intersection            | 3_4_6_8                    | VIC-N1  | Offset_VIC-N1 |
| 18   | VIC02           | Victoria Cross Station | Miller St / Berry St   | Signal                            | 4-leg Intersection            | 1_3_5_7                    | VIC-N1  | Offset_VIC-N1 |
| 19   | VIC03           | Victoria Cross Station | Miller St / McLaren St   | Signal                            | 4-leg Intersection            | 1_3_5_7                    | VIC-N1  | -             |
| 20   | VIC04           | Victoria Cross Station | Pacific Hwy / Miller St  | Signal                            | 5-leg Intersection            | 1_4_5_7_8                  | VIC-N1  | Offset_VIC-N1 |
| 21   | BGU01           | Barangaroo Station     | Hickson Rd / Towns Pl  | Priority - Give Way               | 3-leg Intersection            | 3_6_8                      | BGU-N1  | -             |
| 22   | BGU02           | Barangaroo Station     | Dalgely Rd / Towns Pl  | Roundabout                        | 3-leg Intersection            | 4_5_7                      | BGU-N1  | -             |
| 23   | BGU03           | Barangaroo Station     | Kent St / Argyle St  | Priority - Give Way               | 4-leg Intersection            | 1_3_5_7                    | -   | -             |
| 24   | BGU04           | Barangaroo Station     | Pedestrian Mid-block Crossing at Kent St near Gas Ln                         | Pedestrian only - Signal          | Pedestrian Mid-block Crossing | 1_5                        | BGU-N2  | Offset_BGU-N2 |
| 25   | BGU05           | Barangaroo Station     | Kent St / Sydney Harbour Bridge (SHB) On-ramp                                | Signal                            | 4-leg Intersection            | 1_2_3_5                    | BGU-N2  | Offset_BGU-N2 |
| 26   | BGU06           | Barangaroo Station     | Hickson Rd / Napoleon St / Sussex St   | Signal                            | 4-leg Intersection            | 1_3_5_7                    | BGU-N3  | -             |
| 27   | BGU07           | Barangaroo Station     | Margaret St / Kent St / Napoleon St  | Signal                            | 4-leg Intersection            | 1_3_5_8                    | BGU-N2  | Offset_BGU-N2 |
| 28   | BGU08           | Barangaroo Station     | Margaret St / Clarence St  | Signal                            | 4-leg Intersection            | 1_3_5_7                    | BGU-N2  | Offset_BGU-N2 |
| 29   | BGU09           | Barangaroo Station     | Margaret St / York St  | Signal                            | 4-leg Intersection            | 1_3_5_7                    | BGU-N2  | -             |
| 30   | BGU10           | Barangaroo Station     | Pedestrian Mid-block Crossing at Sussex St under Exchange Pl                 | Pedestrian only - Signal          | Pedestrian Mid-block Crossing | 1_5                        | BGU-N3  | -             |
| 31   | BGU11           | Barangaroo Station     | Pedestrian Mid-block Crossing at Kent St near Margaret St                    | Pedestrian only - Signal          | Pedestrian Mid-block Crossing | 1_5                        | BGU-N3  | -             |
| 32   | BGU12           | Barangaroo Station     | Sussex St / Erskine St   | Signal                            | 4-leg Intersection            | 1_3_5_7                    | BGU-N3  | Offset_BGU-N3 |
| 33   | BGU13           | Barangaroo Station     | Kent St / Erskine St   | Signal                            | 4-leg Intersection            | 1_3_5_7                    | BGU-N3  | Offset_BGU-N3 |
| 34   | BGU14           | Barangaroo Station     | Sussex St / King St  | Signal                            | 4-leg Intersection            | 1_3_5_6                    | BGU-N4  | Offset_BGU-N4 |
| 35   | BGU15           | Barangaroo Station     | Kent St / King St  | Signal                            | 4-leg Intersection            | 1_3_5_7                    | BGU-N4  | Offset_BGU-N4 |
| 36   | BGU16           | Barangaroo Station     | New Pedestrian Mid-block Crossing at New Hickson Rd (north of Metro Station) | Pedestrian only - Signal          | Pedestrian Mid-block Crossing | 1_5                        | -   | -             |
| 37   | BGU17           | Barangaroo Station     | New Pedestrian Mid-block Crossing at New Hickson Rd (south of Metro Station) | Pedestrian only - Signal          | Pedestrian Mid-block Crossing | 1_5                        | -   | -             |
| 38   | BGU18           | Barangaroo Station     | Shelley St / Erskine St  | Signal                            | 4-leg Intersection            | 1_3_5_7                    | BGU-N3  | -             |
| 39   | MPL01           | Martin Place Station   | Hunter St / Castlereagh St / Bligh St  | Signal                            | 4-leg Intersection            | 1_3_5_8                    | MPL-N1  | Offset_MPL-N1 |
| 40   | MPL02           | Martin Place Station   | Hunter St / Elizabeth St / Chifley Square                                    | Signal                            | 4-leg Intersection            | 2_3_5_7                    | MPL-N1  | Offset_MPL-N1 |
| 41   | MPL03           | Martin Place Station   | Bent St / Bligh St   | Signal                            | 3-leg Intersection            | 4_6_8                      | MPL-N1  | Offset_MPL-N1 |
| 42   | MPL04           | Martin Place Station   | Bent St / Phillip St   | Signal                            | 4-leg Intersection            | 1_4_6_8                    | MPL-N1  | Offset_MPL-N1 |
| 43   | MPL05           | Martin Place Station   | Pedestrian Mid-block Crossing at Castlereagh St                              | Pedestrian only - Signal          | Pedestrian Mid-block Crossing | 1_5                        | -   | -             |
| 44   | MPL06           | Martin Place Station   | Pedestrian Mid-block Crossing at Elizabeth St                                | Pedestrian only - Signal          | Pedestrian Mid-block Crossing | 1_5                        | -   | -             |
| 45   | PIT01           | Pitt Street Station    | Pitt St / Bathurst St  | Signal                            | 4-leg Intersection            | 1_3_5_7                    | PIT-N1  | -             |
| 46   | PIT02           | Pitt Street Station    | Castlereagh St / Bathurst St   | Signal                            | 4-leg Intersection            | 1_3_5_7                    | PIT-N1  | -             |
| 47   | PIT03           | Pitt Street Station    | Park St / Castlereagh St   | Signal                            | 4-leg Intersection            | 1_3_5_7                    | PIT-N1  | -             |
| 48   | PIT04           | Pitt Street Station    | Park St / Pitt St  | Signal                            | 4-leg Intersection            | 1_3_5_7                    | PIT-N1  | -             |
| 49   | CEN01           | Central Station        | Elizabeth St / Eddy Ave  | Signal                            | 3-leg Intersection            | 1_5_8                      | CEN-N1  | Offset_CEN-N1 |
| 50   | CEN02           | Central Station        | Elizabeth St / Foveaux St  | Signal                            | 3-leg Intersection            | 1_4_5                      | CEN-N1  | Offset_CEN-N1 |
| 51   | CEN03           | Central Station        | Elizabeth St / Cooper St   | Priority - Give Way               | 3-leg Intersection            | 1_4_5                      | CEN-N2  | -             |
| 52   | CEN04           | Central Station        | New Pedestrian Mid-block Crossing at Randle Ln                               | Pedestrian only - Signal          | Pedestrian Mid-block Crossing | 2_6                        | -   | -             |
| 53   | CEN05           | Central Station        | Elizabeth St / Randle St   | Signal                            | 3-leg Intersection            | 1_5_6                      | CEN-N2  | -             |
| 54   | WLO01           | Waterloo Station       | Botany Rd / Raglan St / Henderson Rd   | Signal                            | 4-leg Intersection            | 1_3_5_7                    | WLO-N1  | Offset_WLO-N1 |
| 55   | WLO02           | Waterloo Station       | Raglan St / Cope St  | Roundabout                        | 4-leg Intersection            | 1_3_5_7                    | WLO-N1  | -             |
| 56   | WLO03           | Waterloo Station       | Botany Rd / Wellington St / Buckland St                                      | Signal                            | 4-leg Intersection            | 1_3_5_7                    | WLO-N1  | Offset_WLO-N1 |
| 57   | WLO04           | Waterloo Station       | Cope St / Wellington St  | Roundabout                        | 4-leg Intersection            | 1_3_5_7                    | WLO-N1  | -             |
| 58   | WLO05           | Waterloo Station       | Wyndham St / Henderson Rd  | Signal                            | 4-leg Intersection            | 1_3_5_7                    | WLO-N1  | Offset_WLO-N1 |
| 59   | WLO06           | Waterloo Station       | New Pedestrian Mid-block Crossing at Cope St                                 | Pedestrian only - Signal          | Pedestrian Mid-block Crossing | 1_5                        | -   | -             |
| 60   | SYD01           | Sydenham Station       | Railway Pde / Gleeson Ave  | Signal                            | 3-leg Intersection            | 2_4_6                      | SYD-N1  | -             |
| 61   | SYD02           | Sydenham Station       | Burrows Ave / Gleeson Ave  | Signal                            | 4-leg Intersection            | 2_4_6_8                    | SYD-N1  | -             |
| 62   | SYD03           | Sydenham Station       | Burrows Ave / George St  | Priority - Give Way               | 3-leg Intersection            | 2_4_6                      | -   | -             |
| 63   | SYD04           | Sydenham Station       | Pedestrian Mid-block Crossing at Sydenham Rd                                 | Pedestrian only - Signal          | Pedestrian Mid-block Crossing | 5_8                        | -   | -             |
| 64   | SYD05           | Sydenham Station       | Marrickville Rd / Buckley St   | Priority - Give Way               | 3-leg Intersection            | 2_4_8                      | -   | -             |
| 65   | SYD06           | Sydenham Station       | Sydenham Rd / Buckley St   | Priority - Give Way               | 3-leg Intersection            | 4_6_8                      | -   | -             |

## Sydney Metro City & Southwest - Traffic and Interchange Operation Monitoring

Intersection Geometry

Source: Nearmap accessed XX XX XXXX

Include NearMaps layout (already prepared for each site) and include a markup showing the approach distances, short lane lengths, parking zone, no stopping zone etc.

Include SIDRA model layout



Sydney Metro City & Southwest - Traffic and Interchange Operation Monitoring

SIDRA Model Review Checklist

Site Name:  
 Site ID:  
 Type:  
 Scenario:

|             |  |
|-------------|--|
| Status      |  |
| Open        | Attention Required for modeller / reviewer |
| In Progress | Working in progress                        |
| Closed      | Closed                                     |
| N/A         | Not Applicable/Not Required                |

Links to:  
 SIDRA File  
 Traffic Volume Input  
 SCATS Data TCS Plan

Modeller:  
 Reviewer:  
 Verifier:

| Item | Model Element                    | Notes (For modeller)   | Modeller |       | AM Peak Reviewer |       | Verifier |       | Modeller |       | PM Peak Reviewer |       | Verifier |       | Modeller |       | Weekend Peak Reviewer |       |
|------|----------------------------------|--|----------|-------|------------------|-------|----------|-------|----------|-------|------------------|-------|----------|-------|----------|-------|-----------------------|-------|
|      |                                  |  | Status   | Notes | Status           | Notes | Status   | Notes | Status   | Notes | Status           | Notes | Status   | Notes | Status   | Notes | Status                | Notes |
| 1    | General                          |  | Open     |       | Open             |       | Open     |       | Open     |       | Open             |       | Open     |       | Open     |       | Open                  |       |
| 1.1  | SIDRA Setup                      | New South Wales  | Open     |       | Open             |       | Open     |       | Open     |       | Open             |       | Open     |       | Open     |       | Open                  |       |
| 1.2  | Intersection Type                | For priority intersections, check for 'give way' or 'stop'   | Open     |       | Open             |       | Open     |       | Open     |       | Open             |       | Open     |       | Open     |       | Open                  |       |
| 2    | Intersection                     |  | Open     |       | Open             |       | Open     |       | Open     |       | Open             |       | Open     |       | Open     |       | Open                  |       |
| 2.1  | Site Name                        | To be consistent with the Intersection Master List   | Open     |       | Open             |       | Open     |       | Open     |       | Open             |       | Open     |       | Open     |       | Open                  |       |
| 2.2  | Site Title                       | Include TCS numbers in the model, if applicable  | Open     |       | Open             |       | Open     |       | Open     |       | Open             |       | Open     |       | Open     |       | Open                  |       |
| 2.3  | Approach Names                   | Include as per Nearmap, compare with Intersection Master List  | Open     |       | Open             |       | Open     |       | Open     |       | Open             |       | Open     |       | Open     |       | Open                  |       |
| 2.4  | Lane Geometry                    | Two-way, one-way etc.  | Open     |       | Open             |       | Open     |       | Open     |       | Open             |       | Open     |       | Open     |       | Open                  |       |
| 2.5  | Approach/Exit Distance           | Check and update as per NearMaps (distance till the next intersection if more than 500m)   | Open     |       | Open             |       | Open     |       | Open     |       | Open             |       | Open     |       | Open     |       | Open                  |       |
| 2.6  | Extra Bunching                   | For isolated intersections, include as per Traffic modelling guidelines. For sites in the network, ensure Program option is selected for 'network internal' approaches (user input should still be included for 'network external' approaches, where applicable) | Open     |       | Open             |       | Open     |       | Open     |       | Open             |       | Open     |       | Open     |       | Open                  |       |
| 3    | Movement Definitions             |  | Open     |       | Open             |       | Open     |       | Open     |       | Open             |       | Open     |       | Open     |       | Open                  |       |
| 3.1  | Vehicle Types                    | Confirm inclusion of Buses, Bicycles, if relevant (for easier volume input, select Bus and bicycles for all intersections)   | Open     |       | Open             |       | Open     |       | Open     |       | Open             |       | Open     |       | Open     |       | Open                  |       |
| 3.2  | OD Movements                     | Switch off banned movements as per site observations, compare with Intersection Master list for banned movements.  | Open     |       | Open             |       | Open     |       | Open     |       | Open             |       | Open     |       | Open     |       | Open                  |       |
| 4    | Lane Geometry                    |  | Open     |       | Open             |       | Open     |       | Open     |       | Open             |       | Open     |       | Open     |       | Open                  |       |
| 4.1  | Lane Configuration / Length      | Check the full length of lane and 'short lane' based on Nearmap - refer Intersection Geometry tab (round to 5m)  | Open     |       | Open             |       | Open     |       | Open     |       | Open             |       | Open     |       | Open     |       | Open                  |       |
| 4.2  | Lane Type                        | High angle or Low angle for slip lanes   | Open     |       | Open             |       | Open     |       | Open     |       | Open             |       | Open     |       | Open     |       | Open                  |       |
| 4.3  | Lane Control                     |  | Open     |       | Open             |       | Open     |       | Open     |       | Open             |       | Open     |       | Open     |       | Open                  |       |
| 4.4  | Overflow Lane Number             |  | Open     |       | Open             |       | Open     |       | Open     |       | Open             |       | Open     |       | Open     |       | Open                  |       |
| 4.5  | Grade                            | A default 0% grade will be applied to all lanes. / TCS plans where applicable.   | Open     |       | Open             |       | Open     |       | Open     |       | Open             |       | Open     |       | Open     |       | Open                  |       |
| 4.6  | Lane Disciplines                 | Update if specific movement classes have banned movements (for eq. Right turn only for buses)  | Open     |       | Open             |       | Open     |       | Open     |       | Open             |       | Open     |       | Open     |       | Open                  |       |
| 4.7  | Lane Capacity Adjustment         | Justifications based on site observations required if these factors are adjusted   | Open     |       | Open             |       | Open     |       | Open     |       | Open             |       | Open     |       | Open     |       | Open                  |       |
| 5    | Lane Movements                   |  | Open     |       | Open             |       | Open     |       | Open     |       | Open             |       | Open     |       | Open     |       | Open                  |       |
| 5.1  | Lane Movement Proportion         | As per site observations or survey videos. From approach lane to exit lane (e.g. bus lane on approach side should direct to bus lane on exit side)   | Open     |       | Open             |       | Open     |       | Open     |       | Open             |       | Open     |       | Open     |       | Open                  |       |
| 6    | Roundabout (if applicable)       |  | Open     |       | Open             |       | Open     |       | Open     |       | Open             |       | Open     |       | Open     |       | Open                  |       |
| 6.1  | Number of Lanes                  |  | N/A      |       | N/A              |       | N/A      |       | N/A      |       | N/A              |       | N/A      |       | N/A      |       | N/A                   |       |
| 6.2  | Circulating Width                |  | N/A      |       | N/A              |       | N/A      |       | N/A      |       | N/A              |       | N/A      |       | N/A      |       | N/A                   |       |
| 6.3  | Island Diameter                  |  | N/A      |       | N/A              |       | N/A      |       | N/A      |       | N/A              |       | N/A      |       | N/A      |       | N/A                   |       |
| 6.4  | Ped Crossing at Roundabout       | Include ped crossing for all roundabouts (with / without zebra crossing); if there's no zebra crossing, make a note in the checklist - 'No zebra crossing, priority settings (ped or veh) to be further revised with survey footage to calibrate the model'      | N/A      |       | N/A              |       | N/A      |       | N/A      |       | N/A              |       | N/A      |       | N/A      |       | N/A                   |       |
| 7    | Pedestrians                      |  | Open     |       | Open             |       | Open     |       | Open     |       | Open             |       | Open     |       | Open     |       | Open                  |       |
| 7.1  | Crossing Location / Type         | Full crossing / staged crossing / slip lane crossing (signalised or zebra)   | Open     |       | Open             |       | Open     |       | Open     |       | Open             |       | Open     |       | Open     |       | Open                  |       |
| 7.2  | Pedestrian Volume                | Update as per surveys  | Open     |       | Open             |       | Open     |       | Open     |       | Open             |       | Open     |       | Open     |       | Open                  |       |
| 7.3  | Peak Flow Factor                 | 95%  | Open     |       | Open             |       | Open     |       | Open     |       | Open             |       | Open     |       | Open     |       | Open                  |       |
| 7.4  | Crossing Distance                | Based on intersection geometry (round to 0.5m)   | Open     |       | Open             |       | Open     |       | Open     |       | Open             |       | Open     |       | Open     |       | Open                  |       |
| 7.5  | Walking Speed (Average)          | 1.2 m/s (as recommended in RMS Modelling Guide)  | Open     |       | Open             |       | Open     |       | Open     |       | Open             |       | Open     |       | Open     |       | Open                  |       |
| 7.6  | Pedestrian Timing Data           | Adopt the SCATS walk time as minimum walk time, minimum clearance as default 5 sec, Clearance 1 & 2 as per SCATS data  | Open     |       | Open             |       | Open     |       | Open     |       | Open             |       | Open     |       | Open     |       | Open                  |       |
| 7.7  | Walk Time Extension              | Remain as 'unticked' (can adjust based on survey videos, where applicable)   | Open     |       | Open             |       | Open     |       | Open     |       | Open             |       | Open     |       | Open     |       | Open                  |       |
| 8    | Volumes                          |  | Open     |       | Open             |       | Open     |       | Open     |       | Open             |       | Open     |       | Open     |       | Open                  |       |
| 8.1  | Vehicle Volumes                  | Check individual intersections; For network model, check midblock flows (ensure input volumes are set to 'Separate')   | Open     |       | Open             |       | Open     |       | Open     |       | Open             |       | Open     |       | Open     |       | Open                  |       |
| 8.2  | Peak Flow Period                 | 30 minutes   | Open     |       | Open             |       | Open     |       | Open     |       | Open             |       | Open     |       | Open     |       | Open                  |       |
| 8.3  | Peak Flow Factor                 | 95%  | Open     |       | Open             |       | Open     |       | Open     |       | Open             |       | Open     |       | Open     |       | Open                  |       |
| 9    | Priorities                       |  | Open     |       | Open             |       | Open     |       | Open     |       | Open             |       | Open     |       | Open     |       | Open                  |       |
| 9.1  | Priorities                       | Ensure priority settings updated for turn movements at signals with opposed ped movements  | Open     |       | Open             |       | Open     |       | Open     |       | Open             |       | Open     |       | Open     |       | Open                  |       |
| 10   | Gap Acceptance                   |  | Open     |       | Open             |       | Open     |       | Open     |       | Open             |       | Open     |       | Open     |       | Open                  |       |
| 10.1 | Opposing Peds (Extra Loss)       | Justifications required if these factors are adjusted  | Open     |       | Open             |       | Open     |       | Open     |       | Open             |       | Open     |       | Open     |       | Open                  |       |
| 11   | Vehicle Movement Data            |  | Open     |       | Open             |       | Open     |       | Open     |       | Open             |       | Open     |       | Open     |       | Open                  |       |
| 11.1 | Approach / Exit Cruise Speed     | Based on posted speed limits or agreed assumptions (if no posted speed limits)   | Open     |       | Open             |       | Open     |       | Open     |       | Open             |       | Open     |       | Open     |       | Open                  |       |
| 11.2 | Start Loss / End Gain            | Justifications required if these factors are adjusted  | Open     |       | Open             |       | Open     |       | Open     |       | Open             |       | Open     |       | Open     |       | Open                  |       |
| 11.3 | Early Cut-Off / Late Start       | Justifications required if these factors are adjusted  | Open     |       | Open             |       | Open     |       | Open     |       | Open             |       | Open     |       | Open     |       | Open                  |       |
| 12   | Phasing & Timing (if applicable) |  | Open     |       | Open             |       | Open     |       | Open     |       | Open             |       | Open     |       | Open     |       | Open                  |       |
| 12.1 | Phasing Arrangements             | As per SCATS, TCS Plan   | Open     |       | Open             |       | Open     |       | Open     |       | Open             |       | Open     |       | Open     |       | Open                  |       |
| 12.2 | Red Arrow Drop Off               |  | Open     |       | Open             |       | Open     |       | Open     |       | Open             |       | Open     |       | Open     |       | Open                  |       |
| 12.3 | Phase Time / Frequency           | User-give phase times. Frequency as per SCATS/Site observations  | Open     |       | Open             |       | Open     |       | Open     |       | Open             |       | Open     |       | Open     |       | Open                  |       |
| 12.4 | Yellow Time                      | As per SCATS (if SCATS data indicates 5. round up and leave a note in the checklist)   | Open     |       | Open             |       | Open     |       | Open     |       | Open             |       | Open     |       | Open     |       | Open                  |       |
| 12.5 | All-Red Time                     | As per SCATS (if SCATS data indicates 5. round up and leave a note in the checklist)   | Open     |       | Open             |       | Open     |       | Open     |       | Open             |       | Open     |       | Open     |       | Open                  |       |
| 13   | Performance Settings             |  | Open     |       | Open             |       | Open     |       | Open     |       | Open             |       | Open     |       | Open     |       | Open                  |       |
| 13.1 | Site LoS Method                  | Delay (RTA NSW); Site Level of Service Target LoS C  | Open     |       | Open             |       | Open     |       | Open     |       | Open             |       | Open     |       | Open     |       | Open                  |       |
| 13.2 | Queue in Output                  |  | Open     |       | Open             |       | Open     |       | Open     |       | Open             |       | Open     |       | Open     |       | Open                  |       |
| 13.3 | PCU factor                       | LV: 1.0, HV & Bus: 2.0, Bicycles: 0.3  | Open     |       | Open             |       | Open     |       | Open     |       | Open             |       | Open     |       | Open     |       | Open                  |       |

**Sydney Metro City & Southwest - Traffic and Interchange Operation Monitoring**  
 SIDRA Network Model Coverage

|            |               |
|------------|---------------|
| Site Name: | CHW Network 1 |
| Site ID:   | Network       |
| Type:      | N/A           |
| Scenario:  | TBC           |

| Status      |  |
|-------------|--|
| Open        | Attention Required for modeller / reviewer |
| In Progress | Working in progress                        |
| Closed      | Closed                                     |
| N/A         | Not Applicable/Not Required                |

| Links to:            |  |
|----------------------|--|
| SIDRA File           |  |
| Traffic Volume Input |  |
| SCATS Data           |  |

|           |  |
|-----------|--|
| Modeller: |  |
| Reviewer: |  |
| Verifier: |  |

| Item | Model Element                | Notes                                     | AM Peak  |          |          | PM Peak  |          |          | Sat Peak |          |          |
|------|------------------------------|---|----------|----------|----------|----------|----------|----------|----------|----------|----------|
|      |                              |   | Modeller | Reviewer | Verifier | Modeller | Reviewer | Verifier | Modeller | Reviewer | Verifier |
| 1    | Network Data                 |   | Open     | Open     | Open     | Open     | Open     | Open     | Open     | Open     | Open     |
| 1.1  | Queue in Output              | 95th Percentile                           | Open     | Open     | Open     | Open     | Open     | Open     | Open     | Open     | Open     |
| 1.2  | Maximum Number of Iterations | 30; unless notes are given in Diagnostics | Open     | Open     | Open     | Open     | Open     | Open     | Open     | Open     | Open     |
| 2    | CCGs                         |   | Open     | Open     | Open     | Open     | Open     | Open     | Open     | Open     | Open     |
| 2.1  | CCG Set Up                   | If applicable                             | Open     | Open     | Open     | Open     | Open     | Open     | Open     | Open     | Open     |
| 3    | Network Timing               |   | Open     | Open     | Open     | Open     | Open     | Open     | Open     | Open     | Open     |
| 3.1  | Coordinated Site Selection   | If applicable                             | Open     | Open     | Open     | Open     | Open     | Open     | Open     | Open     | Open     |
| 3.2  | User Offset                  | If applicable                             | Open     | Open     | Open     | Open     | Open     | Open     | Open     | Open     | Open     |
| 3.3  | Route Definition             | If applicable                             | Open     | Open     | Open     | Open     | Open     | Open     | Open     | Open     | Open     |
| 3.4  | Network Cycle Time           | If applicable                             | Open     | Open     | Open     | Open     | Open     | Open     | Open     | Open     | Open     |

# Appendix C

## Network Flow Diagrams

# Appendix C Network Flow Diagrams

**Block 1**

Dropdowns:

Vehicle Type:

ALL VEHICLES

Time Period:

AM

CWD01 - 8:15 AM (Wed)

CWD02 - 8:15 AM (Wed)

**Legend:**

- Approach Number
- Approach Total
- Departure Total

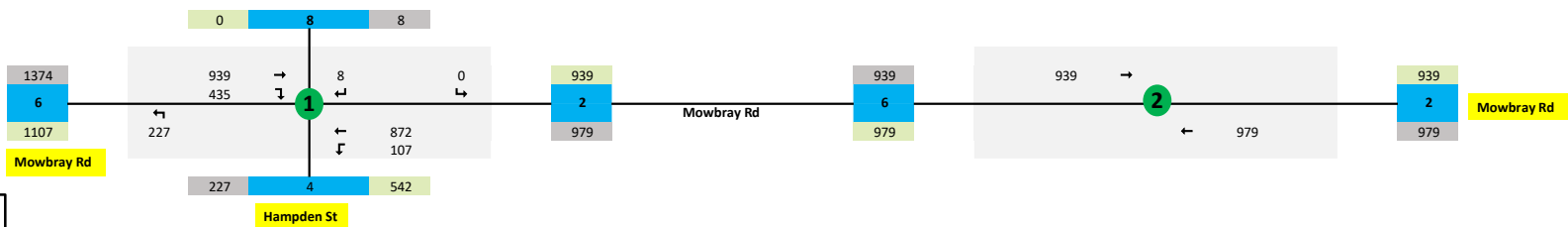



Block 1

Dropdowns:

Vehicle Type:

ALL VEHICLES

Time Period:

AM

CST-N1 - 8:15 AM (Wed)

CST07 - 8:30 AM (Mon)

CST08 - 8:15 AM (Mon)

Legend:

Approach Number

Approach Total

Departure Total

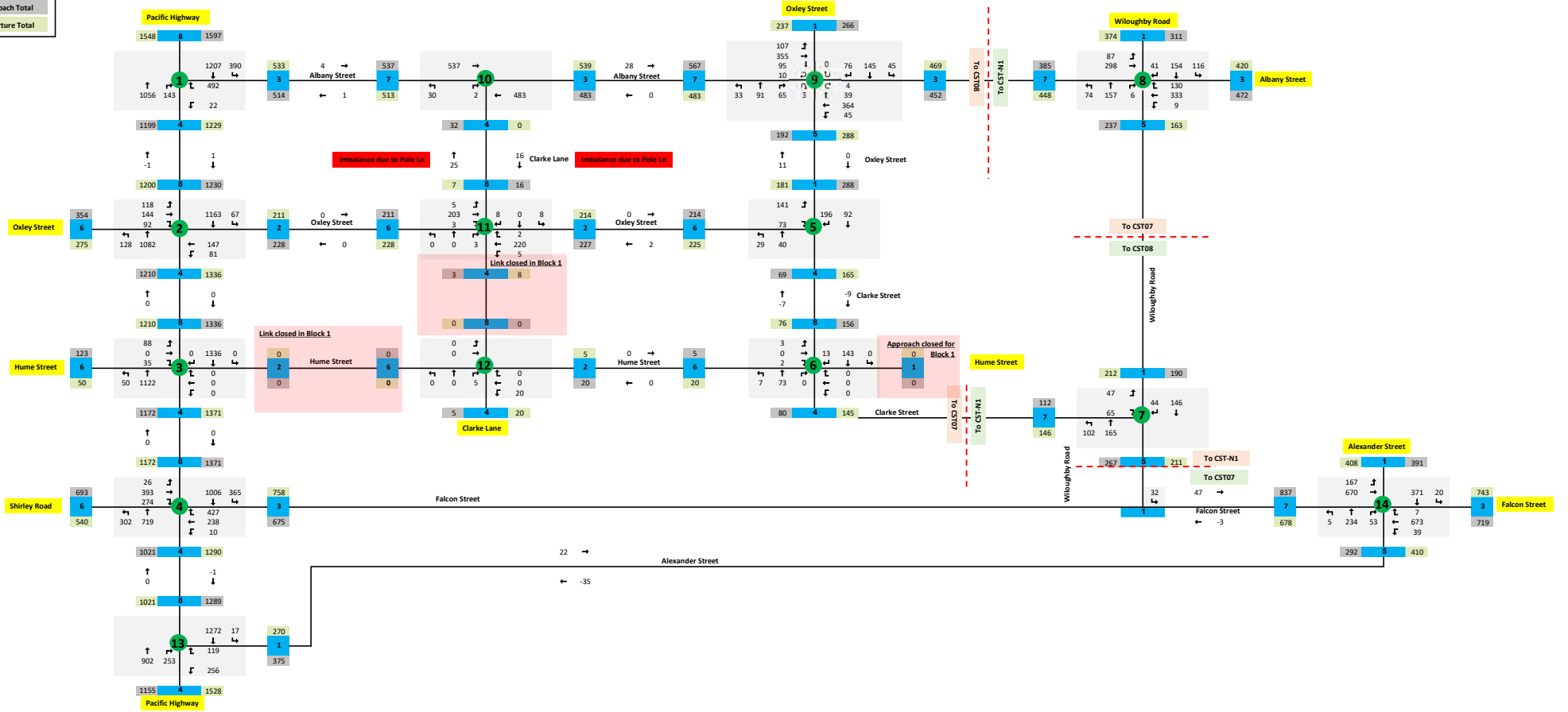

**Block 1**

Dropdowns:

Vehicle Type:

ALL VEHICLES

Time Period:

AM

VIC-N1 - 8:45 AM (Mon)

**Legend:**

Approach Number

Approach Total

Departure Total

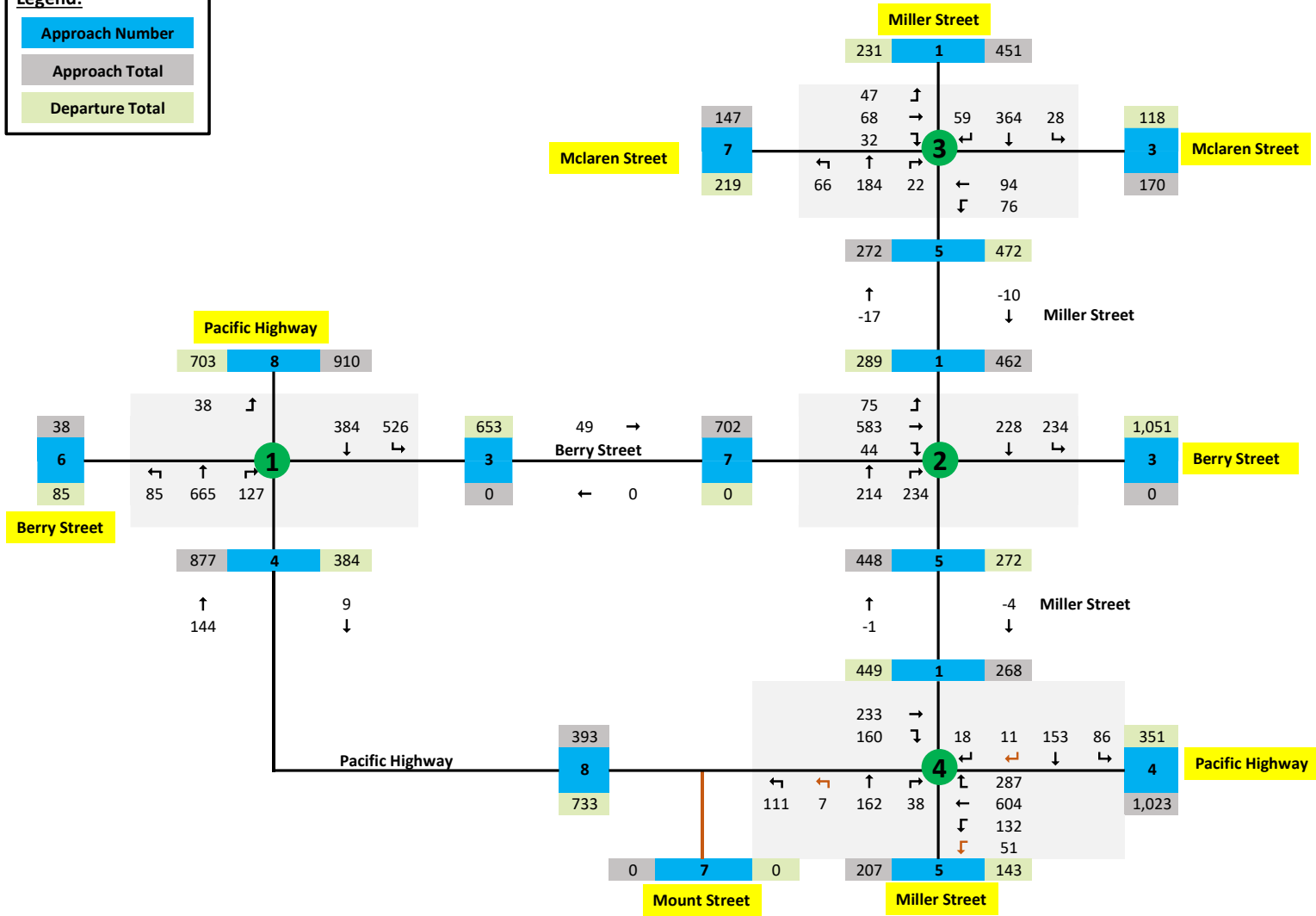

Block 1

- Dropped:  
 Vehicle Type:  
 ALL VEHICLES  
 Time Period:  
 AM  
 BGU-N1 - 8:45 AM (Tue)  
 BGU-N2 - 8:30 AM (Tue)  
 BGU-N3 - 8:30 AM (Tue)  
 BGU-N4 - 8:30 AM (Tue)

Legend:

|                 |
|-----------------|
| Approach Number |
| Approach Total  |
| Departure Total |

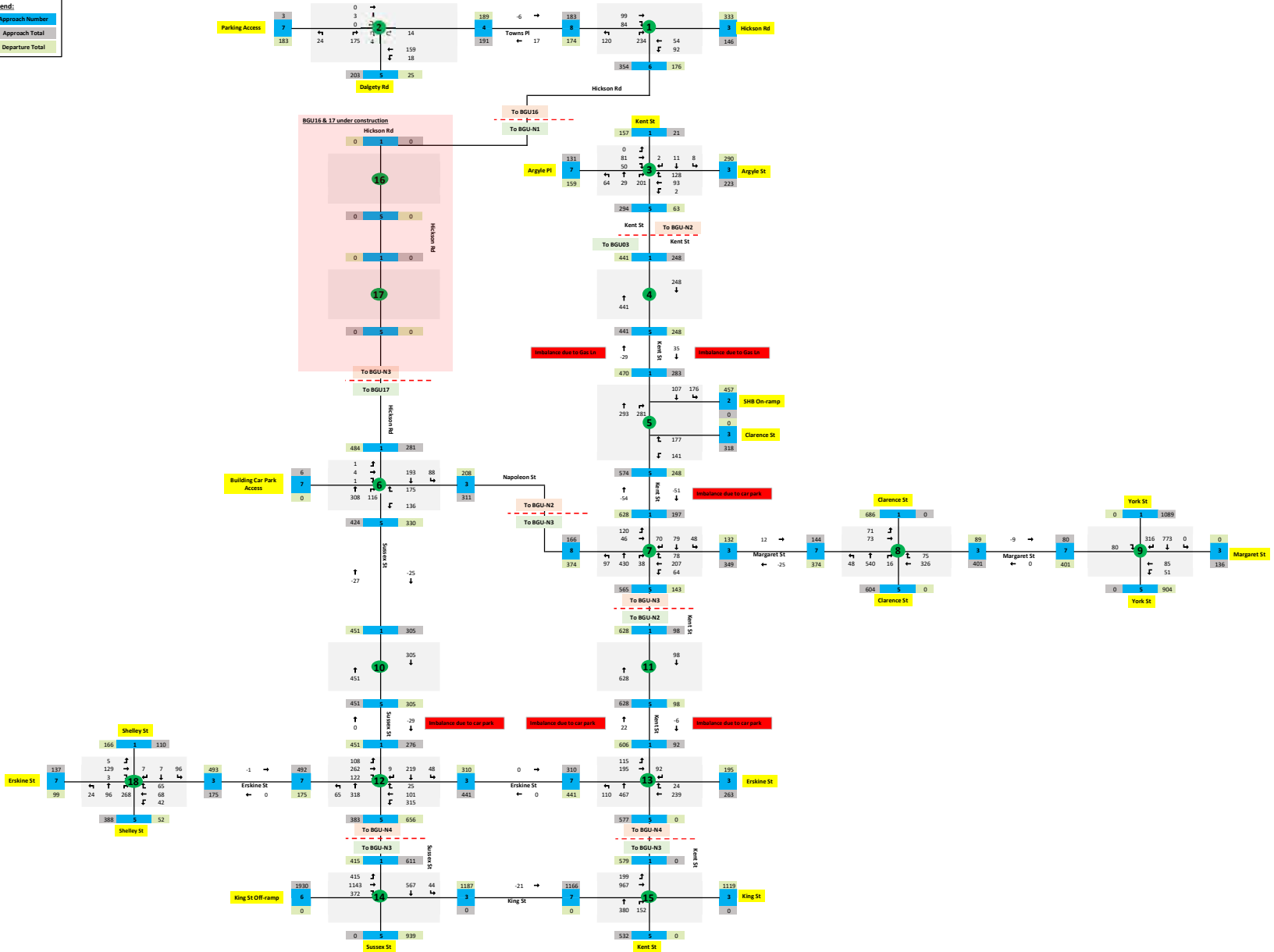

Block 1

Dropdown:

Vehicle Type:

Cyclists

Scenario:

BALANCED

Time Period:

07:00 - 08:00

BGU-N1 - 8:45 AM (Tue)

BGU-N2 - 8:30 AM (Tue)

BGU-N3 - 8:30 AM (Tue)

BGU-N4 - 8:30 AM (Tue)

Legend:

Approach Number

Approach Total

Departure Total

Approach

Approach

Approach

Approach

Approach

Approach

Approach

Approach

Approach

Approach

Approach

Approach

Approach

Approach

Approach

Approach

Approach

Approach

Approach

Approach

Approach

Approach

Approach

Approach

Approach

Approach

Approach

Approach

Approach

Approach

Approach

Approach

Approach

Approach

Approach

Approach

Approach

Approach

Approach

Approach

Approach

Approach

Approach

Approach

Approach

Approach

Approach

Approach

Approach

Approach

Approach

Approach

Approach

Approach

Approach

Approach

Approach

Approach

Approach

Approach

Approach

Approach

Approach

Approach

Approach

Approach

Approach

Approach

Approach

Approach

Approach

Approach

Approach

Approach

Approach

Approach

Approach

Approach

Approach

Approach

Approach

Approach

Approach

Approach

Approach

Approach

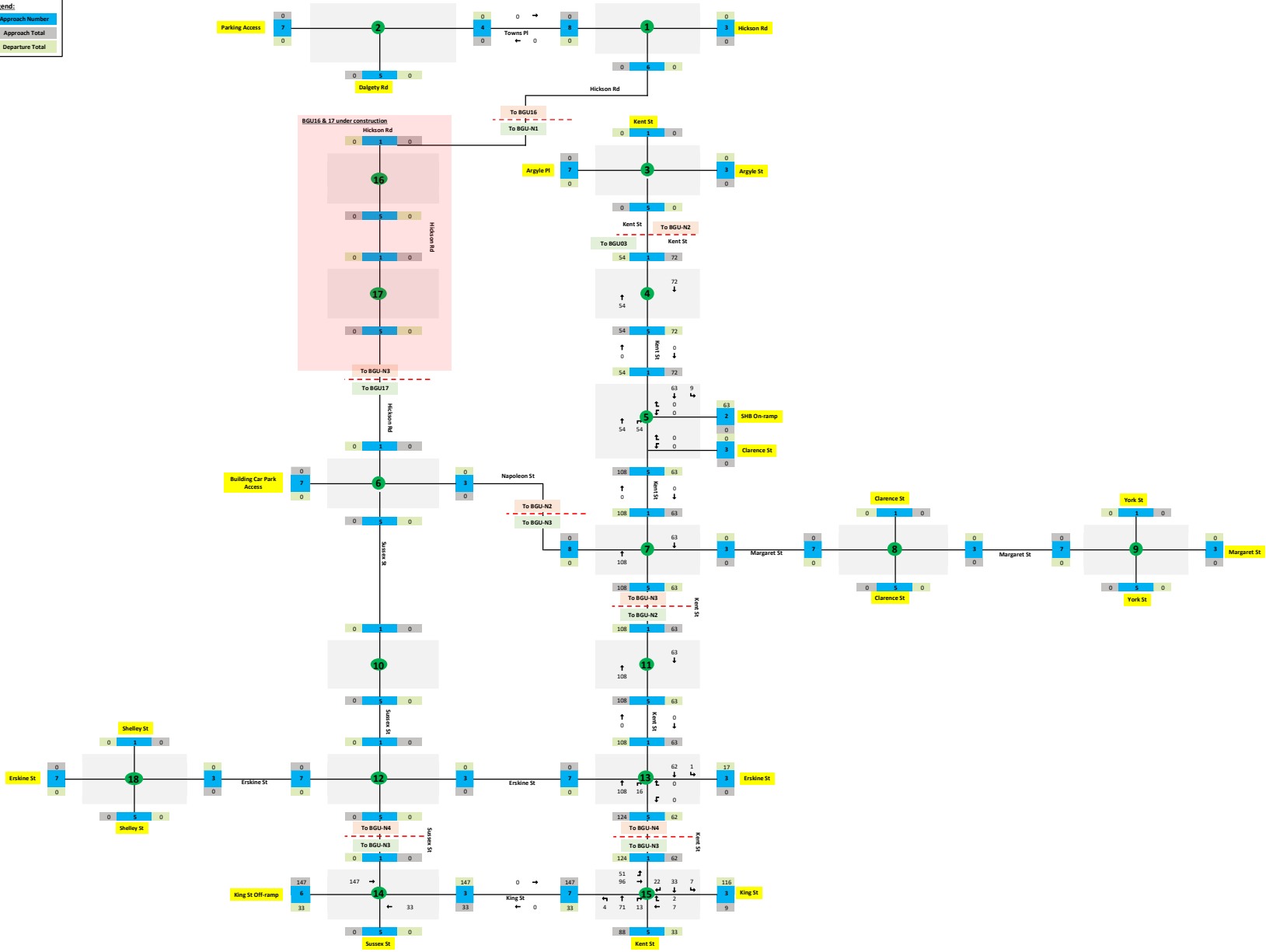

**Block 1**

Dropdowns:

Vehicle Type:

ALL VEHICLES

Time Period:

AM

MPL-N1 - 9:00 AM (Wed)

MPL05 - 9:00 AM (Tue)

MPL06 - 8:45 AM (Wed)

**Legend:**

- Approach Number
- Approach Total
- Departure Total

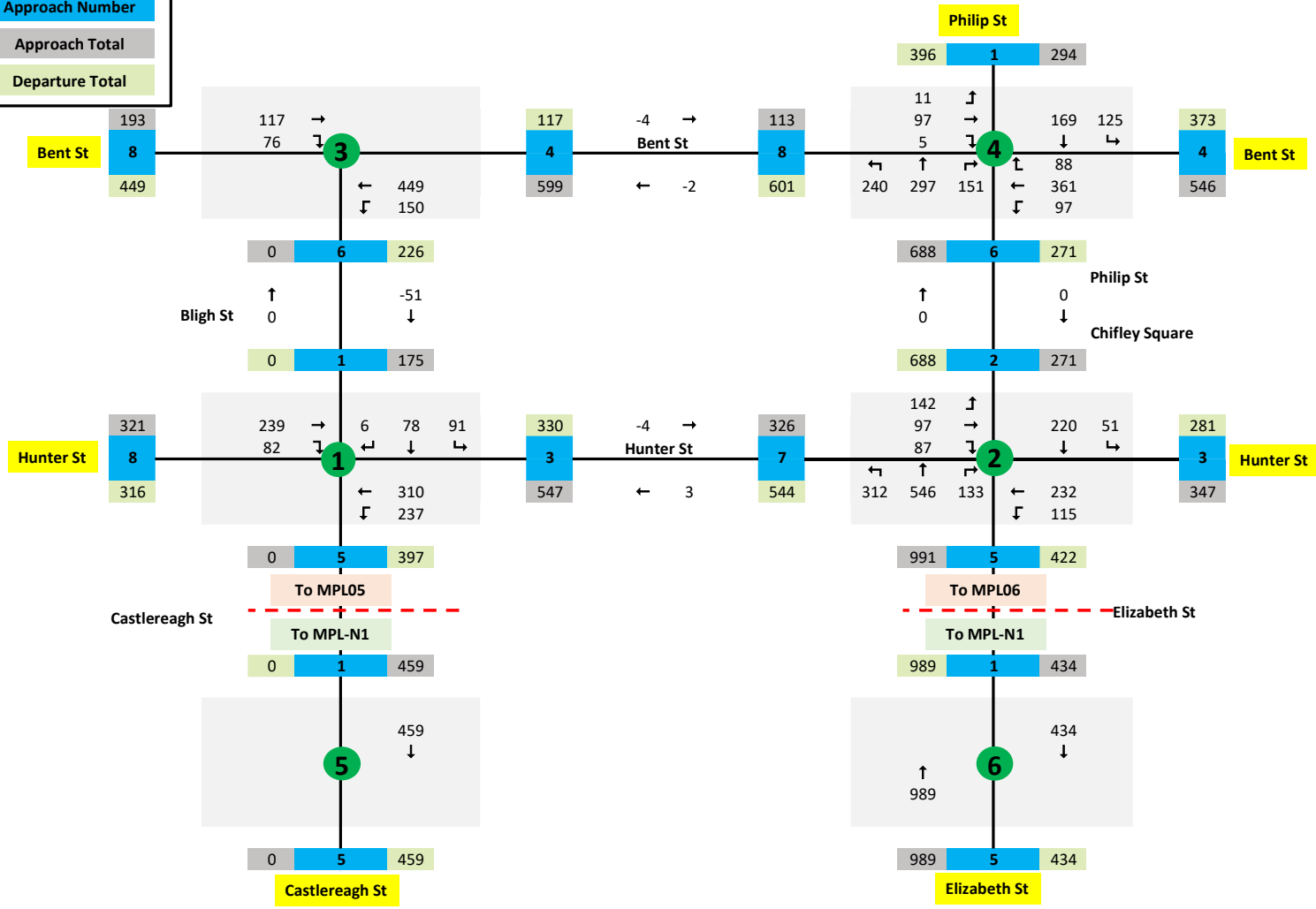



**Block 1**

Dropdowns:

Vehicle Type:

ALL VEHICLES

Time Period:

AM

PIT-N1 - 9:15 AM (Tue)

**Legend:**

- Approach Number
- Approach Total
- Departure Total

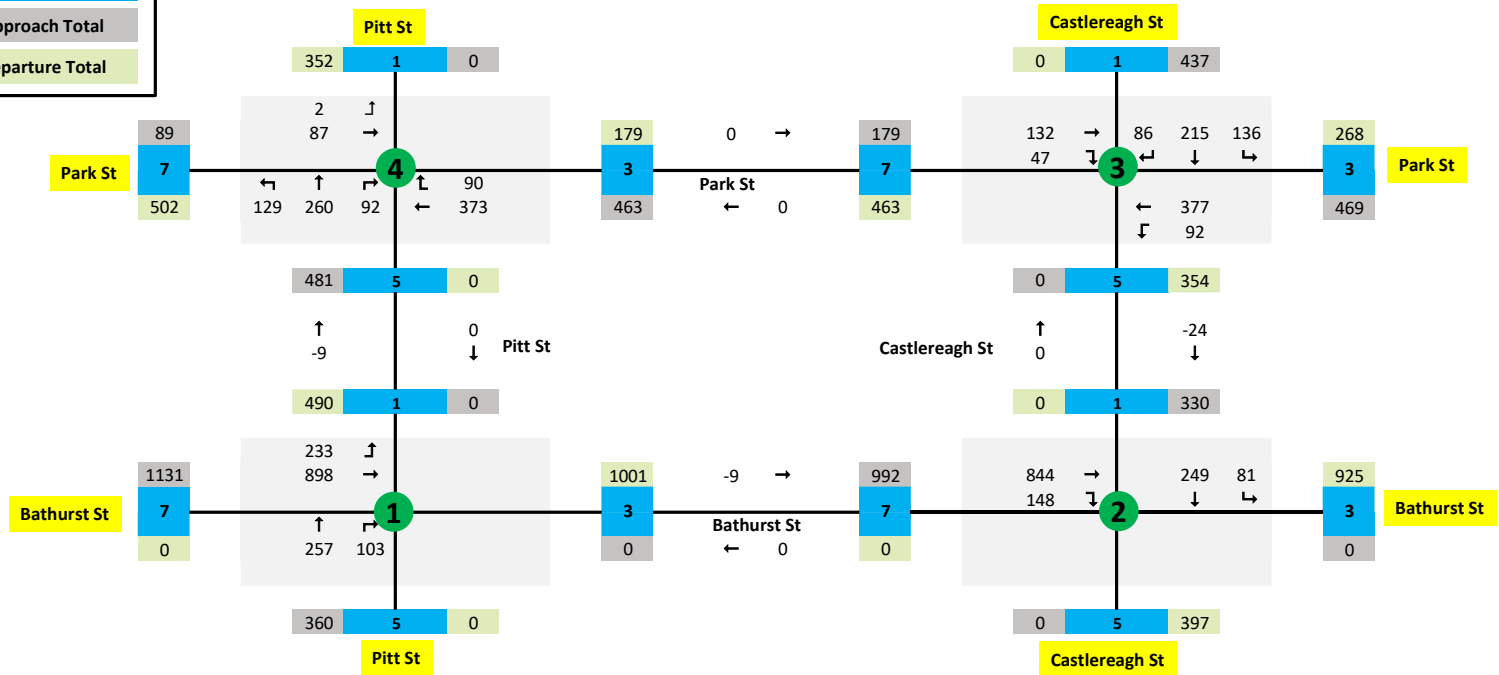

**Block 1**

Dropdowns:

Vehicle Type:

ALL VEHICLES

Time Period:

AM

CEN-N1 - 8:15 AM (Wed)

CEN-N2 - 8:15 AM (Thu)

**Legend:**

Approach Number

Approach Total

Departure Total

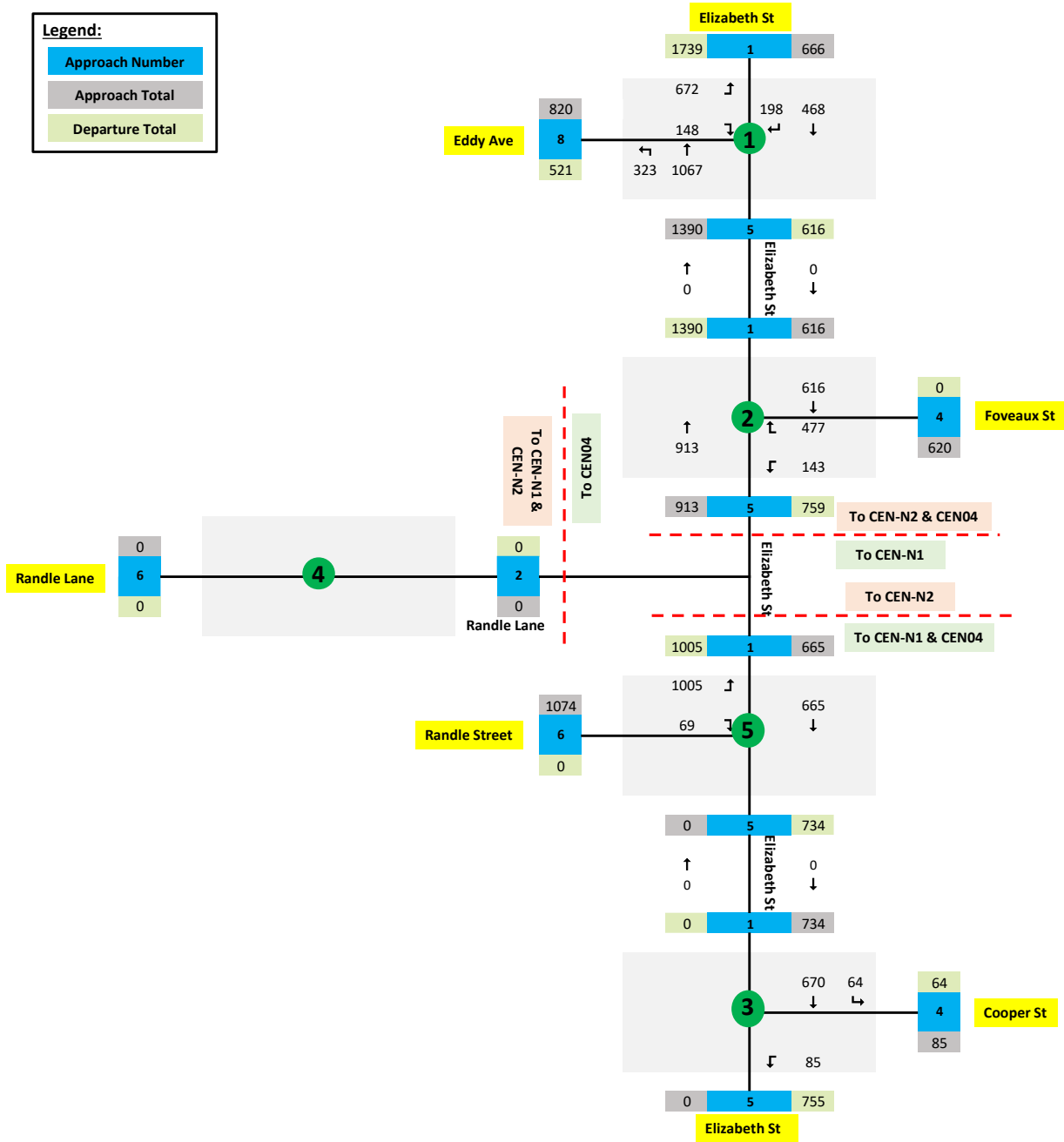

**Block 1**

Dropdowns:  
 Vehicle Type:  
 ALL VEHICLES  
 Time Period:  
 AM  
 WLO-N1 - 8:15 AM (Wed)

**Legend:**

- Approach Number
- Approach Total
- Departure Total

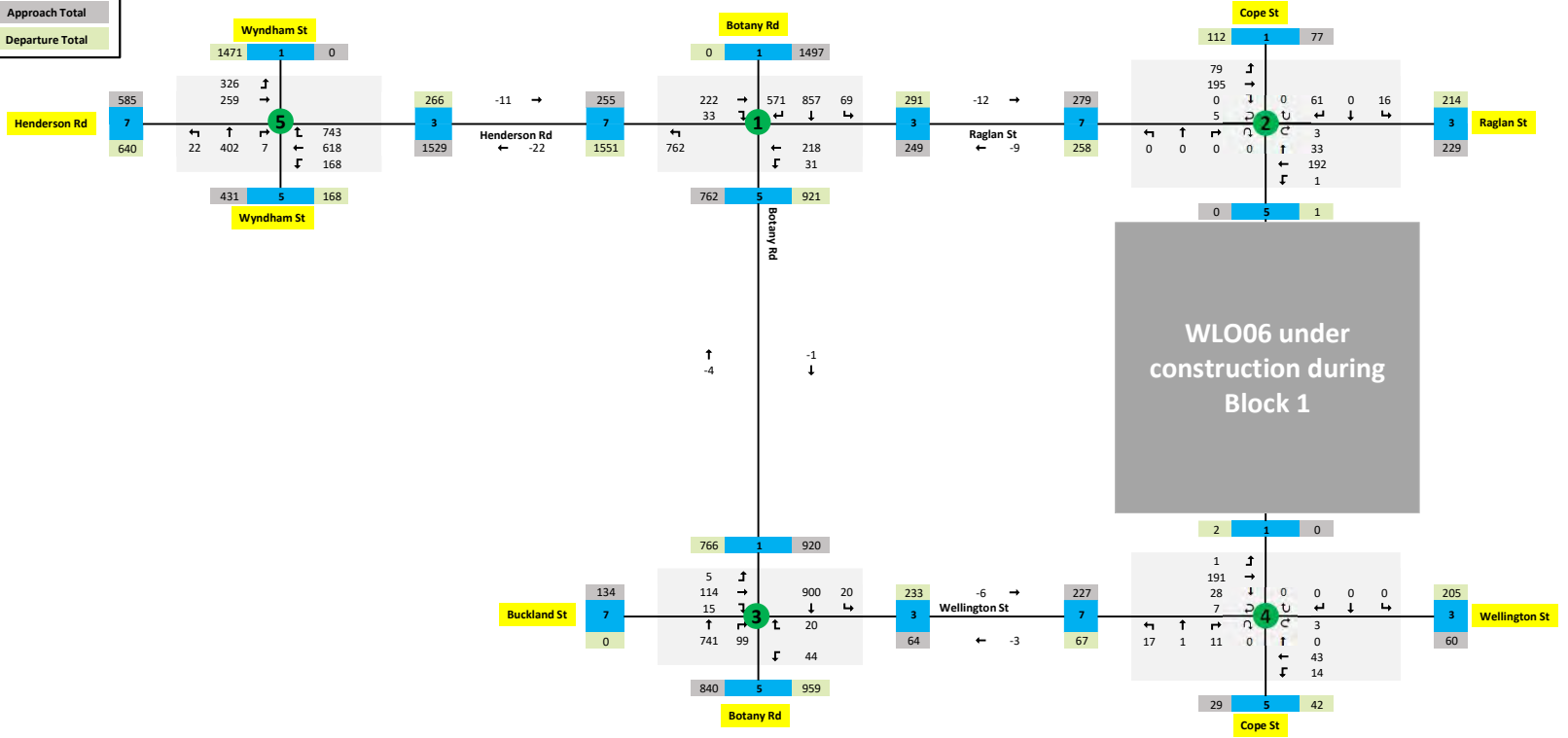

Block 1

Dropdowns:

Vehicle Type:

ALL VEHICLES

Time Period:

AM

SYD-N1 - 7:45 AM (Wed)

SYD03 - 7:30 AM (Tue)

SYD04 - 8:15 AM (Tue)

SYD05 - 8:15 AM (Tue)

SYD06 - 8:15 AM (Tue)

Legend:

Approach Number

Approach Total

Departure Total

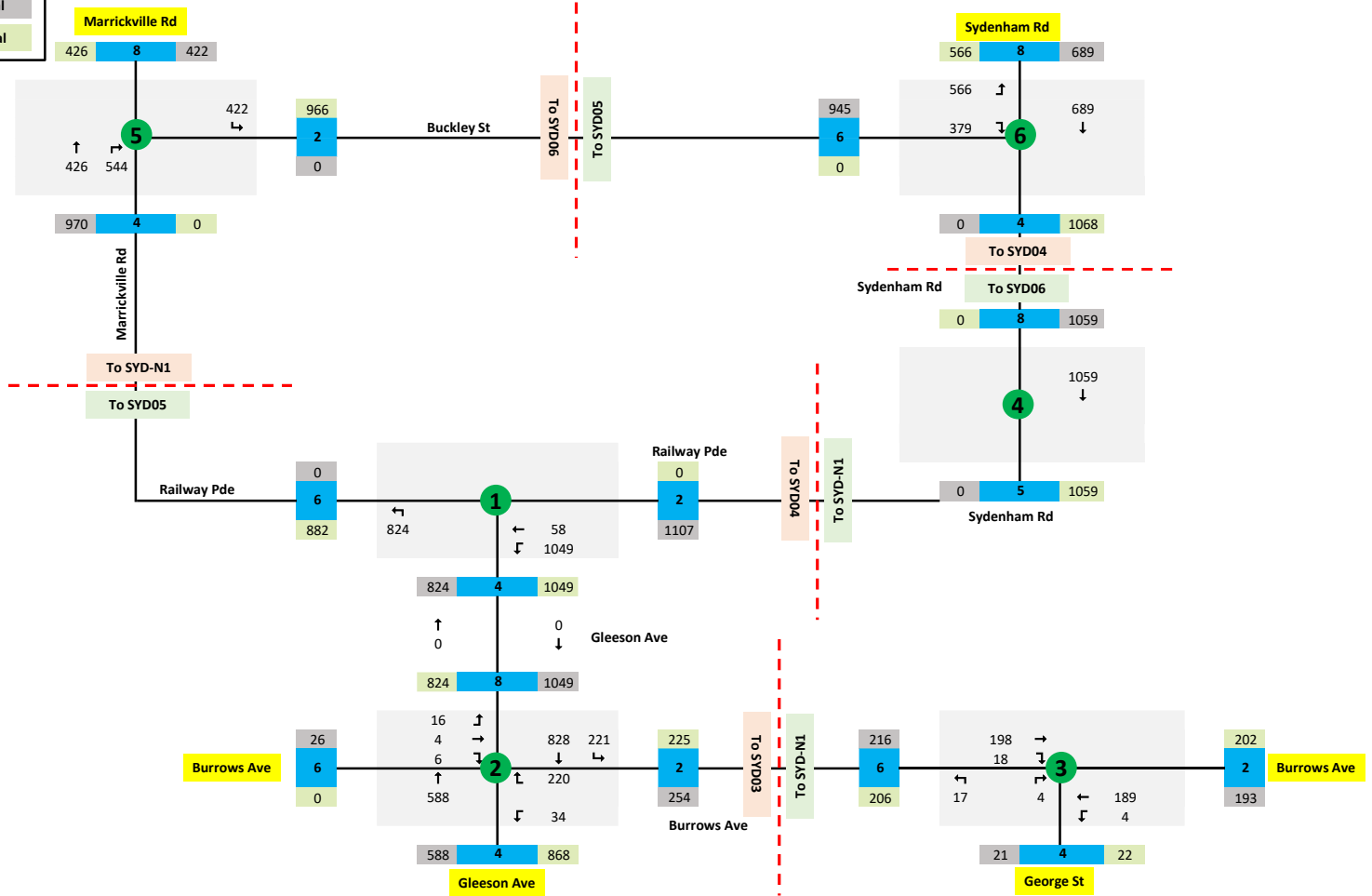

**Block 1**

Dropdowns:

Vehicle Type:

ALL VEHICLES

Time Period:

PM

CWD01 - 3:15 PM (Fri)

CWD02 - 3:15 PM (Fri)

**Legend:**

- Approach Number
- Approach Total
- Departure Total

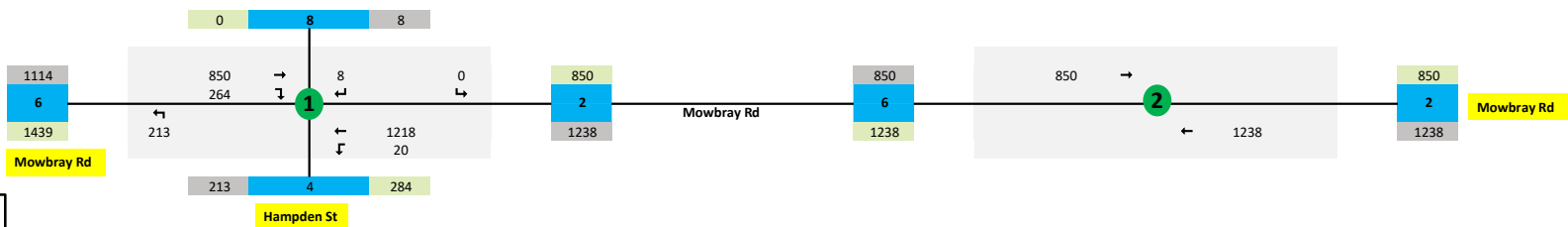



Block 1

Dropdowns:

Vehicle Type: ALLVEHICLES

Time Period: PM

CST-N1 - 4:45 PM (Tue)

CST07 - 5:45 PM (Fri)

CST08 - 5:00 PM (Thu)

**Legend:**

- Approach Number
- Approach Total
- Departure Total

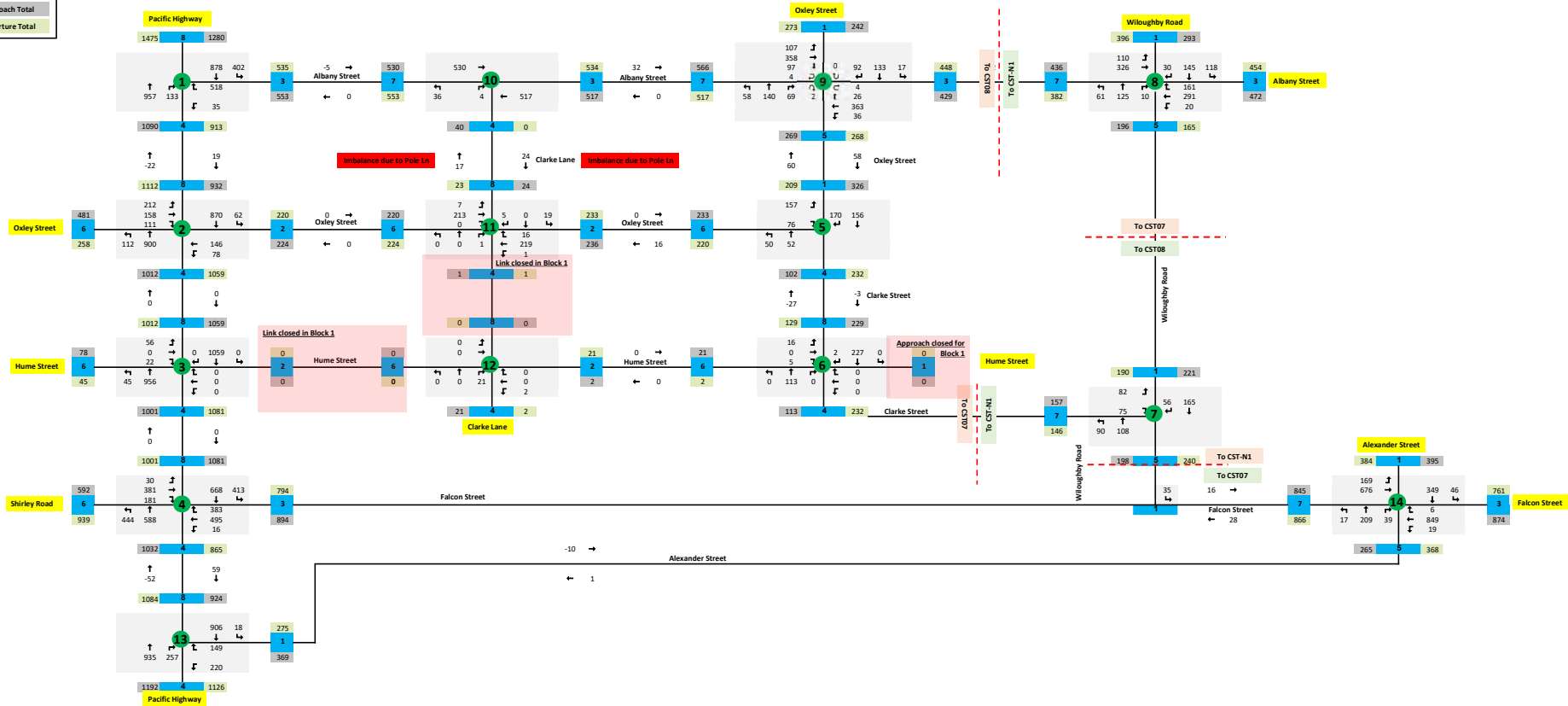

**Block 1**

Dropdowns:

Vehicle Type:

ALL VEHICLES

Time Period:

PM

VIC-N1 - 3:00 PM (Wed)

**Legend:**

Approach Number

Approach Total

Departure Total

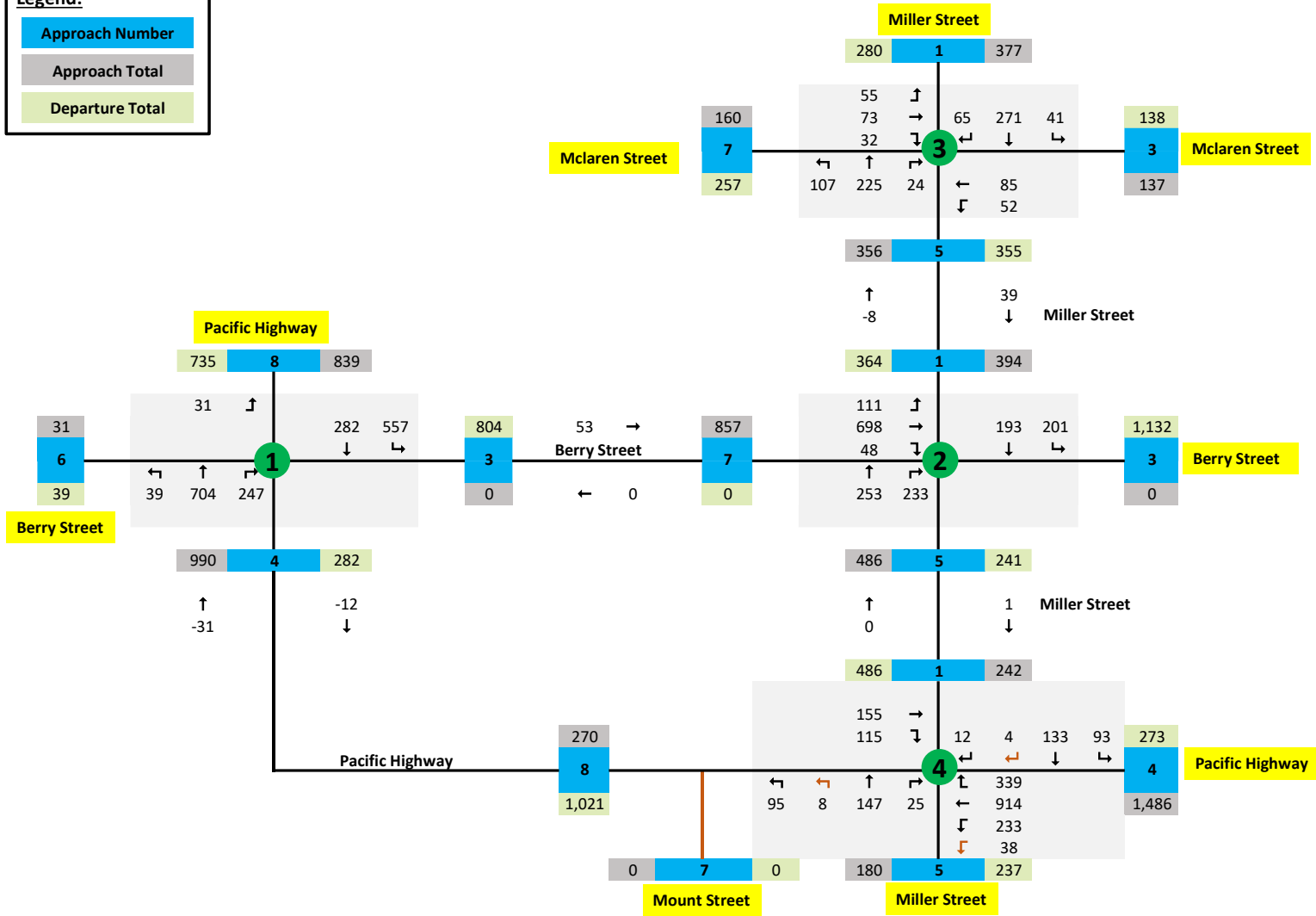

Block 1

Drops: 0

Vehicle Type:

ALL VEHICLES

Time Period:

PM

BGU-N1: 5:15 PM (Wed)

BGU-N2: 5:30 PM (Thu)

BGU-N3: 5:30 PM (Thu)

BGU-N4: 5:30 PM (Thu)

Legend:

Approach Number

Approach Total

Departure Total

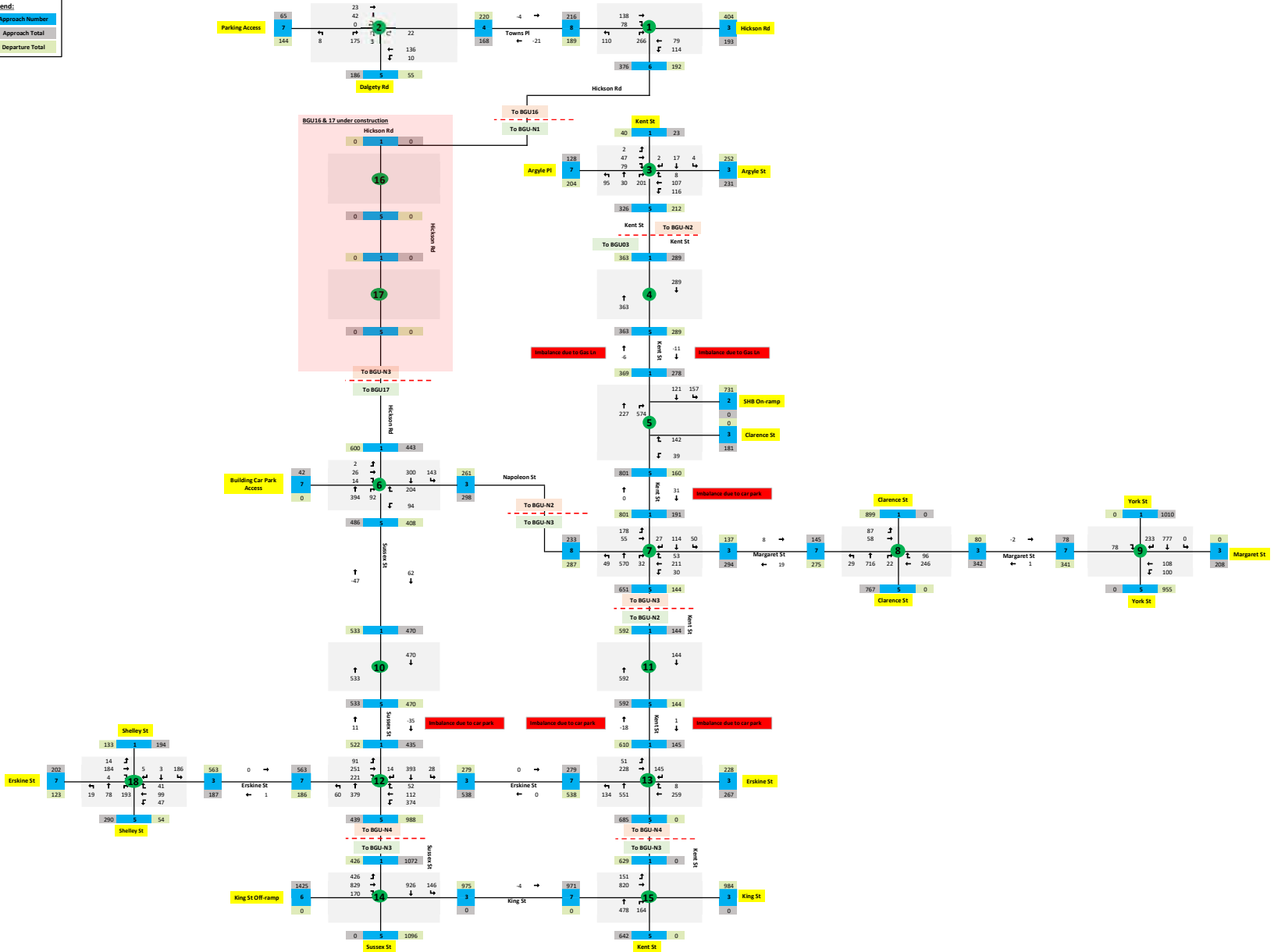

Block 1

Dropdown:

Vehicle Type:

Cyclists

Scenario:

BALANCED

Time Period:

17:00 - 18:00

BGU-N1: 5:15 PM (Wed)

BGU-N2: 5:30 PM (Thu)

BGU-N3: 5:30 PM (Thu)

BGU-N4: 5:30 PM (Thu)

Legend:

Approach Number

Approach Total

Departure Total

17:00 - 18:00

BGU-N1

BGU-N2

BGU-N3

BGU-N4

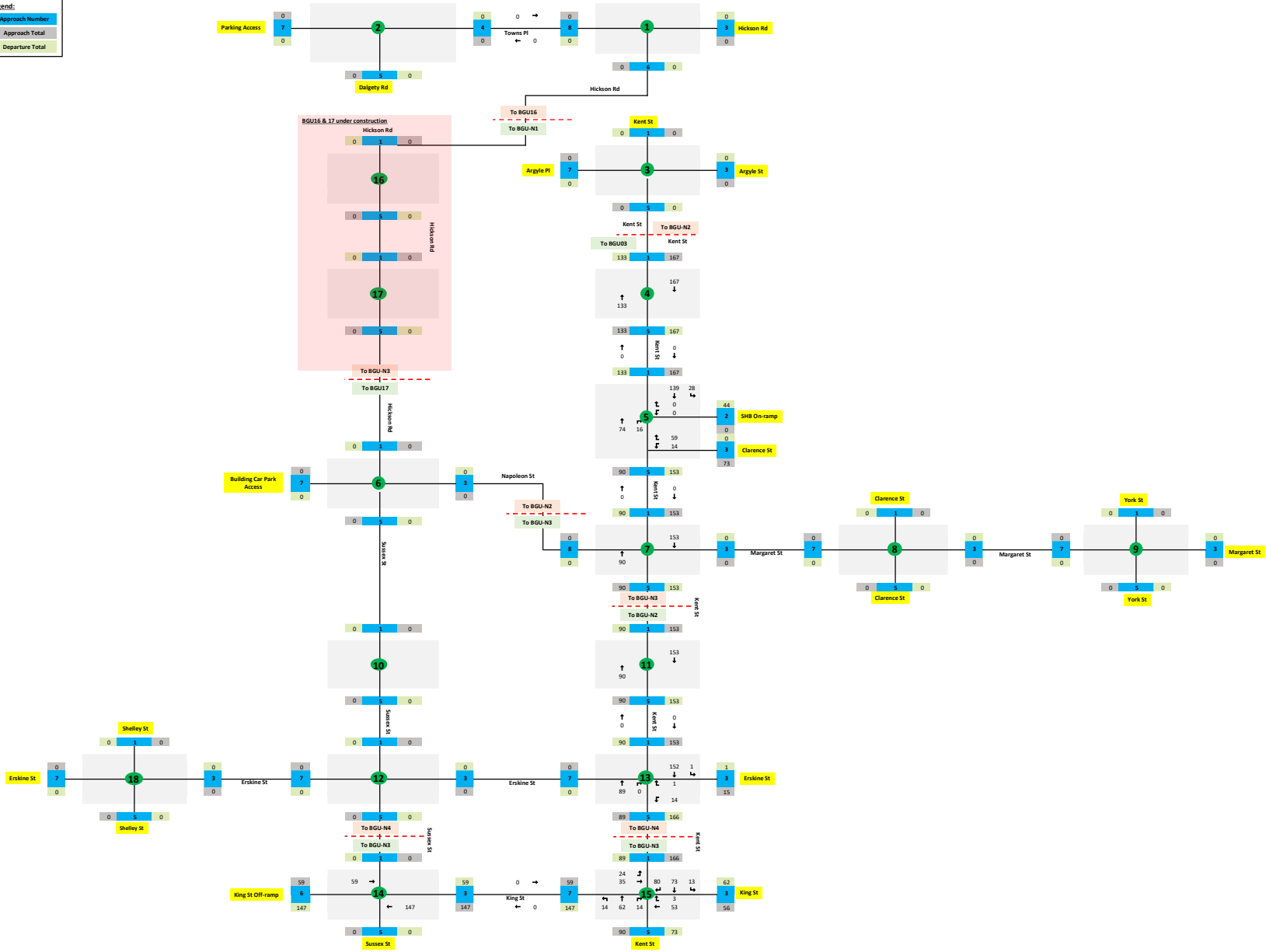

**Block 1**

Dropdowns:

Vehicle Type:

ALL VEHICLES

Time Period:

PM

MPL-N1 - 5:30 PM (Wed)

MPL05 - 6:00 PM (Fri)

MPL06 - 5:15 PM (Wed)

**Legend:**

- Approach Number
- Approach Total
- Departure Total

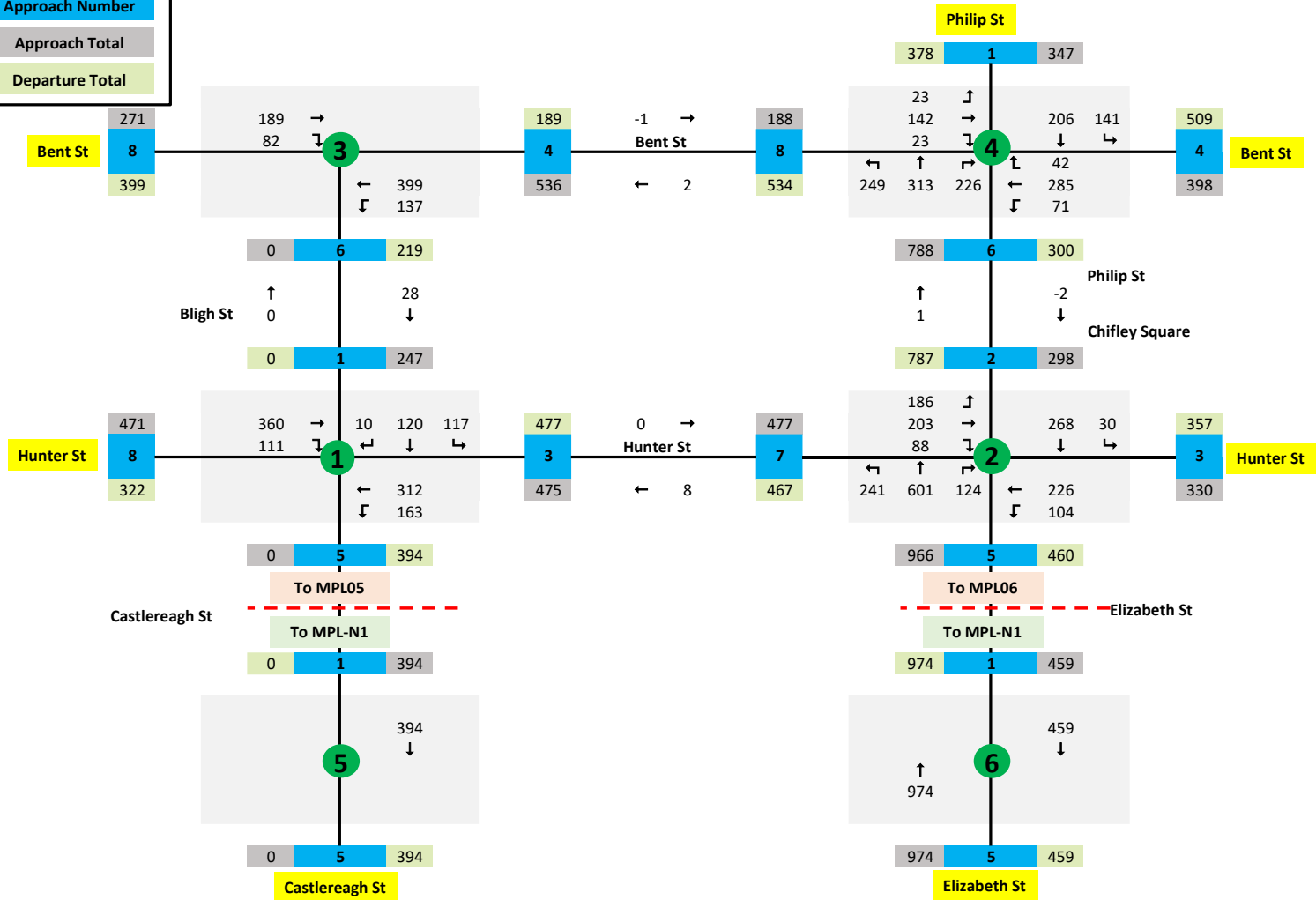



**Block 1**

Dropdowns:

Vehicle Type:

ALL VEHICLES

Time Period:

PM

PIT-N1 - 4:45 PM (Thu)

**Legend:**

Approach Number

Approach Total

Departure Total

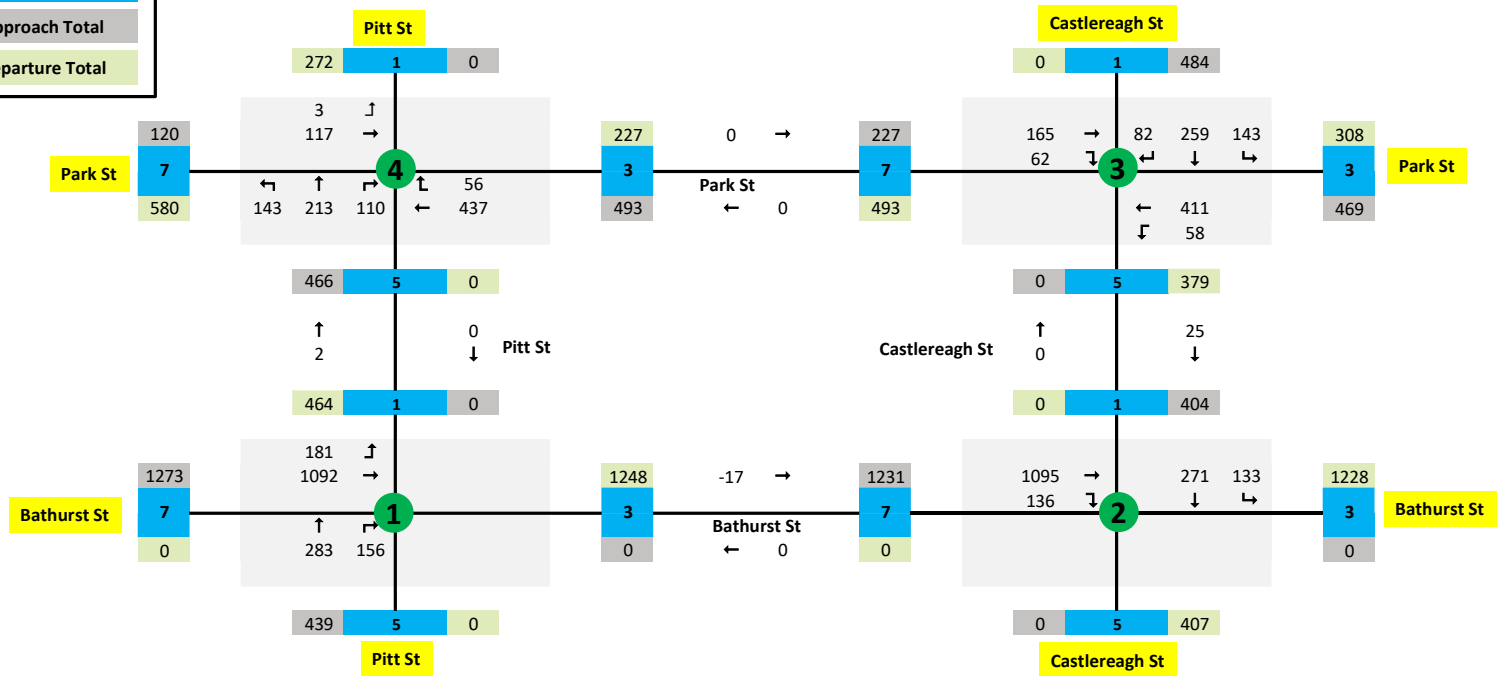

**Block 1**

Dropdowns:

Vehicle Type:

ALL VEHICLES

Time Period:

PM

CEN-N1 - 5:15 PM (Wed)

CEN-N2 - 5:30 PM (Thu)

**Legend:**

Approach Number

Approach Total

Departure Total

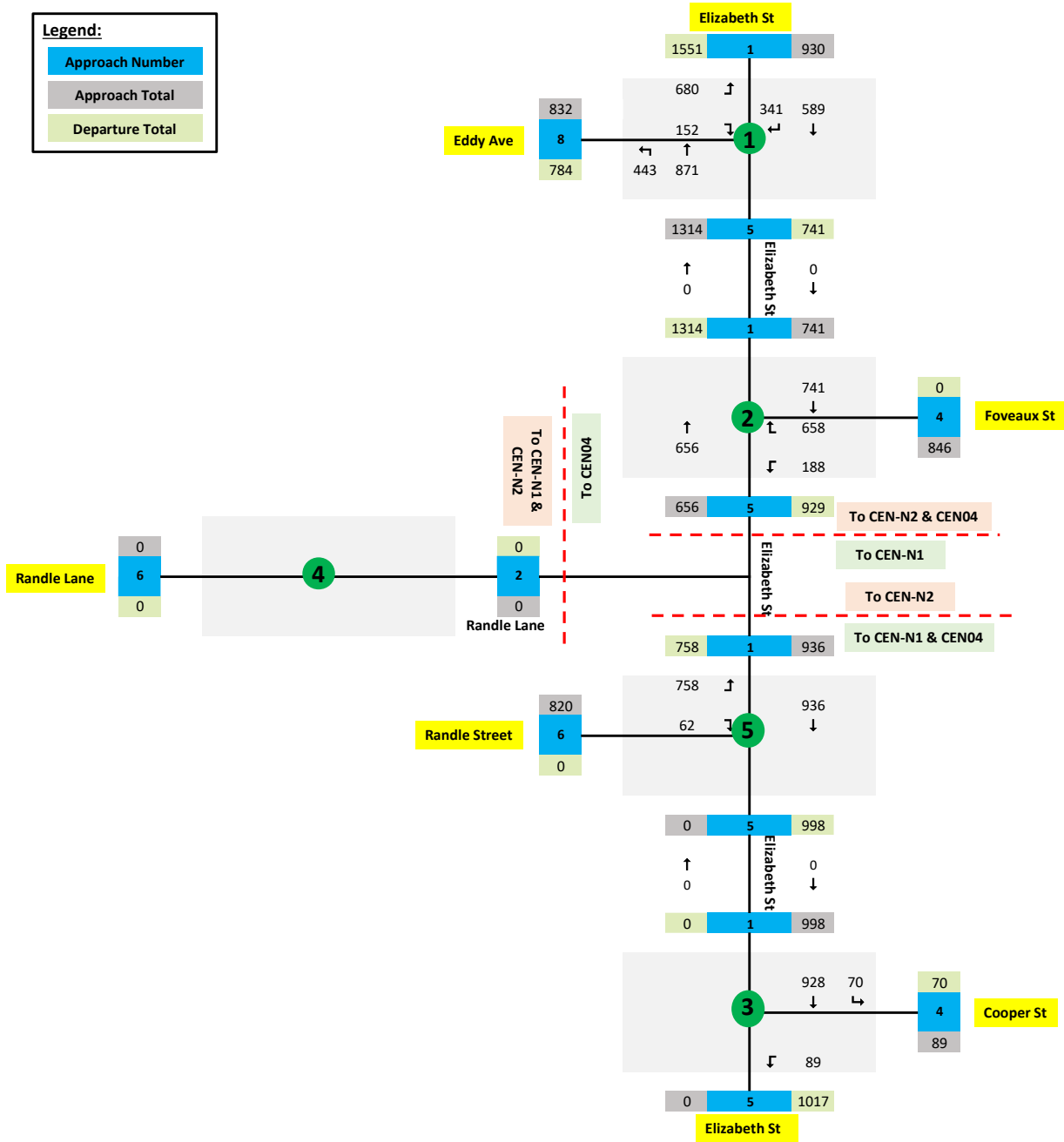

**Block 1**

Dropdowns:  
 Vehicle Type: ALL VEHICLES  
 Time Period: PM  
 WLO-N1 - 5:00 PM (Wed)

**Legend:**

- Approach Number
- Approach Total
- Departure Total

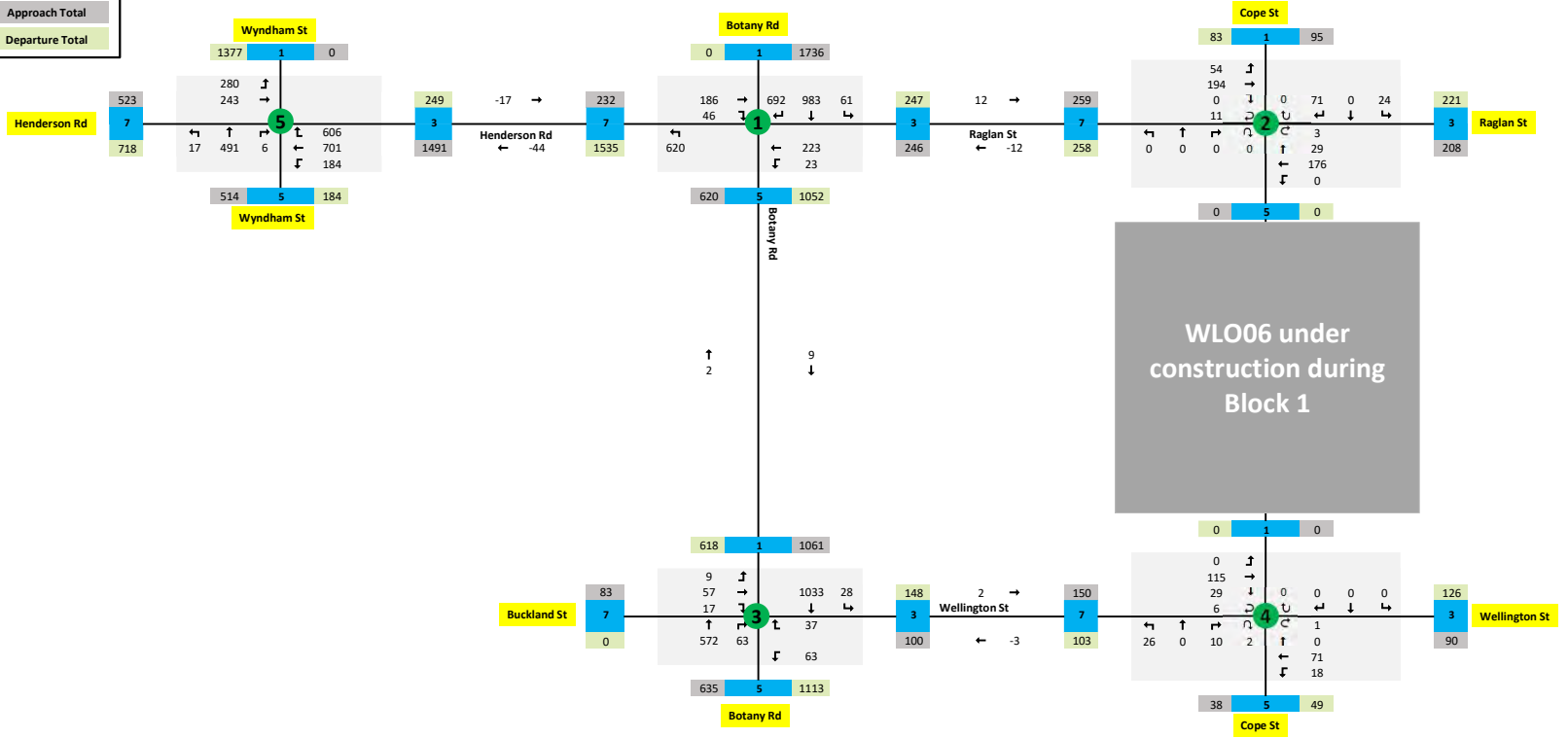

Block 1

Dropdowns:

Vehicle Type:

ALL VEHICLES

Time Period:

PM

SYD-N1 - 3:30 PM (Wed)

SYD03 - 3:45 PM (Tue)

SYD04 - 4:15 PM (Tue)

SYD05 - 4:45 PM (Tue)

SYD06 - 3:15 PM (Fri)

Legend:

Approach Number

Approach Total

Departure Total

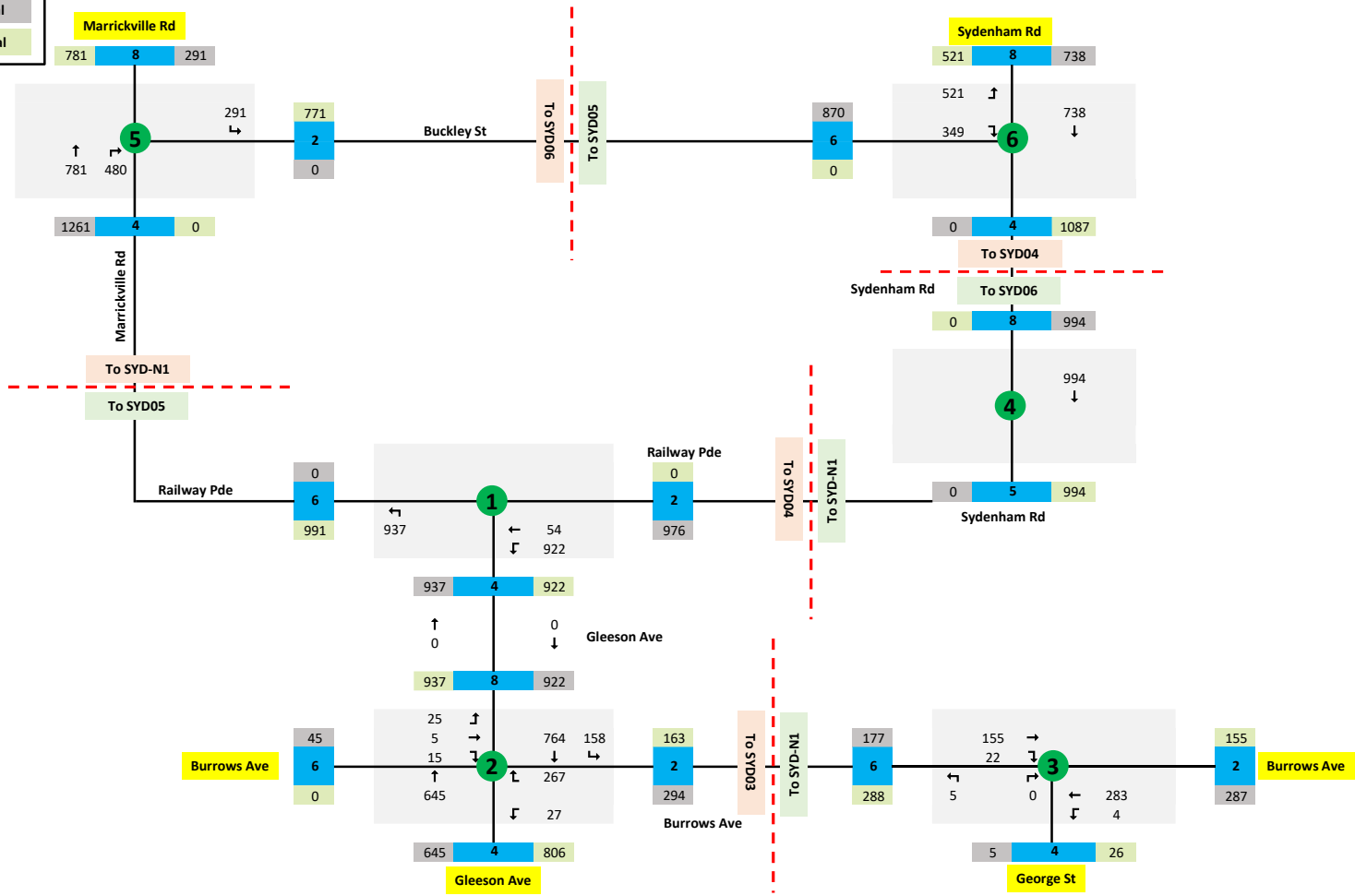

**Block 1**

Dropdowns:

Vehicle Type:

ALL VEHICLES

Time Period:

WEEKEND

CWD01 - 11:15 AM (Sat)

CWD02 - 12:30 PM (Sat)

**Legend:**

- Approach Number
- Approach Total
- Departure Total

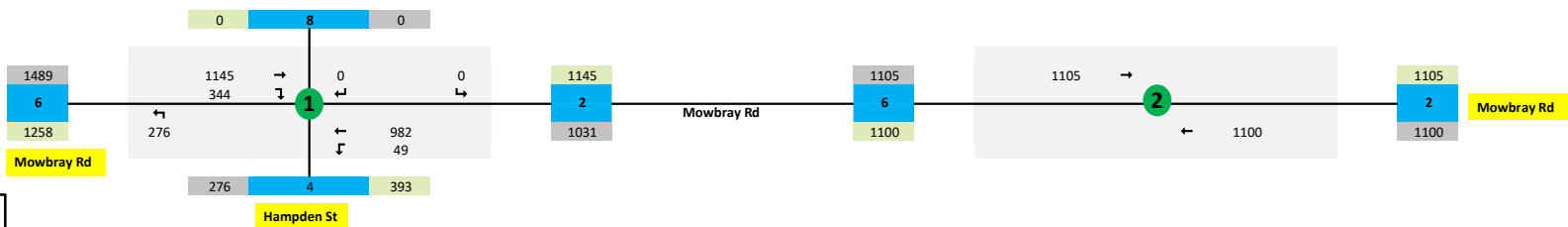



Block 1  
 Dropdowns:  
 Vehicle Type: ALLVEHICLES  
 Time Period: WEEKEND  
 CST-N1 - 11:30 AM (Sat)  
 CST07 - 11:45 AM (Sat)  
 CST08 - 11:30 AM (Sat)

Legend:

|  |                 |
|--|-----------------|
| <span style="background-color: #ADD8E6; border: 1px solid black; padding: 2px;"> </span> | Approach Number |
| <span style="background-color: #ADD8E6; border: 1px solid black; padding: 2px;"> </span> | Approach Total  |
| <span style="background-color: #D3D3D3; border: 1px solid black; padding: 2px;"> </span> | Departure Total |

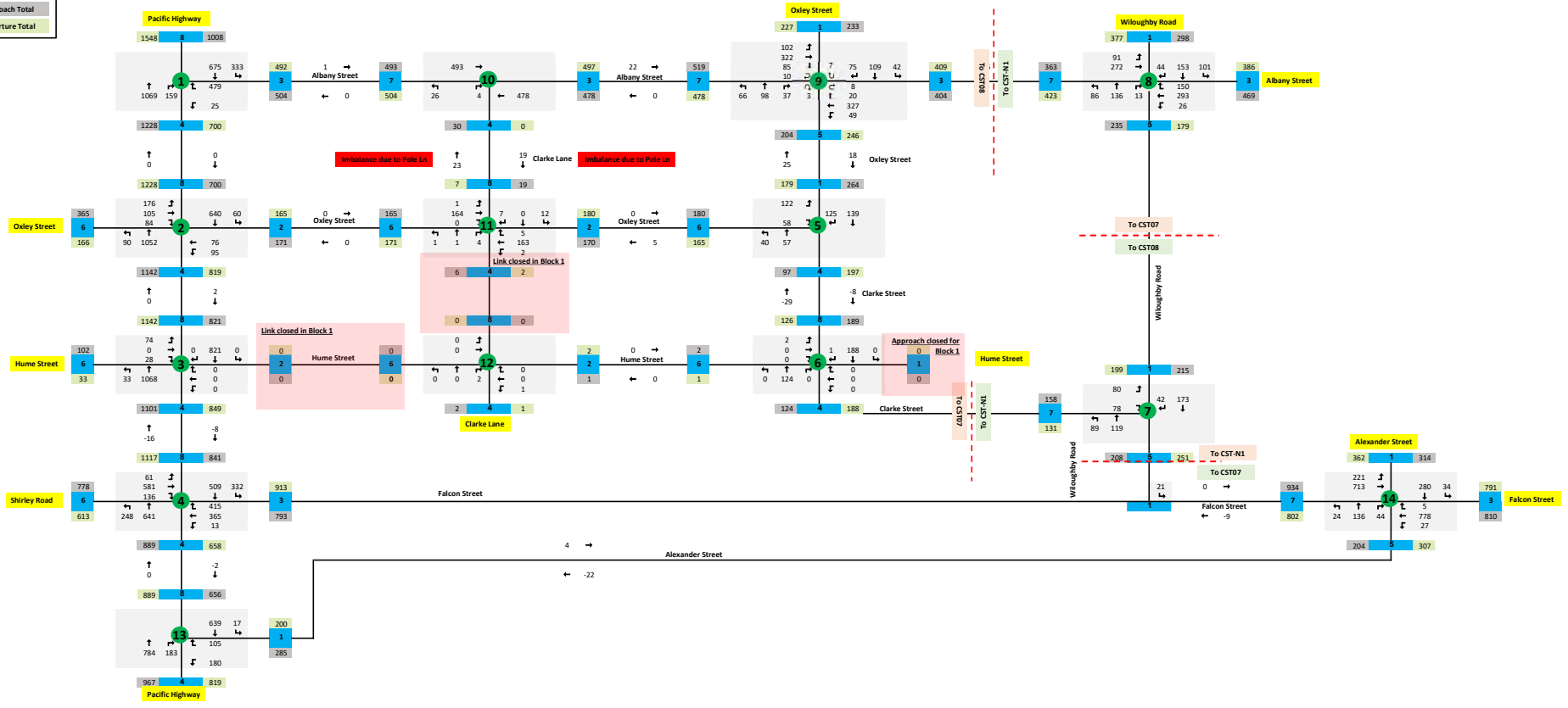

**Block 1**

Dropdowns:

Vehicle Type:

ALL VEHICLES

Time Period:

WEEKEND

VIC-N1 - 11:30 AM (Sat)

**Legend:**

Approach Number

Approach Total

Departure Total

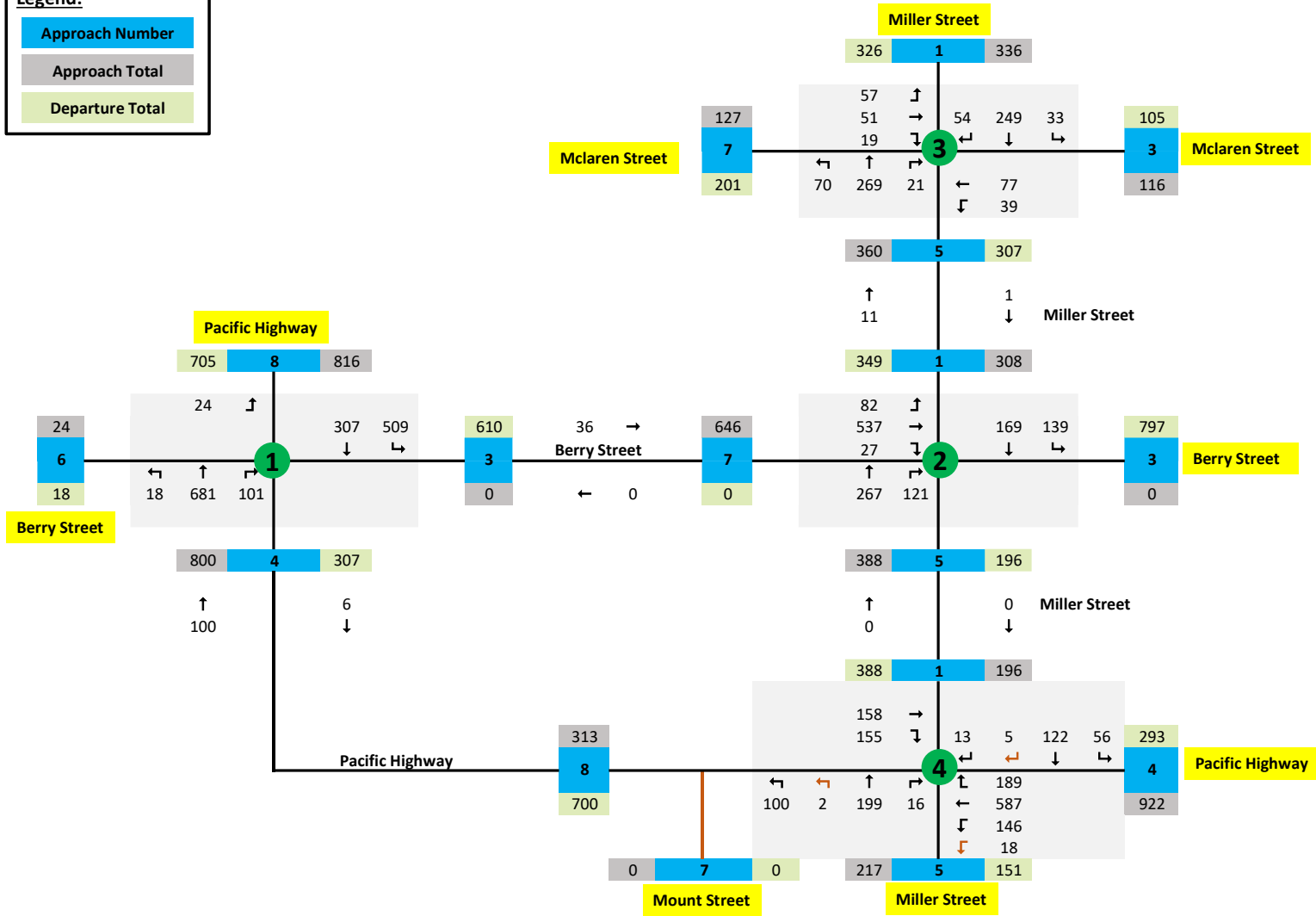

Block 1

Droptouts:

Vehicle Type:

ALL VEHICLES

Time Period:

WEEKEND

BGU-N1 - 1:15 PM (Sat)

BGU-N2 - 12:15 PM (Sat)

BGU-N3 - 12:15 PM (Sat)

BGU-N4 - 12:15 PM (Sat)

Legend:

Approach Number

Approach Total

Departure Total

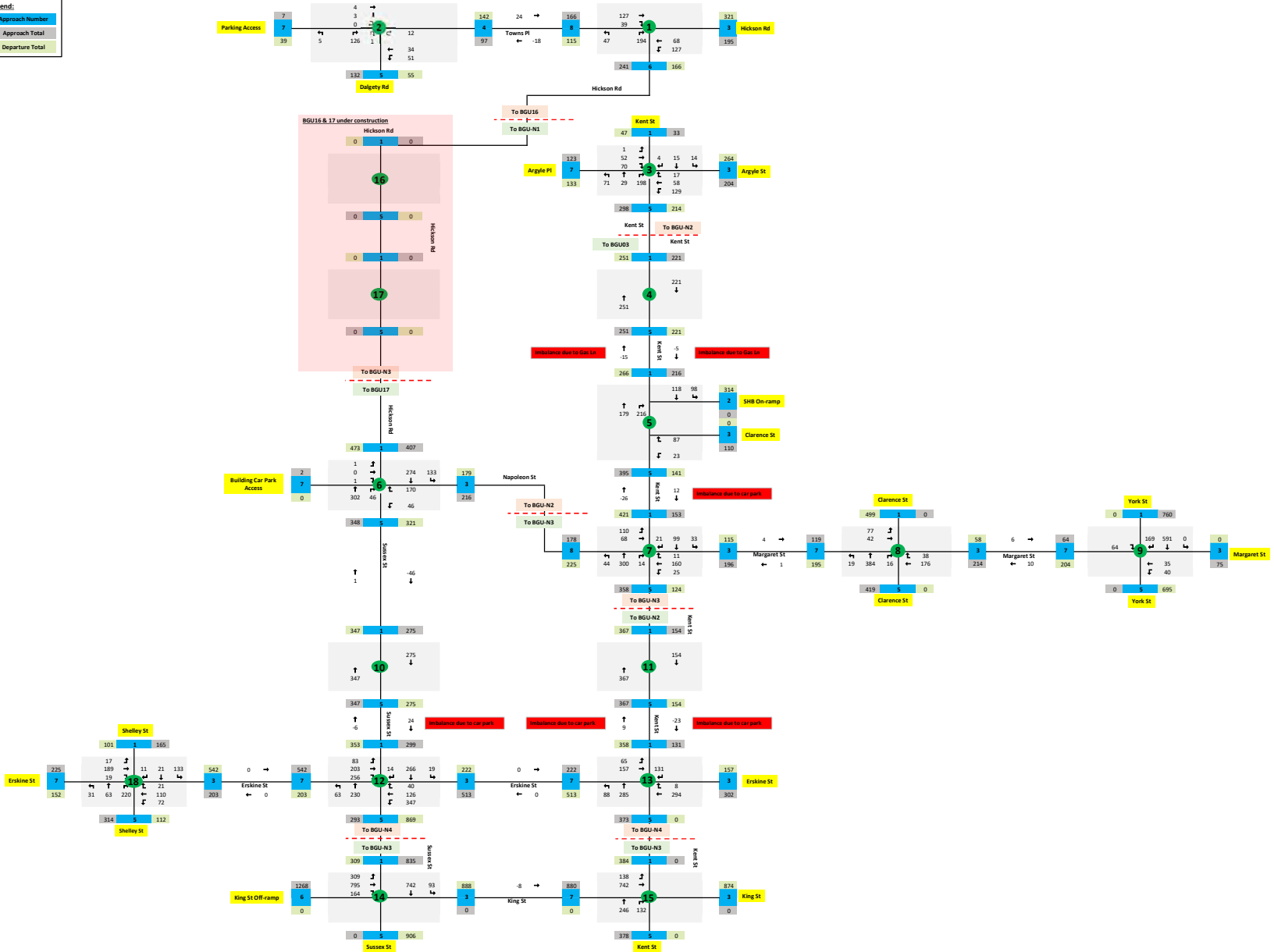

Block 1

- Dropdown:  
 Vehicle Type:  
 Cyclists  
 Scenario: BALANCED  
 Time Period: MIDDAY  
 BGL-N1 - 1:15 PM (Sat)  
 BGL-N2 - 12:15 PM (Sat)  
 BGL-N3 - 12:15 PM (Sat)  
 BGL-N4 - 12:15 PM (Sat)

Legend:

|   |                 |
|---|-----------------|
| <span style="background-color: #00aaff; color: white; padding: 2px;"> </span> | Approach Number |
| <span style="background-color: #cccccc; color: black; padding: 2px;"> </span> | Approach Total  |
| <span style="background-color: #e0e0e0; color: black; padding: 2px;"> </span> | Departure Total |

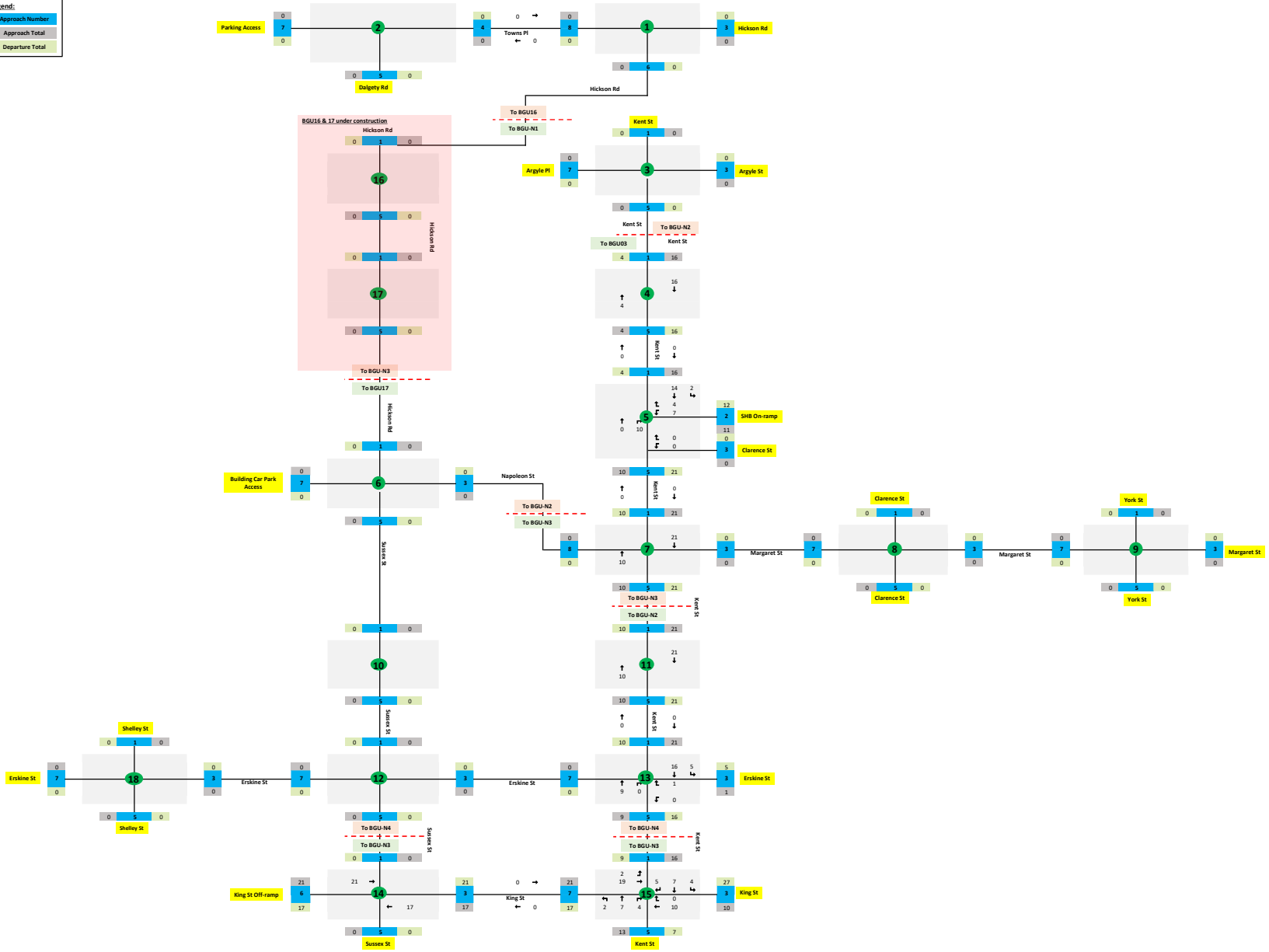

**Block 1**

Dropdowns:

Vehicle Type:

ALL VEHICLES

Time Period:

WEEKEND

MPL-N1 - 12:15 PM (Sat)

MPL05 - 1:30 PM (Sat)

MPL06 - 12:15 PM (Sat)

**Legend:**

- Approach Number
- Approach Total
- Departure Total

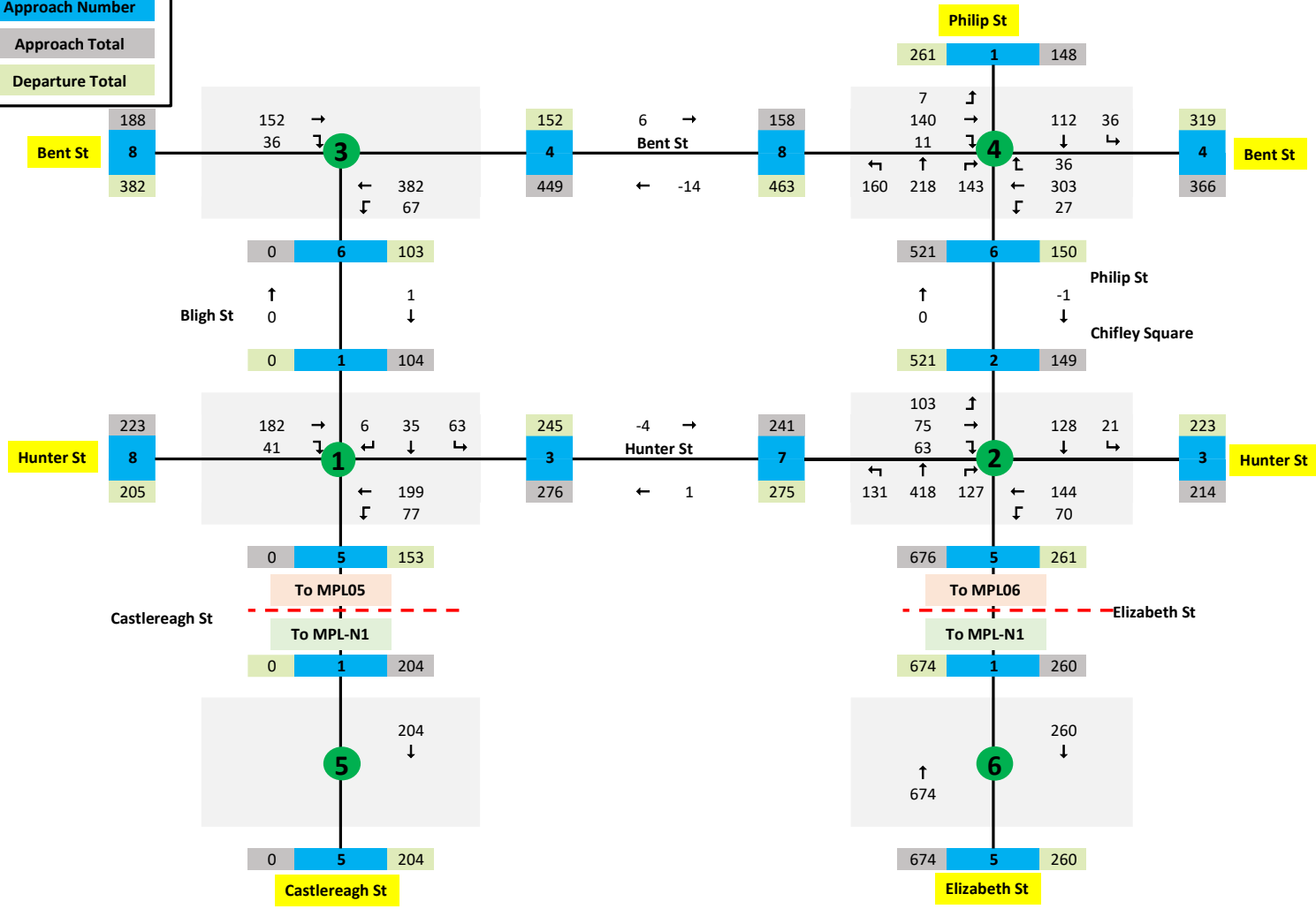



**Block 1**

Dropdowns:

Vehicle Type:

ALL VEHICLES

Time Period:

WEEKEND

PIT-N1 - 12:15 PM (Sat)

**Legend:**

- Approach Number
- Approach Total
- Departure Total

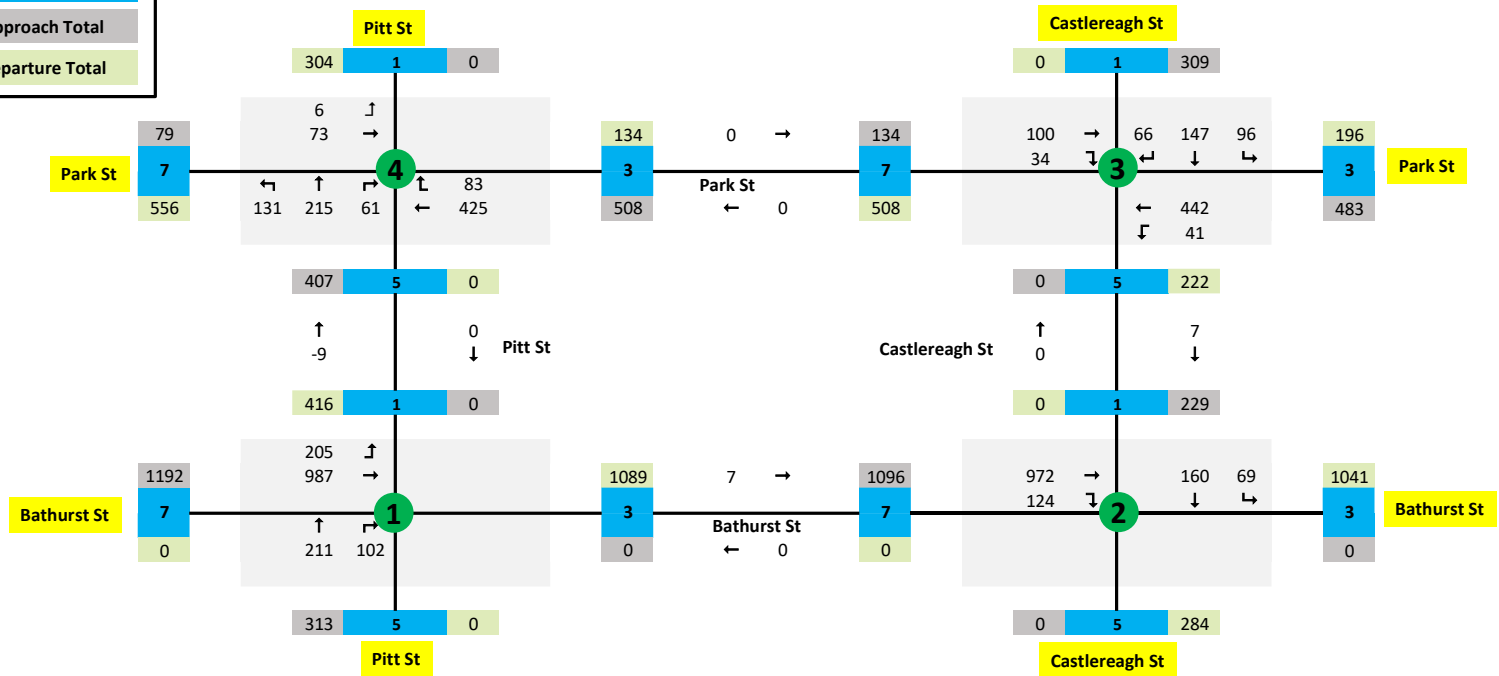

**Block 1**

Dropdowns:

Vehicle Type:

ALL VEHICLES

Time Period:

WEEKEND

CEN-N1 - 1:45 PM (Sat)

CEN-N2 - 12:00 PM (Sat)

**Legend:**

Approach Number

Approach Total

Departure Total

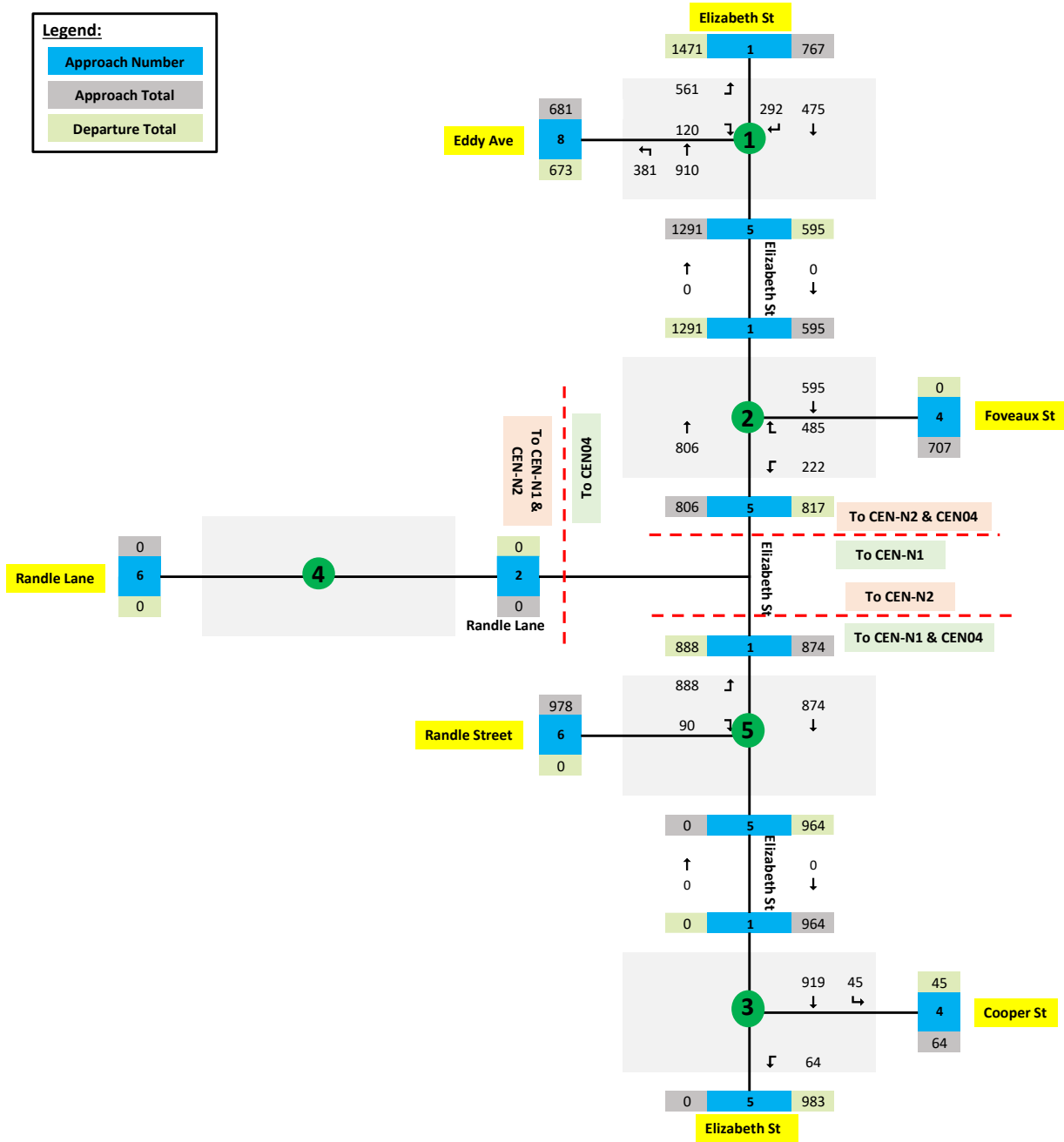

**Block 1**

Dropdowns:  
 Vehicle Type:  
 ALL VEHICLES  
 Time Period:  
 WEEKEND  
 WLO-N1 - 12:15 PM (Sat)

**Legend:**

- Approach Number
- Approach Total
- Departure Total

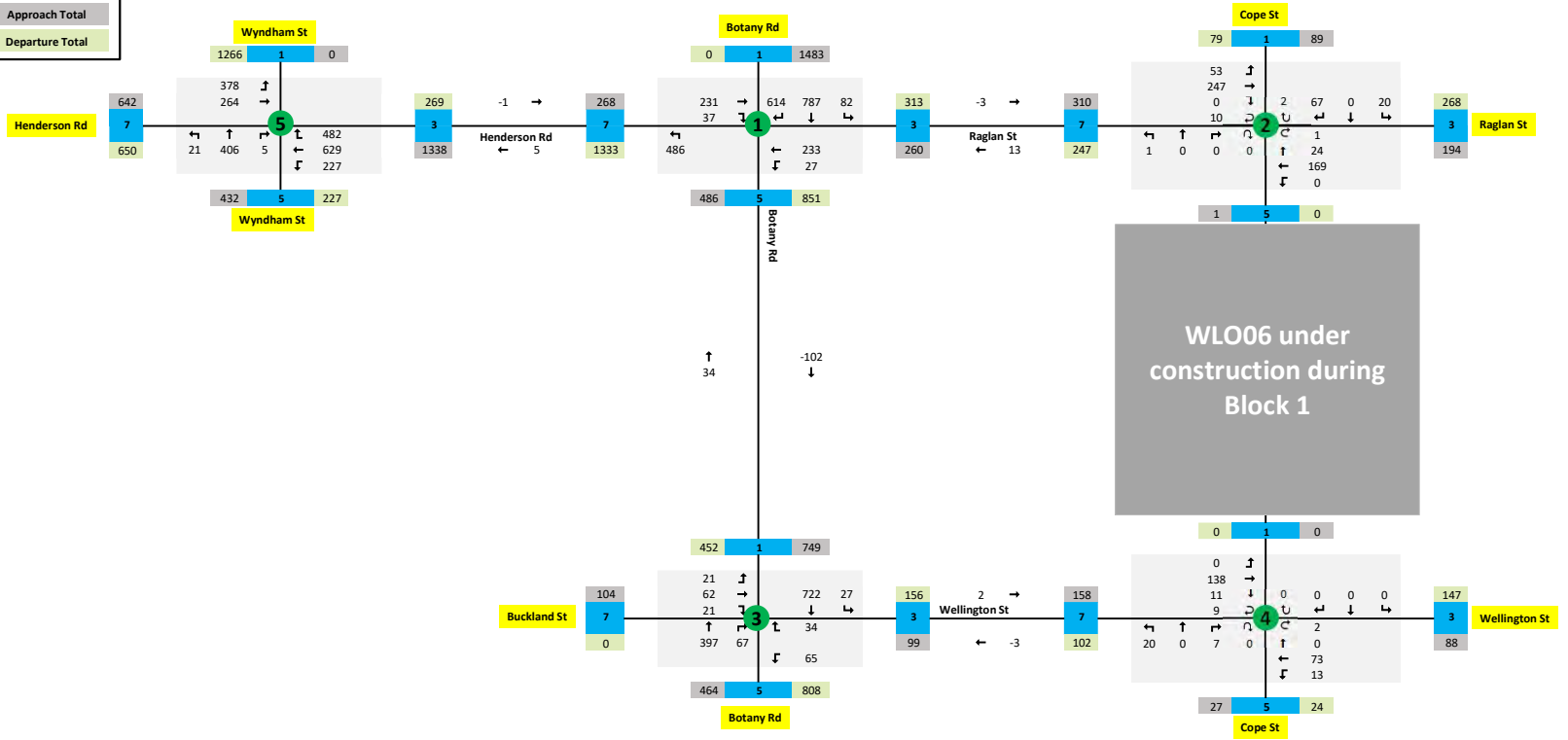

Block 1

Dropdowns:

Vehicle Type:

ALL VEHICLES

Time Period:

WEEKEND

SYD-N1 - 1:00 PM (Sun)

SYD03 - 1:00 PM (Sat)

SYD04 - 1:45 PM (Sat)

SYD05 - 1:45 PM (Sat)

SYD06 - 10:30 AM (Sat)

Legend:

Approach Number

Approach Total

Departure Total

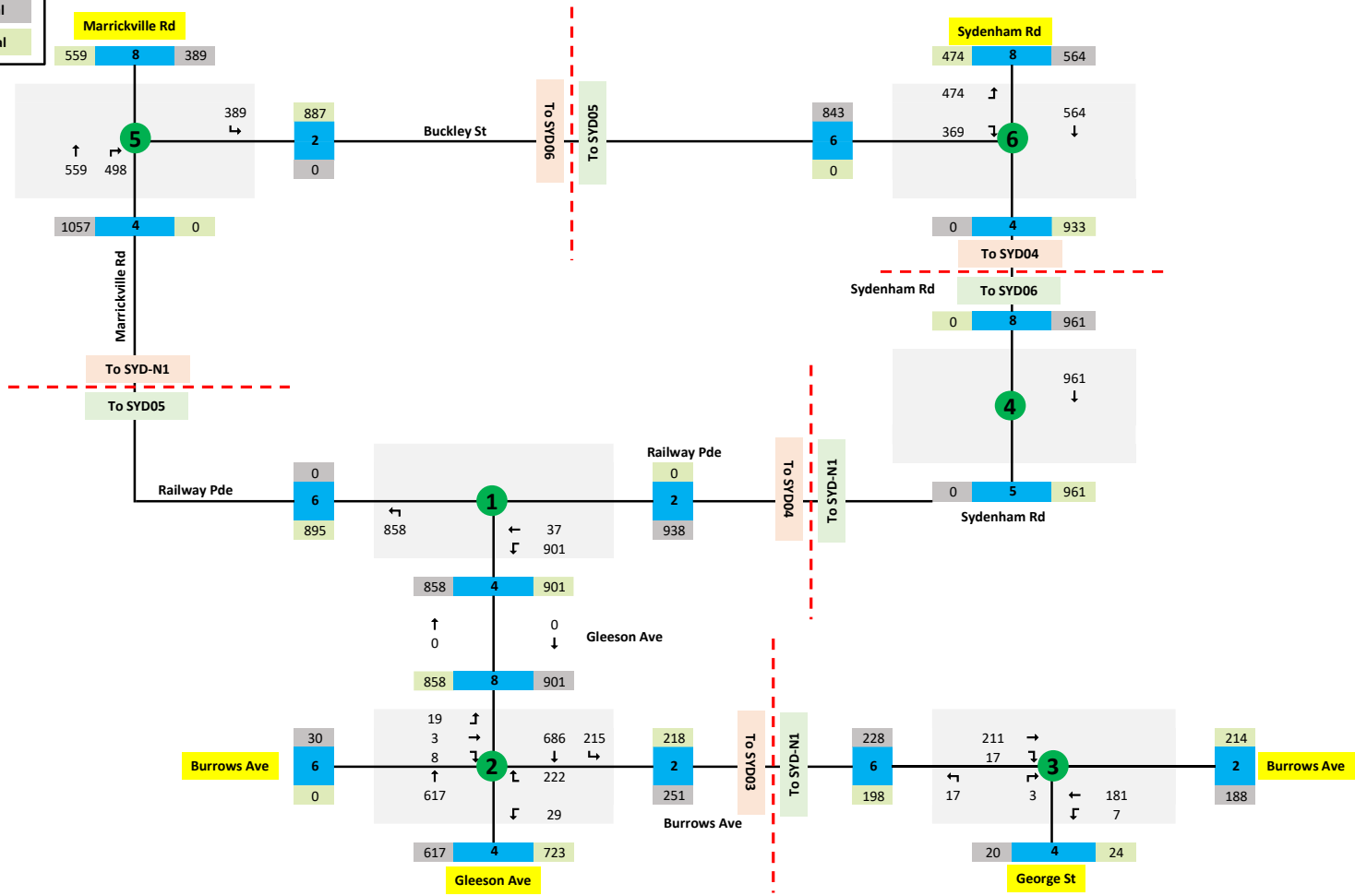

**Block 1**

Dropdowns:

Vehicle Type:

Pedestrians

Time Period:

AM

CWD01 - 8:15 AM (Wed)

CWD02 - 8:15 AM (Wed)

**Legend:**

Marked Foot Crossing



Pedestrian Crossing



Kerb Ramps Only

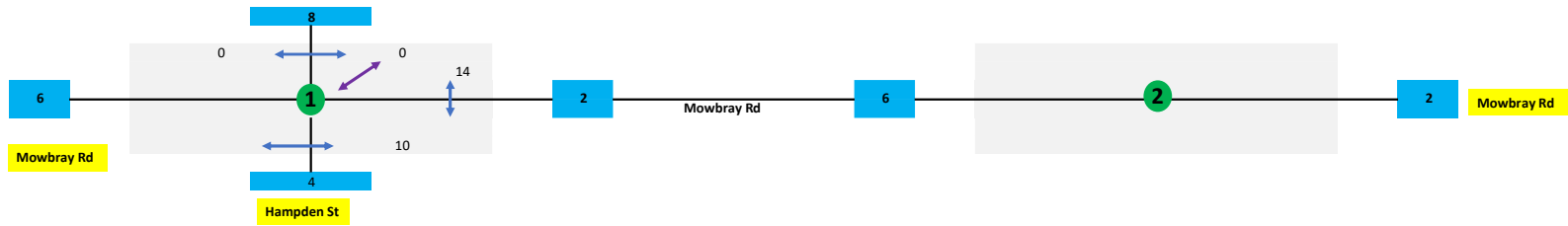

Block 1  
 Dropdown:  
 Vehicle Type:  
 Pedestrians  
 Time Period:  
 AM  
 CST-N1 - 8:15 AM (Wed)  
 CST07 - 8:30 AM (Mon)  
 CST08 - 8:15 AM (Mon)

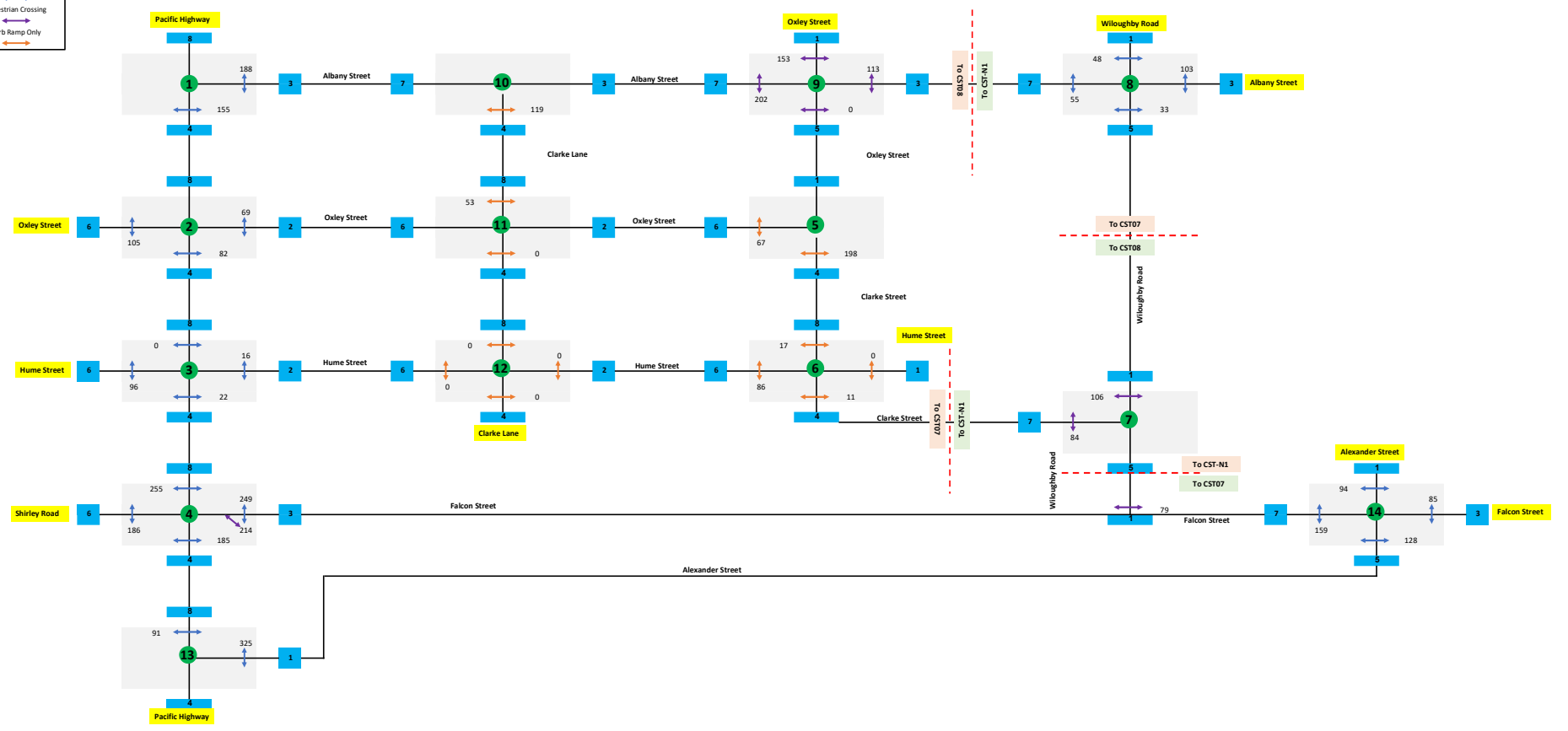



**Block 1**

Dropdowns:

Vehicle Type:

Pedestrians

Time Period:

AM

VIC-N1 - 8:45 AM (Mon)

**Legend:**

Marked Foot Crossing



Pedestrian Crossing



Kerb Ramps Only

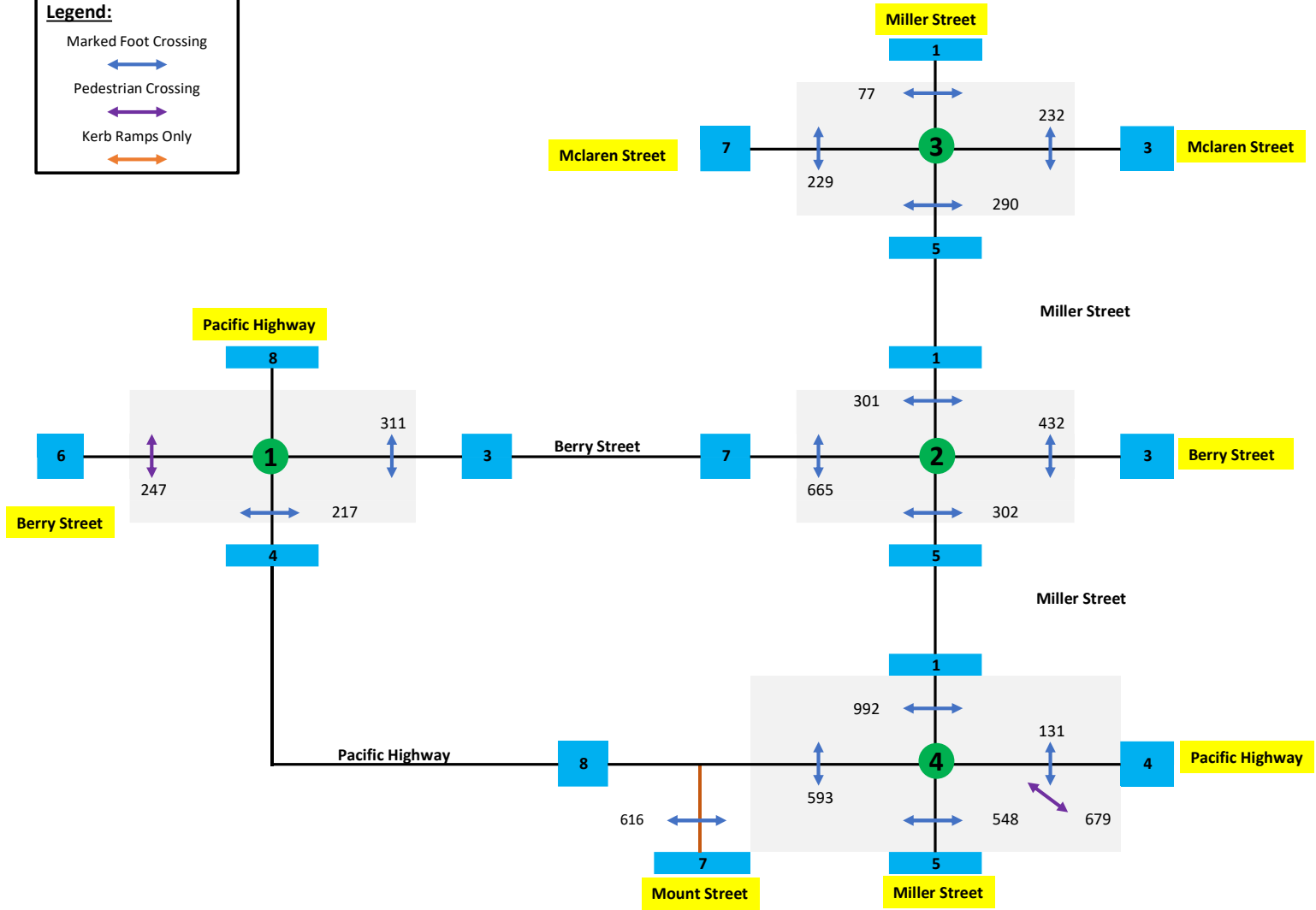

**Block 1**

- Dropoffs:
- Vehicle Type:
- Pedestrians:
- Time Period:
- AM
- BGU-N1 - 8:45 AM (Tue)
- BGU-N2 - 8:30 AM (Tue)
- BGU-N3 - 8:30 AM (Tue)
- BGU-N4 - 8:30 AM (Tue)

**Legend:**

- Marked Foot Crossing
- Pedestrian Crossing
- Keyp Ramps Only

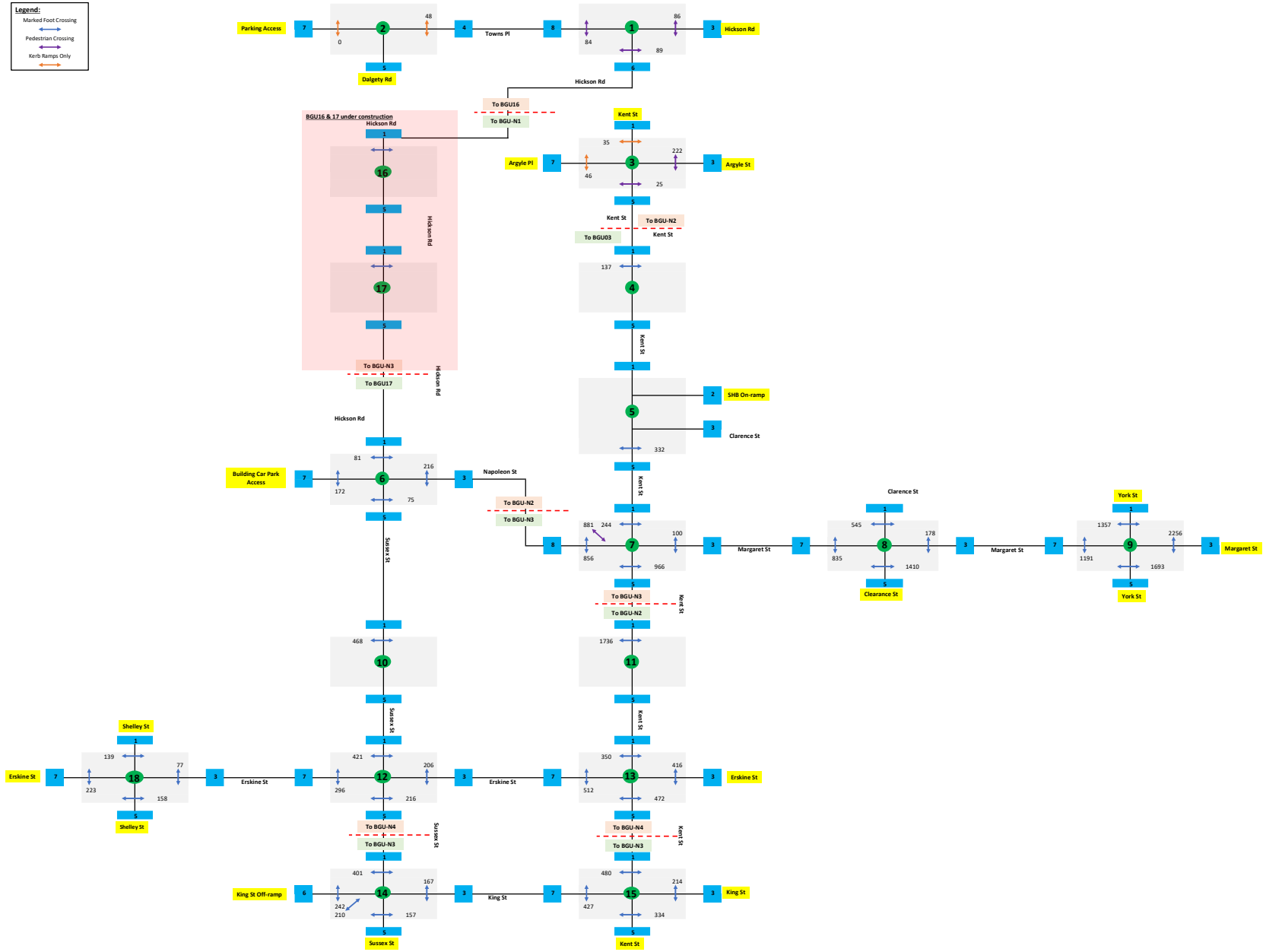

**Block 1**

Dropdowns:

Vehicle Type:

Pedestrians

Time Period:

AM

MPL-N1 - 9:00 AM (Wed)

MPL05 - 9:00 AM (Tue)

MPL06 - 8:45 AM (Wed)

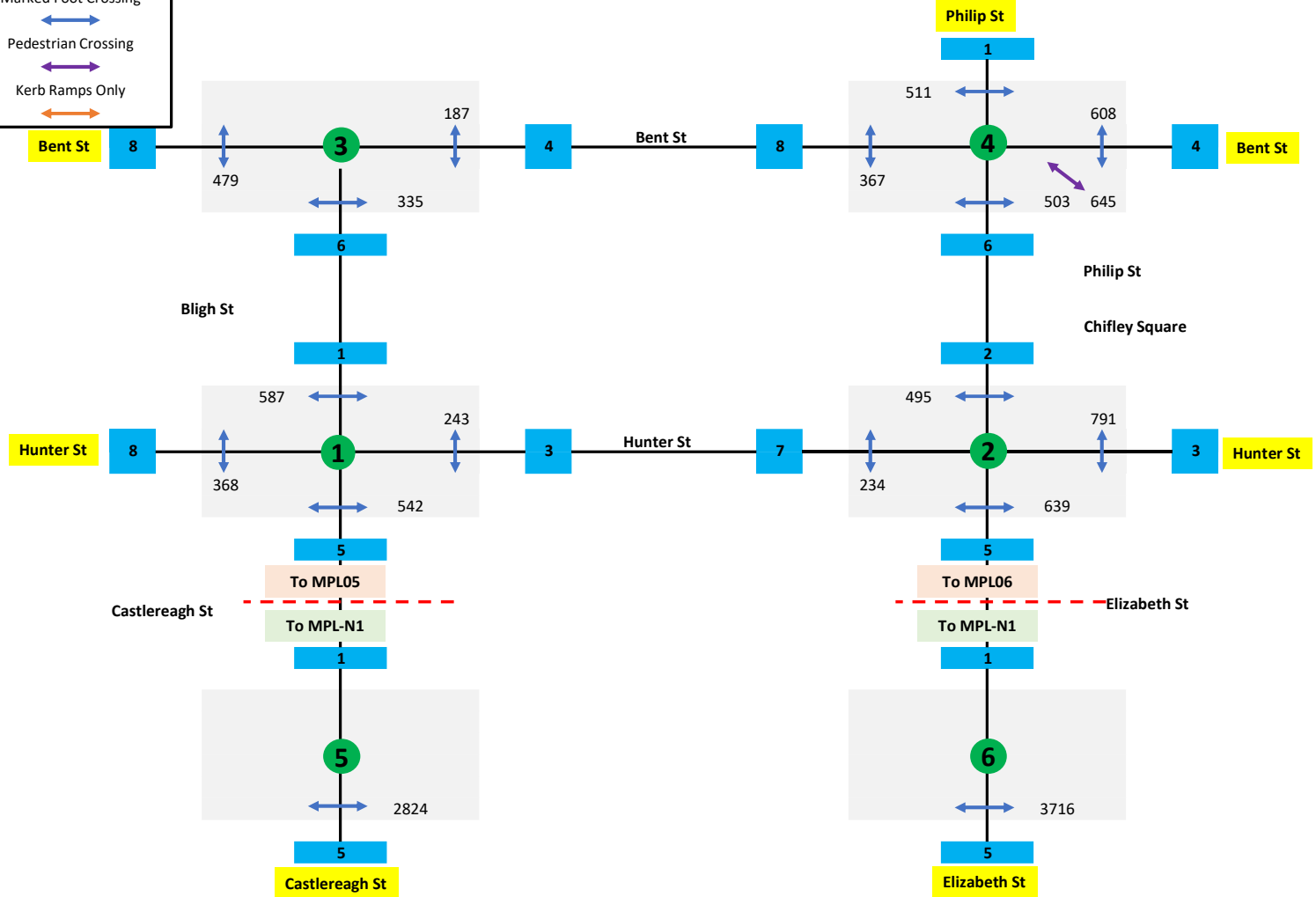
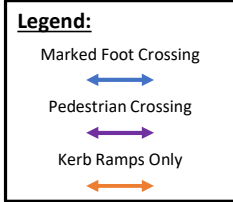

**Block 1**

Dropdowns:  
Vehicle Type:  
Pedestrians  
Time Period:  
AM  
PIT-N1 - 9:15 AM (Tue)

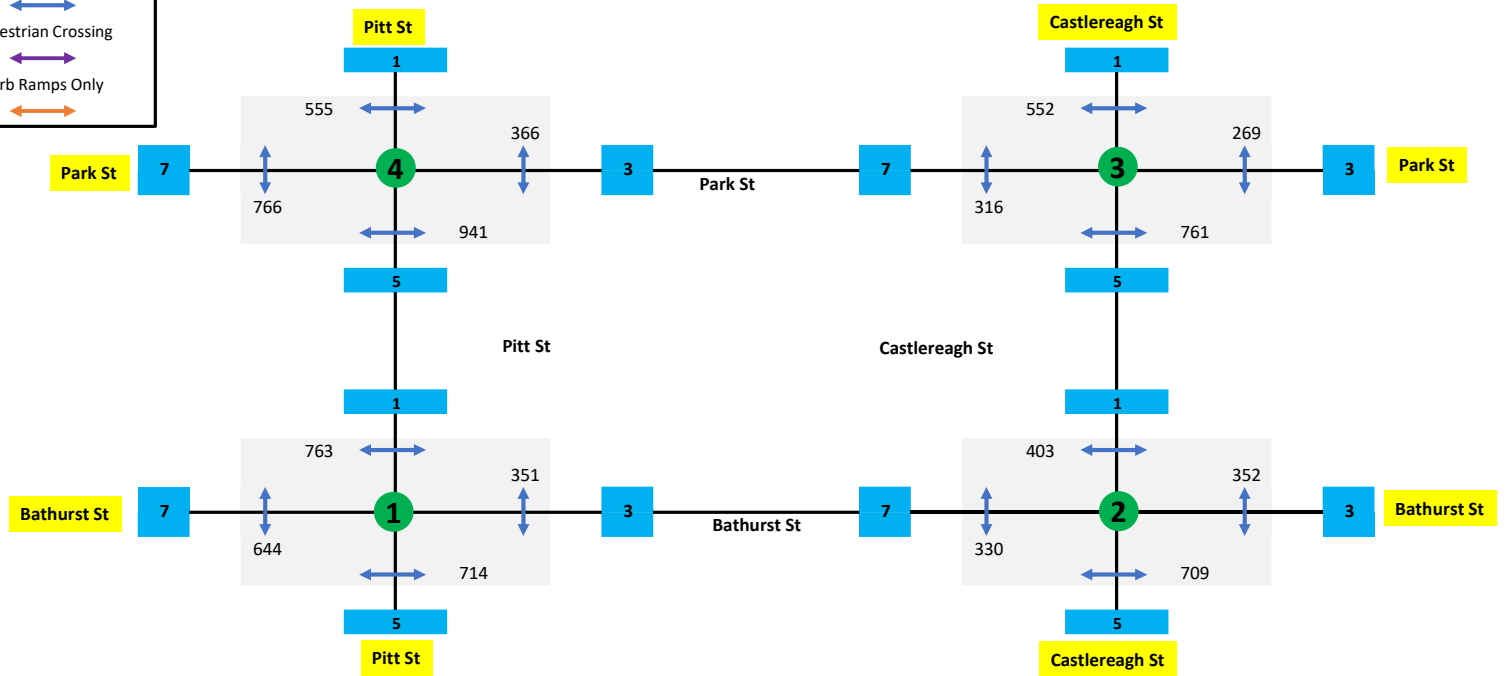
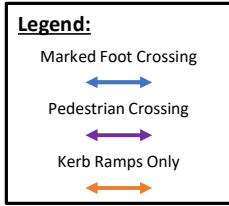

**Block 1**

Dropdowns:

Vehicle Type:

Pedestrians

Time Period:

AM

CEN-N1 - 8:15 AM (Wed)

CEN-N2 - 8:15 AM (Thu)

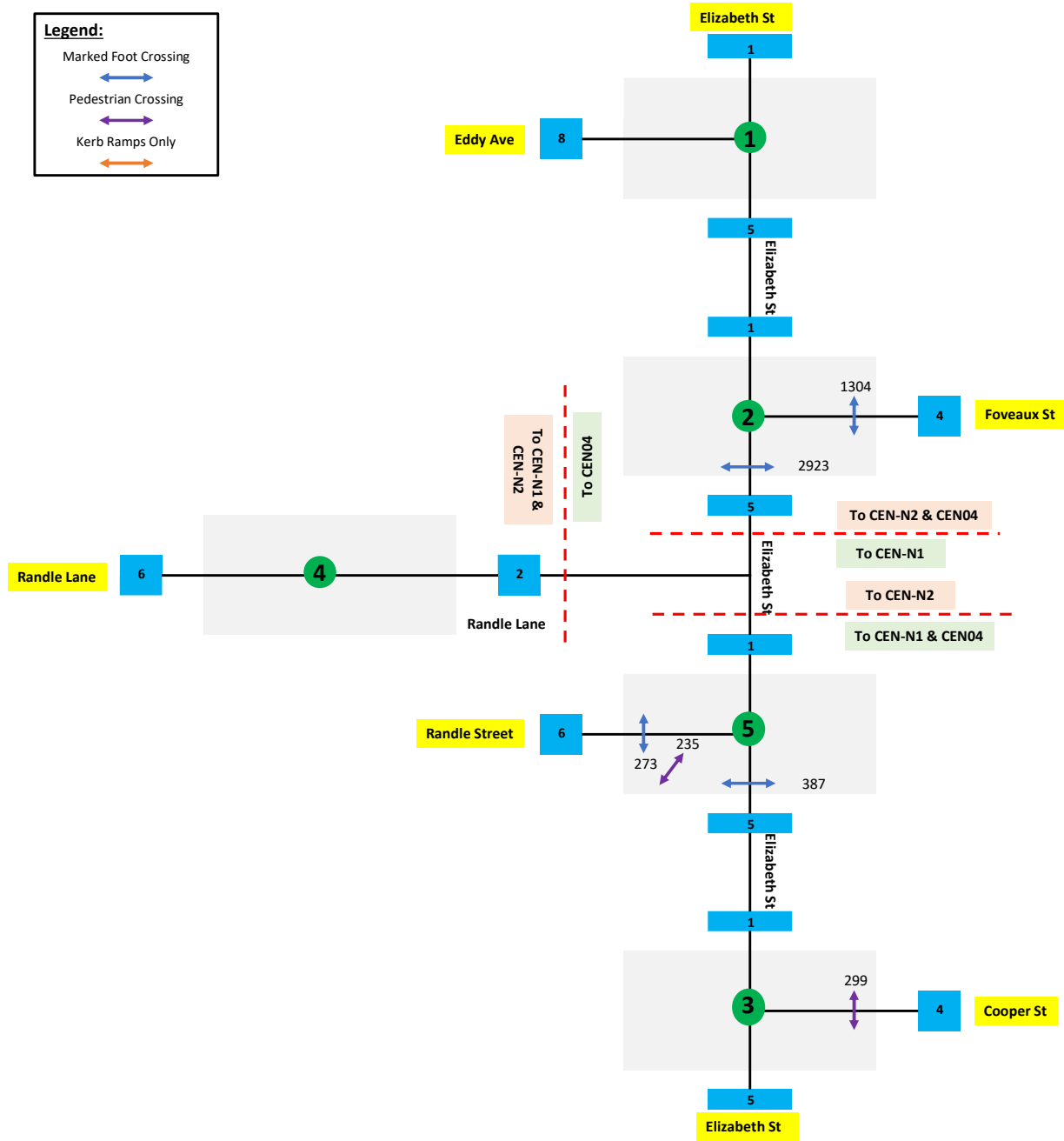
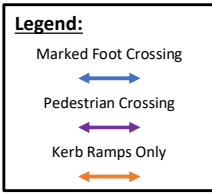

**Block 1**

Dropdowns:  
 Vehicle Type:  
 Pedestrians  
 Time Period:  
 AM  
 WLO-N1 - 8:15 AM (Wed)

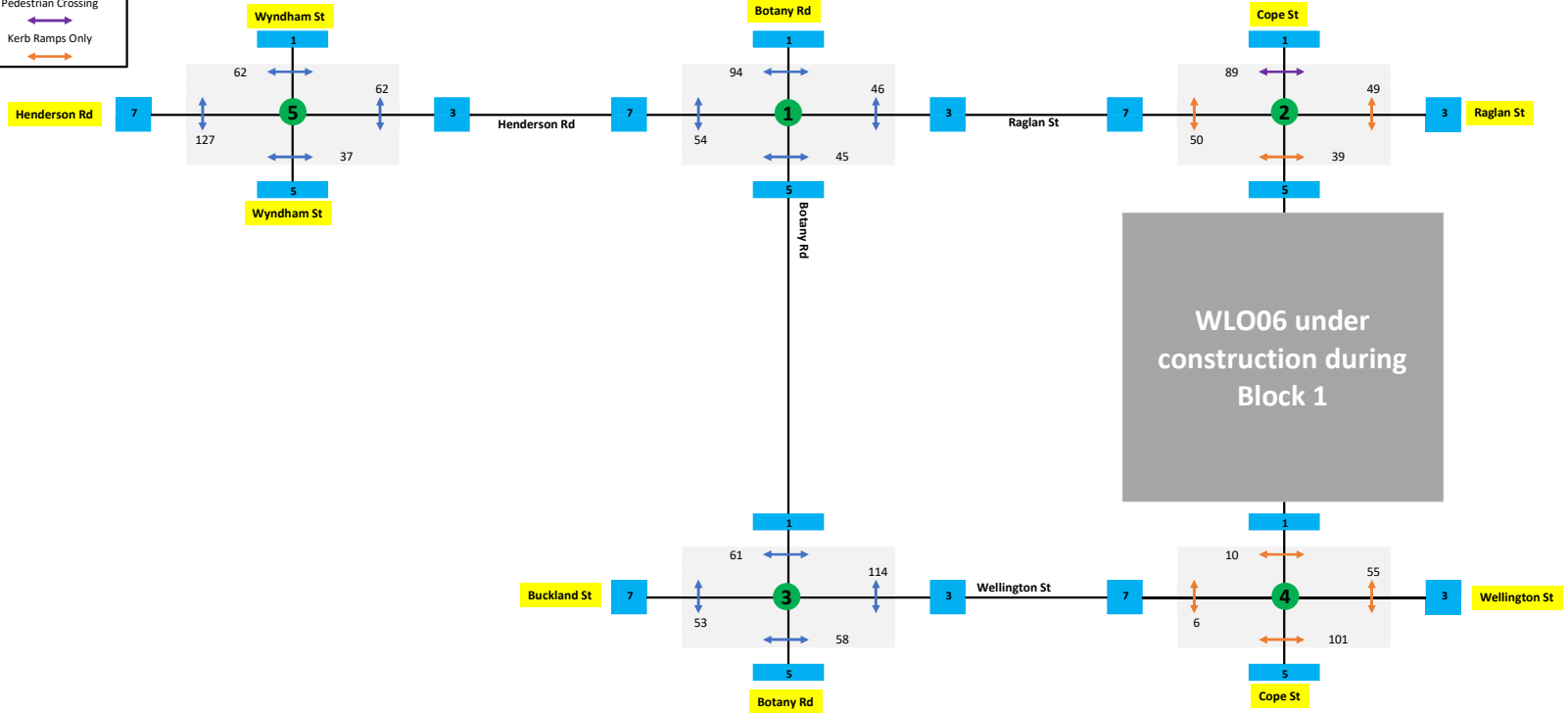
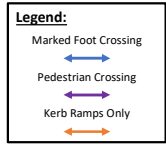



**Block 1**

Dropdowns:

Vehicle Type:

Pedestrians

Time Period:

- AM
- SYD-N1 - 7:45 AM (Wed)
- SYD03 - 7:30 AM (Tue)
- SYD04 - 8:15 AM (Tue)
- SYD05 - 8:15 AM (Tue)
- SYD06 - 8:15 AM (Tue)

**Legend:**

- Marked Foot Crossing
- Pedestrian Crossing
- Kerb Ramps Only

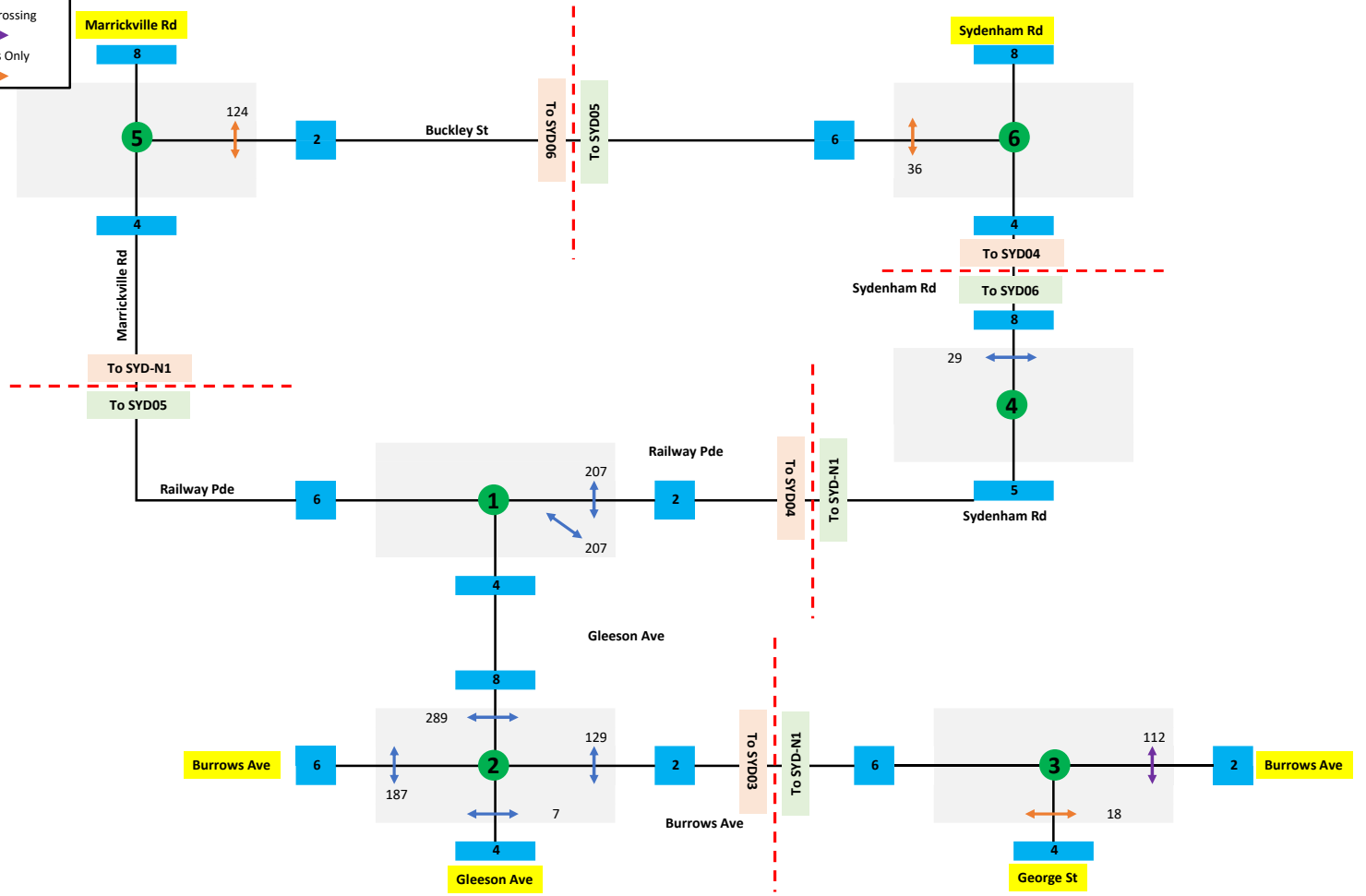

**Block 1**

Dropdowns:

Vehicle Type:

Pedestrians

Time Period:

PM

CWD01 - 3:15 PM (Fri)

CWD02 - 3:15 PM (Fri)

**Legend:**

Marked Foot Crossing



Pedestrian Crossing



Kerb Ramps Only

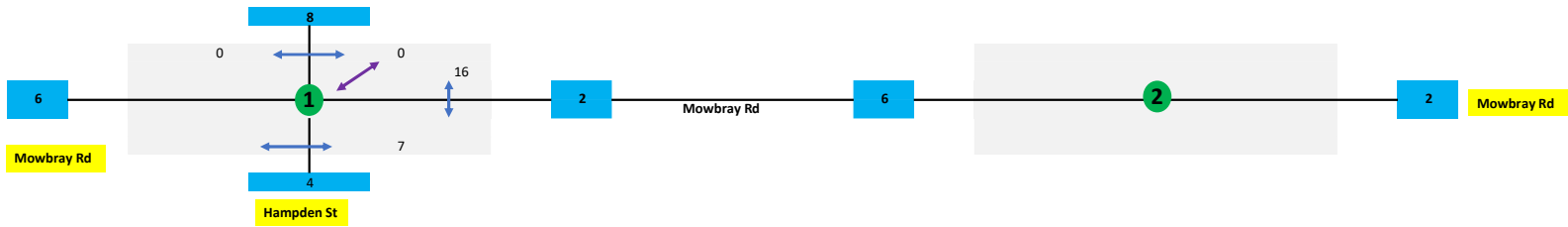

Block 1  
 Dropdown:  
 Vehicle Type:  
 Pedestrians  
 Time Period:  
 PM  
 CST-N1 - 4:45 PM (Tue)  
 CST07 - 5:45 PM (Fri)  
 CST08 - 5:00 PM (Thu)

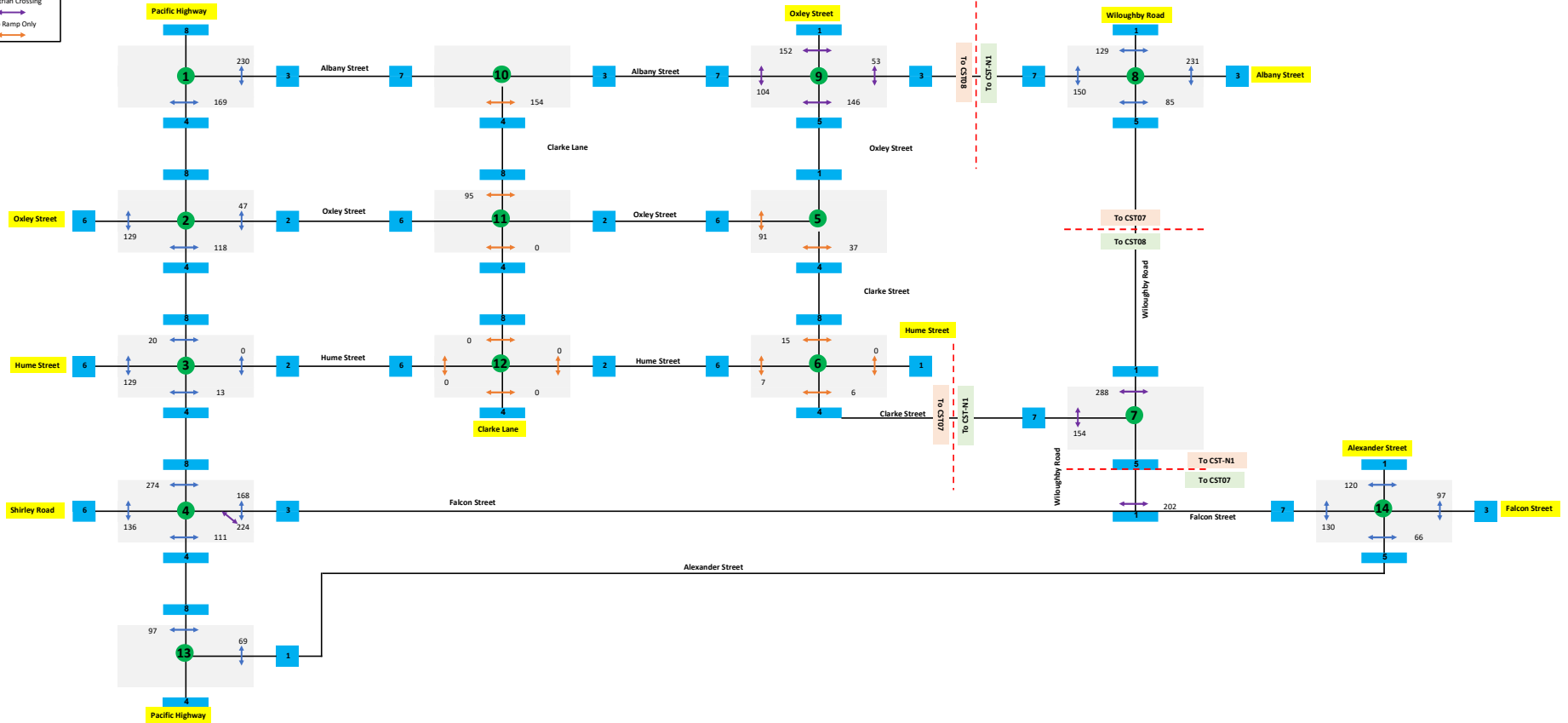

**Block 1**

Dropdowns:

Vehicle Type:

Pedestrians

Time Period:

PM

VIC-N1 - 3:00 PM (Wed)

**Legend:**

Marked Foot Crossing



Pedestrian Crossing



Kerb Ramps Only

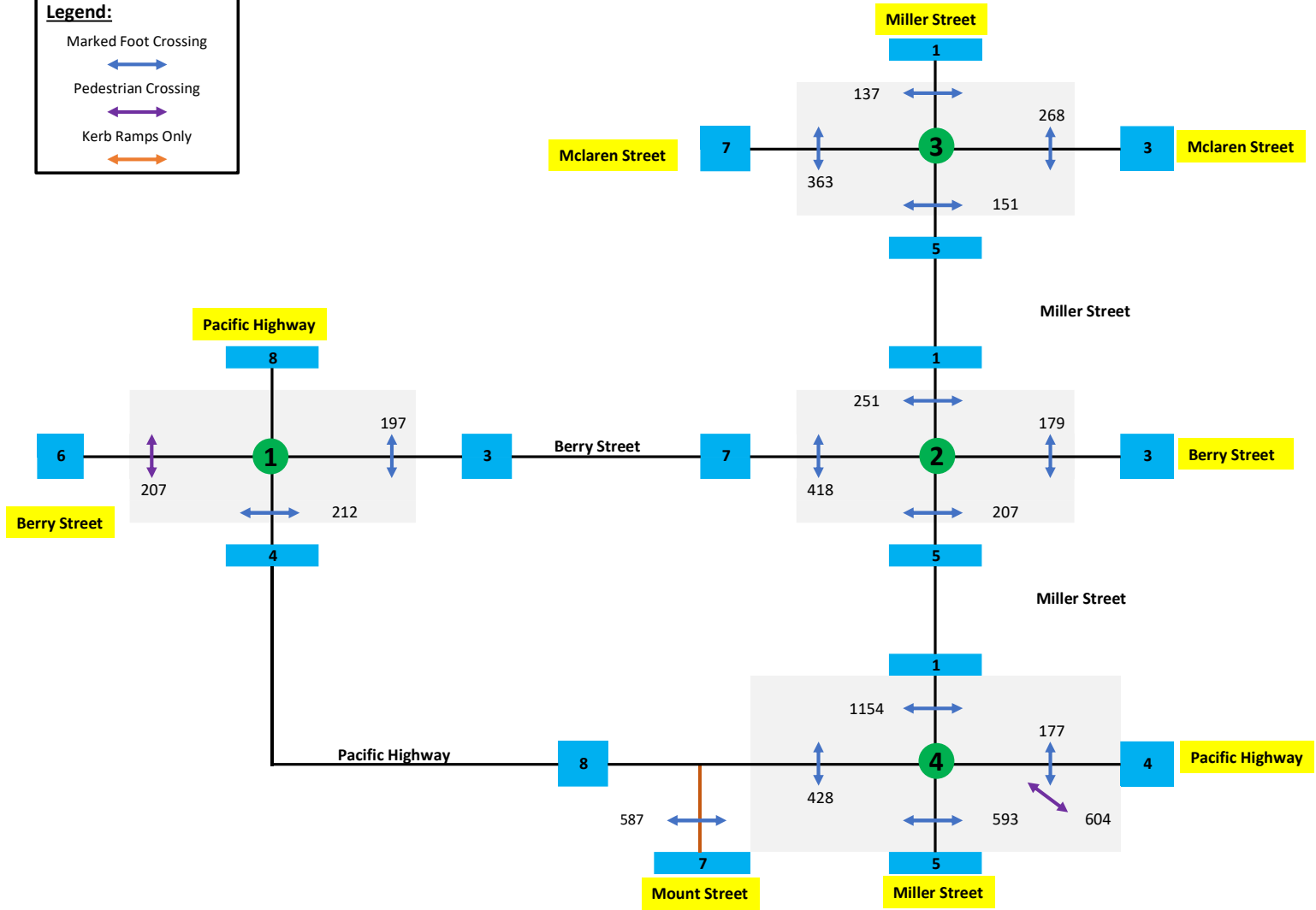

**Block 1**

- Dropoffs:
- Vehicle Type:
- Pedestrians:
- Time Period:
- PM
- BGU-N1 - 5:15 PM (Wed)
- BGU-N2 - 5:30 PM (Thu)
- BGU-N3 - 5:30 PM (Thu)
- BGU-N4 - 5:30 PM (Thu)

**Legend:**

- Marked Foot Crossing
- Pedestrian Crossing
- Keyp Ramps Only

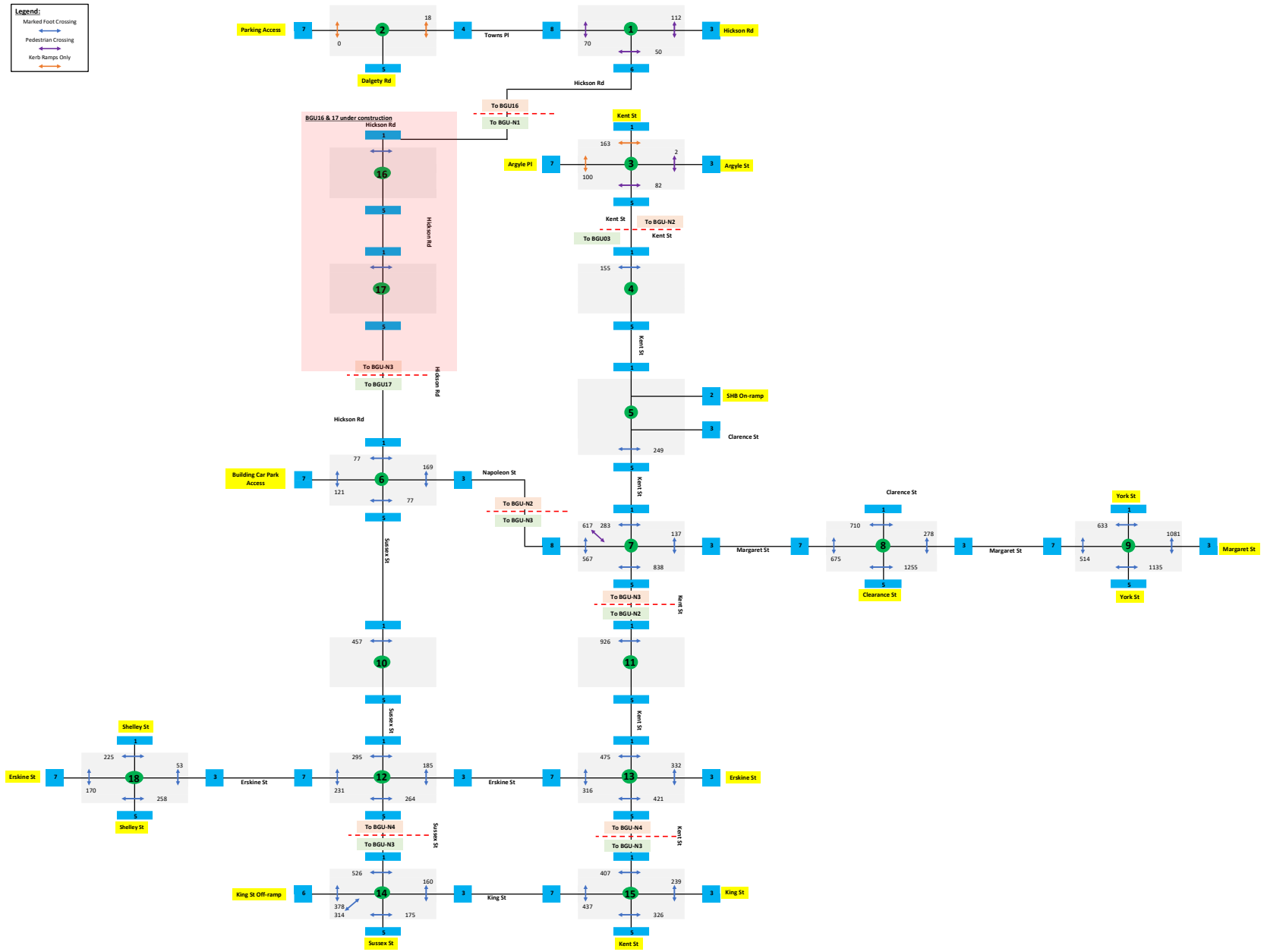

**Block 1**

Dropdowns:  
 Vehicle Type:  
 Pedestrians  
 Time Period:  
 PM  
 MPL-N1 - 5:30 PM (Wed)  
 MPL05 - 6:00 PM (Fri)  
 MPL06 - 5:15 PM (Wed)

**Legend:**

- Marked Foot Crossing
- Pedestrian Crossing
- Kerb Ramps Only

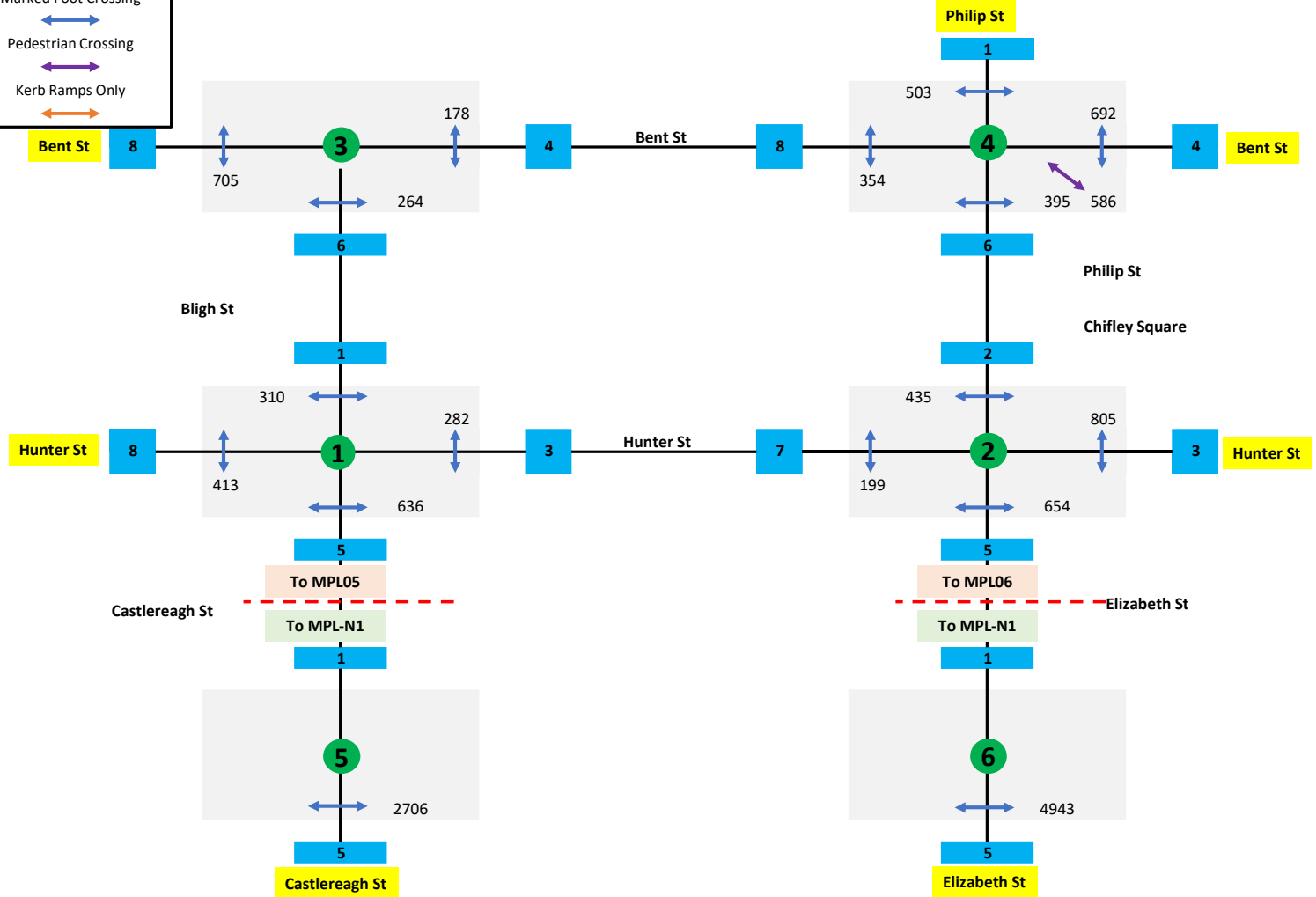



**Block 1**

Dropdowns:  
Vehicle Type:  
Pedestrians  
Time Period:  
PM  
PIT-N1 - 4:45 PM (Thu)

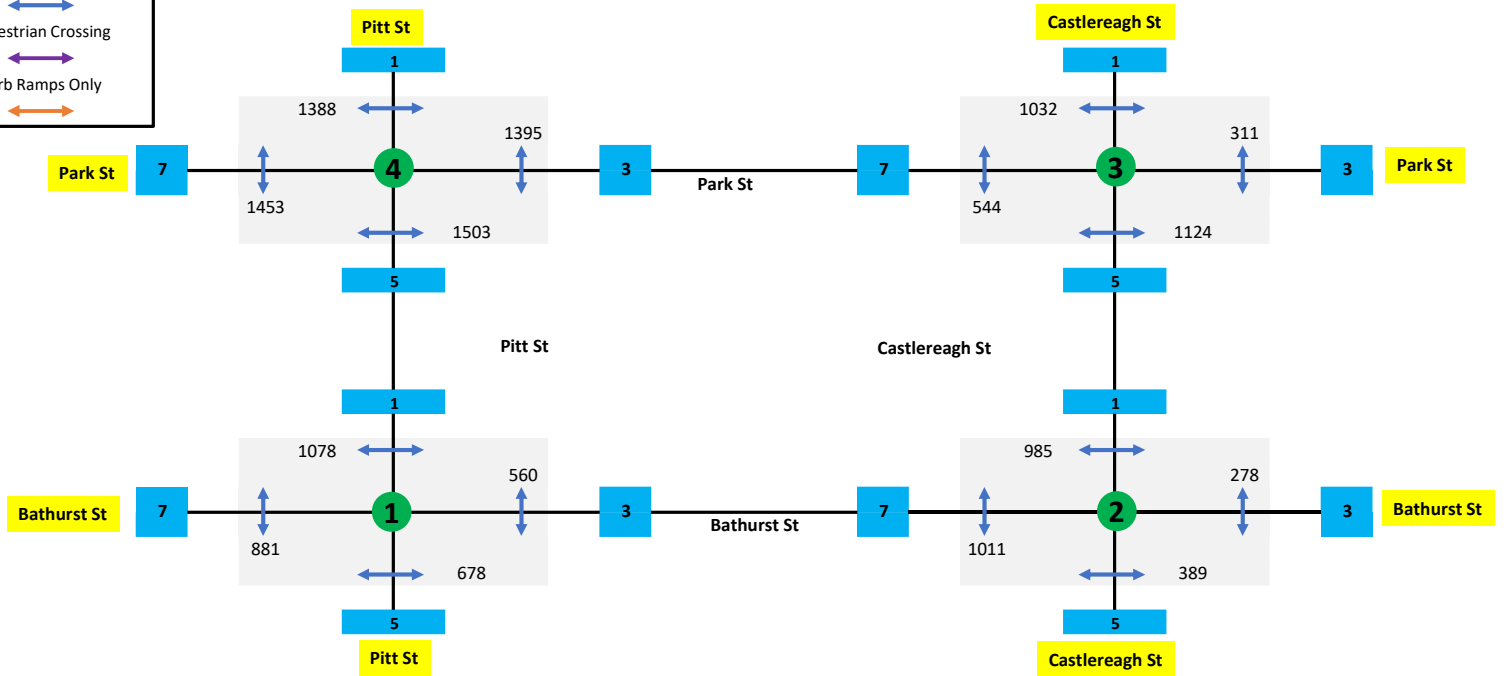
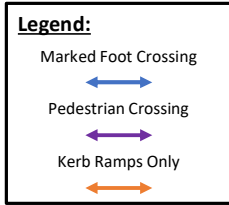

**Block 1**

Dropdowns:

Vehicle Type:

Pedestrians

Time Period:

PM

CEN-N1 - 5:15 PM (Wed)

CEN-N2 - 5:30 PM (Thu)

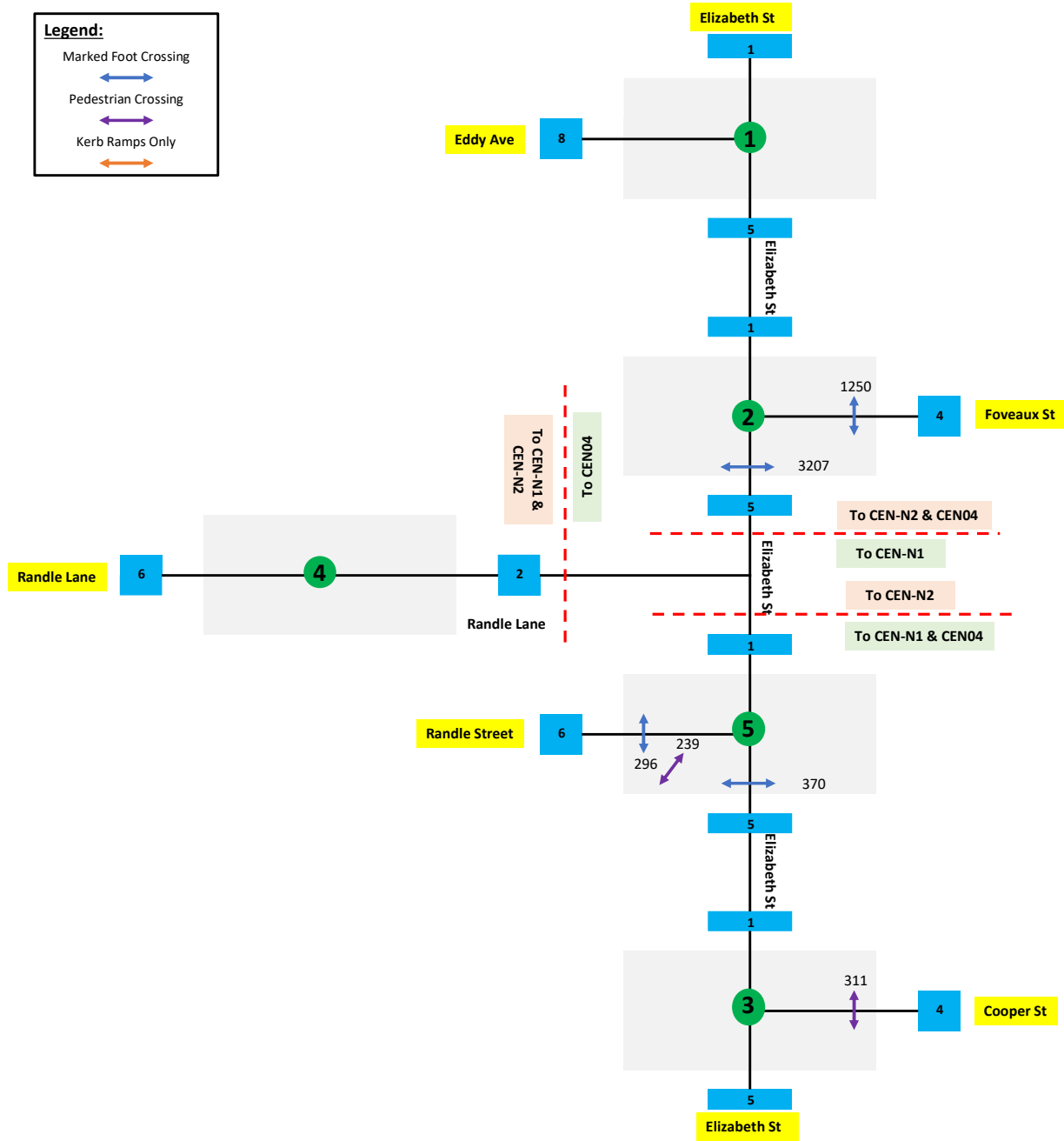
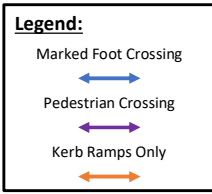

Block 1

Dropdowns:  
Vehicle Type:  
Pedestrians  
Time Period:  
PM  
WLO-N1 - 5:00 PM (Wed)

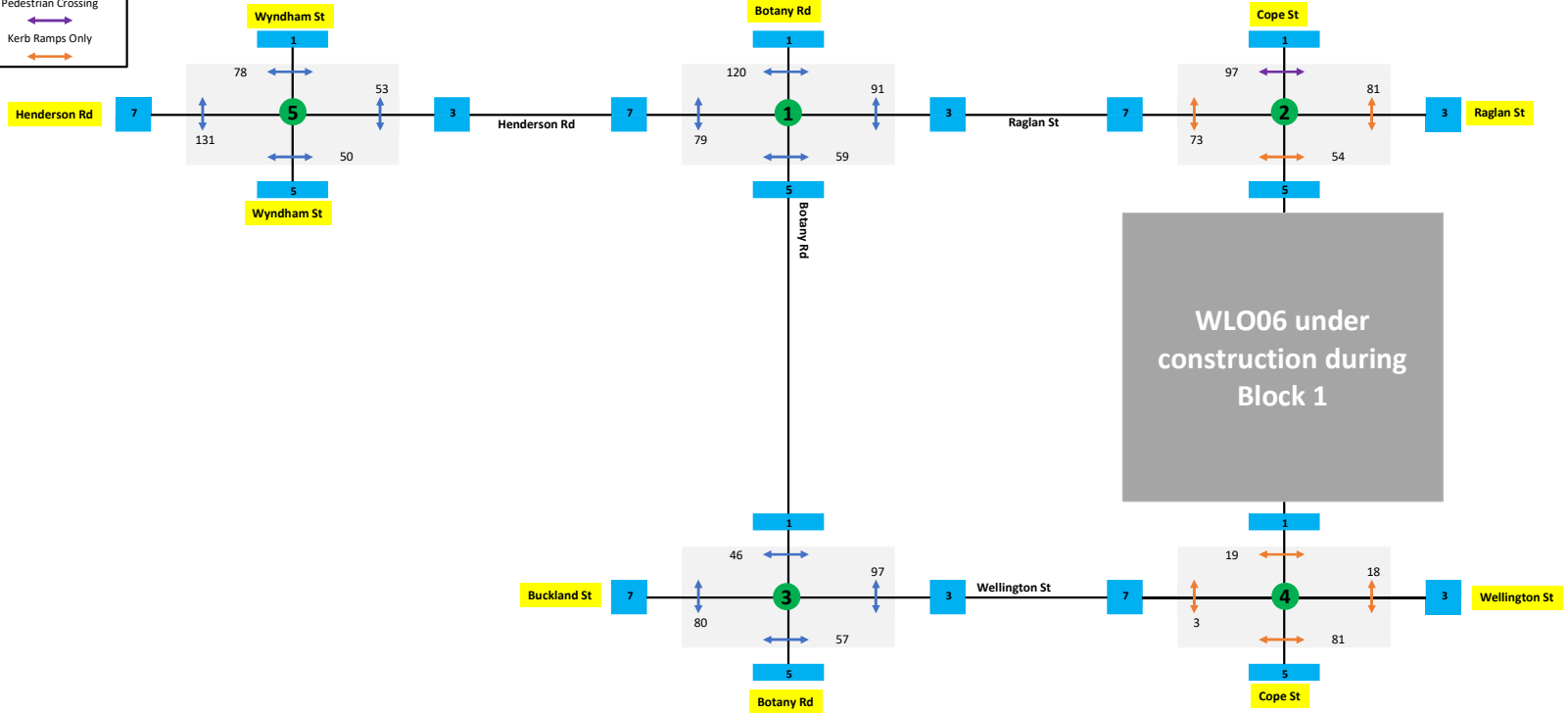
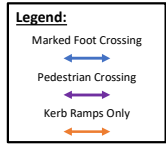

**Block 1**

Dropdowns:

Vehicle Type:

Pedestrians

Time Period:

PM

SYD-N1 - 3:30 PM (Wed)

SYD03 - 3:45 PM (Tue)

SYD04 - 4:15 PM (Tue)

SYD05 - 4:45 PM (Tue)

SYD06 - 3:15 PM (Fri)

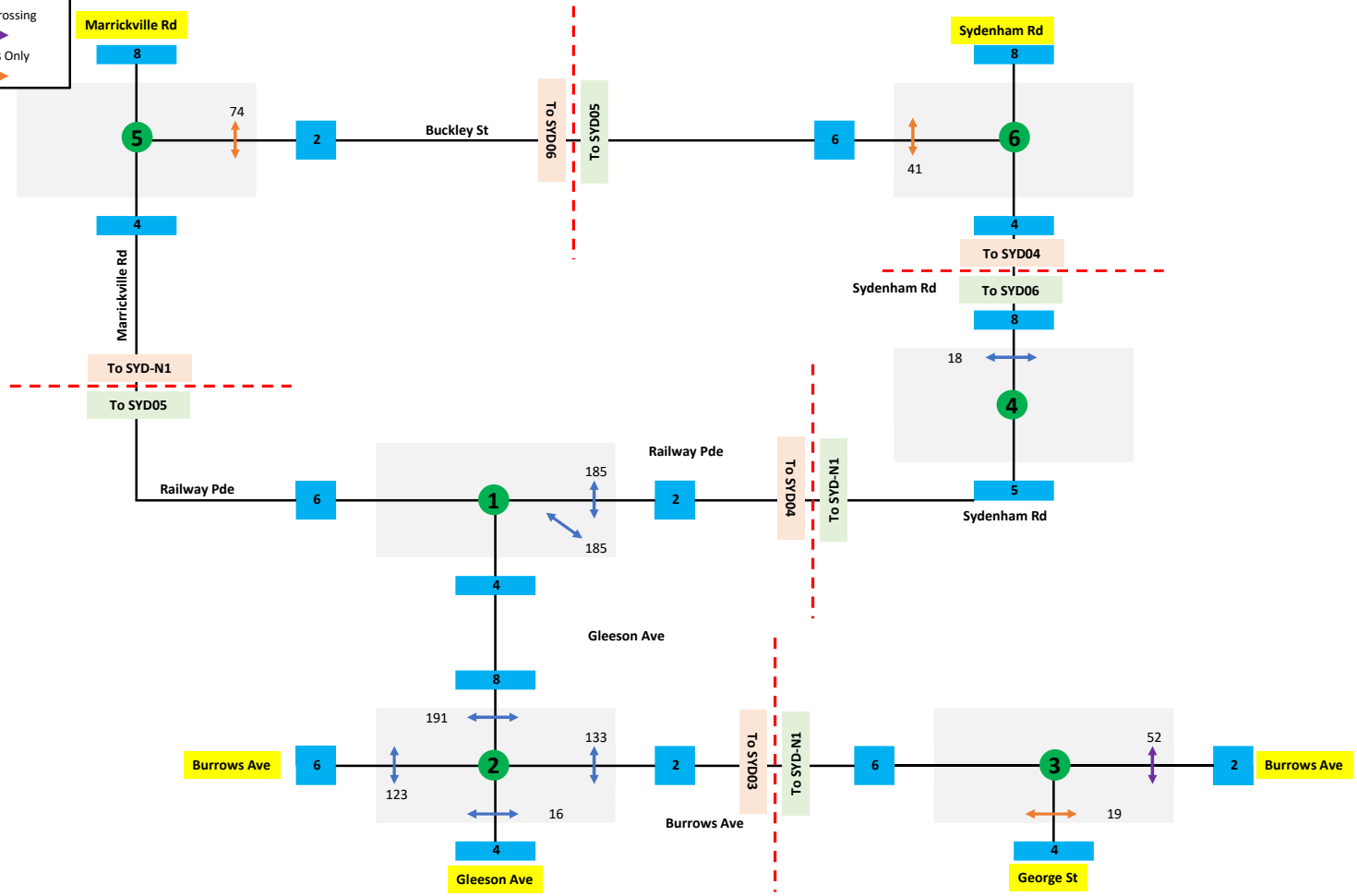
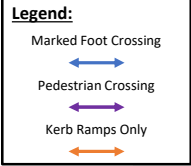

**Block 1**

Dropdowns:

Vehicle Type:

Pedestrians

Time Period:

WEEKEND

CWDD01 - 11:15 AM (Sat)

CWDD02 - 12:30 PM (Sat)

**Legend:**

Marked Foot Crossing



Pedestrian Crossing



Kerb Ramps Only

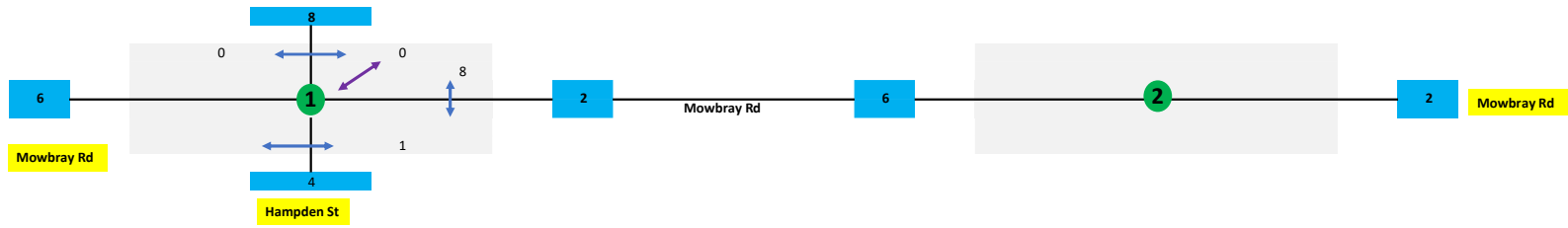

Block 1  
 Dropdown:  
 Vehicle Type:  
 Pedestrians  
 Time Period:  
 WEEKEND  
 CST-N1 - 11:30 AM (Sat)  
 CST07 - 11:45 AM (Sat)  
 CST08 - 11:30 AM (Sat)

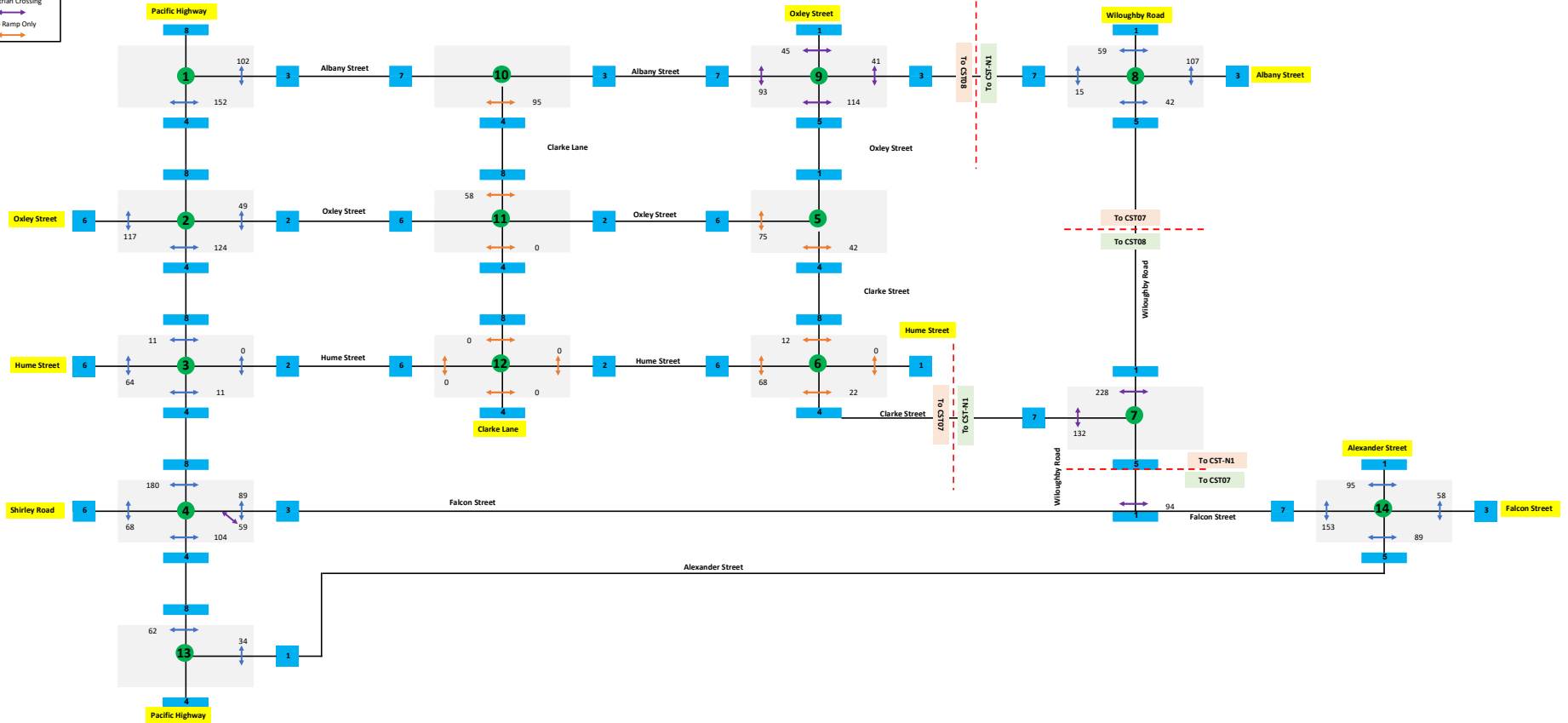



**Block 1**

Dropdowns:

Vehicle Type:

Pedestrians

Time Period:

WEEKEND

VIC-N1 - 11:30 AM (Sat)

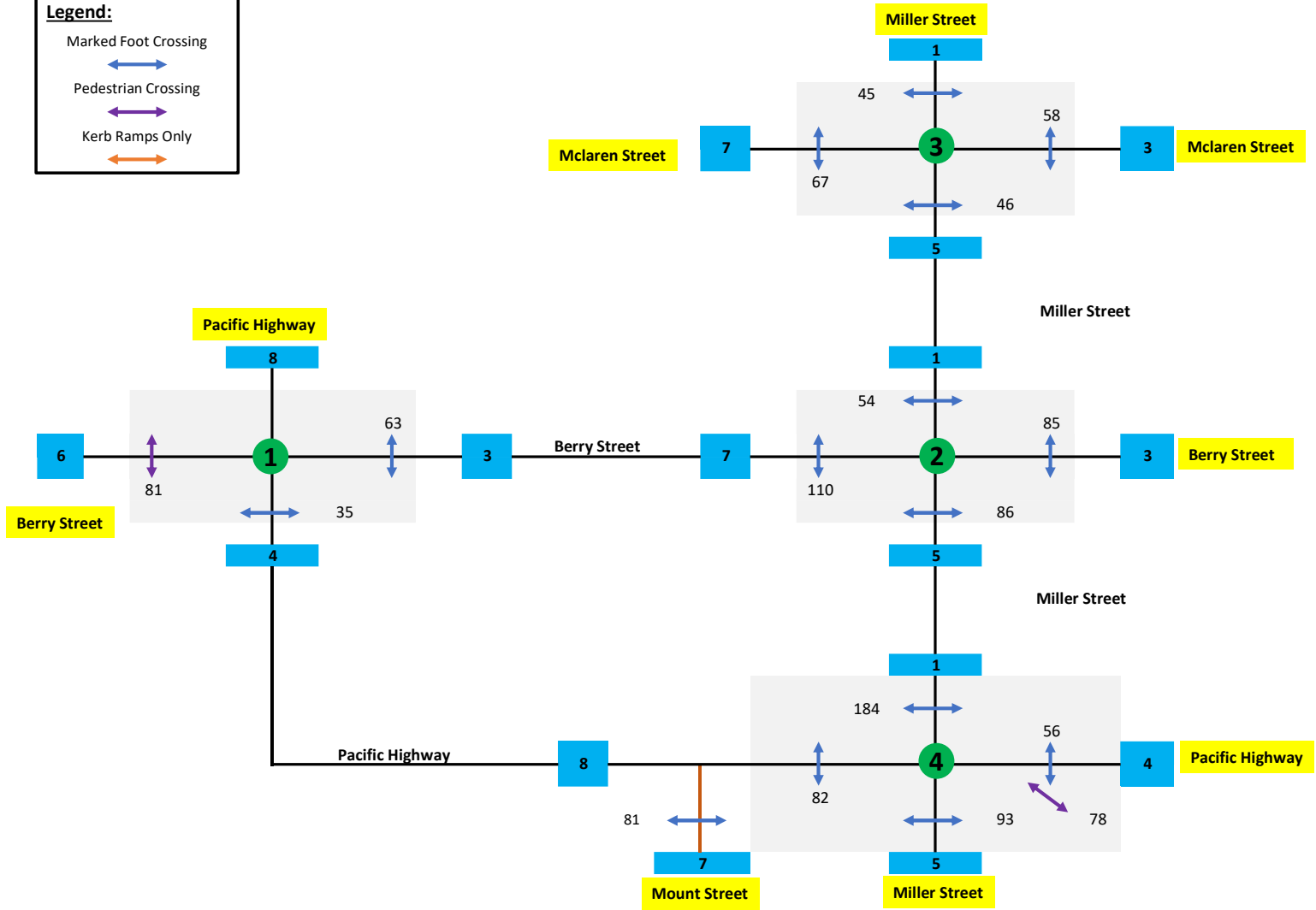
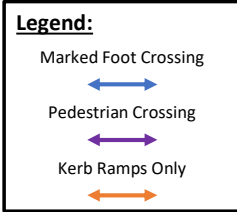

**Block 1**

- Dropouts:
- Vehicle Type:
- Pedestrians:
- Time Period:
- WEEKEND
- BGU-N1 - 1:15 PM (Sat)
- BGU-N2 - 12:15 PM (Sat)
- BGU-N3 - 12:15 PM (Sat)
- BGU-N4 - 12:15 PM (Sat)

**Legend:**

- Marked Foot Crossing
- Pedestrian Crossing
- Keyp Ramps Only

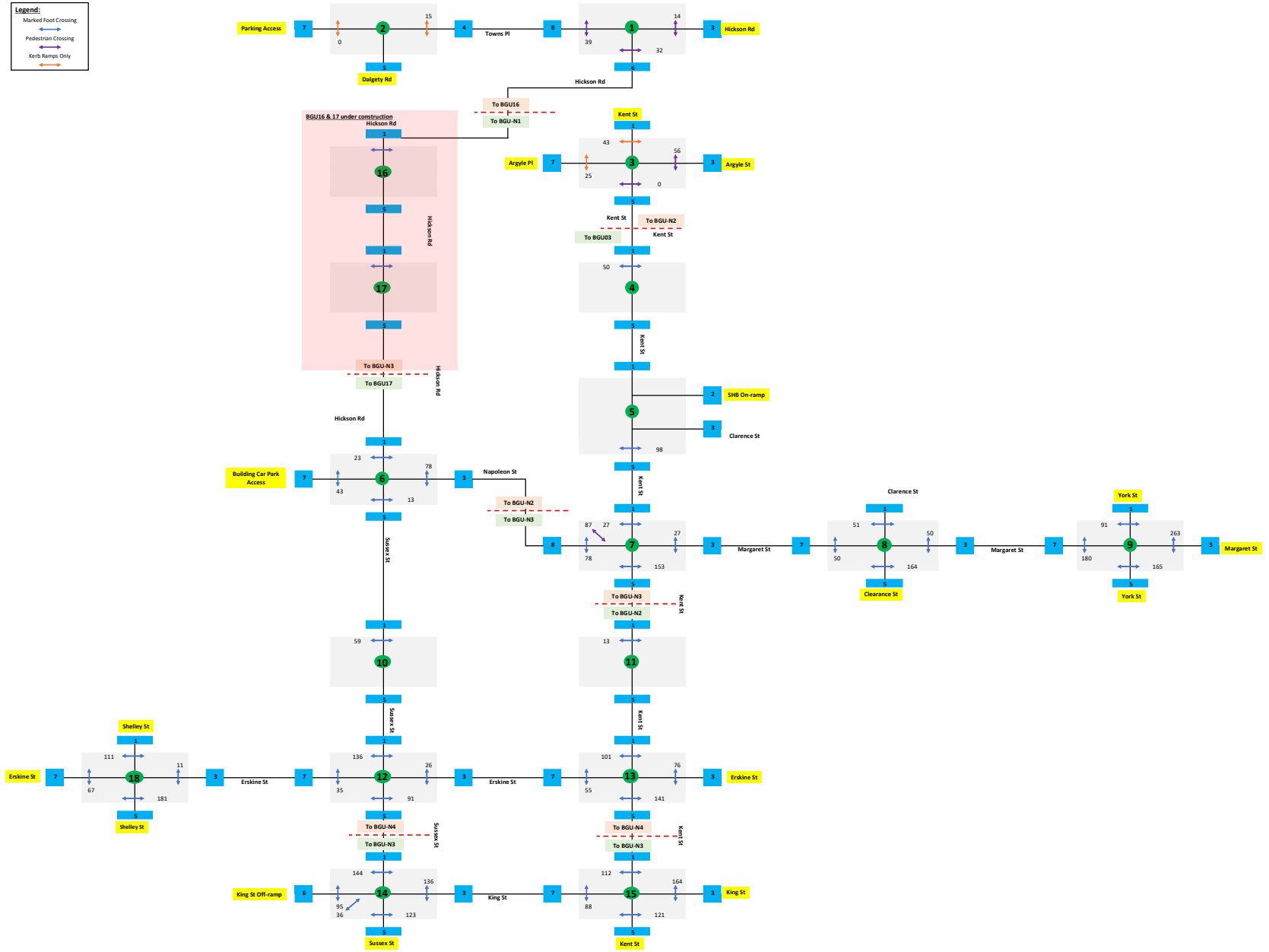

**Block 1**

Dropdowns:

Vehicle Type:

Pedestrians

Time Period:

WEEKEND

MPL-N1 - 12:15 PM (Sat)

MPL05 - 1:30 PM (Sat)

MPL06 - 12:15 PM (Sat)

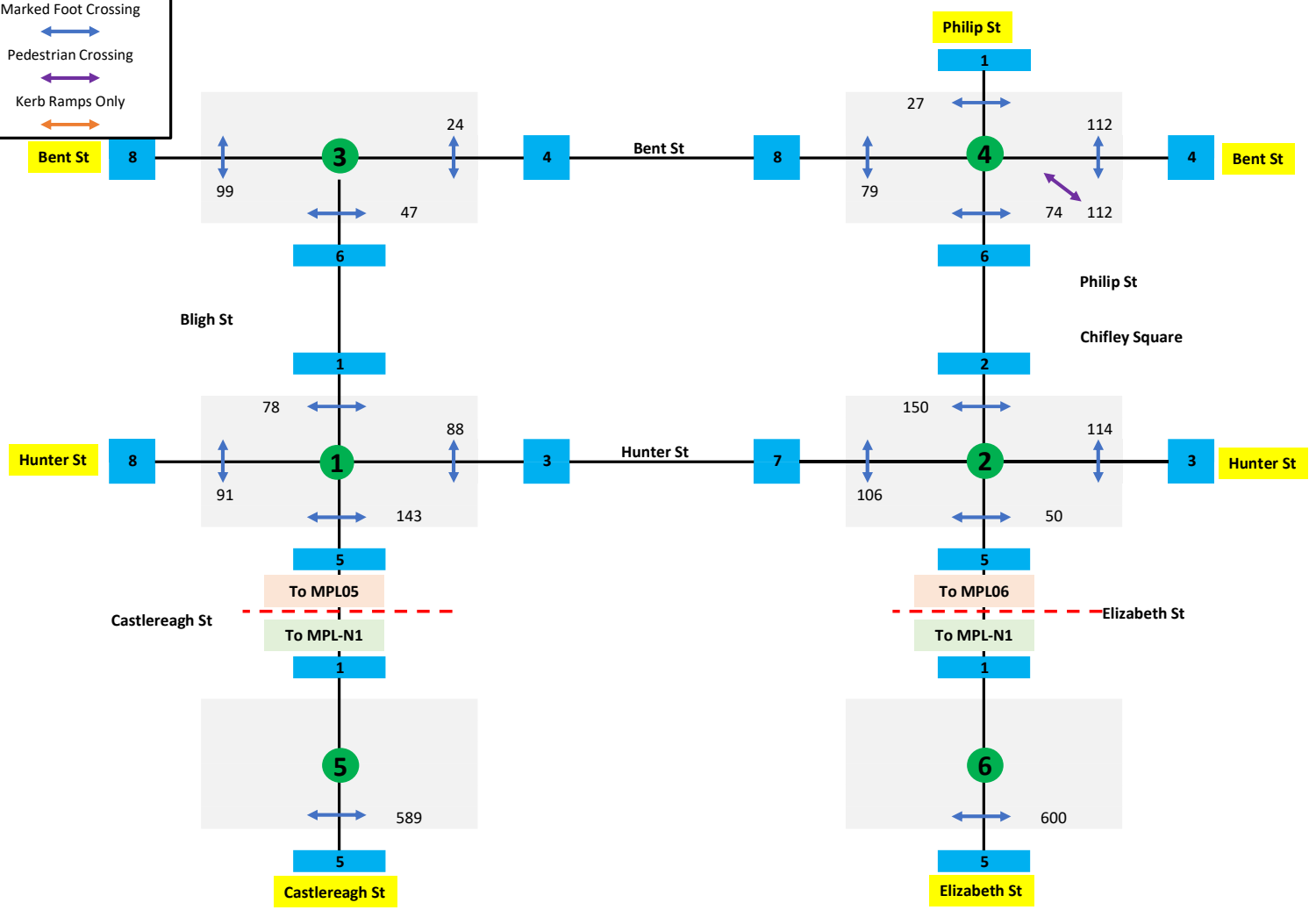
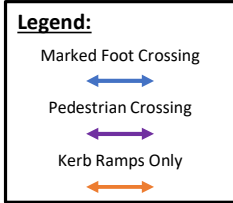

**Block 1**

Dropdowns:  
Vehicle Type:  
Pedestrians  
Time Period:  
**WEEKEND**  
PIT-N1 - 12:15 PM (Sat)

**Legend:**

- Marked Foot Crossing
- Pedestrian Crossing
- Kerb Ramps Only

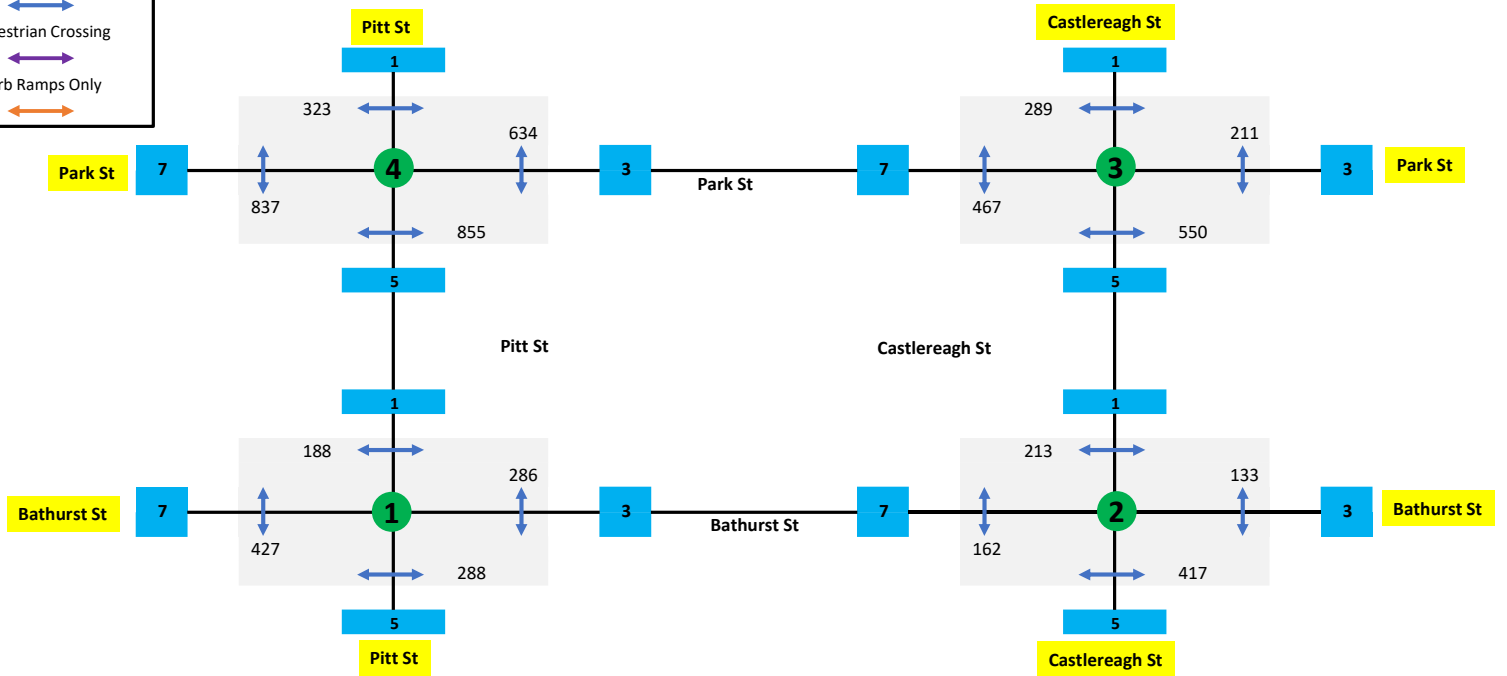

**Block 1**

Dropdowns:

Vehicle Type:

Pedestrians

Time Period:

WEEKEND

CEN-N1 - 1:45 PM (Sat)

CEN-N2 - 12:00 PM (Sat)

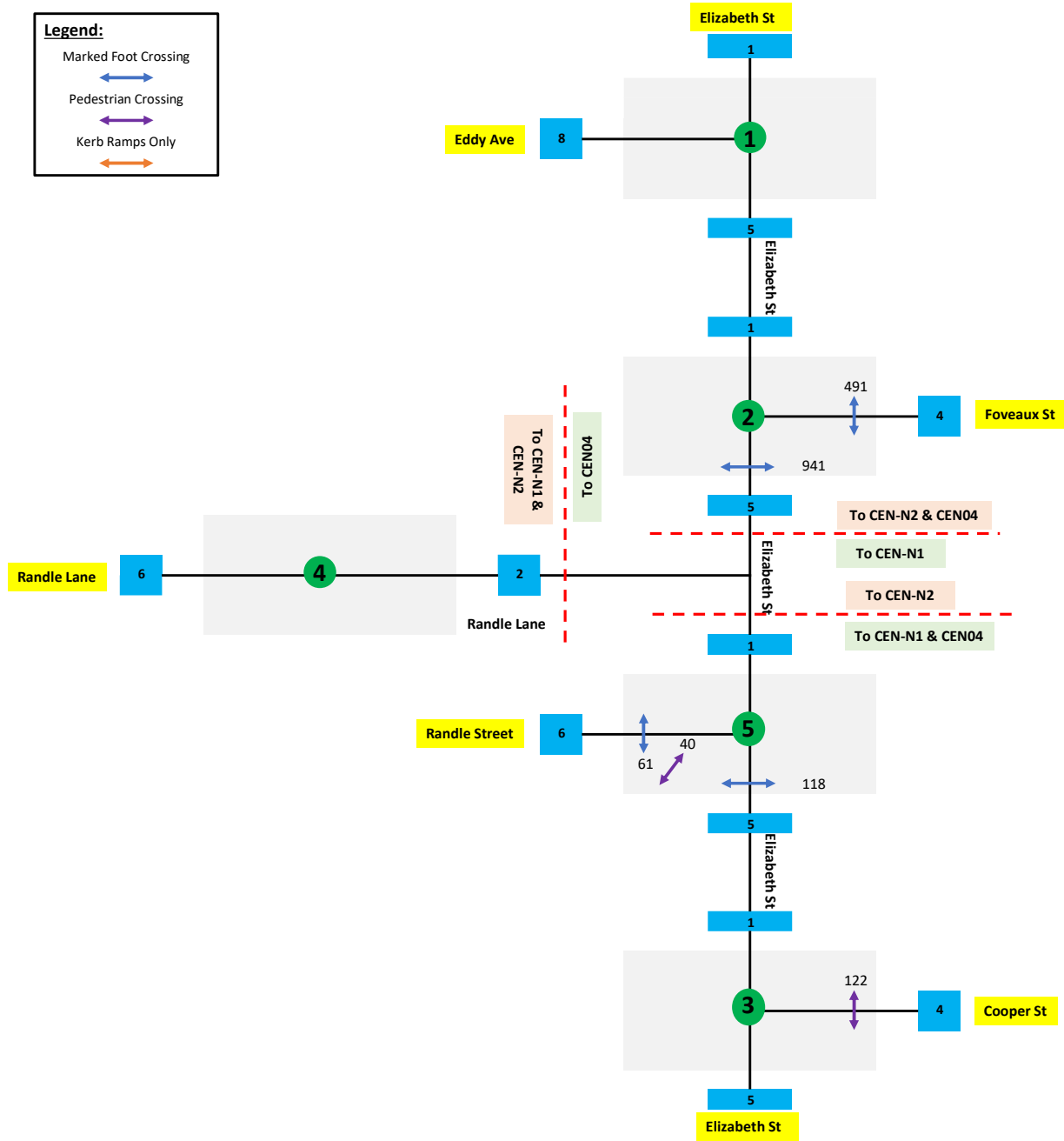
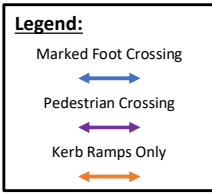

Block 1

Dropdowns:  
Vehicle Type:  
Pedestrians  
Time Period:  
WEEKEND  
WLO-N1 - 12:15 PM (Sat)

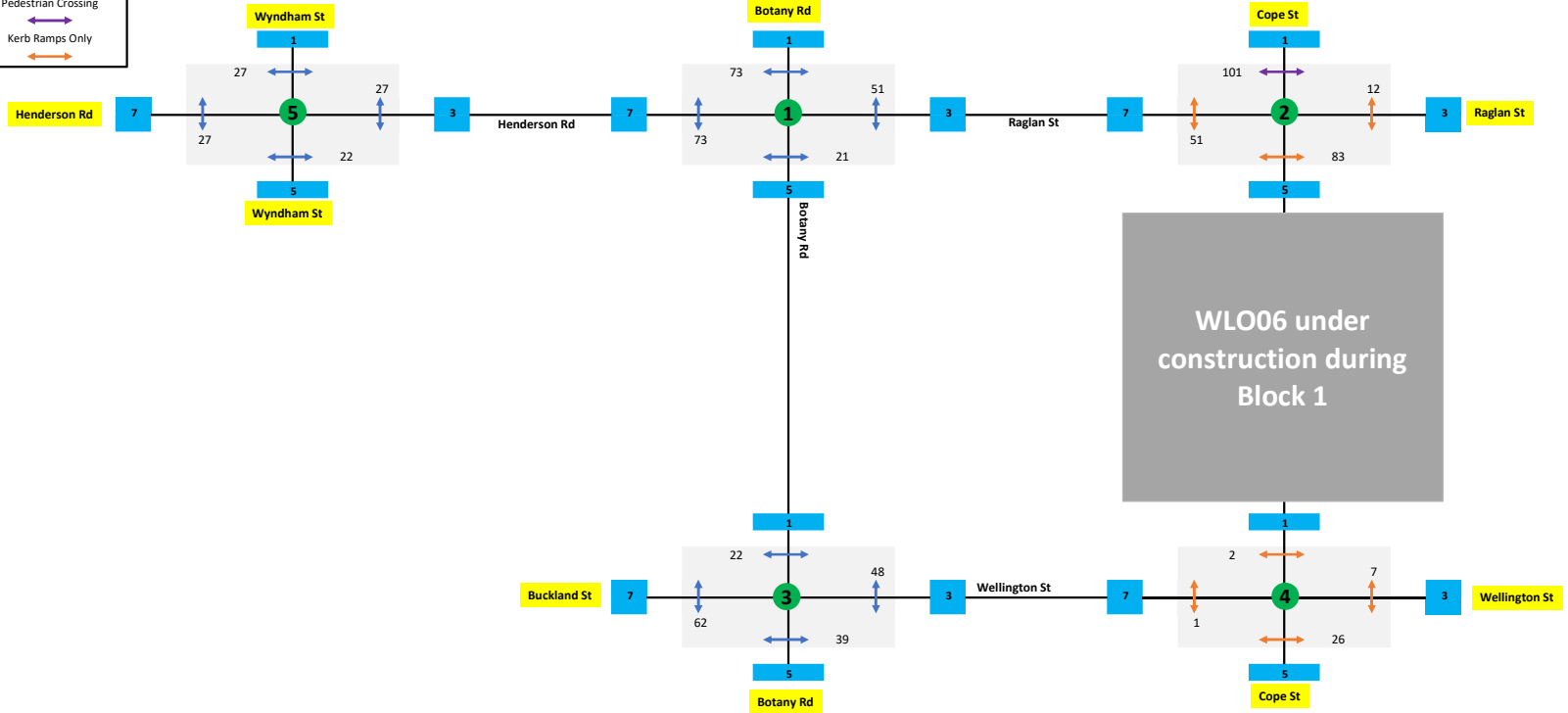
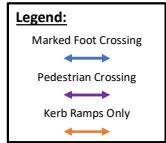



**Block 1**

Dropdowns:

Vehicle Type:

Pedestrians

Time Period:

WEEKEND

SYD-N1 - 1:00 PM (Sun)

SYD03 - 1:00 PM (Sat)

SYD04 - 1:45 PM (Sat)

SYD05 - 1:45 PM (Sat)

SYD06 - 10:30 AM (Sat)

**Legend:**

- Marked Foot Crossing
- Pedestrian Crossing
- Kerb Ramps Only

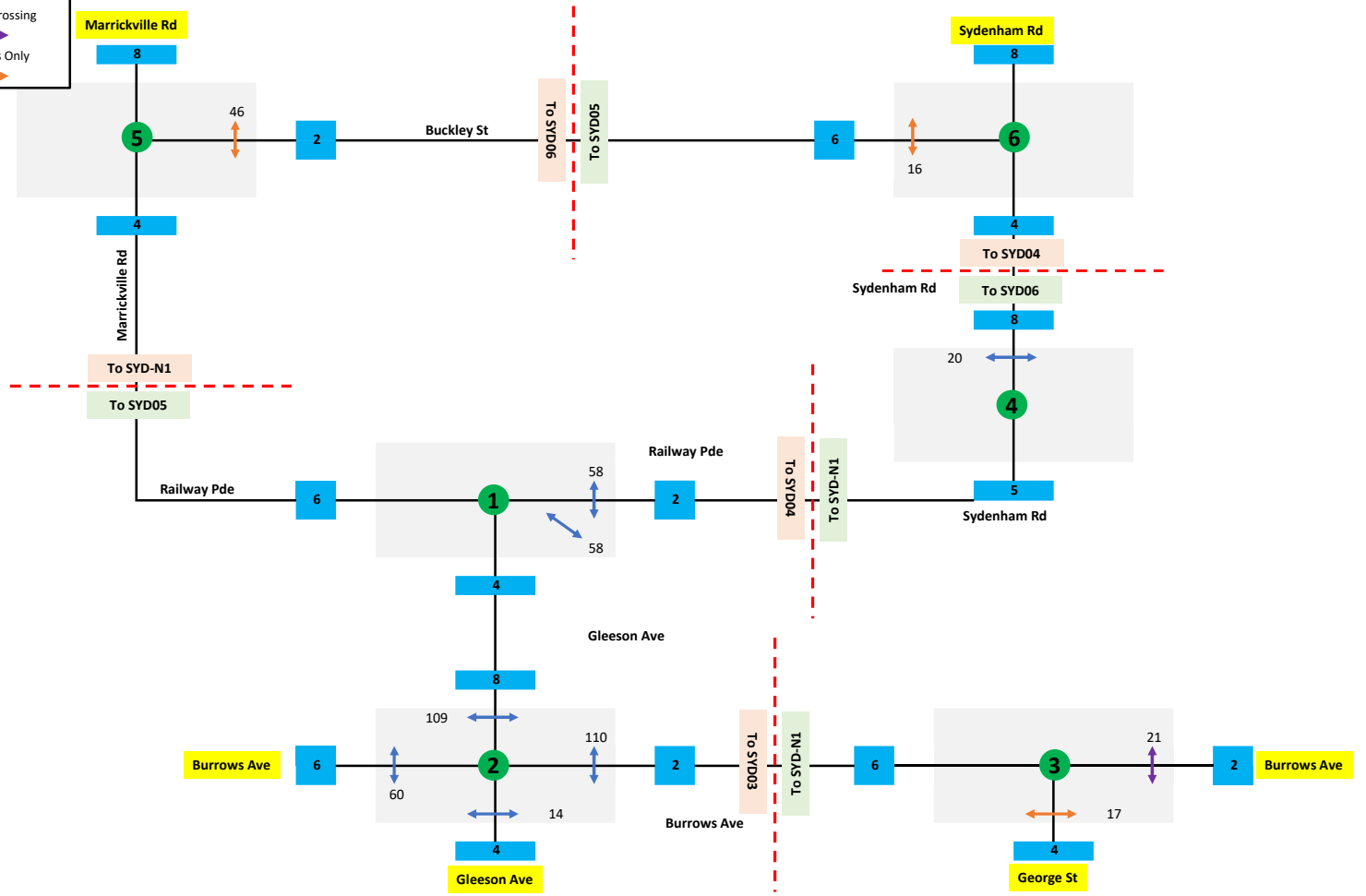

# Appendix D

## Traffic Monitoring – Station Overview

Appendix D Traffic Monitoring – Station Overview

> **Chatswood Station** **2** **Intersections**

Map

ID ● CWD01 ● CWD02

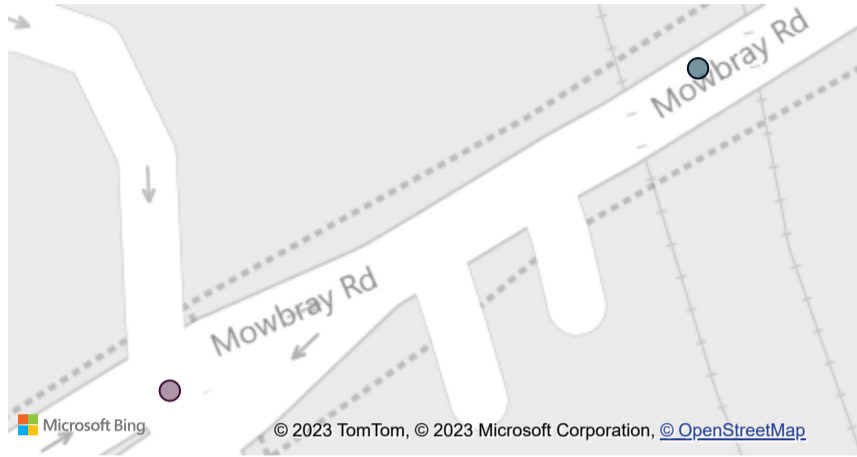

Total Mode Split

Mode ● Buses ● Cyclists ● Heavy Vehicles ● Light Vehicles

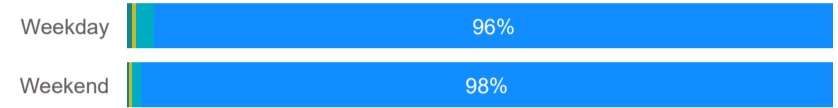

% Mode Split

| Day     | Buses | Cyclists | Heavy Vehicles | Light Vehicles |
|---------|-------|----------|----------------|----------------|
| Weekday | 0.7%  | 0.6%     | 2.6%           | 96.1%          |
| Weekend | 0.2%  | 0.5%     | 1.2%           | 98.1%          |

Average daily vehicles and cyclists profile for a weekday and weekend

Day ● Weekday ● Weekend

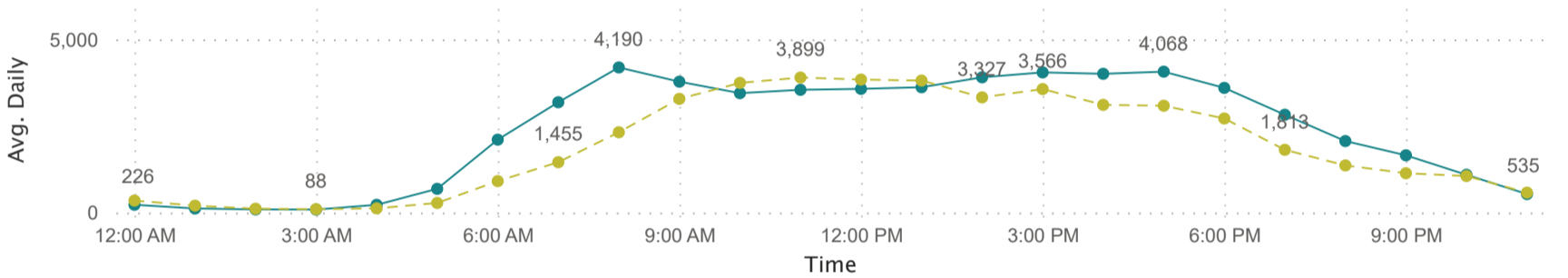

Cyclists volumes

Day ● Monday ● Tuesday ● Wednesday ● Thursday ● Friday ● Saturday ● Sunday

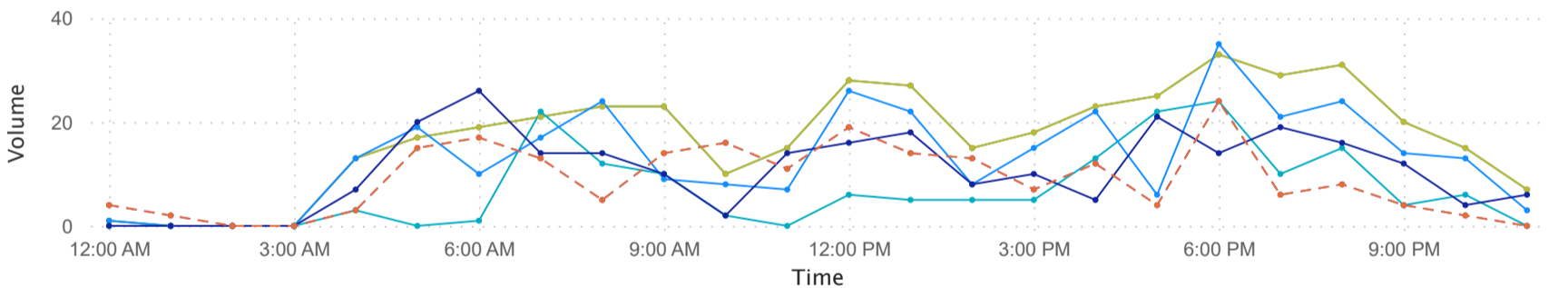

Pedestrian volumes

Day ● Monday ● Tuesday ● Wednesday ● Thursday ● Friday ● Saturday ● Sunday

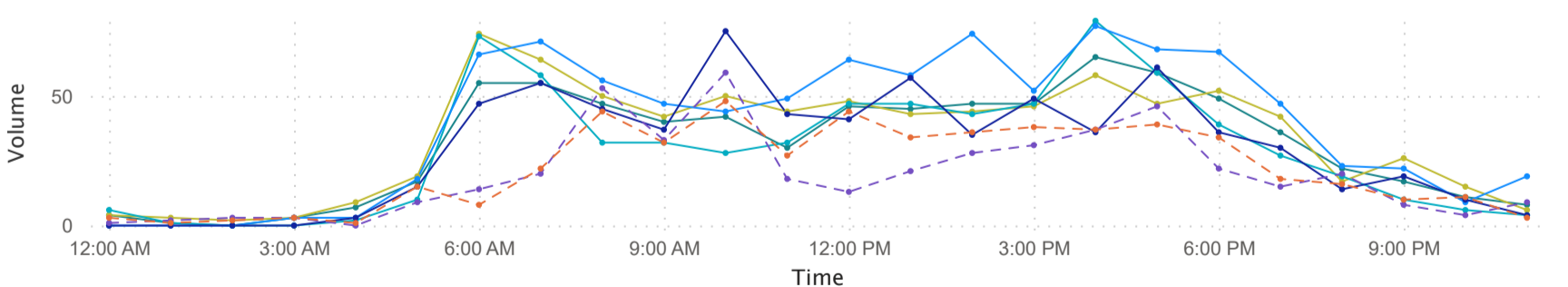

Vehicle volumes

Day ● Monday ● Tuesday ● Wednesday ● Thursday ● Friday ● Saturday ● Sunday

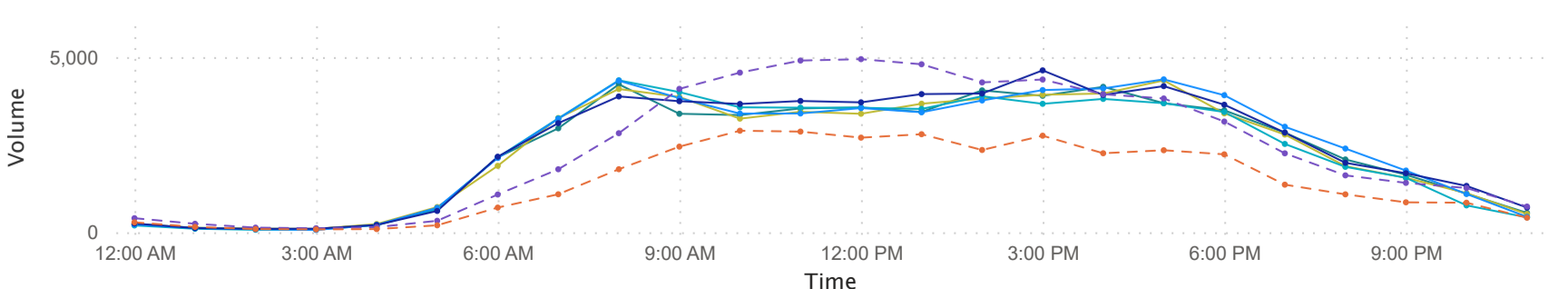
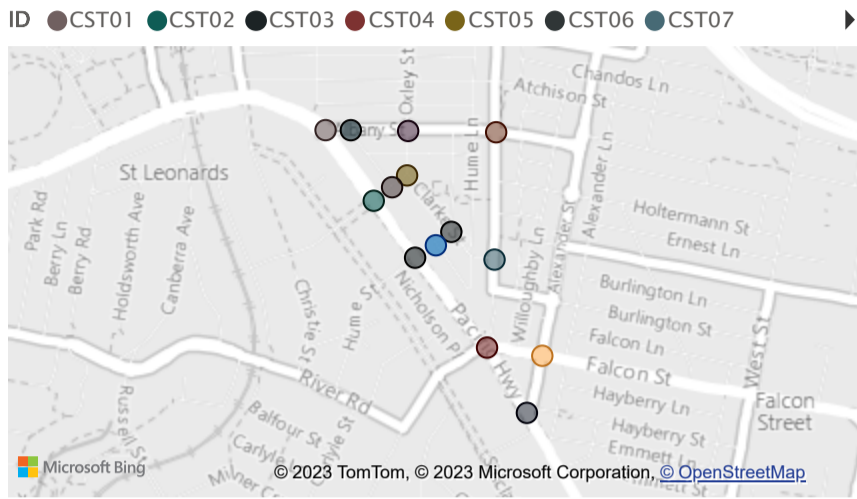

FIGURE 5-XX

> **Crows Nest Station** **14** **Intersections**

Map



Total Mode Split

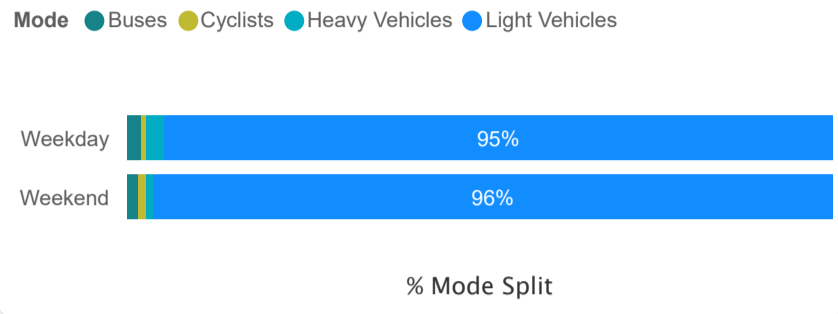

| Day     | Buses | Cyclists | Heavy Vehicles | Light Vehicles |
|---------|-------|----------|----------------|----------------|
| Weekday | 2.0%  | 0.7%     | 2.5%           | 94.8%          |
| Weekend | 1.5%  | 1.2%     | 1.0%           | 96.4%          |

Average daily vehicles and cyclists profile for a weekday and weekend

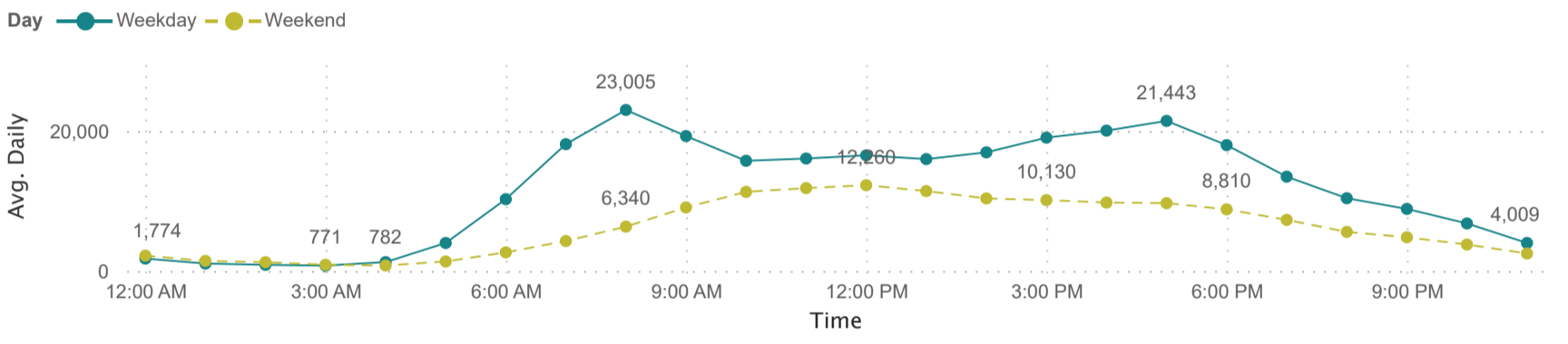

Cyclists volumes

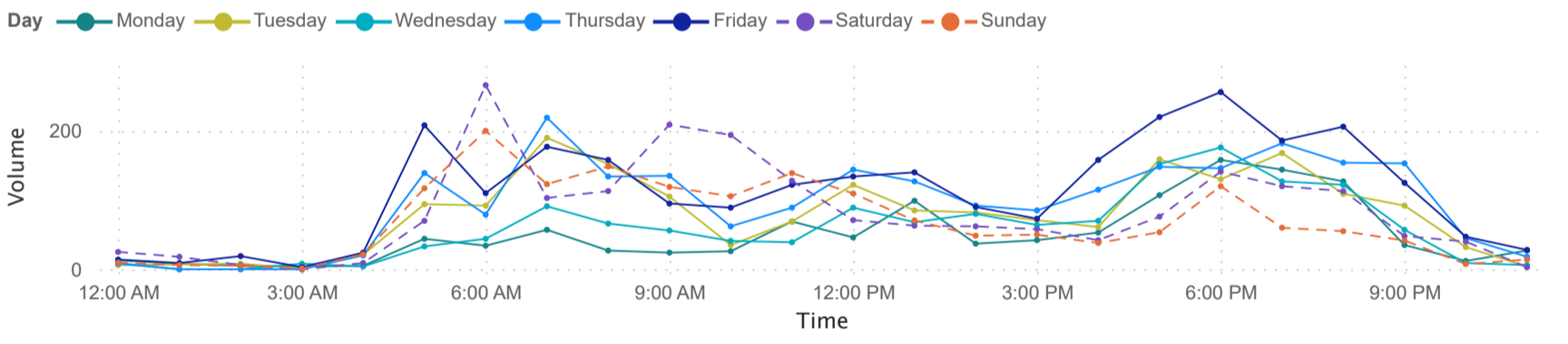

Pedestrian volumes

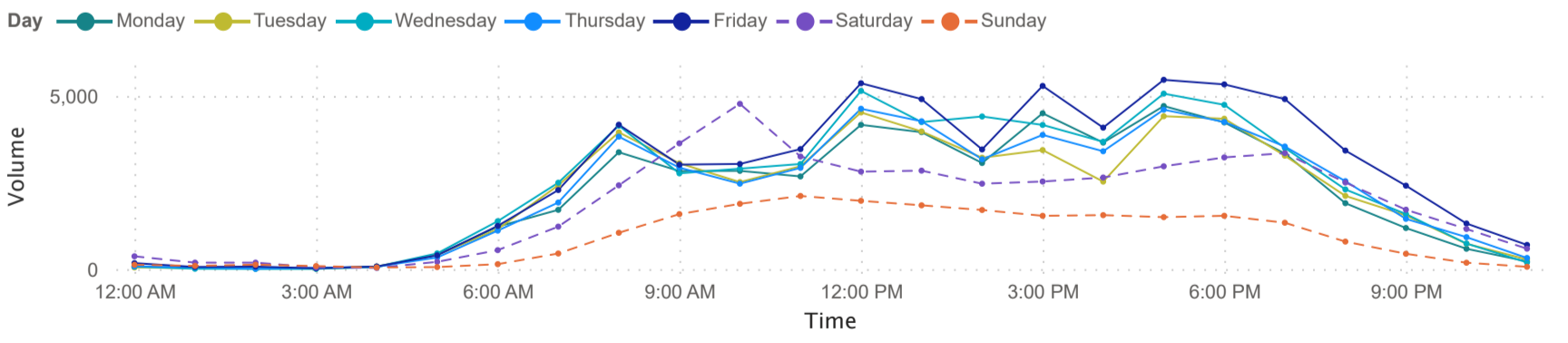

Vehicle volumes

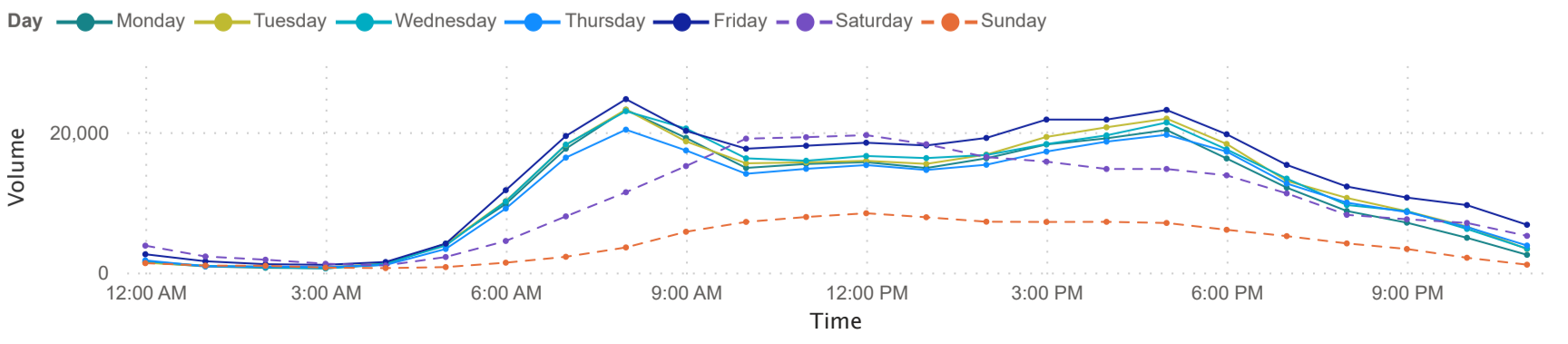
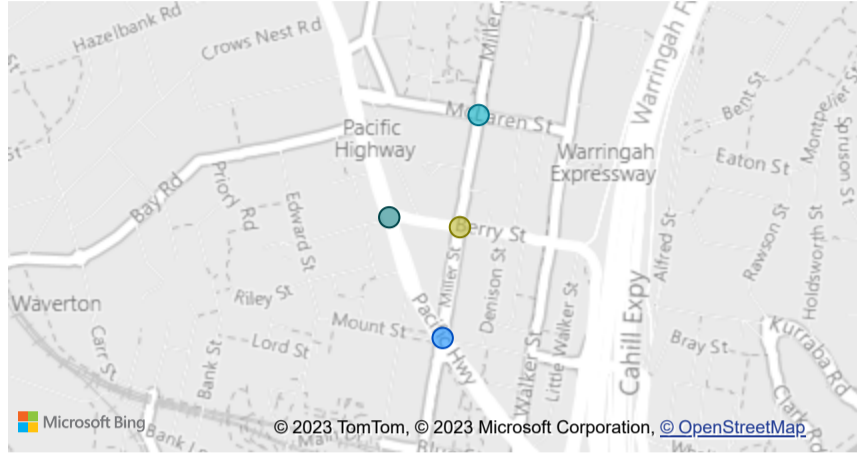

FIGURE 5-XX

> **Victoria Cross Station** **4** **Intersections**

Map

ID ● VIC01 ● VIC02 ● VIC03 ● VIC04



Total Mode Split

Mode ● Buses ● Cyclists ● Heavy Vehicles ● Light Vehicles

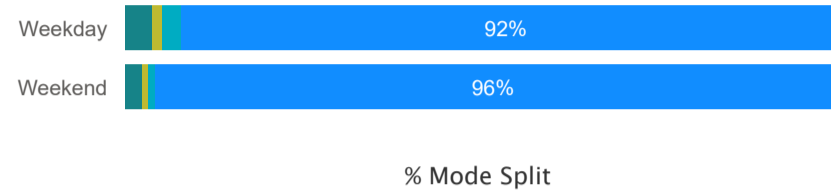

| Day     | Buses | Cyclists | Heavy Vehicles | Light Vehicles |
|---------|-------|----------|----------------|----------------|
| Weekday | 3.7%  | 1.6%     | 2.6%           | 92.1%          |
| Weekend | 2.3%  | 1.0%     | 1.0%           | 95.7%          |

Average daily vehicles and cyclists profile for a weekday and weekend

Day ● Weekday ● Weekend

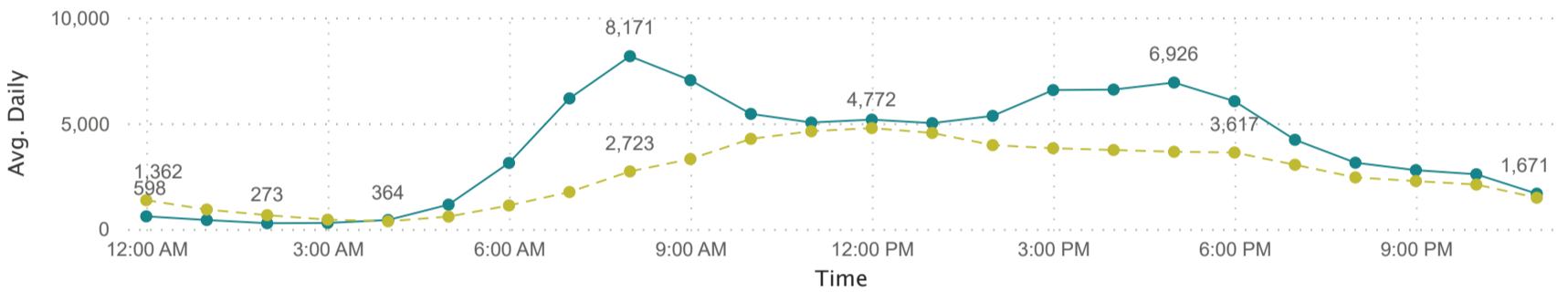

Cyclists volumes

Day ● Monday ● Tuesday ● Wednesday ● Thursday ● Friday ● Saturday ● Sunday

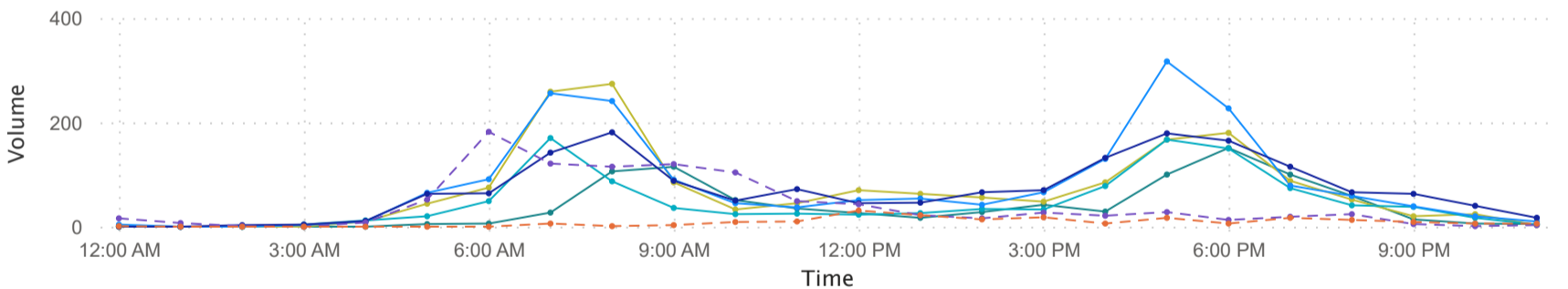

Pedestrian volumes

Day ● Monday ● Tuesday ● Wednesday ● Thursday ● Friday ● Saturday ● Sunday

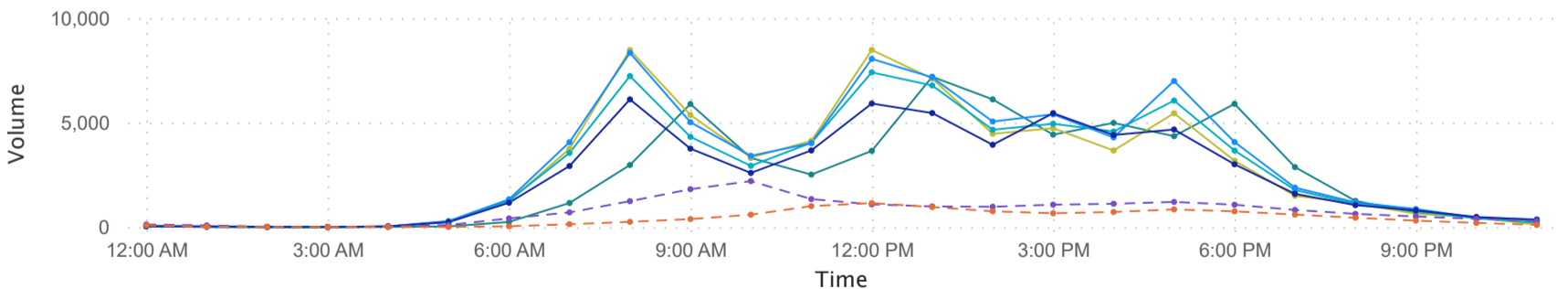

Vehicle volumes

Day ● Monday ● Tuesday ● Wednesday ● Thursday ● Friday ● Saturday ● Sunday

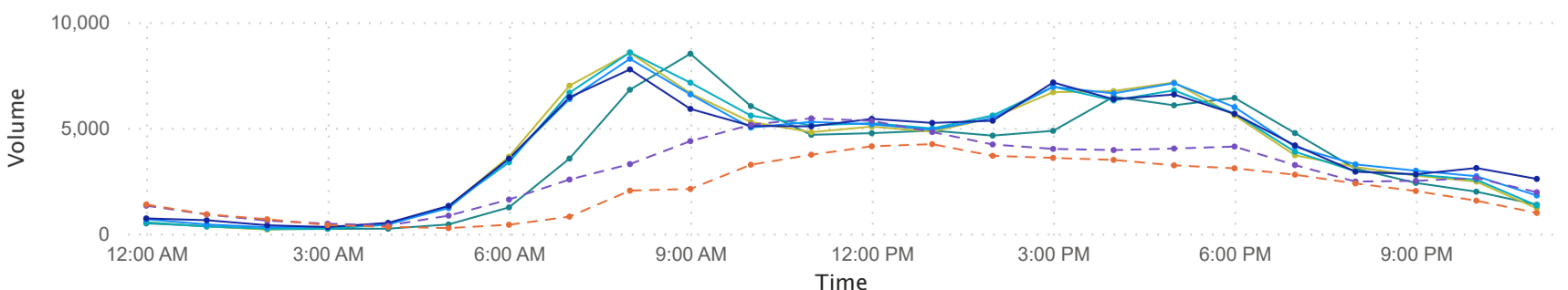
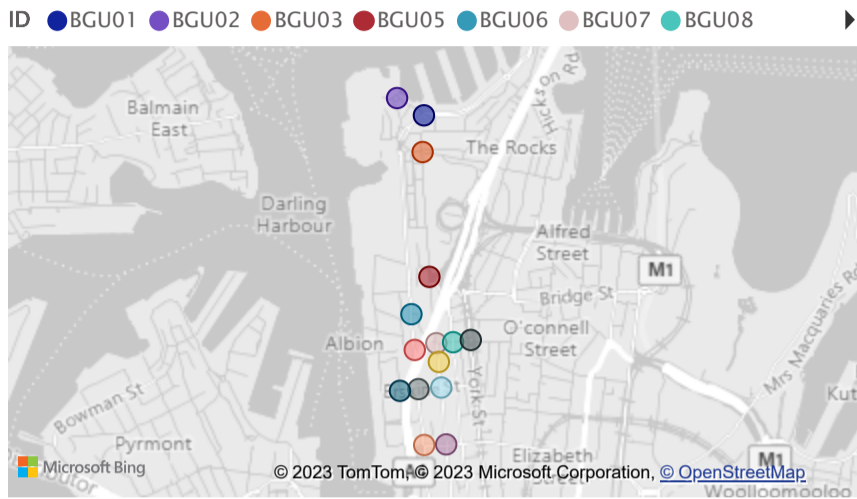

FIGURE 5-XX



> **Barangaroo Station** **15** **Intersections**

Map



Total Mode Split

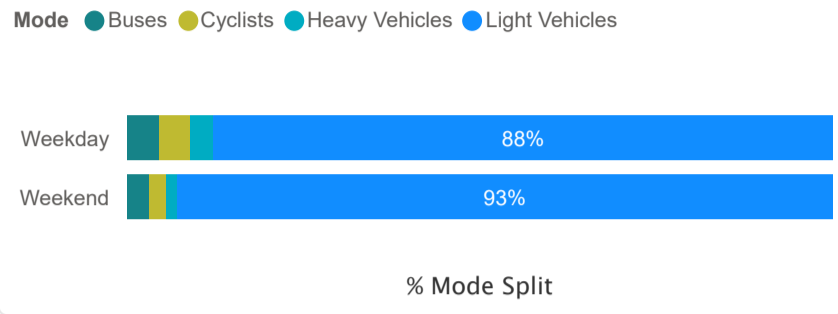

| Day     | Buses | Cyclists | Heavy Vehicles | Light Vehicles |
|---------|-------|----------|----------------|----------------|
| Weekday | 4.5%  | 4.3%     | 3.4%           | 87.8%          |
| Weekend | 3.0%  | 2.5%     | 1.5%           | 93.0%          |

Average daily vehicles and cyclists profile for a weekday and weekend

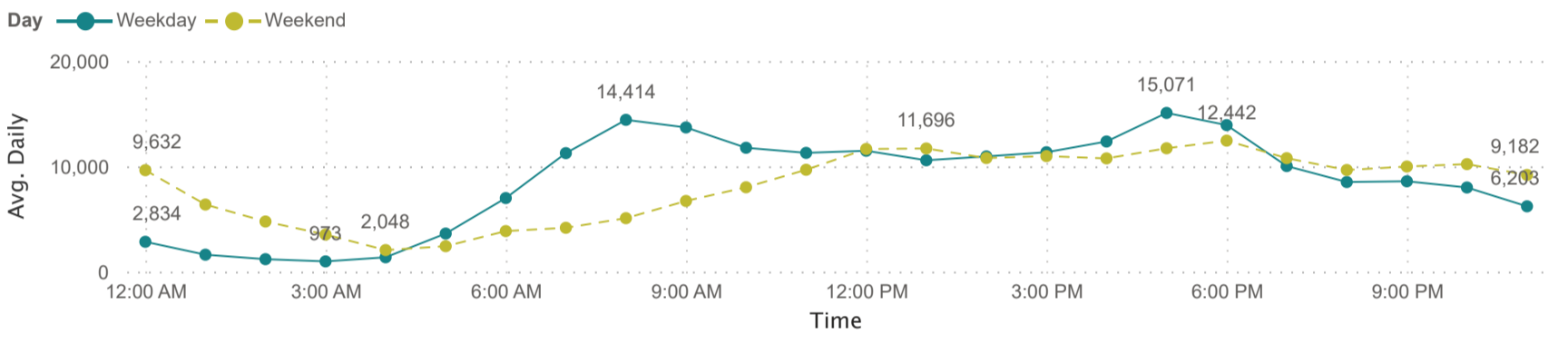

Cyclists volumes

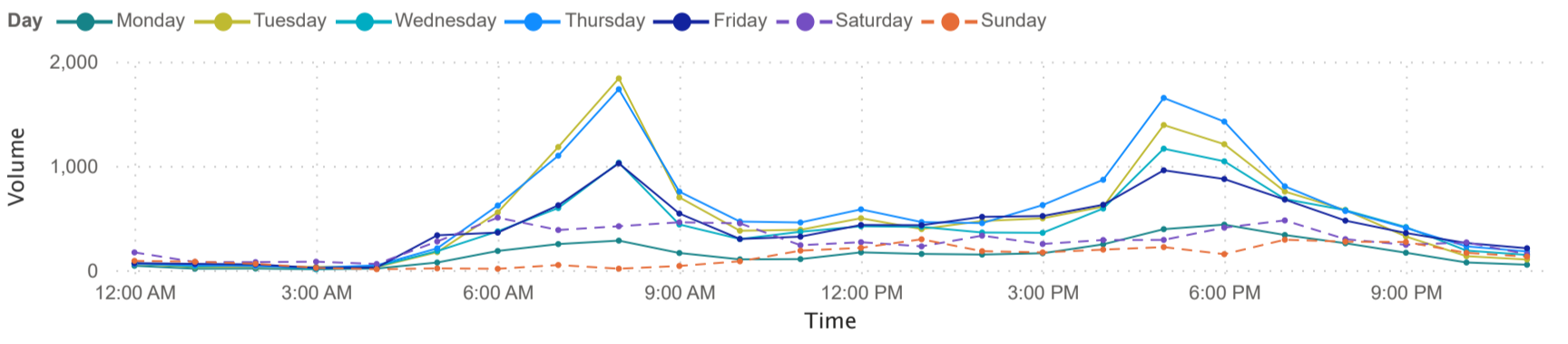

Pedestrian volumes

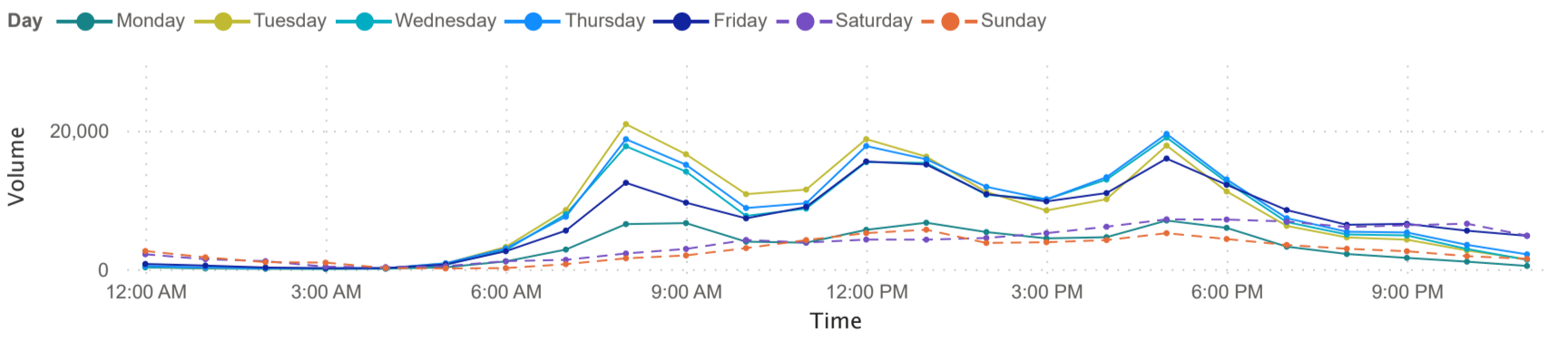

Vehicle volumes

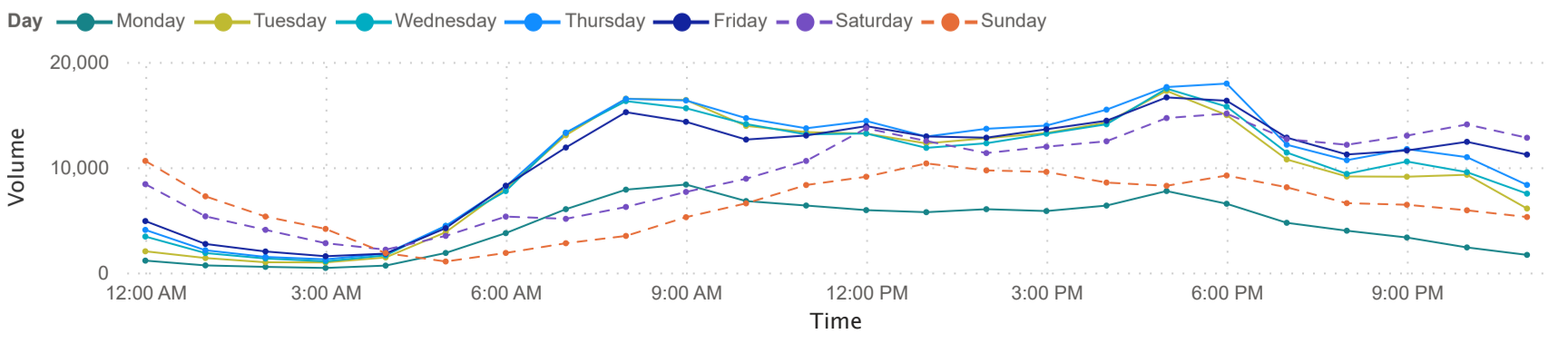
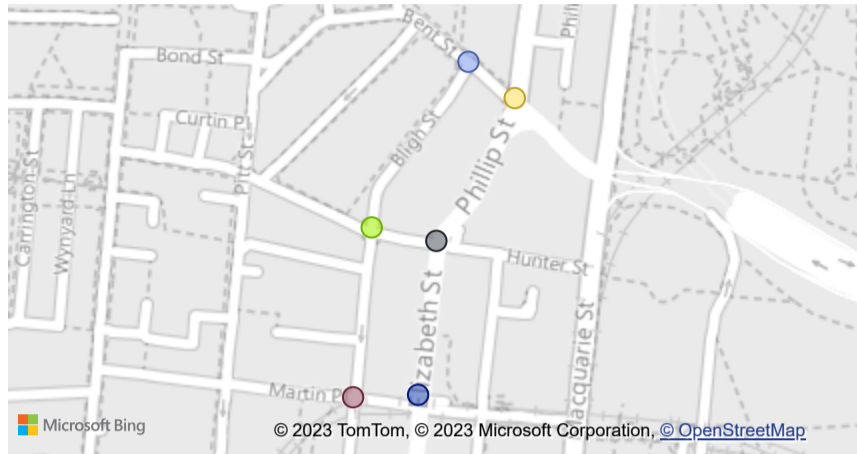

FIGURE 5-XX

> **Martin Place Station** **6** **Intersections**

Map

ID ● MPL01 ● MPL02 ● MPL03 ● MPL04 ● MPL05 ● MPL06



Total Mode Split

Mode ● Buses ● Cyclists ● Heavy Vehicles ● Light Vehicles



% Mode Split

| Day     | Buses | Cyclists | Heavy Vehicles | Light Vehicles |
|---------|-------|----------|----------------|----------------|
| Weekday | 8.3%  | 1.1%     | 4.3%           | 86.3%          |
| Weekend | 8.4%  | 0.6%     | 1.6%           | 89.3%          |

Average daily vehicles and cyclists profile for a weekday and weekend

Day ● Weekday ● Weekend

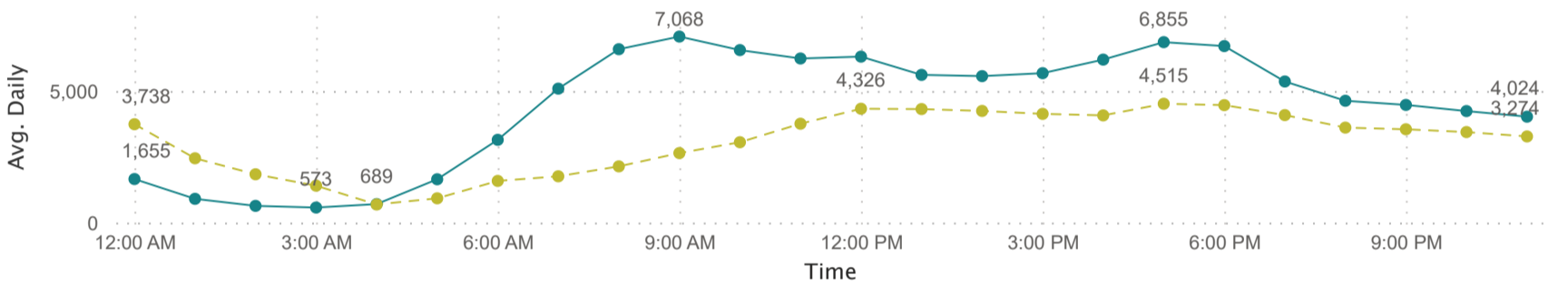

Cyclists volumes

Day ● Monday ● Tuesday ● Wednesday ● Thursday ● Friday ● Saturday ● Sunday

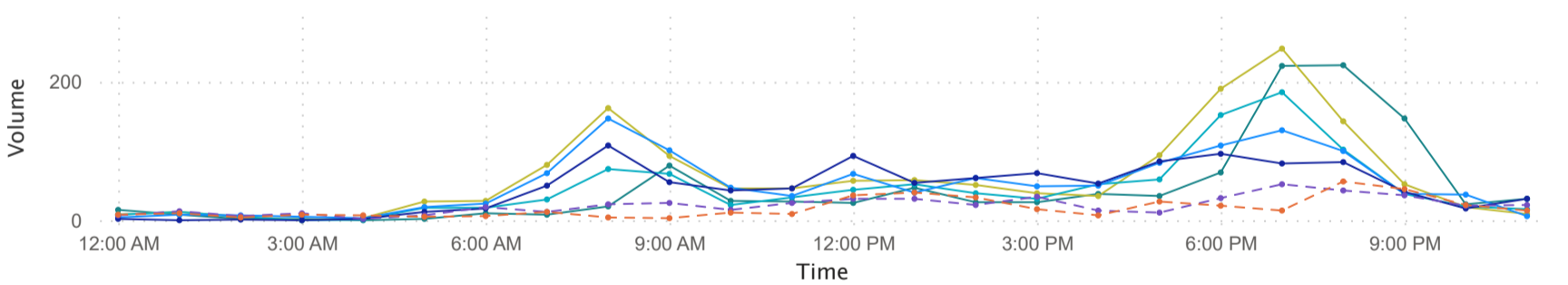

Pedestrian volumes

Day ● Monday ● Tuesday ● Wednesday ● Thursday ● Friday ● Saturday ● Sunday

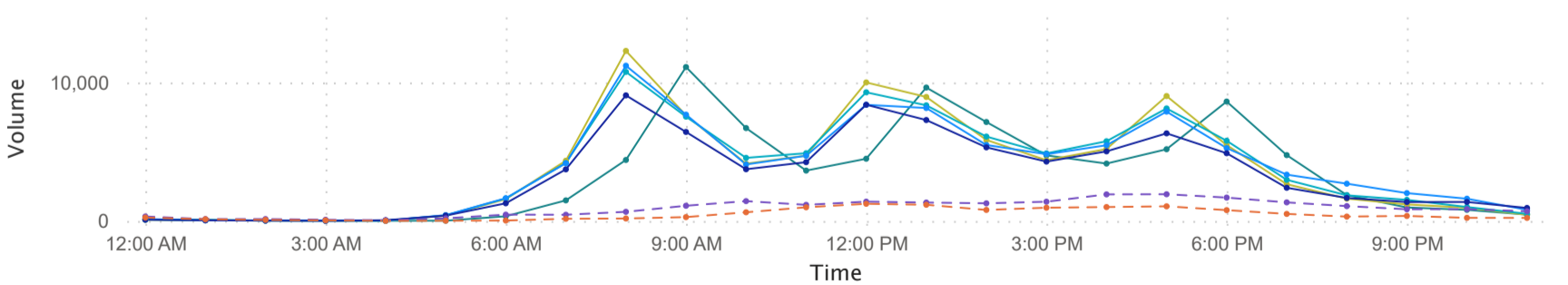

Vehicle volumes

Day ● Monday ● Tuesday ● Wednesday ● Thursday ● Friday ● Saturday ● Sunday

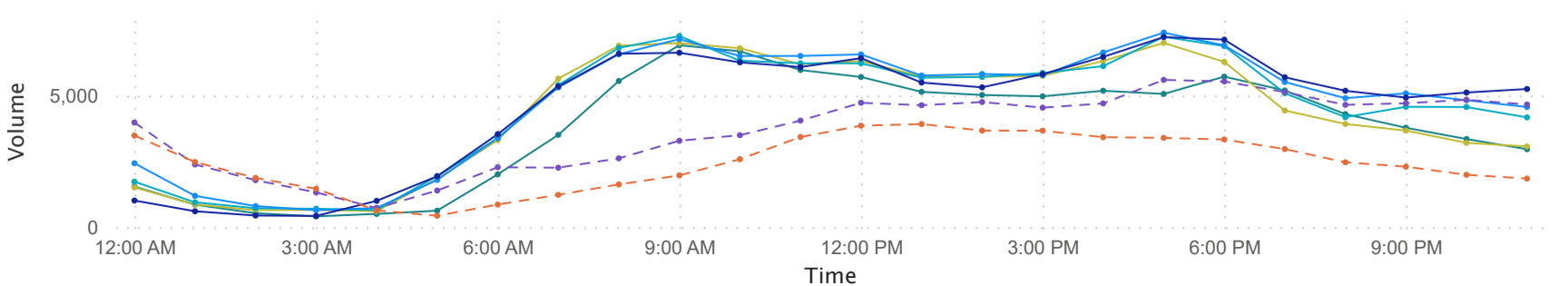

FIGURE 5-XX

## > Pitt Street Station 4 Intersections

### Map

ID ● PIT01 ● PIT02 ● PIT03 ● PIT04



### Total Mode Split

Mode ● Buses ● Cyclists ● Heavy Vehicles ● Light Vehicles

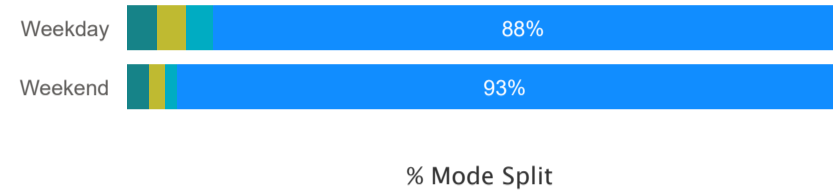

| Day     | Buses | Cyclists | Heavy Vehicles | Light Vehicles |
|---------|-------|----------|----------------|----------------|
| Weekday | 4.2%  | 4.2%     | 3.8%           | 87.8%          |
| Weekend | 3.1%  | 2.4%     | 1.6%           | 93.0%          |

### Average daily vehicles and cyclists profile for a weekday and weekend

Day ● Weekday ● Weekend

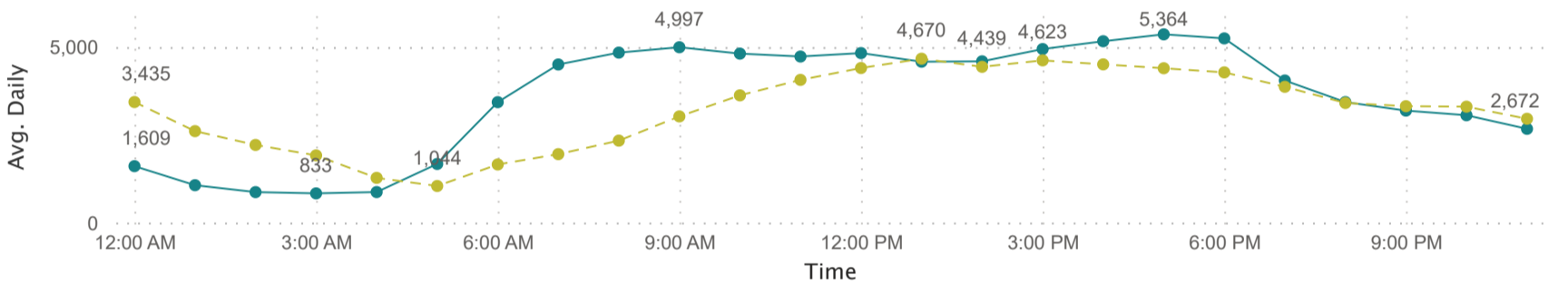

### Cyclists volumes

Day ● Monday ● Tuesday ● Wednesday ● Thursday ● Friday ● Saturday ● Sunday

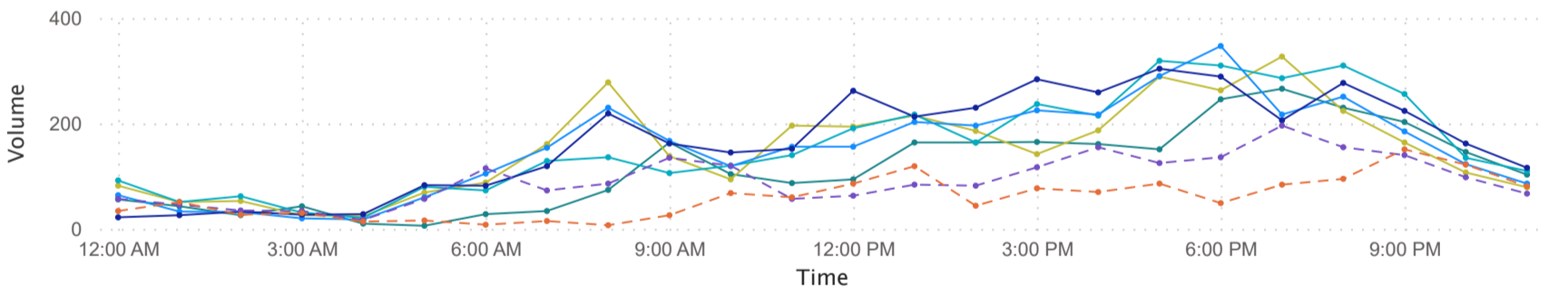

### Pedestrian volumes

Day ● Monday ● Tuesday ● Wednesday ● Thursday ● Friday ● Saturday ● Sunday

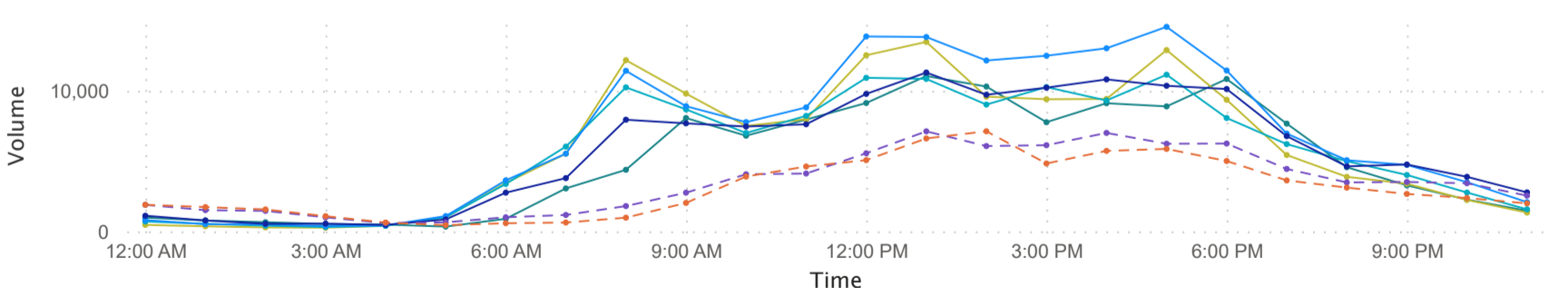

### Vehicle volumes

Day ● Monday ● Tuesday ● Wednesday ● Thursday ● Friday ● Saturday ● Sunday

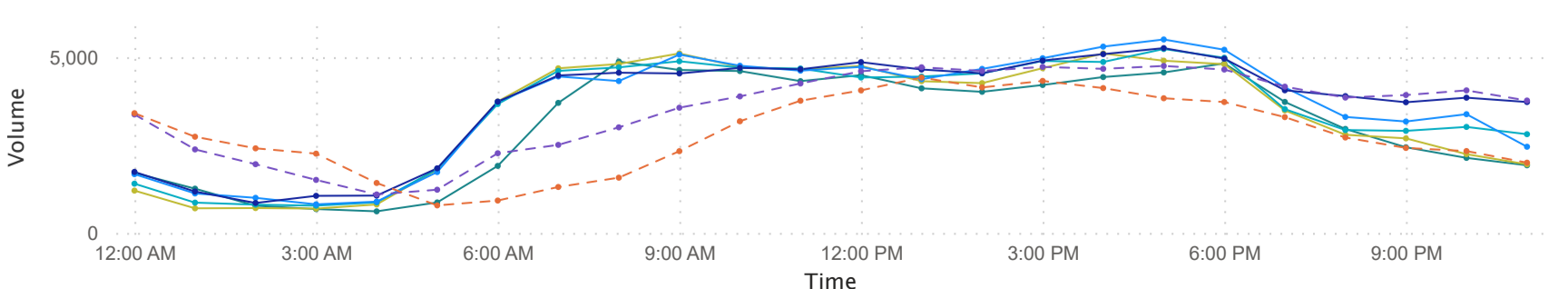
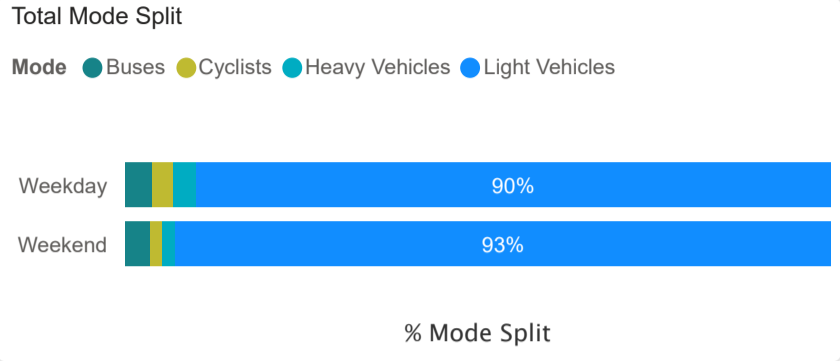
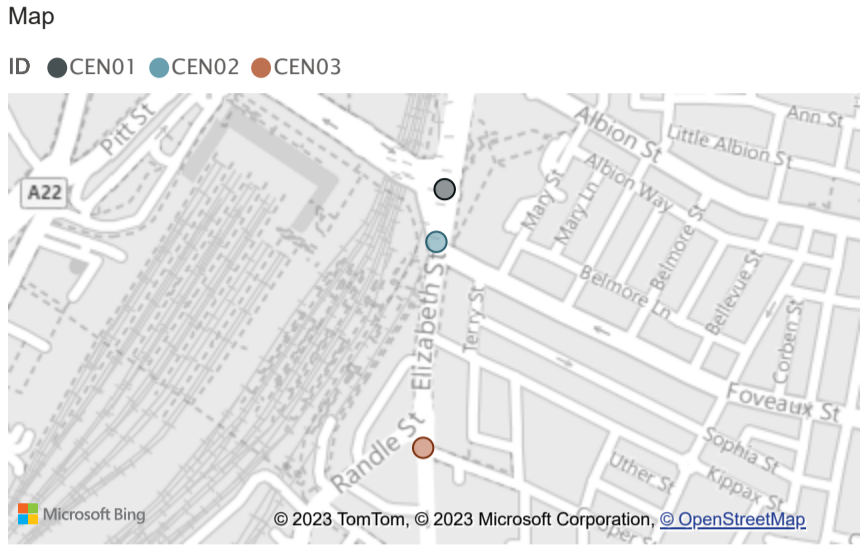

FIGURE 5-XX

> **Central Station**      **3**      **Intersections**



| Day     | Buses | Cyclists | Heavy Vehicles | Light Vehicles |
|---------|-------|----------|----------------|----------------|
| Weekday | 3.7%  | 3.1%     | 3.1%           | 90.0%          |
| Weekend | 3.6%  | 1.6%     | 1.9%           | 92.9%          |

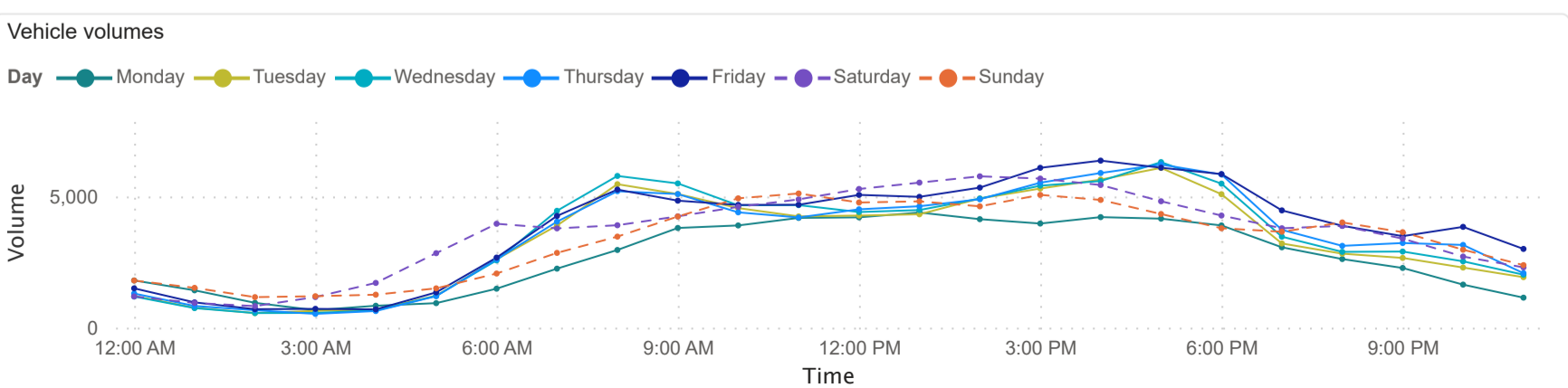
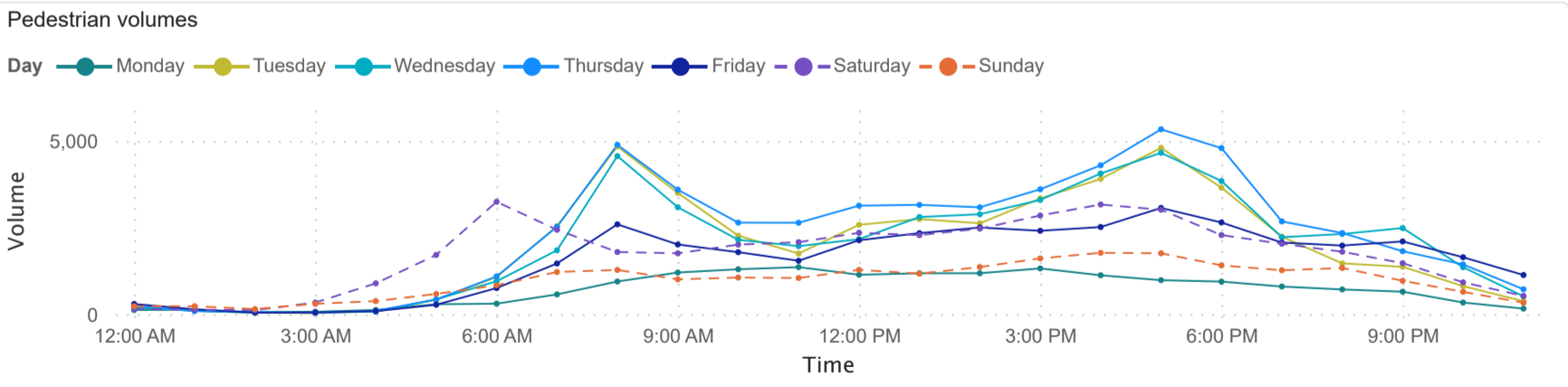
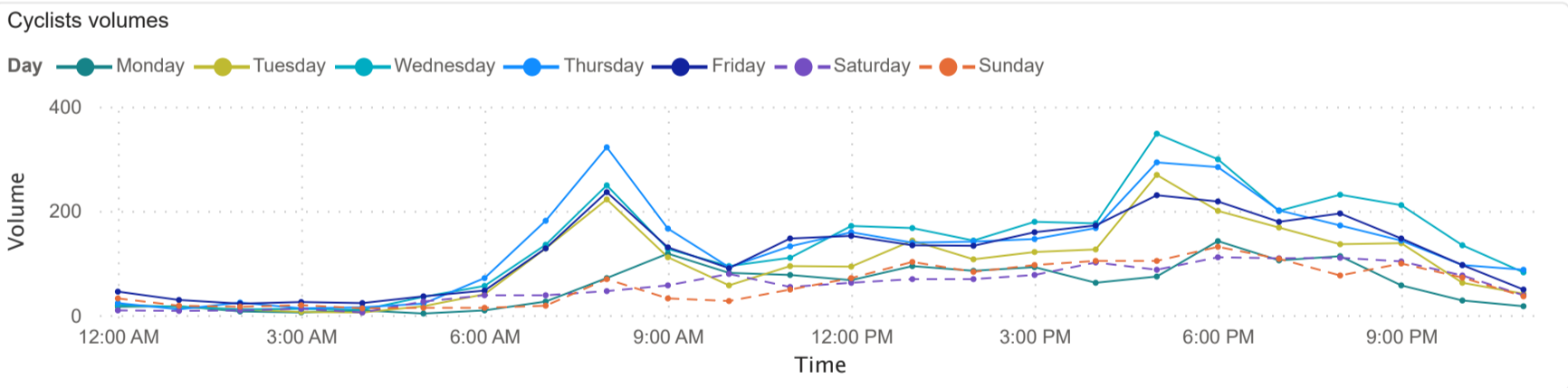
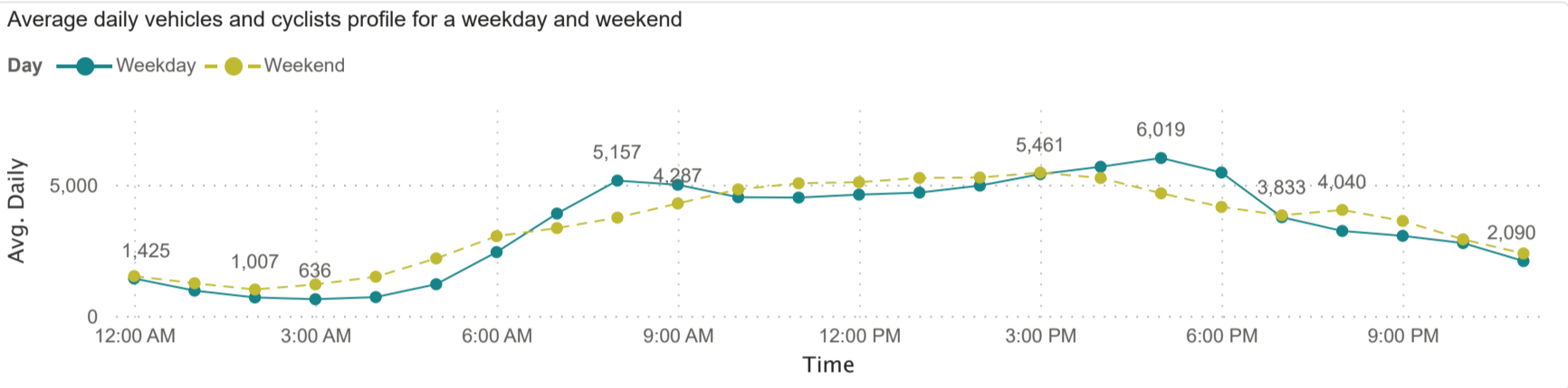

FIGURE 5-XX

**> Waterloo Station 5 Intersections**

Map

ID ● WLO01 ● WLO02 ● WLO03 ● WLO04 ● WLO05



Total Mode Split

Mode ● Buses ● Cyclists ● Heavy Vehicles ● Light Vehicles

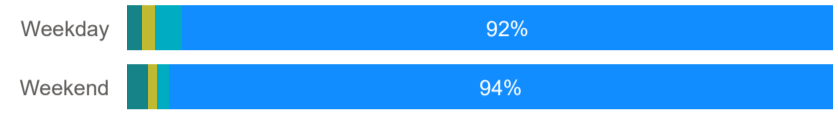

% Mode Split

| Day     | Buses | Cyclists | Heavy Vehicles | Light Vehicles |
|---------|-------|----------|----------------|----------------|
| Weekday | 2.1%  | 1.8%     | 3.9%           | 92.2%          |
| Weekend | 2.9%  | 1.4%     | 1.6%           | 94.1%          |

Average daily vehicles and cyclists profile for a weekday and weekend

Day ● Weekday ● Weekend

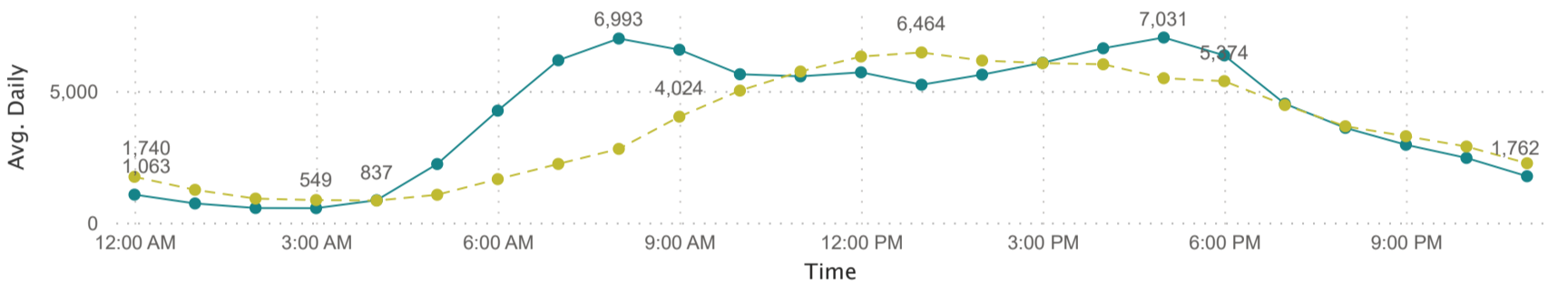

Cyclists volumes

Day ● Monday ● Tuesday ● Wednesday ● Thursday ● Friday ● Saturday ● Sunday

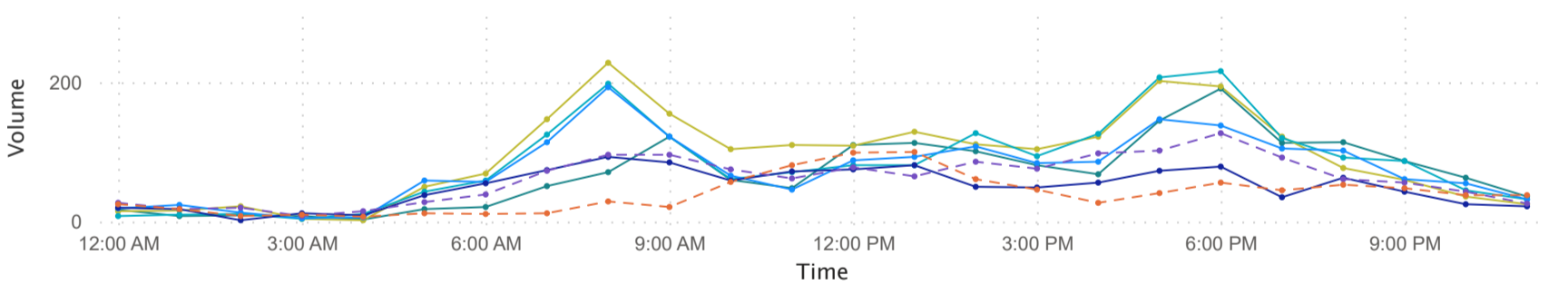

Pedestrian volumes

Day ● Monday ● Tuesday ● Wednesday ● Thursday ● Friday ● Saturday ● Sunday

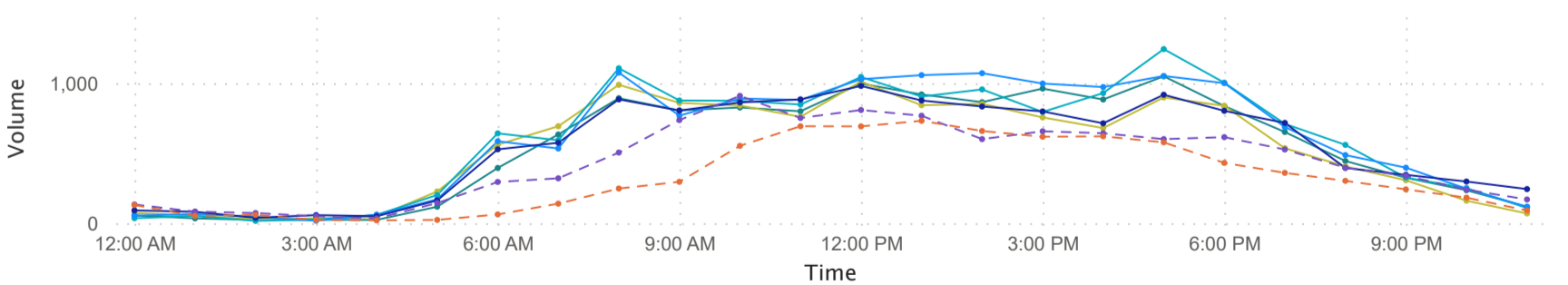

Vehicle volumes

Day ● Monday ● Tuesday ● Wednesday ● Thursday ● Friday ● Saturday ● Sunday

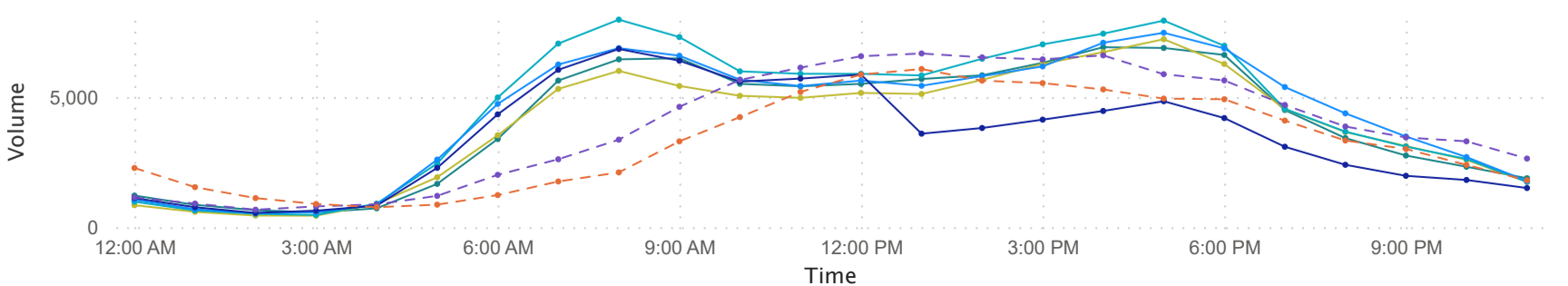

FIGURE 5-XX



> **Sydenham Station** **6** **Intersections**

Map

ID ● SYD01 ● SYD02 ● SYD03 ● SYD04 ● SYD05 ● SYD06

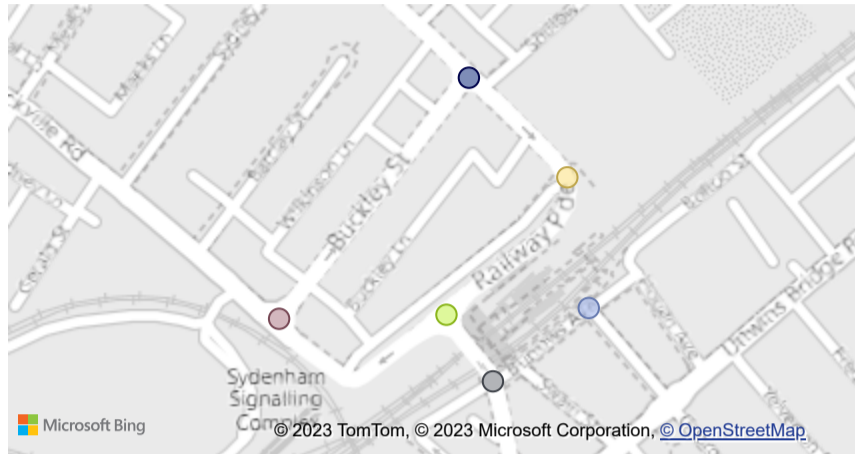

Total Mode Split

Mode ● Buses ● Cyclists ● Heavy Vehicles ● Light Vehicles

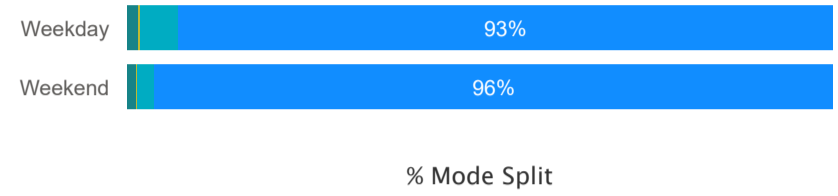

| Day     | Buses | Cyclists | Heavy Vehicles | Light Vehicles |
|---------|-------|----------|----------------|----------------|
| Weekday | 1.6%  | 0.3%     | 5.3%           | 92.8%          |
| Weekend | 1.2%  | 0.2%     | 2.4%           | 96.1%          |

Average daily vehicles and cyclists profile for a weekday and weekend

Day ● Weekday ● Weekend

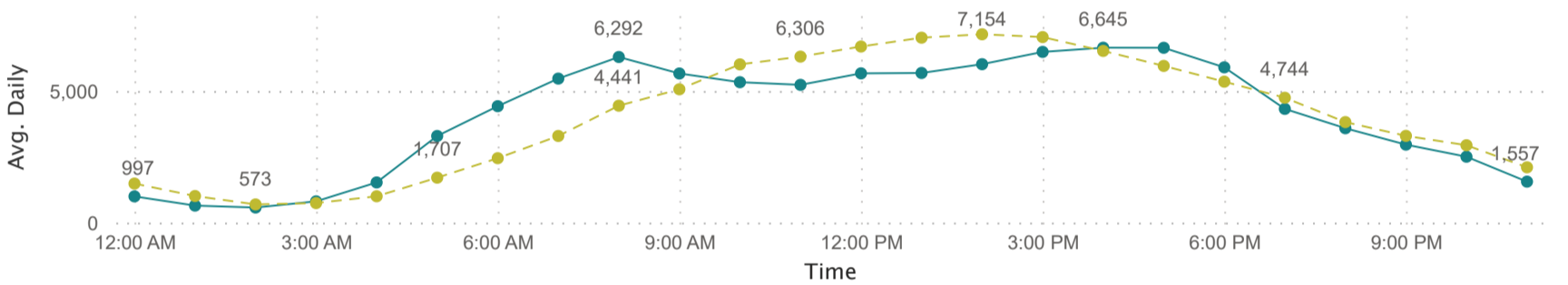

Cyclists volumes

Day ● Monday ● Tuesday ● Wednesday ● Thursday ● Friday ● Saturday ● Sunday

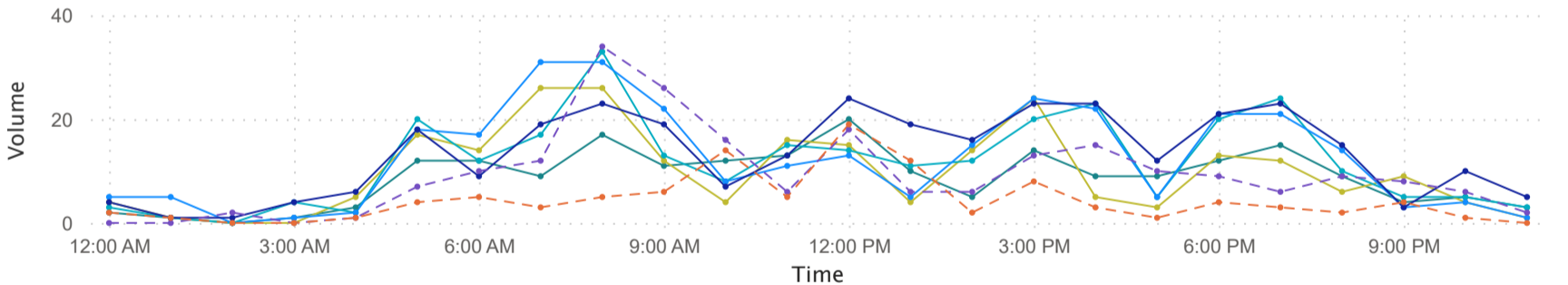

Pedestrian volumes

Day ● Monday ● Tuesday ● Wednesday ● Thursday ● Friday ● Saturday ● Sunday

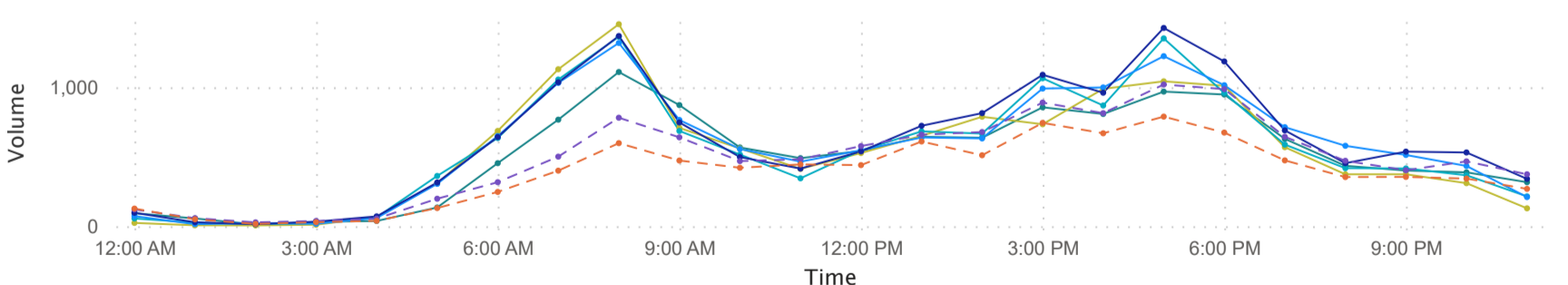

Vehicle volumes

Day ● Monday ● Tuesday ● Wednesday ● Thursday ● Friday ● Saturday ● Sunday

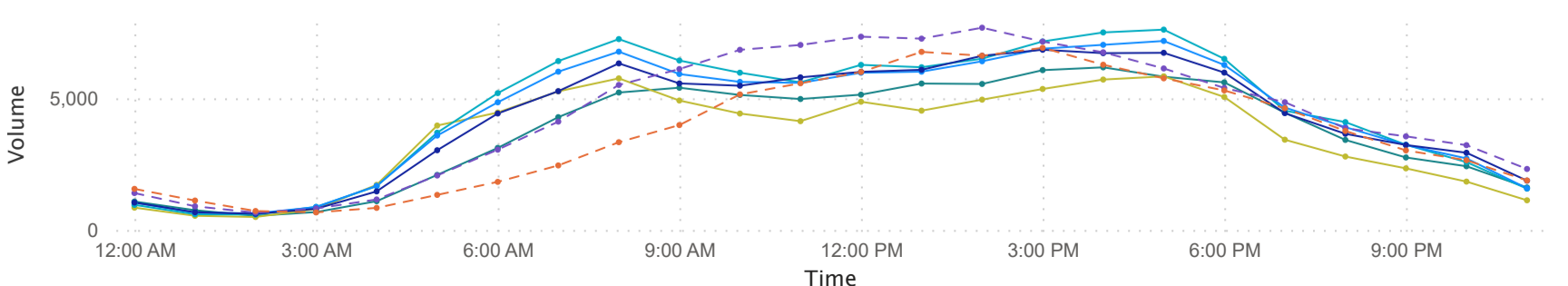

FIGURE 5-XX



# Appendix E

## Movement Summary Outputs

Appendix E Movement Summary Outputs

# MOVEMENT SUMMARY

**Site: CWD01 [CWD01 Mowbray Rd / Hampden Rd (Site Folder: Block 1 Model - 2023 AM Peak)]**

Output produced by SIDRA INTERSECTION Version: 9.1.1.200

TCS 3037

Site Category: (None)

Signals - EQUISAT (Fixed-Time/SCATS) Isolated Cycle Time = 148 seconds (Site User-Given Phase Times)

| Vehicle Movement Performance |      |           |              |      |               |      |           |             |                  |                   |          |           |                |                     |             |
|------------------------------|------|-----------|--------------|------|---------------|------|-----------|-------------|------------------|-------------------|----------|-----------|----------------|---------------------|-------------|
| Mov ID                       | Turn | Mov Class | Demand Flows |      | Arrival Flows |      | Deg. Satn | Aver. Delay | Level of Service | 95% Back Of Queue |          | Prop. Que | Eff. Stop Rate | Aver. No. of Cycles | Aver. Speed |
|                              |      |           | [ Total HV ] | %    | [ Total HV ]  | %    | v/c       | sec         |                  | [ Veh. veh        | Dist ] m |           |                |                     | km/h        |
| South: Hampden Rd (S)        |      |           |              |      |               |      |           |             |                  |                   |          |           |                |                     |             |
| 21                           | L2   | All MCs   | 239          | 0.9  | 239           | 0.9  | * 0.641   | 64.5        | LOS E            | 15.0              | 105.7    | 0.97      | 1.02           | 0.97                | 17.1        |
| Approach                     |      |           | 239          | 0.9  | 239           | 0.9  | 0.641     | 64.5        | LOS E            | 15.0              | 105.7    | 0.97      | 1.02           | 0.97                | 17.1        |
| East: Mowbray Rd (E)         |      |           |              |      |               |      |           |             |                  |                   |          |           |                |                     |             |
| 24                           | L2   | All MCs   | 113          | 0.9  | 113           | 0.9  | * 0.409   | 16.7        | LOS B            | 16.5              | 118.0    | 0.49      | 0.50           | 0.49                | 35.6        |
| 25                           | T1   | All MCs   | 918          | 3.2  | 918           | 3.2  | 0.409     | 11.7        | LOS A            | 16.6              | 119.3    | 0.49      | 0.47           | 0.49                | 30.6        |
| Approach                     |      |           | 1031         | 3.0  | 1031          | 3.0  | 0.409     | 12.2        | LOS A            | 16.6              | 119.3    | 0.49      | 0.47           | 0.49                | 31.4        |
| North: Dive Site Access (N)  |      |           |              |      |               |      |           |             |                  |                   |          |           |                |                     |             |
| 27                           | L2   | All MCs   | 1            | 0.0  | 1             | 0.0  | 0.001     | 2.7         | LOS A            | 0.0               | 0.0      | 0.08      | 0.42           | 0.08                | 36.3        |
| 29                           | R2   | All MCs   | 8            | 25.0 | 8             | 25.0 | * 0.426   | 94.2        | LOS F            | 0.7               | 6.0      | 1.00      | 0.68           | 1.04                | 5.1         |
| Approach                     |      |           | 9            | 22.2 | 9             | 22.2 | 0.426     | 84.0        | LOS F            | 0.7               | 6.0      | 0.90      | 0.65           | 0.93                | 5.7         |
| West: Mowbray Rd (W)         |      |           |              |      |               |      |           |             |                  |                   |          |           |                |                     |             |
| 31                           | T1   | All MCs   | 988          | 2.8  | 988           | 2.8  | 0.301     | 1.9         | LOS A            | 6.3               | 45.3     | 0.20      | 0.18           | 0.20                | 45.5        |
| 32                           | R2   | All MCs   | 458          | 0.5  | 458           | 0.5  | * 0.531   | 9.6         | LOS A            | 12.3              | 86.5     | 0.47      | 0.71           | 0.47                | 37.4        |
| Approach                     |      |           | 1446         | 2.0  | 1446          | 2.0  | 0.531     | 4.3         | LOS A            | 12.3              | 86.5     | 0.28      | 0.35           | 0.28                | 41.4        |
| All Vehicles                 |      |           | 2725         | 2.4  | 2725          | 2.4  | 0.641     | 12.9        | LOS A            | 16.6              | 119.3    | 0.42      | 0.46           | 0.42                | 31.9        |

Site Level of Service (LOS) Method: Delay (RTA NSW). Site LOS Method is specified in the Parameter Settings dialog (Options tab).

Vehicle movement LOS values are based on average delay per movement.

Intersection and Approach LOS values are based on average delay for all vehicle movements.

Delay Model: SIDRA Standard (Control Delay: Geometric Delay is included).

Queue Model: SIDRA queue estimation methods are used for Back of Queue and Queue at Start of Green.

Gap-Acceptance Capacity Formula: SIDRA Standard (Akçelik M3D).

HV (%) values are calculated for All Movement Classes of All Heavy Vehicle Model Designation.

Arrival Flows used in performance calculations are adjusted to include any Initial Queued Demand and Upstream Capacity Constraint effects.

\* Critical Movement (Signal Timing)

| Pedestrian Movement Performance |          |            |           |             |                  |                       |        |           |                |             |              |             |
|---------------------------------|----------|------------|-----------|-------------|------------------|-----------------------|--------|-----------|----------------|-------------|--------------|-------------|
| Mov ID                          | Crossing | Input Vol. | Dem. Flow | Aver. Delay | Level of Service | AVERAGE BACK OF QUEUE |        | Prop. Que | Eff. Stop Rate | Travel Time | Travel Dist. | Aver. Speed |
|                                 |          | ped/h      | ped/h     | sec         |                  | [ Ped                 | Dist ] |           |                | sec         | m            | m/sec       |
|                                 |          |            |           |             |                  | ped                   | m      |           |                |             |              |             |
| South: Hampden Rd (S)           |          |            |           |             |                  |                       |        |           |                |             |              |             |
| P5                              | Full     | 10         | 11        | 50.6        | LOS E            | 0.0                   | 0.0    | 0.89      | 0.89           | 217.3       | 200.0        | 0.92        |
| East: Mowbray Rd (E)            |          |            |           |             |                  |                       |        |           |                |             |              |             |
| P6                              | Full     | 14         | 15        | 62.5        | LOS F            | 0.1                   | 0.1    | 0.92      | 0.92           | 229.2       | 200.0        | 0.87        |
| North: Dive Site Access (N)     |          |            |           |             |                  |                       |        |           |                |             |              |             |
| P7                              | Full     | 1          | 1         | 69.1        | LOS F            | 0.0                   | 0.0    | 0.97      | 0.97           | 235.8       | 200.0        | 0.85        |
| All Pedestrians                 |          | 25         | 26        | 58.0        | LOS E            | 0.1                   | 0.1    | 0.91      | 0.91           | 224.7       | 200.0        | 0.89        |

Level of Service (LOS) Method: SIDRA Pedestrian LOS Method (Based on Average Delay)

Pedestrian movement LOS values are based on average delay per pedestrian movement.

Intersection LOS value for Pedestrians is based on average delay for all pedestrian movements.

**SIDRA INTERSECTION 9.1 | Copyright © 2000-2022 Akcelik and Associates Pty Ltd | sidrasolutions.com**

Organisation: AECOM AUSTRALIA PTY LTD | Licence: NETWORK / Enterprise Level 1 | Processed: Monday, 31 July 2023 1:51:29 PM

Project: C:\Users\YeungMA\AECOM\ANZ-NAC-Sydney Metro-Sydney Metro C&SW Operational Monitoring - General\400\_Technical\432\_Traffic Analysis\SIDRA Modelling\01 Models (Geometry Only)\Block 1\Rev1\_Review\01 SM C&SW\_CWD (Block 1)\_PS.sip9

# MOVEMENT SUMMARY

**Site: CWD01 [CWD01 Mowbray Rd / Hampden Rd (Site Folder: Block 1 Model - 2023 PM Peak)]**

**Output produced by SIDRA INTERSECTION Version: 9.1.1.200**

TCS 3037

Site Category: (None)

Signals - EQUISAT (Fixed-Time/SCATS) Isolated Cycle Time = 139 seconds (Site User-Given Phase Times)

| Vehicle Movement Performance |      |           |              |              |               |              |           |             |                  |                   |            |           |                |                     |             |
|------------------------------|------|-----------|--------------|--------------|---------------|--------------|-----------|-------------|------------------|-------------------|------------|-----------|----------------|---------------------|-------------|
| Mov ID                       | Turn | Mov Class | Demand Flows |              | Arrival Flows |              | Deg. Satn | Aver. Delay | Level of Service | 95% Back Of Queue |            | Prop. Que | Eff. Stop Rate | Aver. No. of Cycles | Aver. Speed |
|                              |      |           | [ Total HV ] | [ Total HV ] | [ Total HV ]  | [ Total HV ] | v/c       | sec         |                  | [ Veh. veh        | [ Dist ] m |           |                |                     | km/h        |
| South: Hampden Rd (S)        |      |           |              |              |               |              |           |             |                  |                   |            |           |                |                     |             |
| 21                           | L2   | All MCs   | 224          | 2.3          | 224           | 2.3          | * 0.574   | 56.1        | LOS D            | 12.5              | 89.4       | 0.94      | 0.97           | 0.94                | 18.7        |
| Approach                     |      |           | 224          | 2.3          | 224           | 2.3          | 0.574     | 56.1        | LOS D            | 12.5              | 89.4       | 0.94      | 0.97           | 0.94                | 18.7        |
| East: Mowbray Rd (E)         |      |           |              |              |               |              |           |             |                  |                   |            |           |                |                     |             |
| 24                           | L2   | All MCs   | 21           | 10.0         | 21            | 10.0         | * 0.555   | 21.5        | LOS B            | 25.0              | 179.4      | 0.63      | 0.58           | 0.63                | 33.1        |
| 25                           | T1   | All MCs   | 1282         | 2.5          | 1282          | 2.5          | 0.555     | 16.2        | LOS B            | 25.2              | 179.9      | 0.63      | 0.58           | 0.63                | 27.0        |
| Approach                     |      |           | 1303         | 2.6          | 1303          | 2.6          | 0.555     | 16.3        | LOS B            | 25.2              | 179.9      | 0.63      | 0.58           | 0.63                | 27.1        |
| North: Dive Site Access (N)  |      |           |              |              |               |              |           |             |                  |                   |            |           |                |                     |             |
| 27                           | L2   | All MCs   | 1            | 0.0          | 1             | 0.0          | 0.001     | 2.9         | LOS A            | 0.0               | 0.0        | 0.10      | 0.43           | 0.10                | 36.0        |
| 29                           | R2   | All MCs   | 8            | 50.0         | 8             | 50.0         | * 0.242   | 82.4        | LOS F            | 0.6               | 6.3        | 1.00      | 0.67           | 1.00                | 5.6         |
| Approach                     |      |           | 9            | 44.4         | 9             | 44.4         | 0.242     | 73.6        | LOS F            | 0.6               | 6.3        | 0.90      | 0.65           | 0.90                | 6.3         |
| West: Mowbray Rd (W)         |      |           |              |              |               |              |           |             |                  |                   |            |           |                |                     |             |
| 31                           | T1   | All MCs   | 895          | 1.3          | 895           | 1.3          | 0.281     | 2.8         | LOS A            | 6.6               | 46.9       | 0.24      | 0.22           | 0.24                | 43.6        |
| 32                           | R2   | All MCs   | 278          | 0.4          | 278           | 0.4          | * 0.445   | 13.0        | LOS A            | 8.4               | 58.9       | 0.57      | 0.74           | 0.57                | 34.8        |
| Approach                     |      |           | 1173         | 1.1          | 1173          | 1.1          | 0.445     | 5.2         | LOS A            | 8.4               | 58.9       | 0.32      | 0.34           | 0.32                | 40.0        |
| All Vehicles                 |      |           | 2709         | 2.1          | 2709          | 2.1          | 0.574     | 15.0        | LOS B            | 25.2              | 179.9      | 0.52      | 0.51           | 0.52                | 29.4        |

Site Level of Service (LOS) Method: Delay (RTA NSW). Site LOS Method is specified in the Parameter Settings dialog (Options tab).

Vehicle movement LOS values are based on average delay per movement.

Intersection and Approach LOS values are based on average delay for all vehicle movements.

Delay Model: SIDRA Standard (Control Delay: Geometric Delay is included).

Queue Model: SIDRA queue estimation methods are used for Back of Queue and Queue at Start of Green.

Gap-Acceptance Capacity Formula: SIDRA Standard (Akçelik M3D).

HV (%) values are calculated for All Movement Classes of All Heavy Vehicle Model Designation.

Arrival Flows used in performance calculations are adjusted to include any Initial Queued Demand and Upstream Capacity Constraint effects.

\* Critical Movement (Signal Timing)

| Pedestrian Movement Performance |          |            |           |             |                  |                       |        |           |                |             |              |             |
|---------------------------------|----------|------------|-----------|-------------|------------------|-----------------------|--------|-----------|----------------|-------------|--------------|-------------|
| Mov ID                          | Crossing | Input Vol. | Dem. Flow | Aver. Delay | Level of Service | AVERAGE BACK OF QUEUE |        | Prop. Que | Eff. Stop Rate | Travel Time | Travel Dist. | Aver. Speed |
|                                 |          | ped/h      | ped/h     | sec         |                  | [ Ped                 | Dist ] |           |                | sec         | m            | m/sec       |
|                                 |          |            |           |             |                  | ped                   | m      |           |                |             |              |             |
| South: Hampden Rd (S)           |          |            |           |             |                  |                       |        |           |                |             |              |             |
| P5                              | Full     | 7          | 7         | 44.9        | LOS E            | 0.0                   | 0.0    | 0.89      | 0.89           | 211.5       | 200.0        | 0.95        |
| East: Mowbray Rd (E)            |          |            |           |             |                  |                       |        |           |                |             |              |             |
| P6                              | Full     | 16         | 17        | 58.1        | LOS E            | 0.1                   | 0.1    | 0.91      | 0.91           | 224.7       | 200.0        | 0.89        |
| North: Dive Site Access (N)     |          |            |           |             |                  |                       |        |           |                |             |              |             |
| P7                              | Full     | 1          | 1         | 64.6        | LOS F            | 0.0                   | 0.0    | 0.96      | 0.96           | 231.3       | 200.0        | 0.86        |
| All Pedestrians                 |          | 24         | 25        | 54.5        | LOS E            | 0.1                   | 0.1    | 0.91      | 0.91           | 221.1       | 200.0        | 0.90        |

Level of Service (LOS) Method: SIDRA Pedestrian LOS Method (Based on Average Delay)

Pedestrian movement LOS values are based on average delay per pedestrian movement.

Intersection LOS value for Pedestrians is based on average delay for all pedestrian movements.

**SIDRA INTERSECTION 9.1 | Copyright © 2000-2022 Akcelik and Associates Pty Ltd | sidrasolutions.com**

Organisation: AECOM AUSTRALIA PTY LTD | Licence: NETWORK / Enterprise Level 1 | Processed: Monday, 31 July 2023 1:51:19 PM

Project: C:\Users\YeungMA\AECOM\ANZ-NAC-Sydney Metro-Sydney Metro C&SW Operational Monitoring - General\400\_Technical\432\_Traffic Analysis\SIDRA Modelling\01 Models (Geometry Only)\Block 1\Rev1\_Review\01 SM C&SW\_CWD (Block 1)\_PS.sip9



# MOVEMENT SUMMARY

**Site: CWD01 [CWD01 Mowbray Rd / Hampden Rd (Site Folder: Block 1 Model - 2023 Weekend Peak)]**

**Output produced by SIDRA INTERSECTION Version: 9.1.1.200**

TCS 3037

Site Category: (None)

Signals - EQUISAT (Fixed-Time/SCATS) Isolated Cycle Time = 115 seconds (Site User-Given Phase Times)

| Vehicle Movement Performance |      |           |              |     |               |     |           |             |                  |                   |          |           |                |                     |             |
|------------------------------|------|-----------|--------------|-----|---------------|-----|-----------|-------------|------------------|-------------------|----------|-----------|----------------|---------------------|-------------|
| Mov ID                       | Turn | Mov Class | Demand Flows |     | Arrival Flows |     | Deg. Satn | Aver. Delay | Level of Service | 95% Back Of Queue |          | Prop. Que | Eff. Stop Rate | Aver. No. of Cycles | Aver. Speed |
|                              |      |           | [ Total HV ] | %   | [ Total HV ]  | %   | v/c       | sec         |                  | [ Veh. veh        | Dist ] m |           |                |                     | km/h        |
| South: Hampden Rd (S)        |      |           |              |     |               |     |           |             |                  |                   |          |           |                |                     |             |
| 21                           | L2   | All MCs   | 291          | 0.7 | 291           | 0.7 | * 0.585   | 44.0        | LOS D            | 14.2              | 100.2    | 0.92      | 0.83           | 0.92                | 21.5        |
| Approach                     |      |           | 291          | 0.7 | 291           | 0.7 | 0.585     | 44.0        | LOS D            | 14.2              | 100.2    | 0.92      | 0.83           | 0.92                | 21.5        |
| East: Mowbray Rd (E)         |      |           |              |     |               |     |           |             |                  |                   |          |           |                |                     |             |
| 24                           | L2   | All MCs   | 52           | 0.0 | 52            | 0.0 | 0.441     | 15.3        | LOS B            | 14.9              | 105.6    | 0.54      | 0.51           | 0.54                | 36.7        |
| 25                           | T1   | All MCs   | 1034         | 1.9 | 1034          | 1.9 | * 0.441   | 10.8        | LOS A            | 14.9              | 106.0    | 0.54      | 0.49           | 0.54                | 31.7        |
| Approach                     |      |           | 1085         | 1.8 | 1085          | 1.8 | 0.441     | 11.0        | LOS A            | 14.9              | 106.0    | 0.54      | 0.49           | 0.54                | 32.1        |
| North: Dive Site Access (N)  |      |           |              |     |               |     |           |             |                  |                   |          |           |                |                     |             |
| 27                           | L2   | All MCs   | 1            | 0.0 | 1             | 0.0 | 0.002     | 2.6         | LOS A            | 0.0               | 0.0      | 0.06      | 0.42           | 0.06                | 36.6        |
| 29                           | R2   | All MCs   | 1            | 0.0 | 1             | 0.0 | 0.001     | 2.5         | LOS A            | 0.0               | 0.0      | 0.00      | 0.44           | 0.00                | 31.8        |
| Approach                     |      |           | 2            | 0.0 | 2             | 0.0 | 0.002     | 2.6         | LOS A            | 0.0               | 0.0      | 0.03      | 0.43           | 0.03                | 34.2        |
| West: Mowbray Rd (W)         |      |           |              |     |               |     |           |             |                  |                   |          |           |                |                     |             |
| 31                           | T1   | All MCs   | 1205         | 0.5 | 1205          | 0.5 | 0.337     | 0.5         | LOS A            | 3.7               | 26.3     | 0.12      | 0.11           | 0.12                | 48.6        |
| 32                           | R2   | All MCs   | 362          | 1.2 | 362           | 1.2 | 0.455     | 8.5         | LOS A            | 6.4               | 45.0     | 0.34      | 0.66           | 0.34                | 38.3        |
| Approach                     |      |           | 1567         | 0.7 | 1567          | 0.7 | 0.455     | 2.4         | LOS A            | 6.4               | 45.0     | 0.17      | 0.24           | 0.17                | 44.4        |
| All Vehicles                 |      |           | 2945         | 1.1 | 2945          | 1.1 | 0.585     | 9.7         | LOS A            | 14.9              | 106.0    | 0.38      | 0.39           | 0.38                | 34.6        |

Site Level of Service (LOS) Method: Delay (RTA NSW). Site LOS Method is specified in the Parameter Settings dialog (Options tab).

Vehicle movement LOS values are based on average delay per movement.

Intersection and Approach LOS values are based on average delay for all vehicle movements.

Delay Model: SIDRA Standard (Control Delay: Geometric Delay is included).

Queue Model: SIDRA queue estimation methods are used for Back of Queue and Queue at Start of Green.

Gap-Acceptance Capacity Formula: SIDRA Standard (Akçelik M3D).

HV (%) values are calculated for All Movement Classes of All Heavy Vehicle Model Designation.

Arrival Flows used in performance calculations are adjusted to include any Initial Queued Demand and Upstream Capacity Constraint effects.

\* Critical Movement (Signal Timing)

| Pedestrian Movement Performance |          |            |           |             |                  |                       |        |           |                |             |              |             |
|---------------------------------|----------|------------|-----------|-------------|------------------|-----------------------|--------|-----------|----------------|-------------|--------------|-------------|
| Mov ID                          | Crossing | Input Vol. | Dem. Flow | Aver. Delay | Level of Service | AVERAGE BACK OF QUEUE |        | Prop. Que | Eff. Stop Rate | Travel Time | Travel Dist. | Aver. Speed |
|                                 |          | ped/h      | ped/h     | sec         |                  | [ Ped                 | Dist ] |           |                | sec         | m            | m/sec       |
|                                 |          |            |           |             |                  | ped                   | m      |           |                |             |              |             |
| South: Hampden Rd (S)           |          |            |           |             |                  |                       |        |           |                |             |              |             |
| P5                              | Full     | 1          | 1         | 49.8        | LOS E            | 0.0                   | 0.0    | 0.93      | 0.93           | 216.4       | 200.0        | 0.92        |
| East: Mowbray Rd (E)            |          |            |           |             |                  |                       |        |           |                |             |              |             |
| P6                              | Full     | 8          | 8         | 46.1        | LOS E            | 0.0                   | 0.0    | 0.90      | 0.90           | 212.8       | 200.0        | 0.94        |
| North: Dive Site Access (N)     |          |            |           |             |                  |                       |        |           |                |             |              |             |
| P7                              | Full     | 1          | 1         | 28.4        | LOS C            | 0.0                   | 0.0    | 0.91      | 0.91           | 195.0       | 200.0        | 1.03        |
| All Pedestrians                 |          | 10         | 11        | 44.7        | LOS E            | 0.0                   | 0.0    | 0.90      | 0.90           | 211.4       | 200.0        | 0.95        |

Level of Service (LOS) Method: SIDRA Pedestrian LOS Method (Based on Average Delay)

Pedestrian movement LOS values are based on average delay per pedestrian movement.

Intersection LOS value for Pedestrians is based on average delay for all pedestrian movements.

**SIDRA INTERSECTION 9.1 | Copyright © 2000-2022 Akcelik and Associates Pty Ltd | sidrasolutions.com**

Organisation: AECOM AUSTRALIA PTY LTD | Licence: NETWORK / Enterprise Level 1 | Processed: Monday, 31 July 2023 1:51:43 PM

Project: C:\Users\YeungMA\AECOM\ANZ-NAC-Sydney Metro-Sydney Metro C&SW Operational Monitoring - General\400\_Technical\432\_Traffic Analysis\SIDRA Modelling\01 Models (Geometry Only)\Block 1\Rev1\_Review\01 SM C&SW\_CWD (Block 1)\_PS.sip9

# MOVEMENT SUMMARY

**Site: CST01 [CST01 Pacific Hwy / Albany St (Site Folder: Block 1 Model - 2023 AM Peak)]**

Output produced by SIDRA INTERSECTION Version: 9.1.1.200

**Network: CST-N1 [CST Network 1 (Network Folder: Block 1 Network - 2023 AM Peak)]**

TCS 768

Site Category: (None)

Signals - EQUISAT (Fixed-Time/SCATS) Coordinated Cycle Time = 135 seconds (Network Site User-Given Phase Times)

| Vehicle Movement Performance |      |           |                       |     |                       |     |           |             |                  |                   |               |           |                |                     |             |
|------------------------------|------|-----------|-----------------------|-----|-----------------------|-----|-----------|-------------|------------------|-------------------|---------------|-----------|----------------|---------------------|-------------|
| Mov ID                       | Turn | Mov Class | Demand Flows          |     | Arrival Flows         |     | Deg. Satn | Aver. Delay | Level of Service | 95% Back Of Queue |               | Prop. Que | Eff. Stop Rate | Aver. No. of Cycles | Aver. Speed |
|                              |      |           | [ Total HV ]<br>veh/h | %   | [ Total HV ]<br>veh/h | %   |           |             |                  | [ Veh. veh        | [ Dist ]<br>m |           |                |                     |             |
| SouthEast: Pacific Hwy (SE)  |      |           |                       |     |                       |     |           |             |                  |                   |               |           |                |                     |             |
| 22                           | T1   | All MCs   | 1112                  | 4.7 | 1112                  | 4.7 | 0.407     | 6.0         | LOS A            | 12.8              | 93.4          | 0.36      | 0.33           | 0.36                | 45.4        |
| 23b                          | R3   | All MCs   | 151                   | 2.1 | 151                   | 2.1 | *0.851    | 83.1        | LOS F            | 10.7              | 76.3          | 1.00      | 0.91           | 1.15                | 6.5         |
| Approach                     |      |           | 1262                  | 4.4 | 1262                  | 4.4 | 0.851     | 15.2        | LOS B            | 12.8              | 93.4          | 0.44      | 0.40           | 0.46                | 32.2        |
| East: Albany St (E)          |      |           |                       |     |                       |     |           |             |                  |                   |               |           |                |                     |             |
| 4b                           | L3   | All MCs   | 23                    | 0.0 | 23                    | 0.0 | *0.881    | 83.0        | LOS F            | 6.9               | 49.0          | 1.00      | 1.00           | 1.24                | 2.1         |
| 6a                           | R1   | All MCs   | 518                   | 2.4 | 518                   | 2.4 | 0.881     | 72.0        | LOS F            | 6.9               | 49.0          | 1.00      | 1.00           | 1.23                | 8.2         |
| Approach                     |      |           | 541                   | 2.3 | 541                   | 2.3 | 0.881     | 72.5        | LOS F            | 6.9               | 49.0          | 1.00      | 1.00           | 1.23                | 8.0         |
| NorthWest: Pacific Hwy (NW)  |      |           |                       |     |                       |     |           |             |                  |                   |               |           |                |                     |             |
| 27a                          | L1   | All MCs   | 411                   | 1.5 | 411                   | 1.5 | 0.362     | 9.9         | LOS A            | 6.6               | 47.0          | 0.27      | 0.64           | 0.27                | 30.0        |
| 28                           | T1   | All MCs   | 1271                  | 6.1 | 1271                  | 6.1 | *0.596    | 19.3        | LOS B            | 26.3              | 194.1         | 0.69      | 0.63           | 0.69                | 20.4        |
| Approach                     |      |           | 1681                  | 5.0 | 1681                  | 5.0 | 0.596     | 17.1        | LOS B            | 26.3              | 194.1         | 0.59      | 0.63           | 0.59                | 22.2        |
| All Vehicles                 |      |           | 3484                  | 4.4 | 3484                  | 4.4 | 0.881     | 25.0        | LOS B            | 26.3              | 194.1         | 0.60      | 0.61           | 0.64                | 20.3        |

Site Level of Service (LOS) Method: Delay (RTA NSW). Site LOS Method is specified in the Network Data dialog (Override Site Data tab).

Vehicle movement LOS values are based on average delay per movement.

Intersection and Approach LOS values are based on average delay for all vehicle movements.

Delay Model: SIDRA Standard (Control Delay: Geometric Delay is included).

Queue Model: SIDRA queue estimation methods are used for Back of Queue and Queue at Start of Green.

Gap-Acceptance Capacity Formula: SIDRA Standard (Akçelik M3D).

HV (%) values are calculated for All Movement Classes of All Heavy Vehicle Model Designation.

Arrival Flows used in performance calculations are adjusted to include any Initial Queued Demand and Upstream Capacity Constraint effects.

\* Critical Movement (Signal Timing)

| Pedestrian Movement Performance |          |           |             |                  |                       |        |           |                |             |              |             |
|---------------------------------|----------|-----------|-------------|------------------|-----------------------|--------|-----------|----------------|-------------|--------------|-------------|
| Mov ID                          | Crossing | Dem. Flow | Aver. Delay | Level of Service | AVERAGE BACK OF QUEUE |        | Prop. Que | Eff. Stop Rate | Travel Time | Travel Dist. | Aver. Speed |
|                                 |          | ped/h     | sec         |                  | [ Ped                 | Dist ] |           |                | sec         | m            | m/sec       |
|                                 |          |           |             |                  | ped                   | m      |           |                |             |              |             |
| SouthEast: Pacific Hwy (SE)     |          |           |             |                  |                       |        |           |                |             |              |             |
| P5                              | Full     | 163       | 55.5        | LOS E            | 0.6                   | 0.6    | 0.91      | 0.91           | 222.2       | 200.0        | 0.90        |
| East: Albany St (E)             |          |           |             |                  |                       |        |           |                |             |              |             |
| P2                              | Full     | 198       | 55.6        | LOS E            | 0.7                   | 0.7    | 0.91      | 0.91           | 72.3        | 20.0         | 0.28        |
| All Pedestrians                 |          | 361       | 55.5        | LOS E            | 0.7                   | 0.7    | 0.91      | 0.91           | 140.0       | 101.3        | 0.72        |

Level of Service (LOS) Method: SIDRA Pedestrian LOS Method (Based on Average Delay)

Pedestrian movement LOS values are based on average delay per pedestrian movement.

Intersection LOS value for Pedestrians is based on average delay for all pedestrian movements.

---

**SIDRA INTERSECTION 9.1 | Copyright © 2000-2022 Akcelik and Associates Pty Ltd | sidrasolutions.com**

Organisation: AECOM AUSTRALIA PTY LTD | Licence: NETWORK / Enterprise Level 1 | Processed: Monday, 17 July 2023 1:41:23 PM

Project: C:\Users\YeungMA\AECOM\ANZ-NAC-Sydney Metro-Sydney Metro C&SW Operational Monitoring - General\400\_Technical\432\_Traffic Analysis\SIDRA Modelling\01 Models (Geometry Only)\Block 1\Rev1\_Review\02 SM C&SW\_CST (Block 1)\_PS.sip9

# MOVEMENT SUMMARY

**Site: CST02 [CST02 Pacific Hwy / Oxley St (Site Folder: Block 1 Model - 2023 AM Peak)]**

Output produced by SIDRA INTERSECTION Version: 9.1.1.200

**Network: CST-N1 [CST Network 1 (Network Folder: Block 1 Network - 2023 AM Peak)]**

TCS 767

Site Category: (None)

Signals - EQUISAT (Fixed-Time/SCATS) Coordinated Cycle Time = 135 seconds (Network Site User-Given Phase Times)

| Vehicle Movement Performance |      |           |                       |     |                       |     |           |             |                  |                   |               |           |                |                     |             |
|------------------------------|------|-----------|-----------------------|-----|-----------------------|-----|-----------|-------------|------------------|-------------------|---------------|-----------|----------------|---------------------|-------------|
| Mov ID                       | Turn | Mov Class | Demand Flows          |     | Arrival Flows         |     | Deg. Satn | Aver. Delay | Level of Service | 95% Back Of Queue |               | Prop. Que | Eff. Stop Rate | Aver. No. of Cycles | Aver. Speed |
|                              |      |           | [ Total HV ]<br>veh/h | %   | [ Total HV ]<br>veh/h | %   |           |             |                  | [ Veh. veh        | [ Dist ]<br>m |           |                |                     |             |
| SouthEast: Pacific Hwy (SE)  |      |           |                       |     |                       |     |           |             |                  |                   |               |           |                |                     |             |
| 1                            | L2   | All MCs   | 135                   | 2.3 | 135                   | 2.3 | 0.144     | 12.4        | LOS A            | 1.7               | 12.3          | 0.17      | 0.52           | 0.17                | 38.7        |
| 2                            | T1   | All MCs   | 1139                  | 4.5 | 1139                  | 4.5 | 0.470     | 4.7         | LOS A            | 7.3               | 53.4          | 0.21      | 0.21           | 0.21                | 42.1        |
| Approach                     |      |           | 1274                  | 4.3 | 1274                  | 4.3 | 0.470     | 5.5         | LOS A            | 7.3               | 53.4          | 0.21      | 0.24           | 0.21                | 41.2        |
| NorthEast: Oxley St (NE)     |      |           |                       |     |                       |     |           |             |                  |                   |               |           |                |                     |             |
| 4                            | L2   | All MCs   | 85                    | 2.5 | 85                    | 2.5 | 0.255     | 53.9        | LOS D            | 4.8               | 34.5          | 0.90      | 0.76           | 0.90                | 2.9         |
| 5                            | T1   | All MCs   | 155                   | 0.7 | 155                   | 0.7 | *0.490    | 56.0        | LOS D            | 7.0               | 49.0          | 0.96      | 0.78           | 0.96                | 14.2        |
| Approach                     |      |           | 240                   | 1.3 | 240                   | 1.3 | 0.490     | 55.3        | LOS D            | 7.0               | 49.0          | 0.94      | 0.77           | 0.94                | 11.0        |
| NorthWest: Pacific Hwy (NW)  |      |           |                       |     |                       |     |           |             |                  |                   |               |           |                |                     |             |
| 7                            | L2   | All MCs   | 71                    | 1.5 | 71                    | 1.5 | 0.059     | 6.5         | LOS A            | 0.2               | 1.3           | 0.04      | 0.59           | 0.04                | 35.9        |
| 8                            | T1   | All MCs   | 1224                  | 6.3 | 1224                  | 6.3 | *0.479    | 0.6         | LOS A            | 2.6               | 19.5          | 0.06      | 0.05           | 0.06                | 56.3        |
| Approach                     |      |           | 1295                  | 6.0 | 1295                  | 6.0 | 0.479     | 1.0         | LOS A            | 2.6               | 19.5          | 0.06      | 0.08           | 0.06                | 54.6        |
| SouthWest: Oxley St (SW)     |      |           |                       |     |                       |     |           |             |                  |                   |               |           |                |                     |             |
| 10                           | L2   | All MCs   | 124                   | 3.4 | 124                   | 3.4 | 0.334     | 53.9        | LOS D            | 7.0               | 50.5          | 0.90      | 0.78           | 0.90                | 13.3        |
| 11                           | T1   | All MCs   | 152                   | 0.0 | 152                   | 0.0 | 0.375     | 49.6        | LOS D            | 8.6               | 60.2          | 0.91      | 0.74           | 0.91                | 14.4        |
| 12                           | R2   | All MCs   | 97                    | 3.3 | 97                    | 3.3 | 0.576     | 67.7        | LOS E            | 6.3               | 45.3          | 0.99      | 0.79           | 0.99                | 11.2        |
| Approach                     |      |           | 373                   | 2.0 | 373                   | 2.0 | 0.576     | 55.8        | LOS D            | 8.6               | 60.2          | 0.93      | 0.77           | 0.93                | 13.1        |
| All Vehicles                 |      |           | 3181                  | 4.5 | 3181                  | 4.5 | 0.576     | 13.3        | LOS A            | 8.6               | 60.2          | 0.29      | 0.28           | 0.29                | 26.6        |

Site Level of Service (LOS) Method: Delay (RTA NSW). Site LOS Method is specified in the Network Data dialog (Override Site Data tab).

Vehicle movement LOS values are based on average delay per movement.

Intersection and Approach LOS values are based on average delay for all vehicle movements.

Delay Model: SIDRA Standard (Control Delay: Geometric Delay is included).

Queue Model: SIDRA queue estimation methods are used for Back of Queue and Queue at Start of Green.

Gap-Acceptance Capacity Formula: SIDRA Standard (Akçelik M3D).

HV (%) values are calculated for All Movement Classes of All Heavy Vehicle Model Designation.

Arrival Flows used in performance calculations are adjusted to include any Initial Queued Demand and Upstream Capacity Constraint effects.

\* Critical Movement (Signal Timing)

| Pedestrian Movement Performance |          |           |             |                  |                       |        |           |                |             |              |             |
|---------------------------------|----------|-----------|-------------|------------------|-----------------------|--------|-----------|----------------|-------------|--------------|-------------|
| Mov ID                          | Crossing | Dem. Flow | Aver. Delay | Level of Service | AVERAGE BACK OF QUEUE |        | Prop. Que | Eff. Stop Rate | Travel Time | Travel Dist. | Aver. Speed |
|                                 |          | ped/h     | sec         |                  | [ Ped                 | Dist ] |           |                | sec         | m            | m/sec       |
|                                 |          |           |             |                  | ped                   | m      |           |                |             |              |             |
| SouthEast: Pacific Hwy (SE)     |          |           |             |                  |                       |        |           |                |             |              |             |
| P1                              | Full     | 86        | 55.3        | LOS E            | 0.3                   | 0.3    | 0.91      | 0.91           | 72.0        | 20.0         | 0.28        |
| NorthEast: Oxley St (NE)        |          |           |             |                  |                       |        |           |                |             |              |             |
| P2                              | Full     | 73        | 56.2        | LOS E            | 0.3                   | 0.3    | 0.91      | 0.91           | 72.9        | 20.0         | 0.27        |
| SouthWest: Oxley St (SW)        |          |           |             |                  |                       |        |           |                |             |              |             |
| P4                              | Full     | 111       | 56.3        | LOS E            | 0.4                   | 0.4    | 0.92      | 0.92           | 73.0        | 20.0         | 0.27        |
| All Pedestrians                 |          | 269       | 56.0        | LOS E            | 0.4                   | 0.4    | 0.91      | 0.91           | 72.6        | 20.0         | 0.28        |

Level of Service (LOS) Method: SIDRA Pedestrian LOS Method (Based on Average Delay)

Pedestrian movement LOS values are based on average delay per pedestrian movement.

Intersection LOS value for Pedestrians is based on average delay for all pedestrian movements.

**SIDRA INTERSECTION 9.1 | Copyright © 2000-2022 Akcelik and Associates Pty Ltd | sidrasolutions.com**

Organisation: AECOM AUSTRALIA PTY LTD | Licence: NETWORK / Enterprise Level 1 | Processed: Monday, 17 July 2023 1:41:23 PM

Project: C:\Users\YeungM\AECOM\ANZ-NAC-Sydney Metro-Sydney Metro C&SW Operational Monitoring - General\400\_Technical\432\_Traffic Analysis\SIDRA Modelling\01 Models (Geometry Only)\Block 1\Rev1\_Review\02 SM C&SW\_CST (Block 1)\_PS.sip9



# MOVEMENT SUMMARY

Site: CST03 [CST03 Pacific Hwy / Hume St (Site Folder: Block 1 Model - 2023 AM Peak)]

Output produced by SIDRA INTERSECTION Version: 9.1.1.200

Network: CST-N1 [CST Network 1 (Network Folder: Block 1 Network - 2023 AM Peak)]

TCS 766

Site Category: (None)

Signals - EQUISAT (Fixed-Time/SCATS) Coordinated Cycle Time = 135 seconds (Network Site User-Given Phase Times)

| Vehicle Movement Performance |      |           |              |       |               |       |           |             |                  |                   |        |           |                |                     |             |
|------------------------------|------|-----------|--------------|-------|---------------|-------|-----------|-------------|------------------|-------------------|--------|-----------|----------------|---------------------|-------------|
| Mov ID                       | Turn | Mov Class | Demand Flows |       | Arrival Flows |       | Deg. Satn | Aver. Delay | Level of Service | 95% Back Of Queue |        | Prop. Que | Eff. Stop Rate | Aver. No. of Cycles | Aver. Speed |
|                              |      |           | [ Total HV ] | %     | [ Total HV ]  | %     |           |             |                  | [ Veh. veh        | Dist ] |           |                |                     |             |
|                              |      |           | veh/h        | veh/h | veh/h         | veh/h | v/c       | sec         |                  |                   | m      |           |                |                     | km/h        |
| SouthEast: Pacific Hwy (SE)  |      |           |              |       |               |       |           |             |                  |                   |        |           |                |                     |             |
| 1                            | L2   | All MCs   | 53           | 2.0   | 53            | 2.0   | 0.101     | 6.0         | LOS A            | 0.2               | 1.5    | 0.02      | 0.24           | 0.02                | 35.0        |
| 2                            | T1   | All MCs   | 1181         | 4.6   | 1181          | 4.6   | 0.377     | 0.4         | LOS A            | 1.2               | 8.4    | 0.03      | 0.05           | 0.03                | 57.8        |
| Approach                     |      |           | 1234         | 4.5   | 1234          | 4.5   | 0.377     | 0.7         | LOS A            | 1.2               | 8.4    | 0.03      | 0.06           | 0.03                | 55.7        |
| NorthWest: Pacific Hwy (NW)  |      |           |              |       |               |       |           |             |                  |                   |        |           |                |                     |             |
| 8                            | T1   | All MCs   | 1407         | 5.8   | 1407          | 5.8   | 0.576     | 3.1         | LOS A            | 14.7              | 108.2  | 0.28      | 0.26           | 0.28                | 42.9        |
| 9                            | R2   | All MCs   | 100          | 0     | 100           | 0     | *0.576    | 9.2         | LOS A            | 8.8               | 64.8   | 0.24      | 0.22           | 0.24                | 24.5        |
| Approach                     |      |           | 1408         | 5.9   | 1408          | 5.9   | 0.576     | 3.1         | LOS A            | 14.7              | 108.2  | 0.28      | 0.26           | 0.28                | 42.8        |
| SouthWest: Hume St (SW)      |      |           |              |       |               |       |           |             |                  |                   |        |           |                |                     |             |
| 10                           | L2   | All MCs   | 93           | 0.0   | 93            | 0.0   | *0.396    | 64.6        | LOS E            | 5.7               | 40.2   | 0.96      | 0.78           | 0.96                | 4.4         |
| 12                           | R2   | All MCs   | 37           | 0.0   | 37            | 0.0   | 0.197     | 63.8        | LOS E            | 2.2               | 15.7   | 0.94      | 0.73           | 0.94                | 4.6         |
| Approach                     |      |           | 129          | 0.0   | 129           | 0.0   | 0.396     | 64.3        | LOS E            | 5.7               | 40.2   | 0.96      | 0.76           | 0.96                | 4.4         |
| All Vehicles                 |      |           | 2772         | 5.0   | 2772          | 5.0   | 0.576     | 4.9         | LOS A            | 14.7              | 108.2  | 0.20      | 0.19           | 0.20                | 39.7        |

Site Level of Service (LOS) Method: Delay (RTA NSW). Site LOS Method is specified in the Network Data dialog (Override Site Data tab).

Vehicle movement LOS values are based on average delay per movement.

Intersection and Approach LOS values are based on average delay for all vehicle movements.

Delay Model: SIDRA Standard (Control Delay: Geometric Delay is included).

Queue Model: SIDRA queue estimation methods are used for Back of Queue and Queue at Start of Green.

Gap-Acceptance Capacity Formula: SIDRA Standard (Akçelik M3D).

HV (%) values are calculated for All Movement Classes of All Heavy Vehicle Model Designation.

Arrival Flows used in performance calculations are adjusted to include any Initial Queued Demand and Upstream Capacity Constraint effects.

\* Critical Movement (Signal Timing)

| Pedestrian Movement Performance |          |           |             |                  |                       |        |           |                |             |              |             |
|---------------------------------|----------|-----------|-------------|------------------|-----------------------|--------|-----------|----------------|-------------|--------------|-------------|
| Mov ID                          | Crossing | Dem. Flow | Aver. Delay | Level of Service | AVERAGE BACK OF QUEUE |        | Prop. Que | Eff. Stop Rate | Travel Time | Travel Dist. | Aver. Speed |
|                                 |          | ped/h     | sec         |                  | [ Ped                 | Dist ] |           |                | sec         | m            | m/sec       |
|                                 |          |           |             |                  | ped                   | m      |           |                |             |              |             |
| SouthEast: Pacific Hwy (SE)     |          |           |             |                  |                       |        |           |                |             |              |             |
| P1                              | Full     | 23        | 55.2        | LOS E            | 0.1                   | 0.1    | 0.90      | 0.90           | 71.8        | 20.0         | 0.28        |
| NorthWest: Pacific Hwy (NW)     |          |           |             |                  |                       |        |           |                |             |              |             |
| P3                              | Full     | 1         | 55.1        | LOS E            | 0.0                   | 0.0    | 0.90      | 0.90           | 71.8        | 20.0         | 0.28        |
| SouthWest: Hume St (SW)         |          |           |             |                  |                       |        |           |                |             |              |             |
| P4                              | Full     | 101       | 58.1        | LOS E            | 0.4                   | 0.4    | 0.93      | 0.93           | 74.8        | 20.0         | 0.27        |
| All Pedestrians                 |          | 125       | 57.5        | LOS E            | 0.4                   | 0.4    | 0.92      | 0.92           | 74.2        | 20.0         | 0.27        |

Level of Service (LOS) Method: SIDRA Pedestrian LOS Method (Based on Average Delay)

Pedestrian movement LOS values are based on average delay per pedestrian movement.

Intersection LOS value for Pedestrians is based on average delay for all pedestrian movements.

**SIDRA INTERSECTION 9.1 | Copyright © 2000-2022 Akcelik and Associates Pty Ltd | sidrasolutions.com**

Organisation: AECOM AUSTRALIA PTY LTD | Licence: NETWORK / Enterprise Level 1 | Processed: Monday, 17 July 2023 1:41:23 PM

Project: C:\Users\YeungM\AECOM\ANZ-NAC-Sydney Metro-Sydney Metro C&SW Operational Monitoring - General\400\_Technical\432\_Traffic Analysis\SIDRA Modelling\01 Models (Geometry Only)\Block 1\Rev1\_Review\02 SM C&SW\_CST (Block 1)\_PS.sip9

# MOVEMENT SUMMARY

Site: CST04 [CST04 Pacific Hwy / Falcon St / Shirley Rd (Site Folder: Block 1 Model - 2023 AM Peak)]

Output produced by SIDRA INTERSECTION Version: 9.1.1.200

Network: CST-N1 [CST Network 1 (Network Folder: Block 1 Network - 2023 AM Peak)]

TCS 765

Site Category: (None)

Signals - EQUISAT (Fixed-Time/SCATS) Coordinated Cycle Time = 135 seconds (Network Site User-Given Phase Times)

| Vehicle Movement Performance |      |           |              |              |               |              |           |             |                  |                   |            |           |                |                     |             |
|------------------------------|------|-----------|--------------|--------------|---------------|--------------|-----------|-------------|------------------|-------------------|------------|-----------|----------------|---------------------|-------------|
| Mov ID                       | Turn | Mov Class | Demand Flows |              | Arrival Flows |              | Deg. Satn | Aver. Delay | Level of Service | 95% Back Of Queue |            | Prop. Que | Eff. Stop Rate | Aver. No. of Cycles | Aver. Speed |
|                              |      |           | [ Total HV ] | [ Total HV ] | [ Total HV ]  | [ Total HV ] |           |             |                  | [ Veh. veh        | [ Dist ] m |           |                |                     |             |
|                              |      |           | veh/h        | %            | veh/h         | %            | v/c       | sec         |                  |                   |            |           |                |                     | km/h        |
| SouthEast: Pacific Hwy (SE)  |      |           |              |              |               |              |           |             |                  |                   |            |           |                |                     |             |
| 1                            | L2   | All MCs   | 318          | 1.0          | 318           | 1.0          | 0.278     | 15.4        | LOS B            | 7.9               | 55.9       | 0.42      | 0.70           | 0.42                | 30.5        |
| 2                            | T1   | All MCs   | 757          | 4.6          | 757           | 4.6          | 0.537     | 32.1        | LOS C            | 19.1              | 138.9      | 0.80      | 0.70           | 0.80                | 12.3        |
| Approach                     |      |           | 1075         | 3.5          | 1075          | 3.5          | 0.537     | 27.1        | LOS B            | 19.1              | 138.9      | 0.68      | 0.70           | 0.68                | 17.7        |
| East: Falcon St (E)          |      |           |              |              |               |              |           |             |                  |                   |            |           |                |                     |             |
| 21b                          | L3   | All MCs   | 11           | 20.0         | 11            | 20.0         | 0.978     | 53.4        | LOS D            | 18.1              | 130.6      | 1.00      | 1.10           | 1.33                | 3.9         |
| 21a                          | L1   | All MCs   | 251          | 2.5          | 251           | 2.5          | *0.978    | 86.8        | LOS F            | 18.1              | 130.6      | 1.00      | 1.10           | 1.33                | 10.3        |
| 23a                          | R1   | All MCs   | 449          | 4.0          | 449           | 4.0          | 0.978     | 74.3        | LOS F            | 18.1              | 130.6      | 1.00      | 1.07           | 1.29                | 4.4         |
| Approach                     |      |           | 711          | 3.7          | 711           | 3.7          | 0.978     | 78.4        | LOS F            | 18.1              | 130.6      | 1.00      | 1.08           | 1.31                | 6.8         |
| North: Willoughby Rd (N)     |      |           |              |              |               |              |           |             |                  |                   |            |           |                |                     |             |
| 7                            | L2   | All MCs   | 34           | 12.5         | 34            | 12.5         | 0.027     | 3.8         | LOS A            | 0.1               | 1.1        | 0.07      | 0.48           | 0.07                | 37.0        |
| Approach                     |      |           | 34           | 12.5         | 34            | 12.5         | 0.027     | 3.8         | LOS A            | 0.1               | 1.1        | 0.07      | 0.48           | 0.07                | 37.0        |
| NorthWest: Pacific Hwy (NW)  |      |           |              |              |               |              |           |             |                  |                   |            |           |                |                     |             |
| 7a                           | L1   | All MCs   | 384          | 5.2          | 384           | 5.2          | 0.485     | 29.7        | LOS C            | 11.0              | 80.4       | 0.76      | 0.79           | 0.76                | 22.8        |
| 8                            | T1   | All MCs   | 1059         | 5.9          | 1059          | 5.9          | *0.805    | 34.8        | LOS C            | 31.9              | 234.3      | 0.88      | 0.80           | 0.90                | 16.9        |
| Approach                     |      |           | 1443         | 5.7          | 1443          | 5.7          | 0.805     | 33.5        | LOS C            | 31.9              | 234.3      | 0.85      | 0.80           | 0.87                | 18.1        |
| SouthWest: Shirley Rd (SW)   |      |           |              |              |               |              |           |             |                  |                   |            |           |                |                     |             |
| 10                           | L2   | All MCs   | 27           | 11.5         | 27            | 11.5         | *0.862    | 72.4        | LOS F            | 25.3              | 181.4      | 1.00      | 1.00           | 1.16                | 10.4        |
| 12a                          | R1   | All MCs   | 414          | 2.0          | 414           | 2.0          | 0.862     | 63.7        | LOS E            | 25.7              | 182.4      | 1.00      | 0.99           | 1.16                | 10.3        |
| 12                           | R2   | All MCs   | 288          | 1.5          | 288           | 1.5          | 0.862     | 65.9        | LOS E            | 25.7              | 182.4      | 1.00      | 0.97           | 1.16                | 10.0        |
| Approach                     |      |           | 729          | 2.2          | 729           | 2.2          | 0.862     | 64.9        | LOS E            | 25.7              | 182.4      | 1.00      | 0.98           | 1.16                | 10.2        |
| All Vehicles                 |      |           | 3992         | 4.2          | 3992          | 4.2          | 0.978     | 45.2        | LOS D            | 31.9              | 234.3      | 0.85      | 0.85           | 0.94                | 13.0        |

Site Level of Service (LOS) Method: Delay (RTA NSW). Site LOS Method is specified in the Network Data dialog (Override Site Data tab).

Vehicle movement LOS values are based on average delay per movement.

Intersection and Approach LOS values are based on average delay for all vehicle movements.

Delay Model: SIDRA Standard (Control Delay: Geometric Delay is included).

Queue Model: SIDRA queue estimation methods are used for Back of Queue and Queue at Start of Green.

Gap-Acceptance Capacity Formula: SIDRA Standard (Akçelik M3D).

HV (%) values are calculated for All Movement Classes of All Heavy Vehicle Model Designation.

Arrival Flows used in performance calculations are adjusted to include any Initial Queued Demand and Upstream Capacity Constraint effects.

\* Critical Movement (Signal Timing)

| Pedestrian Movement Performance |          |           |             |                  |                       |        |           |                |             |              |             |
|---------------------------------|----------|-----------|-------------|------------------|-----------------------|--------|-----------|----------------|-------------|--------------|-------------|
| Mov ID                          | Crossing | Dem. Flow | Aver. Delay | Level of Service | AVERAGE BACK OF QUEUE |        | Prop. Que | Eff. Stop Rate | Travel Time | Travel Dist. | Aver. Speed |
|                                 |          | ped/h     | sec         |                  | [ Ped                 | Dist ] |           |                | sec         | m            | m/sec       |
|                                 |          |           |             |                  | ped                   | m      |           |                |             |              |             |
| SouthEast: Pacific Hwy (SE)     |          |           |             |                  |                       |        |           |                |             |              |             |
| P1                              | Full     | 195       | 54.7        | LOS E            | 0.7                   | 0.7    | 0.90      | 0.90           | 71.3        | 20.0         | 0.28        |
| East: Falcon St (E)             |          |           |             |                  |                       |        |           |                |             |              |             |
| P5                              | Full     | 262       | 58.5        | LOS E            | 0.9                   | 0.9    | 0.94      | 0.94           | 75.2        | 20.0         | 0.27        |
| NorthWest: Pacific Hwy (NW)     |          |           |             |                  |                       |        |           |                |             |              |             |
| P3                              | Full     | 268       | 54.8        | LOS E            | 0.9                   | 0.9    | 0.91      | 0.91           | 71.5        | 20.0         | 0.28        |
| SouthWest: Shirley Rd (SW)      |          |           |             |                  |                       |        |           |                |             |              |             |
| P4                              | Full     | 196       | 58.3        | LOS E            | 0.7                   | 0.7    | 0.93      | 0.93           | 75.0        | 20.0         | 0.27        |
| All Pedestrians                 |          | 921       | 56.6        | LOS E            | 0.9                   | 0.9    | 0.92      | 0.92           | 73.3        | 20.0         | 0.27        |

Level of Service (LOS) Method: SIDRA Pedestrian LOS Method (Based on Average Delay)

Pedestrian movement LOS values are based on average delay per pedestrian movement.

Intersection LOS value for Pedestrians is based on average delay for all pedestrian movements.

**SIDRA INTERSECTION 9.1 | Copyright © 2000-2022 Akcelik and Associates Pty Ltd | sidrasolutions.com**

Organisation: AECOM AUSTRALIA PTY LTD | Licence: NETWORK / Enterprise Level 1 | Processed: Monday, 17 July 2023 1:41:23 PM

Project: C:\Users\YeungMAECOMANZ-NAC-Sydney Metro-Sydney Metro C&SW Operational Monitoring - General\400\_Technical\432\_Traffic Analysis\SIDRA Modelling\01 Models (Geometry Only)\Block 1\Rev1\_Review\02 SM C&SW\_CST (Block 1)\_PS.sip9

# MOVEMENT SUMMARY

Site: CST05 [CST05 Clarke St / Oxley St (Site Folder: Block 1 Model - 2023 AM Peak)]

Output produced by SIDRA INTERSECTION Version: 9.1.1.200

Network: CST-N1 [CST Network 1 (Network Folder: Block 1 Network - 2023 AM Peak)]

NA  
 Site Category: (None)  
 Give-Way (Two-Way)

| Vehicle Movement Performance |      |           |                       |     |                       |     |           |             |                  |                   |               |           |                |                     |                  |
|------------------------------|------|-----------|-----------------------|-----|-----------------------|-----|-----------|-------------|------------------|-------------------|---------------|-----------|----------------|---------------------|------------------|
| Mov ID                       | Turn | Mov Class | Demand Flows          |     | Arrival Flows         |     | Deg. Satn | Aver. Delay | Level of Service | 95% Back Of Queue |               | Prop. Que | Eff. Stop Rate | Aver. No. of Cycles | Aver. Speed km/h |
|                              |      |           | [ Total HV ]<br>veh/h | %   | [ Total HV ]<br>veh/h | %   |           |             |                  | [ Veh. veh        | [ Dist ]<br>m |           |                |                     |                  |
| SouthEast: Clarke St (SE)    |      |           |                       |     |                       |     |           |             |                  |                   |               |           |                |                     |                  |
| 1                            | L2   | All MCs   | 31                    | 3.4 | 31                    | 3.4 | 0.079     | 5.3         | LOS A            | 0.3               | 1.9           | 0.38      | 0.59           | 0.38                | 31.9             |
| 3a                           | R1   | All MCs   | 42                    | 2.5 | 42                    | 2.5 | 0.079     | 6.3         | LOS A            | 0.3               | 1.9           | 0.38      | 0.59           | 0.38                | 31.9             |
| Approach                     |      |           | 73                    | 2.9 | 73                    | 2.9 | 0.079     | 5.9         | LOS A            | 0.3               | 1.9           | 0.38      | 0.59           | 0.38                | 31.9             |
| North: Oxley St (N)          |      |           |                       |     |                       |     |           |             |                  |                   |               |           |                |                     |                  |
| 24a                          | L1   | All MCs   | 97                    | 1.1 | 97                    | 1.1 | 0.173     | 4.4         | LOS A            | 0.0               | 0.0           | 0.00      | 0.53           | 0.00                | 29.7             |
| 26a                          | R1   | All MCs   | 206                   | 2.0 | 206                   | 2.0 | 0.173     | 4.1         | LOS A            | 0.0               | 0.0           | 0.00      | 0.53           | 0.00                | 29.7             |
| Approach                     |      |           | 303                   | 1.7 | 303                   | 1.7 | 0.173     | 4.2         | NA               | 0.0               | 0.0           | 0.00      | 0.53           | 0.00                | 29.7             |
| SouthWest: Oxley St (SW)     |      |           |                       |     |                       |     |           |             |                  |                   |               |           |                |                     |                  |
| 10a                          | L1   | All MCs   | 148                   | 0.0 | 148                   | 0.0 | 0.137     | 2.8         | LOS A            | 0.5               | 3.9           | 0.29      | 0.56           | 0.29                | 22.2             |
| 12                           | R2   | All MCs   | 77                    | 2.7 | 77                    | 2.7 | 0.137     | 5.3         | LOS A            | 0.5               | 3.9           | 0.29      | 0.56           | 0.29                | 22.2             |
| Approach                     |      |           | 225                   | 0.9 | 225                   | 0.9 | 0.137     | 3.6         | NA               | 0.5               | 3.9           | 0.29      | 0.56           | 0.29                | 22.2             |
| All Vehicles                 |      |           | 601                   | 1.6 | 601                   | 1.6 | 0.173     | 4.2         | NA               | 0.5               | 3.9           | 0.15      | 0.55           | 0.15                | 28.2             |

Site Level of Service (LOS) Method: Delay (RTA NSW). Site LOS Method is specified in the Network Data dialog (Override Site Data tab).

Vehicle movement LOS values are based on average delay per movement.

Minor Road Approach LOS values are based on average delay for all vehicle movements.

NA (TWSC): Level of Service is not defined for major road approaches or the intersection as a whole for Two-Way Sign Control (HCM LOS rule).

Two-Way Sign Control Capacity Model: SIDRA Standard.

Delay Model: SIDRA Standard (Control Delay: Geometric Delay is included).

Queue Model: SIDRA queue estimation methods are used for Back of Queue and Queue at Start of Gap.

Gap-Acceptance Capacity Formula: SIDRA Standard (Akçelik M3D).

HV (%) values are calculated for All Movement Classes of All Heavy Vehicle Model Designation.

Arrival Flows used in performance calculations are adjusted to include any Initial Queued Demand and Upstream Capacity Constraint effects.

---

**SIDRA INTERSECTION 9.1 | Copyright © 2000-2022 Akcelik and Associates Pty Ltd | sidrasolutions.com**

Organisation: AECOM AUSTRALIA PTY LTD | Licence: NETWORK / Enterprise Level 1 | Processed: Monday, 17 July 2023 1:41:23 PM

Project: C:\Users\Yeung\AECOM\ANZ-NAC-Sydney Metro-Sydney Metro C&SW Operational Monitoring - General\400\_Technical\432\_Traffic Analysis\SIDRA Modelling\01 Models (Geometry Only)\Block 1\Rev1\\_Review\02 SM C&SW\_CST (Block 1)\_PS.sip9

# MOVEMENT SUMMARY

Site: CST06 [CST06 Clarke St / Hume St (Site Folder: Block 1 Model - 2023 AM Peak)]

Output produced by SIDRA INTERSECTION Version: 9.1.1.200

Network: CST-N1 [CST Network 1 (Network Folder: Block 1 Network - 2023 AM Peak)]

NA  
 Site Category: (None)  
 Give-Way (Two-Way)

| Vehicle Movement Performance |      |           |                       |     |                       |     |           |             |                  |                   |               |           |                |                     |                  |
|------------------------------|------|-----------|-----------------------|-----|-----------------------|-----|-----------|-------------|------------------|-------------------|---------------|-----------|----------------|---------------------|------------------|
| Mov ID                       | Turn | Mov Class | Demand Flows          |     | Arrival Flows         |     | Deg. Satn | Aver. Delay | Level of Service | 95% Back Of Queue |               | Prop. Que | Eff. Stop Rate | Aver. No. of Cycles | Aver. Speed km/h |
|                              |      |           | [ Total HV ]<br>veh/h | %   | [ Total HV ]<br>veh/h | %   |           |             |                  | [ Veh. veh        | [ Dist ]<br>m |           |                |                     |                  |
| SouthEast: Clarke St (SE)    |      |           |                       |     |                       |     |           |             |                  |                   |               |           |                |                     |                  |
| 1                            | L2   | All MCs   | 7                     | 0.0 | 7                     | 0.0 | 0.033     | 4.6         | LOS A            | 0.0               | 0.0           | 0.00      | 0.05           | 0.00                | 47.5             |
| 2                            | T1   | All MCs   | 77                    | 2.7 | 77                    | 2.7 | 0.033     | 0.0         | LOS A            | 0.0               | 0.0           | 0.00      | 0.05           | 0.00                | 47.5             |
| Approach                     |      |           | 84                    | 2.5 | 84                    | 2.5 | 0.033     | 0.4         | NA               | 0.0               | 0.0           | 0.00      | 0.05           | 0.00                | 47.5             |
| NorthWest: Clarke St (NW)    |      |           |                       |     |                       |     |           |             |                  |                   |               |           |                |                     |                  |
| 8                            | T1   | All MCs   | 151                   | 2.1 | 151                   | 2.1 | 0.052     | 0.0         | LOS A            | 0.1               | 0.6           | 0.04      | 0.05           | 0.04                | 48.5             |
| 9                            | R2   | All MCs   | 14                    | 0.0 | 14                    | 0.0 | 0.052     | 4.9         | LOS A            | 0.1               | 0.6           | 0.04      | 0.05           | 0.04                | 47.5             |
| Approach                     |      |           | 164                   | 1.9 | 164                   | 1.9 | 0.052     | 0.4         | NA               | 0.1               | 0.6           | 0.04      | 0.05           | 0.04                | 48.4             |
| SouthWest: Hume St (SW)      |      |           |                       |     |                       |     |           |             |                  |                   |               |           |                |                     |                  |
| 10                           | L2   | All MCs   | 3                     | 0.0 | 3                     | 0.0 | 0.008     | 3.4         | LOS A            | 0.0               | 0.1           | 0.19      | 0.48           | 0.19                | 24.1             |
| 12                           | R2   | All MCs   | 2                     | 0.0 | 2                     | 0.0 | 0.008     | 3.9         | LOS A            | 0.0               | 0.1           | 0.19      | 0.48           | 0.19                | 32.1             |
| Approach                     |      |           | 5                     | 0.0 | 5                     | 0.0 | 0.008     | 3.6         | LOS A            | 0.0               | 0.1           | 0.19      | 0.48           | 0.19                | 29.0             |
| All Vehicles                 |      |           | 254                   | 2.1 | 254                   | 2.1 | 0.052     | 0.5         | NA               | 0.1               | 0.6           | 0.03      | 0.06           | 0.03                | 48.0             |

Site Level of Service (LOS) Method: Delay (RTA NSW). Site LOS Method is specified in the Network Data dialog (Override Site Data tab).

Vehicle movement LOS values are based on average delay per movement.

Minor Road Approach LOS values are based on average delay for all vehicle movements.

NA (TWSC): Level of Service is not defined for major road approaches or the intersection as a whole for Two-Way Sign Control (HCM LOS rule).

Two-Way Sign Control Capacity Model: SIDRA Standard.

Delay Model: SIDRA Standard (Control Delay: Geometric Delay is included).

Queue Model: SIDRA queue estimation methods are used for Back of Queue and Queue at Start of Gap.

Gap-Acceptance Capacity Formula: SIDRA Standard (Akçelik M3D).

HV (%) values are calculated for All Movement Classes of All Heavy Vehicle Model Designation.

Arrival Flows used in performance calculations are adjusted to include any Initial Queued Demand and Upstream Capacity Constraint effects.



---

**SIDRA INTERSECTION 9.1 | Copyright © 2000-2022 Akcelik and Associates Pty Ltd | sidrasolutions.com**

Organisation: AECOM AUSTRALIA PTY LTD | Licence: NETWORK / Enterprise Level 1 | Processed: Monday, 17 July 2023 1:41:23 PM

Project: C:\Users\Yeung\AECOM\ANZ-NAC-Sydney Metro-Sydney Metro C&SW Operational Monitoring - General\400\_Technical\432\_Traffic Analysis\SIDRA Modelling\01 Models (Geometry Only)\Block 1\Rev1\\_Review\02 SM C&SW\_CST (Block 1)\_PS.sip9

# MOVEMENT SUMMARY

Site: CST07 [CST07 Clarke St / Willoughby Rd (Site Folder: Block 1 Model - 2023 AM Peak)]

Output produced by SIDRA INTERSECTION Version: 9.1.1.200

NA

Site Category: (None)

Give-Way (Two-Way)

| Vehicle Movement Performance |      |           |              |      |               |      |           |             |                  |                   |          |           |                |                     |             |
|------------------------------|------|-----------|--------------|------|---------------|------|-----------|-------------|------------------|-------------------|----------|-----------|----------------|---------------------|-------------|
| Mov ID                       | Turn | Mov Class | Demand Flows |      | Arrival Flows |      | Deg. Satn | Aver. Delay | Level of Service | 95% Back Of Queue |          | Prop. Que | Eff. Stop Rate | Aver. No. of Cycles | Aver. Speed |
|                              |      |           | [ Total HV ] | %    | [ Total HV ]  | %    | v/c       | sec         |                  | [ Veh. ]          | [ Dist ] |           |                |                     | km/h        |
|                              |      |           | veh/h        |      | veh/h         |      |           |             |                  | veh               | m        |           |                |                     |             |
| South: Willoughby Rd (S)     |      |           |              |      |               |      |           |             |                  |                   |          |           |                |                     |             |
| 1                            | L2   | All MCs   | 107          | 2.0  | 107           | 2.0  | 0.264     | 3.8         | LOS A            | 1.4               | 10.7     | 0.30      | 0.27           | 0.30                | 32.0        |
| 2                            | T1   | All MCs   | 174          | 15.2 | 174           | 15.2 | 0.264     | 1.1         | LOS A            | 1.4               | 10.7     | 0.30      | 0.27           | 0.30                | 36.5        |
| Approach                     |      |           | 281          | 10.1 | 281           | 10.1 | 0.264     | 2.2         | NA               | 1.4               | 10.7     | 0.30      | 0.27           | 0.30                | 35.2        |
| North: Willoughby Rd (N)     |      |           |              |      |               |      |           |             |                  |                   |          |           |                |                     |             |
| 8                            | T1   | All MCs   | 154          | 11.6 | 154           | 11.6 | 0.206     | 1.0         | LOS A            | 0.9               | 7.0      | 0.30      | 0.25           | 0.30                | 36.8        |
| 9                            | R2   | All MCs   | 46           | 6.8  | 46            | 6.8  | 0.206     | 6.6         | LOS A            | 0.9               | 7.0      | 0.30      | 0.25           | 0.30                | 35.7        |
| Approach                     |      |           | 200          | 10.5 | 200           | 10.5 | 0.206     | 2.3         | NA               | 0.9               | 7.0      | 0.30      | 0.25           | 0.30                | 36.5        |
| West: Clarke St (W)          |      |           |              |      |               |      |           |             |                  |                   |          |           |                |                     |             |
| 10                           | L2   | All MCs   | 49           | 2.1  | 49            | 2.1  | 0.134     | 4.9         | LOS A            | 0.5               | 3.5      | 0.46      | 0.65           | 0.46                | 32.9        |
| 12                           | R2   | All MCs   | 68           | 4.6  | 68            | 4.6  | 0.134     | 6.2         | LOS A            | 0.5               | 3.5      | 0.46      | 0.65           | 0.46                | 26.9        |
| Approach                     |      |           | 118          | 3.6  | 118           | 3.6  | 0.134     | 5.7         | LOS A            | 0.5               | 3.5      | 0.46      | 0.65           | 0.46                | 30.3        |
| All Vehicles                 |      |           | 599          | 9.0  | 599           | 9.0  | 0.264     | 2.9         | NA               | 1.4               | 10.7     | 0.33      | 0.34           | 0.33                | 34.7        |

Site Level of Service (LOS) Method: Delay (RTA NSW). Site LOS Method is specified in the Parameter Settings dialog (Options tab).

Vehicle movement LOS values are based on average delay per movement.

Minor Road Approach LOS values are based on average delay for all vehicle movements.

NA (TWSC): Level of Service is not defined for major road approaches or the intersection as a whole for Two-Way Sign Control (HCM LOS rule).

Two-Way Sign Control Capacity Model: SIDRA Standard.

Delay Model: SIDRA Standard (Control Delay: Geometric Delay is included).

Queue Model: SIDRA queue estimation methods are used for Back of Queue and Queue at Start of Gap.

Gap-Acceptance Capacity Formula: SIDRA Standard (Akçelik M3D).

HV (%) values are calculated for All Movement Classes of All Heavy Vehicle Model Designation.

Arrival Flows used in performance calculations are adjusted to include any Initial Queued Demand and Upstream Capacity Constraint effects.

---

**SIDRA INTERSECTION 9.1 | Copyright © 2000-2022 Akcelik and Associates Pty Ltd | sidrasolutions.com**

Organisation: AECOM AUSTRALIA PTY LTD | Licence: NETWORK / Enterprise Level 1 | Processed: Thursday, 13 July 2023 6:24:24 PM

Project: C:\Users\Yeung\AECOM\ANZ-NAC-Sydney Metro-Sydney Metro C&SW Operational Monitoring - General\400\_Technical\432\_Traffic Analysis\SIDRA Modelling\01 Models (Geometry Only)\Block 1\Rev1\\_Review\02 SM C&SW\_CST (Block 1)\_PS.sip9

# MOVEMENT SUMMARY

**Site: CST08 [CST08 Albany St / Willoughby Rd (Site Folder: Block 1 Model - 2023 AM Peak)]**

**Output produced by SIDRA INTERSECTION Version: 9.1.1.200**

TCS 516

Site Category: (None)

Signals - EQUISAT (Fixed-Time/SCATS) Isolated Cycle Time = 80 seconds (Site User-Given Phase Times)

| Vehicle Movement Performance |      |           |              |      |               |      |           |             |                  |                   |          |           |                |                     |             |
|------------------------------|------|-----------|--------------|------|---------------|------|-----------|-------------|------------------|-------------------|----------|-----------|----------------|---------------------|-------------|
| Mov ID                       | Turn | Mov Class | Demand Flows |      | Arrival Flows |      | Deg. Satn | Aver. Delay | Level of Service | 95% Back Of Queue |          | Prop. Que | Eff. Stop Rate | Aver. No. of Cycles | Aver. Speed |
|                              |      |           | [ Total HV ] | %    | [ Total HV ]  | %    | v/c       | sec         |                  | [ Veh. ]          | [ Dist ] |           |                |                     | km/h        |
|                              |      |           | veh/h        |      | veh/h         |      |           |             |                  | veh               | m        |           |                |                     |             |
| South: Willoughby Rd (S)     |      |           |              |      |               |      |           |             |                  |                   |          |           |                |                     |             |
| 1                            | L2   | All MCs   | 78           | 10.8 | 78            | 10.8 | 0.139     | 32.9        | LOS C            | 2.1               | 16.3     | 0.73      | 0.70           | 0.73                | 24.4        |
| 2                            | T1   | All MCs   | 165          | 8.3  | 165           | 8.3  | 0.343     | 30.3        | LOS C            | 4.9               | 37.1     | 0.77      | 0.66           | 0.77                | 27.5        |
| 3                            | R2   | All MCs   | 6            | 33.3 | 6             | 33.3 | 0.343     | 38.9        | LOS C            | 4.9               | 37.1     | 0.77      | 0.66           | 0.77                | 25.8        |
| Approach                     |      |           | 249          | 9.7  | 249           | 9.7  | 0.343     | 31.4        | LOS C            | 4.9               | 37.1     | 0.76      | 0.67           | 0.76                | 26.4        |
| East: Albany St (E)          |      |           |              |      |               |      |           |             |                  |                   |          |           |                |                     |             |
| 4                            | L2   | All MCs   | 9            | 11.1 | 9             | 11.1 | 0.240     | 16.3        | LOS B            | 5.0               | 36.1     | 0.58      | 0.50           | 0.58                | 31.6        |
| 5                            | T1   | All MCs   | 351          | 2.4  | 351           | 2.4  | 0.481     | 12.2        | LOS A            | 7.2               | 51.4     | 0.66      | 0.58           | 0.66                | 30.7        |
| 6                            | R2   | All MCs   | 137          | 0.8  | 137           | 0.8  | *0.481    | 25.7        | LOS B            | 7.2               | 51.4     | 0.80      | 0.73           | 0.80                | 26.2        |
| Approach                     |      |           | 497          | 2.1  | 497           | 2.1  | 0.481     | 16.0        | LOS B            | 7.2               | 51.4     | 0.70      | 0.62           | 0.70                | 29.3        |
| North: Willoughby Rd (N)     |      |           |              |      |               |      |           |             |                  |                   |          |           |                |                     |             |
| 7                            | L2   | All MCs   | 122          | 1.7  | 122           | 1.7  | 0.153     | 19.2        | LOS B            | 2.9               | 20.3     | 0.64      | 0.71           | 0.64                | 26.7        |
| 8                            | T1   | All MCs   | 162          | 5.2  | 162           | 5.2  | *0.373    | 22.3        | LOS B            | 6.2               | 44.9     | 0.80      | 0.73           | 0.80                | 25.7        |
| 9                            | R2   | All MCs   | 43           | 2.4  | 43            | 2.4  | 0.373     | 30.8        | LOS C            | 6.2               | 44.9     | 0.80      | 0.73           | 0.80                | 24.2        |
| Approach                     |      |           | 327          | 3.5  | 327           | 3.5  | 0.373     | 22.3        | LOS B            | 6.2               | 44.9     | 0.74      | 0.72           | 0.74                | 25.8        |
| West: Albany St (W)          |      |           |              |      |               |      |           |             |                  |                   |          |           |                |                     |             |
| 10                           | L2   | All MCs   | 92           | 2.3  | 92            | 2.3  | 0.130     | 21.6        | LOS B            | 2.3               | 16.4     | 0.68      | 0.71           | 0.68                | 25.4        |
| 11                           | T1   | All MCs   | 314          | 2.7  | 314           | 2.7  | *0.400    | 17.9        | LOS B            | 8.6               | 61.9     | 0.75      | 0.64           | 0.75                | 28.0        |
| Approach                     |      |           | 405          | 2.6  | 405           | 2.6  | 0.400     | 18.7        | LOS B            | 8.6               | 61.9     | 0.73      | 0.66           | 0.73                | 27.4        |
| All Vehicles                 |      |           | 1479         | 3.8  | 1479          | 3.8  | 0.481     | 20.7        | LOS B            | 8.6               | 61.9     | 0.73      | 0.66           | 0.73                | 27.3        |

Site Level of Service (LOS) Method: Delay (RTA NSW). Site LOS Method is specified in the Parameter Settings dialog (Options tab).

Vehicle movement LOS values are based on average delay per movement.

Intersection and Approach LOS values are based on average delay for all vehicle movements.

Delay Model: SIDRA Standard (Control Delay: Geometric Delay is included).

Queue Model: SIDRA queue estimation methods are used for Back of Queue and Queue at Start of Green.

Gap-Acceptance Capacity Formula: SIDRA Standard (Akçelik M3D).

HV (%) values are calculated for All Movement Classes of All Heavy Vehicle Model Designation.

Arrival Flows used in performance calculations are adjusted to include any Initial Queued Demand and Upstream Capacity Constraint effects.

\* Critical Movement (Signal Timing)

| Pedestrian Movement Performance |          |            |           |             |                  |                       |        |           |                |             |              |             |
|---------------------------------|----------|------------|-----------|-------------|------------------|-----------------------|--------|-----------|----------------|-------------|--------------|-------------|
| Mov ID                          | Crossing | Input Vol. | Dem. Flow | Aver. Delay | Level of Service | AVERAGE BACK OF QUEUE |        | Prop. Que | Eff. Stop Rate | Travel Time | Travel Dist. | Aver. Speed |
|                                 |          | ped/h      | ped/h     | sec         |                  | [ Ped                 | Dist ] |           |                | sec         | m            | m/sec       |
|                                 |          |            |           |             |                  | ped                   | m      |           |                |             |              |             |
| South: Willoughby Rd (S)        |          |            |           |             |                  |                       |        |           |                |             |              |             |
| P1                              | Full     | 33         | 35        | 29.8        | LOS C            | 0.1                   | 0.1    | 0.86      | 0.86           | 46.5        | 20.0         | 0.43        |
| East: Albany St (E)             |          |            |           |             |                  |                       |        |           |                |             |              |             |
| P2                              | Full     | 103        | 108       | 29.9        | LOS C            | 0.2                   | 0.2    | 0.87      | 0.87           | 46.6        | 20.0         | 0.43        |
| North: Willoughby Rd (N)        |          |            |           |             |                  |                       |        |           |                |             |              |             |
| P3                              | Full     | 48         | 51        | 29.8        | LOS C            | 0.1                   | 0.1    | 0.86      | 0.86           | 46.5        | 20.0         | 0.43        |
| West: Albany St (W)             |          |            |           |             |                  |                       |        |           |                |             |              |             |
| P4                              | Full     | 55         | 58        | 29.8        | LOS C            | 0.1                   | 0.1    | 0.86      | 0.86           | 46.5        | 20.0         | 0.43        |
| All Pedestrians                 |          | 239        | 252       | 29.8        | LOS C            | 0.2                   | 0.2    | 0.87      | 0.87           | 46.5        | 20.0         | 0.43        |

Level of Service (LOS) Method: SIDRA Pedestrian LOS Method (Based on Average Delay)

Pedestrian movement LOS values are based on average delay per pedestrian movement.

Intersection LOS value for Pedestrians is based on average delay for all pedestrian movements.

**SIDRA INTERSECTION 9.1 | Copyright © 2000-2022 Kcelik and Associates Pty Ltd | sidrasolutions.com**

Organisation: AECOM AUSTRALIA PTY LTD | Licence: NETWORK / Enterprise Level 1 | Processed: Thursday, 13 July 2023 6:24:25 PM

Project: C:\Users\YeungM\AECOM\ANZ-NAC-Sydney Metro-Sydney Metro C&SW Operational Monitoring - General\400\_Technical\432\_Traffic Analysis\SIDRA Modelling\01 Models (Geometry Only)\Block 1\Rev1\\_Review\02 SM C&SW\_CST (Block 1)\_PS.sip9

# MOVEMENT SUMMARY

Site: CST09 [CST09 Albany St / Oxley St (Site Folder: Block 1 Model - 2023 AM Peak)]

Output produced by SIDRA INTERSECTION Version: 9.1.1.200

Network: CST-N1 [CST Network 1 (Network Folder: Block 1 Network - 2023 AM Peak)]

NA  
Site Category: (None)  
Roundabout

| Vehicle Movement Performance |      |           |                       |     |                       |     |           |             |                  |                   |               |           |                |                     |                  |
|------------------------------|------|-----------|-----------------------|-----|-----------------------|-----|-----------|-------------|------------------|-------------------|---------------|-----------|----------------|---------------------|------------------|
| Mov ID                       | Turn | Mov Class | Demand Flows          |     | Arrival Flows         |     | Deg. Satn | Aver. Delay | Level of Service | 95% Back Of Queue |               | Prop. Que | Eff. Stop Rate | Aver. No. of Cycles | Aver. Speed km/h |
|                              |      |           | [ Total HV ]<br>veh/h | %   | [ Total HV ]<br>veh/h | %   |           |             |                  | [ Veh. veh        | [ Dist ]<br>m |           |                |                     |                  |
| South: Oxley St (S)          |      |           |                       |     |                       |     |           |             |                  |                   |               |           |                |                     |                  |
| 1                            | L2   | All MCs   | 35                    | 0.0 | 35                    | 0.0 | 0.302     | 8.4         | LOS A            | 2.0               | 14.1          | 0.77      | 0.68           | 0.77                | 21.0             |
| 2                            | T1   | All MCs   | 96                    | 1.1 | 96                    | 1.1 | 0.302     | 8.3         | LOS A            | 2.0               | 14.1          | 0.77      | 0.68           | 0.77                | 32.2             |
| 3                            | R2   | All MCs   | 68                    | 0.0 | 68                    | 0.0 | 0.302     | 11.1        | LOS A            | 2.0               | 14.1          | 0.77      | 0.68           | 0.77                | 30.4             |
| 3u                           | U    | All MCs   | 3                     | 0.0 | 3                     | 0.0 | 0.302     | 12.5        | LOS A            | 2.0               | 14.1          | 0.77      | 0.68           | 0.77                | 21.0             |
| Approach                     |      |           | 202                   | 0.5 | 202                   | 0.5 | 0.302     | 9.3         | LOS A            | 2.0               | 14.1          | 0.77      | 0.68           | 0.77                | 30.3             |
| East: Albany St (E)          |      |           |                       |     |                       |     |           |             |                  |                   |               |           |                |                     |                  |
| 4                            | L2   | All MCs   | 47                    | 2.2 | 47                    | 2.2 | 0.677     | 10.3        | LOS A            | 5.7               | 41.1          | 0.71      | 0.83           | 0.87                | 27.3             |
| 5                            | T1   | All MCs   | 383                   | 2.7 | 383                   | 2.7 | 0.677     | 10.1        | LOS A            | 5.7               | 41.1          | 0.71      | 0.83           | 0.87                | 27.3             |
| 6                            | R2   | All MCs   | 41                    | 0.0 | 41                    | 0.0 | 0.677     | 12.8        | LOS A            | 5.7               | 41.1          | 0.71      | 0.83           | 0.87                | 33.3             |
| 6u                           | U    | All MCs   | 4                     | 0.0 | 4                     | 0.0 | 0.677     | 14.2        | LOS A            | 5.7               | 41.1          | 0.71      | 0.83           | 0.87                | 32.6             |
| Approach                     |      |           | 476                   | 2.4 | 476                   | 2.4 | 0.677     | 10.4        | LOS A            | 5.7               | 41.1          | 0.71      | 0.83           | 0.87                | 28.2             |
| North: Oxley St (N)          |      |           |                       |     |                       |     |           |             |                  |                   |               |           |                |                     |                  |
| 7                            | L2   | All MCs   | 47                    | 0.0 | 47                    | 0.0 | 0.460     | 10.2        | LOS A            | 3.4               | 23.9          | 0.86      | 0.78           | 0.94                | 33.1             |
| 8                            | T1   | All MCs   | 153                   | 2.1 | 153                   | 2.1 | 0.460     | 10.1        | LOS A            | 3.4               | 23.9          | 0.86      | 0.78           | 0.94                | 28.0             |
| 9                            | R2   | All MCs   | 80                    | 1.3 | 80                    | 1.3 | 0.460     | 12.9        | LOS A            | 3.4               | 23.9          | 0.86      | 0.78           | 0.94                | 28.0             |
| 9u                           | U    | All MCs   | 1                     | 0.0 | 1                     | 0.0 | 0.460     | 14.2        | LOS A            | 3.4               | 23.9          | 0.86      | 0.78           | 0.94                | 33.4             |
| Approach                     |      |           | 281                   | 1.5 | 281                   | 1.5 | 0.460     | 10.9        | LOS A            | 3.4               | 23.9          | 0.86      | 0.78           | 0.94                | 29.3             |
| West: Albany St (W)          |      |           |                       |     |                       |     |           |             |                  |                   |               |           |                |                     |                  |
| 10                           | L2   | All MCs   | 113                   | 1.9 | 113                   | 1.9 | 0.618     | 6.7         | LOS A            | 6.0               | 42.7          | 0.75      | 0.59           | 0.77                | 34.3             |
| 11                           | T1   | All MCs   | 374                   | 2.5 | 374                   | 2.5 | 0.618     | 6.5         | LOS A            | 6.0               | 42.7          | 0.75      | 0.59           | 0.77                | 34.1             |
| 12                           | R2   | All MCs   | 100                   | 2.1 | 100                   | 2.1 | 0.618     | 9.4         | LOS A            | 6.0               | 42.7          | 0.75      | 0.59           | 0.77                | 25.8             |
| 12u                          | U    | All MCs   | 11                    | 0.0 | 11                    | 0.0 | 0.618     | 10.7        | LOS A            | 6.0               | 42.7          | 0.75      | 0.59           | 0.77                | 25.8             |
| Approach                     |      |           | 597                   | 2.3 | 597                   | 2.3 | 0.618     | 7.1         | LOS A            | 6.0               | 42.7          | 0.75      | 0.59           | 0.77                | 33.2             |
| All Vehicles                 |      |           | 1556                  | 2.0 | 1556                  | 2.0 | 0.677     | 9.1         | LOS A            | 6.0               | 42.7          | 0.76      | 0.71           | 0.83                | 30.6             |

Site Level of Service (LOS) Method: Delay (RTA NSW). Site LOS Method is specified in the Network Data dialog (Override Site Data tab).

Vehicle movement LOS values are based on average delay per movement.

Intersection and Approach LOS values are based on average delay for all vehicle movements.

Roundabout Capacity Model: SIDRA Standard.

Delay Model: SIDRA Standard (Control Delay: Geometric Delay is included).

Queue Model: SIDRA queue estimation methods are used for Back of Queue and Queue at Start of Gap.

Gap-Acceptance Capacity Formula: SIDRA Standard (Akçelik M3D).

HV (%) values are calculated for All Movement Classes of All Heavy Vehicle Model Designation.

Arrival Flows used in performance calculations are adjusted to include any Initial Queued Demand and Upstream Capacity Constraint effects.

---

**SIDRA INTERSECTION 9.1 | Copyright © 2000-2022 Akcelik and Associates Pty Ltd | sidrasolutions.com**

Organisation: AECOM AUSTRALIA PTY LTD | Licence: NETWORK / Enterprise Level 1 | Processed: Monday, 17 July 2023 1:41:23 PM

Project: C:\Users\Yeung\AECOM\ANZ-NAC-Sydney Metro-Sydney Metro C&SW Operational Monitoring - General\400\_Technical\432\_Traffic Analysis\SIDRA Modelling\01 Models (Geometry Only)\Block 1\Rev1\\_Review\02 SM C&SW\_CST (Block 1)\_PS.sip9



# MOVEMENT SUMMARY

Site: CST10 [CST10 Albany St / Clarke Ln (Site Folder: Block 1 Model - 2023 AM Peak)]

Output produced by SIDRA INTERSECTION Version: 9.1.1.200

Network: CST-N1 [CST Network 1 (Network Folder: Block 1 Network - 2023 AM Peak)]

NA

Site Category: (None)

Give-Way (Two-Way)

| Vehicle Movement Performance |      |           |                       |     |                       |     |           |             |                  |                   |               |           |                |                     |                  |
|------------------------------|------|-----------|-----------------------|-----|-----------------------|-----|-----------|-------------|------------------|-------------------|---------------|-----------|----------------|---------------------|------------------|
| Mov ID                       | Turn | Mov Class | Demand Flows          |     | Arrival Flows         |     | Deg. Satn | Aver. Delay | Level of Service | 95% Back Of Queue |               | Prop. Que | Eff. Stop Rate | Aver. No. of Cycles | Aver. Speed km/h |
|                              |      |           | [ Total HV ]<br>veh/h | %   | [ Total HV ]<br>veh/h | %   |           |             |                  | [ Veh. veh        | [ Dist ]<br>m |           |                |                     |                  |
| SouthEast: Clarke Ln (SE)    |      |           |                       |     |                       |     |           |             |                  |                   |               |           |                |                     |                  |
| 21a                          | L1   | All MCs   | 32                    | 0.0 | 32                    | 0.0 | 0.067     | 4.2         | LOS A            | 7.5               | 54.0          | 0.18      | 0.49           | 0.18                | 31.2             |
| 23b                          | R3   | All MCs   | 250.0                 |     | 250.0                 |     | 0.067     | 31.9        | LOS C            | 7.5               | 54.0          | 0.18      | 0.49           | 0.18                | 31.2             |
| Approach                     |      |           | 34                    | 3.1 | 34                    | 3.1 | 0.067     | 5.9         | LOS A            | 7.5               | 54.0          | 0.18      | 0.49           | 0.18                | 31.2             |
| East: Albany St (E)          |      |           |                       |     |                       |     |           |             |                  |                   |               |           |                |                     |                  |
| 5                            | T1   | All MCs   | 508                   | 2.3 | 508                   | 2.3 | 0.242     | 0.0         | LOS A            | 13.4              | 95.9          | 0.00      | 0.00           | 0.00                | 49.9             |
| Approach                     |      |           | 508                   | 2.3 | 508                   | 2.3 | 0.242     | 0.0         | NA               | 13.4              | 95.9          | 0.00      | 0.00           | 0.00                | 49.9             |
| West: Albany St (W)          |      |           |                       |     |                       |     |           |             |                  |                   |               |           |                |                     |                  |
| 11                           | T1   | All MCs   | 565                   | 2.4 | 565                   | 2.4 | 0.297     | 0.0         | LOS A            | 0.0               | 0.0           | 0.00      | 0.00           | 0.00                | 49.9             |
| Approach                     |      |           | 565                   | 2.4 | 565                   | 2.4 | 0.297     | 0.0         | NA               | 0.0               | 0.0           | 0.00      | 0.00           | 0.00                | 49.9             |
| All Vehicles                 |      |           | 1107                  | 2.4 | 1107                  | 2.4 | 0.297     | 0.2         | NA               | 13.4              | 95.9          | 0.01      | 0.01           | 0.01                | 48.3             |

Site Level of Service (LOS) Method: Delay (RTA NSW). Site LOS Method is specified in the Network Data dialog (Override Site Data tab).

Vehicle movement LOS values are based on average delay per movement.

Minor Road Approach LOS values are based on average delay for all vehicle movements.

NA (TWSC): Level of Service is not defined for major road approaches or the intersection as a whole for Two-Way Sign Control (HCM LOS rule).

Two-Way Sign Control Capacity Model: SIDRA Standard.

Delay Model: SIDRA Standard (Control Delay: Geometric Delay is included).

Queue Model: SIDRA queue estimation methods are used for Back of Queue and Queue at Start of Gap.

Gap-Acceptance Capacity Formula: SIDRA Standard (Akçelik M3D).

HV (%) values are calculated for All Movement Classes of All Heavy Vehicle Model Designation.

Arrival Flows used in performance calculations are adjusted to include any Initial Queued Demand and Upstream Capacity Constraint effects.

---

**SIDRA INTERSECTION 9.1 | Copyright © 2000-2022 Akcelik and Associates Pty Ltd | sidrasolutions.com**

Organisation: AECOM AUSTRALIA PTY LTD | Licence: NETWORK / Enterprise Level 1 | Processed: Monday, 17 July 2023 1:41:23 PM

Project: C:\Users\Yeung\AECOM\ANZ-NAC-Sydney Metro-Sydney Metro C&SW Operational Monitoring - General\400\_Technical\432\_Traffic Analysis\SIDRA Modelling\01 Models (Geometry Only)\Block 1\Rev1\\_Review\02 SM C&SW\_CST (Block 1)\_PS.sip9

# MOVEMENT SUMMARY

Site: CST11 [CST11 Oxley St / Clarke Ln (Site Folder: Block 1 Model - 2023 AM Peak)]

Output produced by SIDRA INTERSECTION Version: 9.1.1.200

Network: CST-N1 [CST Network 1 (Network Folder: Block 1 Network - 2023 AM Peak)]

NA  
 Site Category: (None)  
 Give-Way (Two-Way)

| Vehicle Movement Performance |      |           |                       |      |                       |      |           |             |                  |                   |             |           |                |                     |                  |
|------------------------------|------|-----------|-----------------------|------|-----------------------|------|-----------|-------------|------------------|-------------------|-------------|-----------|----------------|---------------------|------------------|
| Mov ID                       | Turn | Mov Class | Demand Flows          |      | Arrival Flows         |      | Deg. Satn | Aver. Delay | Level of Service | 95% Back Of Queue |             | Prop. Que | Eff. Stop Rate | Aver. No. of Cycles | Aver. Speed km/h |
|                              |      |           | [ Total HV ]<br>veh/h | %    | [ Total HV ]<br>veh/h | %    |           |             |                  | [ Veh. veh        | Dist ]<br>m |           |                |                     |                  |
| SouthEast: Clarke Ln (SE)    |      |           |                       |      |                       |      |           |             |                  |                   |             |           |                |                     |                  |
| 1                            | L2   | All MCs   | 1                     | 0.0  | 1                     | 0.0  | 0.008     | 4.9         | LOS A            | 0.0               | 0.2         | 0.40      | 0.55           | 0.40                | 30.2             |
| 2                            | T1   | All MCs   | 1                     | 0.0  | 1                     | 0.0  | 0.008     | 5.2         | LOS A            | 0.0               | 0.2         | 0.40      | 0.55           | 0.40                | 30.2             |
| 3                            | R2   | All MCs   | 3                     | 33.3 | 3                     | 33.3 | 0.008     | 8.3         | LOS A            | 0.0               | 0.2         | 0.40      | 0.55           | 0.40                | 30.2             |
| Approach                     |      |           | 5                     | 20.0 | 5                     | 20.0 | 0.008     | 7.0         | LOS A            | 0.0               | 0.2         | 0.40      | 0.55           | 0.40                | 30.2             |
| NorthEast: Oxley St (NE)     |      |           |                       |      |                       |      |           |             |                  |                   |             |           |                |                     |                  |
| 4                            | L2   | All MCs   | 5                     | 40.0 | 5                     | 40.0 | 0.139     | 3.0         | LOS A            | 3.5               | 24.7        | 0.01      | 0.02           | 0.01                | 35.7             |
| 5                            | T1   | All MCs   | 232                   | 1.4  | 232                   | 1.4  | 0.139     | 0.0         | LOS A            | 3.5               | 24.7        | 0.01      | 0.02           | 0.01                | 48.5             |
| 6                            | R2   | All MCs   | 2                     | 0.0  | 2                     | 0.0  | 0.139     | 3.4         | LOS A            | 3.5               | 24.7        | 0.01      | 0.02           | 0.01                | 48.5             |
| Approach                     |      |           | 239                   | 2.2  | 239                   | 2.2  | 0.139     | 0.1         | NA               | 3.5               | 24.7        | 0.01      | 0.02           | 0.01                | 47.0             |
| NorthWest: Clarke Ln (NW)    |      |           |                       |      |                       |      |           |             |                  |                   |             |           |                |                     |                  |
| 7                            | L2   | All MCs   | 8                     | 0.0  | 8                     | 0.0  | 0.028     | 5.2         | LOS A            | 0.2               | 1.2         | 0.36      | 0.55           | 0.36                | 24.3             |
| 8                            | T1   | All MCs   | 1                     | 0.0  | 1                     | 0.0  | 0.028     | 5.2         | LOS A            | 0.2               | 1.2         | 0.36      | 0.55           | 0.36                | 33.6             |
| 9                            | R2   | All MCs   | 8                     | 0.0  | 8                     | 0.0  | 0.028     | 6.9         | LOS A            | 0.2               | 1.2         | 0.36      | 0.55           | 0.36                | 24.3             |
| Approach                     |      |           | 18                    | 0.0  | 18                    | 0.0  | 0.028     | 6.0         | LOS A            | 0.2               | 1.2         | 0.36      | 0.55           | 0.36                | 25.3             |
| SouthWest: Oxley St (SW)     |      |           |                       |      |                       |      |           |             |                  |                   |             |           |                |                     |                  |
| 10                           | L2   | All MCs   | 5                     | 0.0  | 5                     | 0.0  | 0.115     | 3.0         | LOS A            | 0.0               | 0.2         | 0.01      | 0.03           | 0.01                | 47.7             |
| 11                           | T1   | All MCs   | 214                   | 0.5  | 214                   | 0.5  | 0.115     | 0.0         | LOS A            | 0.0               | 0.2         | 0.01      | 0.03           | 0.01                | 47.7             |
| 12                           | R2   | All MCs   | 3                     | 0.0  | 3                     | 0.0  | 0.115     | 4.0         | LOS A            | 0.0               | 0.2         | 0.01      | 0.03           | 0.01                | 42.6             |
| Approach                     |      |           | 222                   | 0.5  | 222                   | 0.5  | 0.115     | 0.1         | NA               | 0.0               | 0.2         | 0.01      | 0.03           | 0.01                | 47.3             |
| All Vehicles                 |      |           | 484                   | 1.5  | 484                   | 1.5  | 0.139     | 0.4         | NA               | 3.5               | 24.7        | 0.03      | 0.05           | 0.03                | 43.7             |

Site Level of Service (LOS) Method: Delay (RTA NSW). Site LOS Method is specified in the Network Data dialog (Override Site Data tab).

Vehicle movement LOS values are based on average delay per movement.

Minor Road Approach LOS values are based on average delay for all vehicle movements.

NA (TWSC): Level of Service is not defined for major road approaches or the intersection as a whole for Two-Way Sign Control (HCM LOS rule).

Two-Way Sign Control Capacity Model: SIDRA Standard.

Delay Model: SIDRA Standard (Control Delay: Geometric Delay is included).

Queue Model: SIDRA queue estimation methods are used for Back of Queue and Queue at Start of Gap.

Gap-Acceptance Capacity Formula: SIDRA Standard (Akçelik M3D).

HV (%) values are calculated for All Movement Classes of All Heavy Vehicle Model Designation.

Arrival Flows used in performance calculations are adjusted to include any Initial Queued Demand and Upstream Capacity Constraint effects.

---

**SIDRA INTERSECTION 9.1 | Copyright © 2000-2022 Akcelik and Associates Pty Ltd | sidrasolutions.com**

Organisation: AECOM AUSTRALIA PTY LTD | Licence: NETWORK / Enterprise Level 1 | Processed: Monday, 17 July 2023 1:41:23 PM

Project: C:\Users\Yeung\AECOM\ANZ-NAC-Sydney Metro-Sydney Metro C&SW Operational Monitoring - General\400\_Technical\432\_Traffic Analysis\SIDRA Modelling\01 Models (Geometry Only)\Block 1\Rev1\\_Review\02 SM C&SW\_CST (Block 1)\_PS.sip9

# MOVEMENT SUMMARY

 Site: CST12 [CST12 Hume St / Clarke Ln (Site Folder: Block 1 Model - 2023 AM Peak)]

Output produced by SIDRA INTERSECTION Version: 9.1.1.200

■ Network: CST-N1 [CST Network 1 (Network Folder: Block 1 Network - 2023 AM Peak)]

NA  
Site Category: (None)  
Stop (Two-Way)

| Vehicle Movement Performance |      |           |                       |     |                       |     |           |             |                  |                   |             |           |                |                     |                  |
|------------------------------|------|-----------|-----------------------|-----|-----------------------|-----|-----------|-------------|------------------|-------------------|-------------|-----------|----------------|---------------------|------------------|
| Mov ID                       | Turn | Mov Class | Demand Flows          |     | Arrival Flows         |     | Deg. Satn | Aver. Delay | Level of Service | 95% Back Of Queue |             | Prop. Que | Eff. Stop Rate | Aver. No. of Cycles | Aver. Speed km/h |
|                              |      |           | [ Total HV ]<br>veh/h | %   | [ Total HV ]<br>veh/h | %   |           |             |                  | [ Veh. veh        | Dist ]<br>m |           |                |                     |                  |
| SouthEast: Clarke Ln (SE)    |      |           |                       |     |                       |     |           |             |                  |                   |             |           |                |                     |                  |
| 3                            | R2   | All MCs   | 5                     | 0.0 | 5                     | 0.0 | 0.003     | 6.9         | LOS A            | 0.0               | 0.0         | 0.00      | 1.00           | 0.00                | 27.8             |
| Approach                     |      |           | 5                     | 0.0 | 5                     | 0.0 | 0.003     | 6.9         | LOS A            | 0.0               | 0.0         | 0.00      | 1.00           | 0.00                | 27.8             |
| NorthEast: Hume St (NE)      |      |           |                       |     |                       |     |           |             |                  |                   |             |           |                |                     |                  |
| 4                            | L2   | All MCs   | 21                    | 0.0 | 21                    | 0.0 | 0.011     | 3.2         | LOS A            | 0.0               | 0.0         | 0.00      | 0.50           | 0.00                | 34.8             |
| Approach                     |      |           | 21                    | 0.0 | 21                    | 0.0 | 0.011     | 3.2         | NA               | 0.0               | 0.0         | 0.00      | 0.50           | 0.00                | 34.8             |
| All Vehicles                 |      |           | 26                    | 0.0 | 26                    | 0.0 | 0.011     | 3.9         | NA               | 0.0               | 0.0         | 0.00      | 0.60           | 0.00                | 33.5             |

Site Level of Service (LOS) Method: Delay (RTA NSW). Site LOS Method is specified in the Network Data dialog (Override Site Data tab).

Vehicle movement LOS values are based on average delay per movement.

Minor Road Approach LOS values are based on average delay for all vehicle movements.

NA (TWSC): Level of Service is not defined for major road approaches or the intersection as a whole for Two-Way Sign Control (HCM LOS rule).

Two-Way Sign Control Capacity Model: SIDRA Standard.

Delay Model: SIDRA Standard (Control Delay: Geometric Delay is included).

Queue Model: SIDRA queue estimation methods are used for Back of Queue and Queue at Start of Gap.

Gap-Acceptance Capacity Formula: SIDRA Standard (Akçelik M3D).

HV (%) values are calculated for All Movement Classes of All Heavy Vehicle Model Designation.

Arrival Flows used in performance calculations are adjusted to include any Initial Queued Demand and Upstream Capacity Constraint effects.

---

**SIDRA INTERSECTION 9.1 | Copyright © 2000-2022 Akcelik and Associates Pty Ltd | sidrasolutions.com**

Organisation: AECOM AUSTRALIA PTY LTD | Licence: NETWORK / Enterprise Level 1 | Processed: Monday, 17 July 2023 1:41:23 PM

Project: C:\Users\Yeung\AECOM\ANZ-NAC-Sydney Metro-Sydney Metro C&SW Operational Monitoring - General\400\_Technical\432\_Traffic Analysis\SIDRA Modelling\01 Models (Geometry Only)\Block 1\Rev1\\_Review\02 SM C&SW\_CST (Block 1)\_PS.sip9

# MOVEMENT SUMMARY

Site: CST13 [CST13 Pacific Hwy / Alexander St (Site Folder: Block 1 Model - 2023 AM Peak)]

Output produced by SIDRA INTERSECTION Version: 9.1.1.200

Network: CST-N1 [CST Network 1 (Network Folder: Block 1 Network - 2023 AM Peak)]

TCS 763

Site Category: (None)

Signals - EQUISAT (Fixed-Time/SCATS) Coordinated Cycle Time = 135 seconds (Network Site User-Given Phase Times)

| Vehicle Movement Performance |      |           |                       |      |                       |      |           |             |                  |                   |               |           |                |                     |             |
|------------------------------|------|-----------|-----------------------|------|-----------------------|------|-----------|-------------|------------------|-------------------|---------------|-----------|----------------|---------------------|-------------|
| Mov ID                       | Turn | Mov Class | Demand Flows          |      | Arrival Flows         |      | Deg. Satn | Aver. Delay | Level of Service | 95% Back Of Queue |               | Prop. Que | Eff. Stop Rate | Aver. No. of Cycles | Aver. Speed |
|                              |      |           | [ Total HV ]<br>veh/h | %    | [ Total HV ]<br>veh/h | %    |           |             |                  | [ Veh. veh        | [ Dist ]<br>m |           |                |                     |             |
| SouthEast: Pacific Hwy (SE)  |      |           |                       |      |                       |      |           |             |                  |                   |               |           |                |                     |             |
| 2                            | T1   | All MCs   | 949                   | 3.9  | 949                   | 3.9  | 0.422     | 7.9         | LOS A            | 8.9               | 64.0          | 0.57      | 0.50           | 0.57                | 36.3        |
| 3a                           | R1   | All MCs   | 266                   | 7.9  | 266                   | 7.9  | 0.429     | 18.4        | LOS B            | 6.5               | 48.9          | 0.62      | 0.73           | 0.62                | 24.4        |
| Approach                     |      |           | 1216                  | 4.8  | 1216                  | 4.8  | 0.429     | 10.2        | LOS A            | 8.9               | 64.0          | 0.58      | 0.55           | 0.58                | 32.7        |
| North: Alexander St (N)      |      |           |                       |      |                       |      |           |             |                  |                   |               |           |                |                     |             |
| 24a                          | L1   | All MCs   | 269                   | 3.5  | 269                   | 3.5  | *0.420    | 22.3        | LOS B            | 8.8               | 63.7          | 0.76      | 0.75           | 0.76                | 24.2        |
| 26b                          | R3   | All MCs   | 125                   | 0.8  | 125                   | 0.8  | 0.874     | 84.0        | LOS F            | 9.0               | 63.7          | 1.00      | 0.93           | 1.20                | 4.2         |
| Approach                     |      |           | 395                   | 2.7  | 395                   | 2.7  | 0.874     | 41.8        | LOS C            | 9.0               | 63.7          | 0.83      | 0.80           | 0.90                | 14.2        |
| NorthWest: Pacific Hwy (NW)  |      |           |                       |      |                       |      |           |             |                  |                   |               |           |                |                     |             |
| 7b                           | L3   | All MCs   | 18                    | 17.6 | 18                    | 17.6 | 0.125     | 20.4        | LOS B            | 0.3               | 3.1           | 0.13      | 0.29           | 0.13                | 39.3        |
| 8                            | T1   | All MCs   | 1339                  | 4.9  | 1339                  | 4.9  | *0.765    | 15.6        | LOS B            | 20.5              | 146.3         | 0.58      | 0.58           | 0.58                | 39.3        |
| Approach                     |      |           | 1357                  | 5.0  | 1357                  | 5.0  | 0.765     | 15.7        | LOS B            | 20.5              | 146.3         | 0.57      | 0.58           | 0.57                | 39.3        |
| All Vehicles                 |      |           | 2967                  | 4.6  | 2967                  | 4.6  | 0.874     | 16.9        | LOS B            | 20.5              | 146.3         | 0.61      | 0.60           | 0.62                | 30.9        |

Site Level of Service (LOS) Method: Delay (RTA NSW). Site LOS Method is specified in the Network Data dialog (Override Site Data tab).

Vehicle movement LOS values are based on average delay per movement.

Intersection and Approach LOS values are based on average delay for all vehicle movements.

Delay Model: SIDRA Standard (Control Delay: Geometric Delay is included).

Queue Model: SIDRA queue estimation methods are used for Back of Queue and Queue at Start of Green.

Gap-Acceptance Capacity Formula: SIDRA Standard (Akçelik M3D).

HV (%) values are calculated for All Movement Classes of All Heavy Vehicle Model Designation.

Arrival Flows used in performance calculations are adjusted to include any Initial Queued Demand and Upstream Capacity Constraint effects.

\* Critical Movement (Signal Timing)



| Pedestrian Movement Performance |          |           |             |                  |                       |        |           |                |             |              |             |
|---------------------------------|----------|-----------|-------------|------------------|-----------------------|--------|-----------|----------------|-------------|--------------|-------------|
| Mov ID                          | Crossing | Dem. Flow | Aver. Delay | Level of Service | AVERAGE BACK OF QUEUE |        | Prop. Que | Eff. Stop Rate | Travel Time | Travel Dist. | Aver. Speed |
|                                 |          | ped/h     | sec         |                  | [ Ped                 | Dist ] |           |                | sec         | m            | m/sec       |
|                                 |          |           |             |                  | ped                   | m      |           |                |             |              |             |
| North: Alexander St (N)         |          |           |             |                  |                       |        |           |                |             |              |             |
| P6                              | Full     | 342       | 23.1        | LOS C            | 0.6                   | 0.6    | 0.82      | 0.82           | 39.8        | 20.0         | 0.50        |
| NorthWest: Pacific Hwy (NW)     |          |           |             |                  |                       |        |           |                |             |              |             |
| P3                              | Full     | 96        | 55.3        | LOS E            | 0.3                   | 0.3    | 0.91      | 0.91           | 72.0        | 20.0         | 0.28        |
| All Pedestrians                 |          | 438       | 30.2        | LOS D            | 0.6                   | 0.6    | 0.84      | 0.84           | 46.9        | 20.0         | 0.43        |

Level of Service (LOS) Method: SIDRA Pedestrian LOS Method (Based on Average Delay)

Pedestrian movement LOS values are based on average delay per pedestrian movement.

Intersection LOS value for Pedestrians is based on average delay for all pedestrian movements.

---

**SIDRA INTERSECTION 9.1 | Copyright © 2000-2022 Akcelik and Associates Pty Ltd | sidrasolutions.com**

Organisation: AECOM AUSTRALIA PTY LTD | Licence: NETWORK / Enterprise Level 1 | Processed: Monday, 17 July 2023 1:41:23 PM

Project: C:\Users\YeungM\AECOM\ANZ-NAC-Sydney Metro-Sydney Metro C&SW Operational Monitoring - General\400\_Technical\432\_Traffic Analysis\SIDRA Modelling\01 Models (Geometry Only)\Block 1\Rev1\_Review\02 SM C&SW\_CST (Block 1)\_PS.sip9

# MOVEMENT SUMMARY

Site: CST14 [CST14 Falcon St / Alexander St (Site Folder: Block 1 Model - 2023 AM Peak)]

Output produced by SIDRA INTERSECTION Version: 9.1.1.200

Network: CST-N1 [CST Network 1 (Network Folder: Block 1 Network - 2023 AM Peak)]

TCS 764

Site Category: (None)

Signals - EQUISAT (Fixed-Time/SCATS) Coordinated Cycle Time = 135 seconds (Network Site User-Given Phase Times)

| Vehicle Movement Performance |      |           |              |       |               |       |           |             |                  |                   |        |           |                |                     |             |
|------------------------------|------|-----------|--------------|-------|---------------|-------|-----------|-------------|------------------|-------------------|--------|-----------|----------------|---------------------|-------------|
| Mov ID                       | Turn | Mov Class | Demand Flows |       | Arrival Flows |       | Deg. Satn | Aver. Delay | Level of Service | 95% Back Of Queue |        | Prop. Que | Eff. Stop Rate | Aver. No. of Cycles | Aver. Speed |
|                              |      |           | [ Total HV ] | %     | [ Total HV ]  | %     |           |             |                  | [ Veh. veh        | Dist ] |           |                |                     |             |
|                              |      |           | veh/h        | %     | veh/h         | %     | v/c       | sec         |                  |                   |        |           |                |                     | km/h        |
| South: Alexander St (S)      |      |           |              |       |               |       |           |             |                  |                   |        |           |                |                     |             |
| 1                            | L2   | All MCs   | 5            | 20.0  | 5             | 20.0  | 0.835     | 76.8        | LOS F            | 15.8              | 117.8  | 1.00      | 0.96           | 1.14                | 4.9         |
| 2                            | T1   | All MCs   | 246          | 7.3   | 246           | 7.3   | *0.927    | 67.5        | LOS E            | 15.8              | 117.8  | 1.00      | 0.96           | 1.16                | 8.3         |
| 3                            | R2   | All MCs   | 56           | 9.4   | 56            | 9.4   | 0.927     | 93.2        | LOS F            | 5.9               | 44.7   | 1.00      | 0.95           | 1.32                | 14.9        |
| Approach                     |      |           | 307          | 7.9   | 307           | 7.9   | 0.927     | 72.3        | LOS F            | 15.8              | 117.8  | 1.00      | 0.96           | 1.18                | 9.9         |
| East: Falcon St (E)          |      |           |              |       |               |       |           |             |                  |                   |        |           |                |                     |             |
| 4                            | L2   | All MCs   | 41           | 0.0   | 41            | 0.0   | 0.283     | 6.7         | LOS A            | 1.5               | 10.9   | 0.06      | 0.11           | 0.06                | 56.6        |
| 5                            | T1   | All MCs   | 708          | 3.7   | 708           | 3.7   | 0.283     | 0.7         | LOS A            | 13.5              | 99.1   | 0.05      | 0.08           | 0.05                | 57.5        |
| 6                            | R2   | All MCs   | 6            | 100.0 | 6             | 100.0 | 0.283     | 7.3         | LOS A            | 13.5              | 99.1   | 0.04      | 0.04           | 0.04                | 51.9        |
| Approach                     |      |           | 756          | 4.3   | 756           | 4.3   | 0.283     | 1.1         | LOS A            | 13.5              | 99.1   | 0.05      | 0.08           | 0.05                | 57.4        |
| North: Alexander St (N)      |      |           |              |       |               |       |           |             |                  |                   |        |           |                |                     |             |
| 7                            | L2   | All MCs   | 21           | 5.0   | 21            | 5.0   | 0.720     | 71.9        | LOS F            | 13.0              | 93.2   | 1.00      | 0.87           | 1.06                | 18.9        |
| 8                            | T1   | All MCs   | 391          | 2.7   | 391           | 2.7   | 0.720     | 60.7        | LOS E            | 13.8              | 98.7   | 1.00      | 0.87           | 1.05                | 5.6         |
| Approach                     |      |           | 412          | 2.8   | 412           | 2.8   | 0.720     | 61.3        | LOS E            | 13.8              | 98.7   | 1.00      | 0.87           | 1.05                | 6.5         |
| West: Falcon St (W)          |      |           |              |       |               |       |           |             |                  |                   |        |           |                |                     |             |
| 10                           | L2   | All MCs   | 176          | 3.6   | 176           | 3.6   | *0.319    | 5.8         | LOS A            | 1.1               | 7.6    | 0.04      | 0.27           | 0.04                | 39.4        |
| 11                           | T1   | All MCs   | 705          | 3.6   | 705           | 3.6   | 0.319     | 0.4         | LOS A            | 1.1               | 7.6    | 0.04      | 0.12           | 0.04                | 57.7        |
| Approach                     |      |           | 881          | 3.6   | 881           | 3.6   | 0.319     | 1.5         | LOS A            | 1.1               | 7.6    | 0.04      | 0.15           | 0.04                | 55.5        |
| All Vehicles                 |      |           | 2356         | 4.2   | 2356          | 4.2   | 0.927     | 21.0        | LOS B            | 15.8              | 117.8  | 0.34      | 0.36           | 0.37                | 29.4        |

Site Level of Service (LOS) Method: Delay (RTA NSW). Site LOS Method is specified in the Network Data dialog (Override Site Data tab).

Vehicle movement LOS values are based on average delay per movement.

Intersection and Approach LOS values are based on average delay for all vehicle movements.

Delay Model: SIDRA Standard (Control Delay: Geometric Delay is included).

Queue Model: SIDRA queue estimation methods are used for Back of Queue and Queue at Start of Green.

Gap-Acceptance Capacity Formula: SIDRA Standard (Akçelik M3D).

HV (%) values are calculated for All Movement Classes of All Heavy Vehicle Model Designation.

Arrival Flows used in performance calculations are adjusted to include any Initial Queued Demand and Upstream Capacity Constraint effects.

\* Critical Movement (Signal Timing)

| Pedestrian Movement Performance |          |           |             |                  |                       |        |           |                |             |              |             |
|---------------------------------|----------|-----------|-------------|------------------|-----------------------|--------|-----------|----------------|-------------|--------------|-------------|
| Mov ID                          | Crossing | Dem. Flow | Aver. Delay | Level of Service | AVERAGE BACK OF QUEUE |        | Prop. Que | Eff. Stop Rate | Travel Time | Travel Dist. | Aver. Speed |
|                                 |          | ped/h     | sec         |                  | [ Ped                 | Dist ] |           |                | sec         | m            | m/sec       |
|                                 |          |           |             |                  | ped                   | m      |           |                |             |              |             |
| South: Alexander St (S)         |          |           |             |                  |                       |        |           |                |             |              |             |
| P1                              | Full     | 135       | 57.3        | LOS E            | 0.5                   | 0.5    | 0.92      | 0.92           | 73.9        | 20.0         | 0.27        |
| East: Falcon St (E)             |          |           |             |                  |                       |        |           |                |             |              |             |
| P2                              | Full     | 89        | 57.2        | LOS E            | 0.3                   | 0.3    | 0.92      | 0.92           | 73.8        | 20.0         | 0.27        |
| North: Alexander St (N)         |          |           |             |                  |                       |        |           |                |             |              |             |
| P3                              | Full     | 99        | 57.2        | LOS E            | 0.4                   | 0.4    | 0.92      | 0.92           | 73.9        | 20.0         | 0.27        |
| West: Falcon St (W)             |          |           |             |                  |                       |        |           |                |             |              |             |
| P4                              | Full     | 167       | 57.3        | LOS E            | 0.6                   | 0.6    | 0.92      | 0.92           | 74.0        | 20.0         | 0.27        |
| All Pedestrians                 |          | 491       | 57.3        | LOS E            | 0.6                   | 0.6    | 0.92      | 0.92           | 73.9        | 20.0         | 0.27        |

Level of Service (LOS) Method: SIDRA Pedestrian LOS Method (Based on Average Delay)

Pedestrian movement LOS values are based on average delay per pedestrian movement.

Intersection LOS value for Pedestrians is based on average delay for all pedestrian movements.

**SIDRA INTERSECTION 9.1 | Copyright © 2000-2022 Akcelik and Associates Pty Ltd | sidrasolutions.com**

Organisation: AECOM AUSTRALIA PTY LTD | Licence: NETWORK / Enterprise Level 1 | Processed: Monday, 17 July 2023 1:41:23 PM

Project: C:\Users\YeungMA\AECOM\ANZ-NAC-Sydney Metro-Sydney Metro C&SW Operational Monitoring - General\400\_Technical\432\_Traffic Analysis\SIDRA Modelling\01 Models (Geometry Only)\Block 1\Rev1\_Review\02 SM C&SW\_CST (Block 1)\_PS.sip9

# MOVEMENT SUMMARY

Site: CST01 [CST01 Pacific Hwy / Albany St (Site Folder: Block 1 Model - 2023 PM Peak)]

Output produced by SIDRA INTERSECTION Version: 9.1.1.200

Network: CST-N1 [CST Network 1 (Network Folder: Block 1 Network - 2023 PM Peak)]

TCS 768

Site Category: (None)

Signals - EQUISAT (Fixed-Time/SCATS) Coordinated Cycle Time = 125 seconds (Network User-Given Cycle Time)

| Vehicle Movement Performance |      |           |                       |     |                       |     |           |             |                  |                   |               |           |                |                     |             |
|------------------------------|------|-----------|-----------------------|-----|-----------------------|-----|-----------|-------------|------------------|-------------------|---------------|-----------|----------------|---------------------|-------------|
| Mov ID                       | Turn | Mov Class | Demand Flows          |     | Arrival Flows         |     | Deg. Satn | Aver. Delay | Level of Service | 95% Back Of Queue |               | Prop. Que | Eff. Stop Rate | Aver. No. of Cycles | Aver. Speed |
|                              |      |           | [ Total HV ]<br>veh/h | %   | [ Total HV ]<br>veh/h | %   |           |             |                  | [ Veh. veh        | [ Dist ]<br>m |           |                |                     |             |
| SouthEast: Pacific Hwy (SE)  |      |           |                       |     |                       |     |           |             |                  |                   |               |           |                |                     |             |
| 22                           | T1   | All MCs   | 1007                  | 4.8 | 1007                  | 4.8 | 0.387     | 11.9        | LOS A            | 17.6              | 128.3         | 0.56      | 0.40           | 0.56                | 38.5        |
| 23b                          | R3   | All MCs   | 140                   | 0.0 | 140                   | 0.0 | *0.220    | 39.1        | LOS C            | 6.1               | 42.8          | 0.76      | 0.78           | 0.76                | 13.0        |
| Approach                     |      |           | 1147                  | 4.2 | 1147                  | 4.2 | 0.387     | 15.3        | LOS B            | 17.6              | 128.3         | 0.59      | 0.44           | 0.59                | 33.9        |
| East: Albany St (E)          |      |           |                       |     |                       |     |           |             |                  |                   |               |           |                |                     |             |
| 4b                           | L3   | All MCs   | 37                    | 0.0 | 37                    | 0.0 | *0.889    | 78.0        | LOS F            | 6.9               | 49.0          | 1.00      | 1.02           | 1.27                | 2.3         |
| 6a                           | R1   | All MCs   | 545                   | 2.1 | 545                   | 2.1 | 0.889     | 67.6        | LOS E            | 6.9               | 49.0          | 1.00      | 1.02           | 1.26                | 8.7         |
| Approach                     |      |           | 582                   | 2.0 | 582                   | 2.0 | 0.889     | 68.2        | LOS E            | 6.9               | 49.0          | 1.00      | 1.02           | 1.26                | 8.3         |
| NorthWest: Pacific Hwy (NW)  |      |           |                       |     |                       |     |           |             |                  |                   |               |           |                |                     |             |
| 27a                          | L1   | All MCs   | 423                   | 0.0 | 423                   | 0.0 | 0.659     | 35.6        | LOS C            | 20.1              | 141.0         | 0.84      | 0.82           | 0.84                | 13.1        |
| 28                           | T1   | All MCs   | 924                   | 3.5 | 924                   | 3.5 | *0.902    | 60.4        | LOS E            | 31.6              | 227.7         | 1.00      | 1.07           | 1.21                | 8.5         |
| Approach                     |      |           | 1347                  | 2.4 | 1347                  | 2.4 | 0.902     | 52.6        | LOS D            | 31.6              | 227.7         | 0.95      | 0.99           | 1.09                | 9.6         |
| All Vehicles                 |      |           | 3077                  | 3.0 | 3077                  | 3.0 | 0.902     | 41.6        | LOS C            | 31.6              | 227.7         | 0.82      | 0.79           | 0.94                | 14.4        |

Site Level of Service (LOS) Method: Delay (RTA NSW). Site LOS Method is specified in the Network Data dialog (Override Site Data tab).

Vehicle movement LOS values are based on average delay per movement.

Intersection and Approach LOS values are based on average delay for all vehicle movements.

Delay Model: SIDRA Standard (Control Delay: Geometric Delay is included).

Queue Model: SIDRA queue estimation methods are used for Back of Queue and Queue at Start of Green.

Gap-Acceptance Capacity Formula: SIDRA Standard (Akçelik M3D).

HV (%) values are calculated for All Movement Classes of All Heavy Vehicle Model Designation.

Arrival Flows used in performance calculations are adjusted to include any Initial Queued Demand and Upstream Capacity Constraint effects.

\* Critical Movement (Signal Timing)

| Pedestrian Movement Performance |          |           |             |                  |                       |        |           |                |             |              |             |
|---------------------------------|----------|-----------|-------------|------------------|-----------------------|--------|-----------|----------------|-------------|--------------|-------------|
| Mov ID                          | Crossing | Dem. Flow | Aver. Delay | Level of Service | AVERAGE BACK OF QUEUE |        | Prop. Que | Eff. Stop Rate | Travel Time | Travel Dist. | Aver. Speed |
|                                 |          | ped/h     | sec         |                  | [ Ped                 | Dist ] |           |                | sec         | m            | m/sec       |
|                                 |          |           |             |                  | ped                   | m      |           |                |             |              |             |
| SouthEast: Pacific Hwy (SE)     |          |           |             |                  |                       |        |           |                |             |              |             |
| P5                              | Full     | 178       | 50.6        | LOS E            | 0.6                   | 0.6    | 0.90      | 0.90           | 217.2       | 200.0        | 0.92        |
| East: Albany St (E)             |          |           |             |                  |                       |        |           |                |             |              |             |
| P2                              | Full     | 242       | 50.7        | LOS E            | 0.8                   | 0.8    | 0.91      | 0.91           | 67.4        | 20.0         | 0.30        |
| All Pedestrians                 |          | 420       | 50.6        | LOS E            | 0.8                   | 0.8    | 0.90      | 0.90           | 130.8       | 96.2         | 0.74        |

Level of Service (LOS) Method: SIDRA Pedestrian LOS Method (Based on Average Delay)

Pedestrian movement LOS values are based on average delay per pedestrian movement.

Intersection LOS value for Pedestrians is based on average delay for all pedestrian movements.

---

**SIDRA INTERSECTION 9.1 | Copyright © 2000-2022 Akcelik and Associates Pty Ltd | sidrasolutions.com**

Organisation: AECOM AUSTRALIA PTY LTD | Licence: NETWORK / Enterprise Level 1 | Processed: Monday, 17 July 2023 1:41:32 PM

Project: C:\Users\YeungMAE\COMANZ-NAC-Sydney Metro-Sydney Metro C&SW Operational Monitoring - General\400\_Technical\432\_Traffic Analysis\SIDRA Modelling\01 Models (Geometry Only)\Block 1\Rev1\_Review\02 SM C&SW\_CST (Block 1)\_PS.sip9

# MOVEMENT SUMMARY

Site: CST02 [CST02 Pacific Hwy / Oxley St (Site Folder: Block 1 Model - 2023 PM Peak)]

Output produced by SIDRA INTERSECTION Version: 9.1.1.200

Network: CST-N1 [CST Network 1 (Network Folder: Block 1 Network - 2023 PM Peak)]

TCS 767

Site Category: (None)

Signals - EQUISAT (Fixed-Time/SCATS) Coordinated Cycle Time = 125 seconds (Network User-Given Cycle Time)

| Vehicle Movement Performance |      |           |                       |     |                       |     |           |             |                  |                   |               |           |                |                     |                  |
|------------------------------|------|-----------|-----------------------|-----|-----------------------|-----|-----------|-------------|------------------|-------------------|---------------|-----------|----------------|---------------------|------------------|
| Mov ID                       | Turn | Mov Class | Demand Flows          |     | Arrival Flows         |     | Deg. Satn | Aver. Delay | Level of Service | 95% Back Of Queue |               | Prop. Que | Eff. Stop Rate | Aver. No. of Cycles | Aver. Speed km/h |
|                              |      |           | [ Total HV ]<br>veh/h | %   | [ Total HV ]<br>veh/h | %   |           |             |                  | [ Veh. veh        | [ Dist ]<br>m |           |                |                     |                  |
| SouthEast: Pacific Hwy (SE)  |      |           |                       |     |                       |     |           |             |                  |                   |               |           |                |                     |                  |
| 1                            | L2   | All MCs   | 118                   | 0.0 | 118                   | 0.0 | 0.105     | 7.7         | LOS A            | 0.9               | 6.0           | 0.11      | 0.55           | 0.11                | 39.7             |
| 2                            | T1   | All MCs   | 947                   | 5.0 | 947                   | 5.0 | 0.345     | 2.8         | LOS A            | 5.6               | 41.1          | 0.20      | 0.19           | 0.20                | 43.9             |
| Approach                     |      |           | 1065                  | 4.4 | 1065                  | 4.4 | 0.345     | 3.4         | LOS A            | 5.6               | 41.1          | 0.19      | 0.23           | 0.19                | 42.7             |
| NorthEast: Oxley St (NE)     |      |           |                       |     |                       |     |           |             |                  |                   |               |           |                |                     |                  |
| 4                            | L2   | All MCs   | 82                    | 0.0 | 82                    | 0.0 | 0.325     | 56.6        | LOS E            | 4.6               | 32.4          | 0.95      | 0.76           | 0.95                | 2.7              |
| 5                            | T1   | All MCs   | 154                   | 0.0 | 154                   | 0.0 | 0.704     | 60.7        | LOS E            | 7.0               | 49.0          | 1.00      | 0.86           | 1.07                | 13.4             |
| Approach                     |      |           | 236                   | 0.0 | 236                   | 0.0 | 0.704     | 59.3        | LOS E            | 7.0               | 49.0          | 0.98      | 0.83           | 1.03                | 10.4             |
| NorthWest: Pacific Hwy (NW)  |      |           |                       |     |                       |     |           |             |                  |                   |               |           |                |                     |                  |
| 7                            | L2   | All MCs   | 65                    | 0.0 | 65                    | 0.0 | 0.050     | 22.5        | LOS B            | 2.2               | 15.5          | 0.60      | 0.54           | 0.60                | 21.9             |
| 8                            | T1   | All MCs   | 916                   | 3.6 | 916                   | 3.6 | *0.347    | 14.9        | LOS B            | 18.2              | 131.6         | 0.66      | 0.36           | 0.66                | 26.6             |
| Approach                     |      |           | 981                   | 3.3 | 981                   | 3.3 | 0.347     | 15.4        | LOS B            | 18.2              | 131.6         | 0.66      | 0.38           | 0.66                | 26.2             |
| SouthWest: Oxley St (SW)     |      |           |                       |     |                       |     |           |             |                  |                   |               |           |                |                     |                  |
| 10                           | L2   | All MCs   | 223                   | 0.9 | 223                   | 0.9 | *0.899    | 91.0        | LOS F            | 15.7              | 110.5         | 1.00      | 1.02           | 1.33                | 10.4             |
| 11                           | T1   | All MCs   | 166                   | 0.0 | 166                   | 0.0 | 0.547     | 68.6        | LOS E            | 9.4               | 66.1          | 0.97      | 0.79           | 0.97                | 13.9             |
| 12                           | R2   | All MCs   | 117                   | 2.7 | 117                   | 2.7 | 0.930     | 84.7        | LOS F            | 8.5               | 60.9          | 1.00      | 1.07           | 1.50                | 9.4              |
| Approach                     |      |           | 506                   | 1.0 | 506                   | 1.0 | 0.930     | 82.2        | LOS F            | 15.7              | 110.5         | 0.99      | 0.95           | 1.25                | 11.1             |
| All Vehicles                 |      |           | 2788                  | 3.1 | 2788                  | 3.1 | 0.930     | 26.6        | LOS B            | 18.2              | 131.6         | 0.57      | 0.46           | 0.62                | 18.9             |

Site Level of Service (LOS) Method: Delay (RTA NSW). Site LOS Method is specified in the Network Data dialog (Override Site Data tab).

Vehicle movement LOS values are based on average delay per movement.

Intersection and Approach LOS values are based on average delay for all vehicle movements.

Delay Model: SIDRA Standard (Control Delay: Geometric Delay is included).

Queue Model: SIDRA queue estimation methods are used for Back of Queue and Queue at Start of Green.

Gap-Acceptance Capacity Formula: SIDRA Standard (Akçelik M3D).

HV (%) values are calculated for All Movement Classes of All Heavy Vehicle Model Designation.

Arrival Flows used in performance calculations are adjusted to include any Initial Queued Demand and Upstream Capacity Constraint effects.

\* Critical Movement (Signal Timing)

| Pedestrian Movement Performance |          |           |             |                  |                       |        |           |                |             |              |             |
|---------------------------------|----------|-----------|-------------|------------------|-----------------------|--------|-----------|----------------|-------------|--------------|-------------|
| Mov ID                          | Crossing | Dem. Flow | Aver. Delay | Level of Service | AVERAGE BACK OF QUEUE |        | Prop. Que | Eff. Stop Rate | Travel Time | Travel Dist. | Aver. Speed |
|                                 |          | ped/h     | sec         |                  | [ Ped                 | Dist ] |           |                | sec         | m            | m/sec       |
|                                 |          |           |             |                  | ped                   | m      |           |                |             |              |             |
| SouthEast: Pacific Hwy (SE)     |          |           |             |                  |                       |        |           |                |             |              |             |
| P1                              | Full     | 124       | 50.4        | LOS E            | 0.4                   | 0.4    | 0.90      | 0.90           | 67.1        | 20.0         | 0.30        |
| NorthEast: Oxley St (NE)        |          |           |             |                  |                       |        |           |                |             |              |             |
| P2                              | Full     | 49        | 51.2        | LOS E            | 0.2                   | 0.2    | 0.91      | 0.91           | 67.8        | 20.0         | 0.29        |
| SouthWest: Oxley St (SW)        |          |           |             |                  |                       |        |           |                |             |              |             |
| P4                              | Full     | 136       | 51.4        | LOS E            | 0.4                   | 0.4    | 0.91      | 0.91           | 68.0        | 20.0         | 0.29        |
| All Pedestrians                 |          | 309       | 51.0        | LOS E            | 0.4                   | 0.4    | 0.91      | 0.91           | 67.6        | 20.0         | 0.30        |

Level of Service (LOS) Method: SIDRA Pedestrian LOS Method (Based on Average Delay)

Pedestrian movement LOS values are based on average delay per pedestrian movement.

Intersection LOS value for Pedestrians is based on average delay for all pedestrian movements.

**SIDRA INTERSECTION 9.1 | Copyright © 2000-2022 Akcelik and Associates Pty Ltd | sidrasolutions.com**

Organisation: AECOM AUSTRALIA PTY LTD | Licence: NETWORK / Enterprise Level 1 | Processed: Monday, 17 July 2023 1:41:32 PM

Project: C:\Users\YeungM\AECOM\ANZ-NAC-Sydney Metro-Sydney Metro C&SW Operational Monitoring - General\400\_Technical\432\_Traffic Analysis\SIDRA Modelling\01 Models (Geometry Only)\Block 1\Rev1\_Review\02 SM C&SW\_CST (Block 1)\_PS.sip9



# MOVEMENT SUMMARY

Site: CST03 [CST03 Pacific Hwy / Hume St (Site Folder: Block 1 Model - 2023 PM Peak)]

Output produced by SIDRA INTERSECTION Version: 9.1.1.200

Network: CST-N1 [CST Network 1 (Network Folder: Block 1 Network - 2023 PM Peak)]

TCS 766

Site Category: (None)

Signals - EQUISAT (Fixed-Time/SCATS) Coordinated Cycle Time = 125 seconds (Network User-Given Cycle Time)

| Vehicle Movement Performance |      |           |                       |       |                       |       |           |             |                  |                   |               |           |                |                     |                  |
|------------------------------|------|-----------|-----------------------|-------|-----------------------|-------|-----------|-------------|------------------|-------------------|---------------|-----------|----------------|---------------------|------------------|
| Mov ID                       | Turn | Mov Class | Demand Flows          |       | Arrival Flows         |       | Deg. Satn | Aver. Delay | Level of Service | 95% Back Of Queue |               | Prop. Que | Eff. Stop Rate | Aver. No. of Cycles | Aver. Speed km/h |
|                              |      |           | [ Total HV ]<br>veh/h | %     | [ Total HV ]<br>veh/h | %     |           |             |                  | [ Veh. veh        | [ Dist ]<br>m |           |                |                     |                  |
| SouthEast: Pacific Hwy (SE)  |      |           |                       |       |                       |       |           |             |                  |                   |               |           |                |                     |                  |
| 1                            | L2   | All MCs   | 47                    | 0.0   | 47                    | 0.0   | 0.244     | 6.3         | LOS A            | 0.9               | 6.7           | 0.05      | 0.12           | 0.05                | 36.5             |
| 2                            | T1   | All MCs   | 1006                  | 4.7   | 1006                  | 4.7   | 0.244     | 3.7         | LOS A            | 7.2               | 52.6          | 0.27      | 0.23           | 0.27                | 45.7             |
| Approach                     |      |           | 1054                  | 4.5   | 1054                  | 4.5   | 0.244     | 3.8         | LOS A            | 7.2               | 52.6          | 0.26      | 0.22           | 0.26                | 45.0             |
| NorthWest: Pacific Hwy (NW)  |      |           |                       |       |                       |       |           |             |                  |                   |               |           |                |                     |                  |
| 8                            | T1   | All MCs   | 1116                  | 3.2   | 1116                  | 3.2   | 0.384     | 0.8         | LOS A            | 2.5               | 18.1          | 0.08      | 0.07           | 0.08                | 54.7             |
| 9                            | R2   | All MCs   | 1000                  | 100.0 | 1000                  | 100.0 | *0.384    | 7.6         | LOS A            | 2.4               | 17.1          | 0.08      | 0.07           | 0.08                | 26.1             |
| Approach                     |      |           | 1117                  | 3.3   | 1117                  | 3.3   | 0.384     | 0.8         | LOS A            | 2.5               | 18.1          | 0.08      | 0.07           | 0.08                | 54.6             |
| SouthWest: Hume St (SW)      |      |           |                       |       |                       |       |           |             |                  |                   |               |           |                |                     |                  |
| 10                           | L2   | All MCs   | 59                    | 0.0   | 59                    | 0.0   | *0.283    | 60.8        | LOS E            | 3.4               | 23.7          | 0.96      | 0.75           | 0.96                | 4.6              |
| 12                           | R2   | All MCs   | 23                    | 0.0   | 23                    | 0.0   | 0.111     | 59.2        | LOS E            | 1.3               | 9.1           | 0.93      | 0.71           | 0.93                | 4.9              |
| Approach                     |      |           | 82                    | 0.0   | 82                    | 0.0   | 0.283     | 60.4        | LOS E            | 3.4               | 23.7          | 0.95      | 0.74           | 0.95                | 4.7              |
| All Vehicles                 |      |           | 2253                  | 3.7   | 2253                  | 3.7   | 0.384     | 4.4         | LOS A            | 7.2               | 52.6          | 0.20      | 0.17           | 0.20                | 41.2             |

Site Level of Service (LOS) Method: Delay (RTA NSW). Site LOS Method is specified in the Network Data dialog (Override Site Data tab).

Vehicle movement LOS values are based on average delay per movement.

Intersection and Approach LOS values are based on average delay for all vehicle movements.

Delay Model: SIDRA Standard (Control Delay: Geometric Delay is included).

Queue Model: SIDRA queue estimation methods are used for Back of Queue and Queue at Start of Green.

Gap-Acceptance Capacity Formula: SIDRA Standard (Akçelik M3D).

HV (%) values are calculated for All Movement Classes of All Heavy Vehicle Model Designation.

Arrival Flows used in performance calculations are adjusted to include any Initial Queued Demand and Upstream Capacity Constraint effects.

\* Critical Movement (Signal Timing)

| Pedestrian Movement Performance |          |           |             |                  |                       |        |           |                |             |              |             |
|---------------------------------|----------|-----------|-------------|------------------|-----------------------|--------|-----------|----------------|-------------|--------------|-------------|
| Mov ID                          | Crossing | Dem. Flow | Aver. Delay | Level of Service | AVERAGE BACK OF QUEUE |        | Prop. Que | Eff. Stop Rate | Travel Time | Travel Dist. | Aver. Speed |
|                                 |          | ped/h     | sec         |                  | [ Ped                 | Dist ] |           |                | sec         | m            | m/sec       |
|                                 |          |           |             |                  | ped                   | m      |           |                |             |              |             |
| SouthEast: Pacific Hwy (SE)     |          |           |             |                  |                       |        |           |                |             |              |             |
| P1                              | Full     | 14        | 50.2        | LOS E            | 0.0                   | 0.0    | 0.90      | 0.90           | 66.9        | 20.0         | 0.30        |
| NorthWest: Pacific Hwy (NW)     |          |           |             |                  |                       |        |           |                |             |              |             |
| P3                              | Full     | 21        | 50.2        | LOS E            | 0.1                   | 0.1    | 0.90      | 0.90           | 66.9        | 20.0         | 0.30        |
| SouthWest: Hume St (SW)         |          |           |             |                  |                       |        |           |                |             |              |             |
| P4                              | Full     | 136       | 53.2        | LOS E            | 0.4                   | 0.4    | 0.93      | 0.93           | 69.9        | 20.0         | 0.29        |
| All Pedestrians                 |          | 171       | 52.6        | LOS E            | 0.4                   | 0.4    | 0.92      | 0.92           | 69.3        | 20.0         | 0.29        |

Level of Service (LOS) Method: SIDRA Pedestrian LOS Method (Based on Average Delay)

Pedestrian movement LOS values are based on average delay per pedestrian movement.

Intersection LOS value for Pedestrians is based on average delay for all pedestrian movements.

**SIDRA INTERSECTION 9.1 | Copyright © 2000-2022 Akcelik and Associates Pty Ltd | sidrasolutions.com**

Organisation: AECOM AUSTRALIA PTY LTD | Licence: NETWORK / Enterprise Level 1 | Processed: Monday, 17 July 2023 1:41:32 PM

Project: C:\Users\YeungM\AECOM\ANZ-NAC-Sydney Metro-Sydney Metro C&SW Operational Monitoring - General\400\_Technical\432\_Traffic Analysis\SIDRA Modelling\01 Models (Geometry Only)\Block 1\Rev1\_Review\02 SM C&SW\_CST (Block 1)\_PS.sip9

# MOVEMENT SUMMARY

Site: CST04 [CST04 Pacific Hwy / Falcon St / Shirley Rd (Site Folder: Block 1 Model - 2023 PM Peak)]

Output produced by SIDRA INTERSECTION Version: 9.1.1.200

Network: CST-N1 [CST Network 1 (Network Folder: Block 1 Network - 2023 PM Peak)]

TCS 765

Site Category: (None)

Signals - EQUISAT (Fixed-Time/SCATS) Coordinated Cycle Time = 125 seconds (Network User-Given Cycle Time)

| Vehicle Movement Performance |      |           |                       |     |                       |     |           |             |                  |                   |               |           |                |                     |                  |
|------------------------------|------|-----------|-----------------------|-----|-----------------------|-----|-----------|-------------|------------------|-------------------|---------------|-----------|----------------|---------------------|------------------|
| Mov ID                       | Turn | Mov Class | Demand Flows          |     | Arrival Flows         |     | Deg. Satn | Aver. Delay | Level of Service | 95% Back Of Queue |               | Prop. Que | Eff. Stop Rate | Aver. No. of Cycles | Aver. Speed km/h |
|                              |      |           | [ Total HV ]<br>veh/h | %   | [ Total HV ]<br>veh/h | %   |           |             |                  | [ Veh. veh        | [ Dist ]<br>m |           |                |                     |                  |
| SouthEast: Pacific Hwy (SE)  |      |           |                       |     |                       |     |           |             |                  |                   |               |           |                |                     |                  |
| 1                            | L2   | All MCs   | 467                   | 0.7 | 467                   | 0.7 | 0.537     | 30.0        | LOS C            | 19.8              | 139.3         | 0.75      | 0.81           | 0.75                | 22.4             |
| 2                            | T1   | All MCs   | 619                   | 6.0 | 619                   | 6.0 | 0.500     | 31.5        | LOS C            | 14.2              | 104.8         | 0.80      | 0.68           | 0.80                | 12.4             |
| Approach                     |      |           | 1086                  | 3.7 | 1086                  | 3.7 | 0.537     | 30.9        | LOS C            | 19.8              | 139.3         | 0.78      | 0.74           | 0.78                | 17.5             |
| East: Falcon St (E)          |      |           |                       |     |                       |     |           |             |                  |                   |               |           |                |                     |                  |
| 21b                          | L3   | All MCs   | 17                    | 0.0 | 17                    | 0.0 | 0.944     | 26.4        | LOS B            | 18.6              | 130.6         | 0.98      | 1.00           | 1.17                | 7.1              |
| 21a                          | L1   | All MCs   | 521                   | 0.2 | 521                   | 0.2 | *0.944    | 45.9        | LOS D            | 18.6              | 130.6         | 0.98      | 1.00           | 1.17                | 16.5             |
| 23a                          | R1   | All MCs   | 403                   | 2.6 | 403                   | 2.6 | 0.589     | 23.7        | LOS B            | 14.8              | 105.9         | 0.65      | 0.74           | 0.65                | 11.8             |
| Approach                     |      |           | 941                   | 1.2 | 941                   | 1.2 | 0.944     | 36.0        | LOS C            | 18.6              | 130.6         | 0.84      | 0.89           | 0.95                | 15.2             |
| North: Willoughby Rd (N)     |      |           |                       |     |                       |     |           |             |                  |                   |               |           |                |                     |                  |
| 7                            | L2   | All MCs   | 37                    | 0.0 | 37                    | 0.0 | 0.026     | 3.8         | LOS A            | 0.2               | 1.2           | 0.09      | 0.48           | 0.09                | 36.9             |
| Approach                     |      |           | 37                    | 0.0 | 37                    | 0.0 | 0.026     | 3.8         | LOS A            | 0.2               | 1.2           | 0.09      | 0.48           | 0.09                | 36.9             |
| NorthWest: Pacific Hwy (NW)  |      |           |                       |     |                       |     |           |             |                  |                   |               |           |                |                     |                  |
| 7a                           | L1   | All MCs   | 435                   | 2.4 | 435                   | 2.4 | *0.442    | 14.5        | LOS B            | 8.3               | 59.4          | 0.66      | 0.76           | 0.66                | 27.6             |
| 8                            | T1   | All MCs   | 703                   | 3.6 | 703                   | 3.6 | 0.556     | 10.7        | LOS A            | 8.6               | 61.8          | 0.41      | 0.35           | 0.41                | 32.6             |
| Approach                     |      |           | 1138                  | 3.1 | 1138                  | 3.1 | 0.556     | 12.2        | LOS A            | 8.6               | 61.8          | 0.51      | 0.51           | 0.51                | 30.6             |
| SouthWest: Shirley Rd (SW)   |      |           |                       |     |                       |     |           |             |                  |                   |               |           |                |                     |                  |
| 10                           | L2   | All MCs   | 32                    | 0.0 | 32                    | 0.0 | 0.963     | 92.0        | LOS F            | 22.6              | 158.9         | 1.00      | 1.18           | 1.43                | 8.3              |
| 12a                          | R1   | All MCs   | 401                   | 0.5 | 401                   | 0.5 | *0.963    | 83.5        | LOS F            | 23.9              | 169.3         | 1.00      | 1.16           | 1.43                | 8.3              |
| 12                           | R2   | All MCs   | 191                   | 1.7 | 191                   | 1.7 | 0.963     | 85.7        | LOS F            | 23.9              | 169.3         | 1.00      | 1.13           | 1.42                | 8.1              |
| Approach                     |      |           | 623                   | 0.8 | 623                   | 0.8 | 0.963     | 84.6        | LOS F            | 23.9              | 169.3         | 1.00      | 1.15           | 1.43                | 8.2              |
| All Vehicles                 |      |           | 3825                  | 2.4 | 3825                  | 2.4 | 0.963     | 35.1        | LOS C            | 23.9              | 169.3         | 0.74      | 0.77           | 0.84                | 16.0             |

Site Level of Service (LOS) Method: Delay (RTA NSW). Site LOS Method is specified in the Network Data dialog (Override Site Data tab).

Vehicle movement LOS values are based on average delay per movement.

Intersection and Approach LOS values are based on average delay for all vehicle movements.

Delay Model: SIDRA Standard (Control Delay: Geometric Delay is included).

Queue Model: SIDRA queue estimation methods are used for Back of Queue and Queue at Start of Green.

Gap-Acceptance Capacity Formula: SIDRA Standard (Akçelik M3D).

HV (%) values are calculated for All Movement Classes of All Heavy Vehicle Model Designation.

Arrival Flows used in performance calculations are adjusted to include any Initial Queued Demand and Upstream Capacity Constraint effects.

\* Critical Movement (Signal Timing)

| Pedestrian Movement Performance |          |                    |                    |                  |                       |             |           |                |                    |                   |                      |
|---------------------------------|----------|--------------------|--------------------|------------------|-----------------------|-------------|-----------|----------------|--------------------|-------------------|----------------------|
| Mov ID                          | Crossing | Dem. Flow<br>ped/h | Aver. Delay<br>sec | Level of Service | AVERAGE BACK OF QUEUE |             | Prop. Que | Eff. Stop Rate | Travel Time<br>sec | Travel Dist.<br>m | Aver. Speed<br>m/sec |
|                                 |          |                    |                    |                  | [ Ped<br>ped          | Dist ]<br>m |           |                |                    |                   |                      |
| SouthEast: Pacific Hwy (SE)     |          |                    |                    |                  |                       |             |           |                |                    |                   |                      |
| P1                              | Full     | 117                | 49.5               | LOS E            | 0.4                   | 0.4         | 0.89      | 0.89           | 66.2               | 20.0              | 0.30                 |
| East: Falcon St (E)             |          |                    |                    |                  |                       |             |           |                |                    |                   |                      |
| P5                              | Full     | 177                | 53.3               | LOS E            | 0.6                   | 0.6         | 0.93      | 0.93           | 70.0               | 20.0              | 0.29                 |
| NorthWest: Pacific Hwy (NW)     |          |                    |                    |                  |                       |             |           |                |                    |                   |                      |
| P3                              | Full     | 288                | 49.9               | LOS E            | 0.9                   | 0.9         | 0.90      | 0.90           | 66.6               | 20.0              | 0.30                 |
| SouthWest: Shirley Rd (SW)      |          |                    |                    |                  |                       |             |           |                |                    |                   |                      |
| P4                              | Full     | 143                | 53.2               | LOS E            | 0.5                   | 0.5         | 0.93      | 0.93           | 69.9               | 20.0              | 0.29                 |
| All Pedestrians                 |          | 725                | 51.3               | LOS E            | 0.9                   | 0.9         | 0.91      | 0.91           | 68.0               | 20.0              | 0.29                 |

Level of Service (LOS) Method: SIDRA Pedestrian LOS Method (Based on Average Delay)

Pedestrian movement LOS values are based on average delay per pedestrian movement.

Intersection LOS value for Pedestrians is based on average delay for all pedestrian movements.

**SIDRA INTERSECTION 9.1 | Copyright © 2000-2022 Akcelik and Associates Pty Ltd | sidrasolutions.com**

Organisation: AECOM AUSTRALIA PTY LTD | Licence: NETWORK / Enterprise Level 1 | Processed: Monday, 17 July 2023 1:41:32 PM

Project: C:\Users\YeungMA\AECOM\ANZ-NAC-Sydney Metro-Sydney Metro C&SW Operational Monitoring - General\400\_Technical\432\_Traffic Analysis\SIDRA Modelling\01 Models (Geometry Only)\Block 1\Rev1\_Review\02 SM C&SW\_CST (Block 1)\_PS.sip9

# MOVEMENT SUMMARY

Site: CST05 [CST05 Clarke St / Oxley St (Site Folder: Block 1 Model - 2023 PM Peak)]

Output produced by SIDRA INTERSECTION Version: 9.1.1.200

Network: CST-N1 [CST Network 1 (Network Folder: Block 1 Network - 2023 PM Peak)]

NA  
 Site Category: (None)  
 Give-Way (Two-Way)

| Vehicle Movement Performance |      |           |                       |     |                       |     |           |             |                  |                   |               |           |                |                     |                  |
|------------------------------|------|-----------|-----------------------|-----|-----------------------|-----|-----------|-------------|------------------|-------------------|---------------|-----------|----------------|---------------------|------------------|
| Mov ID                       | Turn | Mov Class | Demand Flows          |     | Arrival Flows         |     | Deg. Satn | Aver. Delay | Level of Service | 95% Back Of Queue |               | Prop. Que | Eff. Stop Rate | Aver. No. of Cycles | Aver. Speed km/h |
|                              |      |           | [ Total HV ]<br>veh/h | %   | [ Total HV ]<br>veh/h | %   |           |             |                  | [ Veh. veh        | [ Dist ]<br>m |           |                |                     |                  |
| SouthEast: Clarke St (SE)    |      |           |                       |     |                       |     |           |             |                  |                   |               |           |                |                     |                  |
| 1                            | L2   | All MCs   | 53                    | 0.0 | 53                    | 0.0 | 0.109     | 5.1         | LOSA             | 0.4               | 2.7           | 0.36      | 0.58           | 0.36                | 32.0             |
| 3a                           | R1   | All MCs   | 55                    | 0.0 | 55                    | 0.0 | 0.109     | 6.4         | LOSA             | 0.4               | 2.7           | 0.36      | 0.58           | 0.36                | 32.0             |
| Approach                     |      |           | 107                   | 0.0 | 107                   | 0.0 | 0.109     | 5.8         | LOSA             | 0.4               | 2.7           | 0.36      | 0.58           | 0.36                | 32.0             |
| North: Oxley St (N)          |      |           |                       |     |                       |     |           |             |                  |                   |               |           |                |                     |                  |
| 24a                          | L1   | All MCs   | 164                   | 0.6 | 164                   | 0.6 | 0.185     | 4.4         | LOSA             | 0.0               | 0.0           | 0.00      | 0.53           | 0.00                | 29.5             |
| 26a                          | R1   | All MCs   | 179                   | 0.0 | 179                   | 0.0 | 0.185     | 4.1         | LOSA             | 0.0               | 0.0           | 0.00      | 0.53           | 0.00                | 29.5             |
| Approach                     |      |           | 343                   | 0.3 | 343                   | 0.3 | 0.185     | 4.2         | NA               | 0.0               | 0.0           | 0.00      | 0.53           | 0.00                | 29.5             |
| SouthWest: Oxley St (SW)     |      |           |                       |     |                       |     |           |             |                  |                   |               |           |                |                     |                  |
| 10a                          | L1   | All MCs   | 165                   | 0.0 | 165                   | 0.0 | 0.149     | 2.8         | LOSA             | 0.6               | 4.1           | 0.30      | 0.57           | 0.30                | 21.9             |
| 12                           | R2   | All MCs   | 80                    | 0.0 | 80                    | 0.0 | 0.149     | 5.6         | LOSA             | 0.6               | 4.1           | 0.30      | 0.57           | 0.30                | 21.9             |
| Approach                     |      |           | 245                   | 0.0 | 245                   | 0.0 | 0.149     | 3.7         | NA               | 0.6               | 4.1           | 0.30      | 0.57           | 0.30                | 21.9             |
| All Vehicles                 |      |           | 696                   | 0.2 | 696                   | 0.2 | 0.185     | 4.3         | NA               | 0.6               | 4.1           | 0.16      | 0.55           | 0.16                | 28.4             |

Site Level of Service (LOS) Method: Delay (RTA NSW). Site LOS Method is specified in the Network Data dialog (Override Site Data tab).

Vehicle movement LOS values are based on average delay per movement.

Minor Road Approach LOS values are based on average delay for all vehicle movements.

NA (TWSC): Level of Service is not defined for major road approaches or the intersection as a whole for Two-Way Sign Control (HCM LOS rule).

Two-Way Sign Control Capacity Model: SIDRA Standard.

Delay Model: SIDRA Standard (Control Delay: Geometric Delay is included).

Queue Model: SIDRA queue estimation methods are used for Back of Queue and Queue at Start of Gap.

Gap-Acceptance Capacity Formula: SIDRA Standard (Akçelik M3D).

HV (%) values are calculated for All Movement Classes of All Heavy Vehicle Model Designation.

Arrival Flows used in performance calculations are adjusted to include any Initial Queued Demand and Upstream Capacity Constraint effects.

---

**SIDRA INTERSECTION 9.1 | Copyright © 2000-2022 Akcelik and Associates Pty Ltd | sidrasolutions.com**

Organisation: AECOM AUSTRALIA PTY LTD | Licence: NETWORK / Enterprise Level 1 | Processed: Monday, 17 July 2023 1:41:32 PM

Project: C:\Users\Yeung\AECOM\ANZ-NAC-Sydney Metro-Sydney Metro C&SW Operational Monitoring - General\400\_Technical\432\_Traffic Analysis\SIDRA Modelling\01 Models (Geometry Only)\Block 1\Rev1\\_Review\02 SM C&SW\_CST (Block 1)\_PS.sip9

# MOVEMENT SUMMARY

Site: CST06 [CST06 Clarke St / Hume St (Site Folder: Block 1 Model - 2023 PM Peak)]

Output produced by SIDRA INTERSECTION Version: 9.1.1.200

Network: CST-N1 [CST Network 1 (Network Folder: Block 1 Network - 2023 PM Peak)]

NA  
 Site Category: (None)  
 Give-Way (Two-Way)

| Vehicle Movement Performance |      |           |                       |     |                       |     |           |             |                  |                   |               |           |                |                     |                  |
|------------------------------|------|-----------|-----------------------|-----|-----------------------|-----|-----------|-------------|------------------|-------------------|---------------|-----------|----------------|---------------------|------------------|
| Mov ID                       | Turn | Mov Class | Demand Flows          |     | Arrival Flows         |     | Deg. Satn | Aver. Delay | Level of Service | 95% Back Of Queue |               | Prop. Que | Eff. Stop Rate | Aver. No. of Cycles | Aver. Speed km/h |
|                              |      |           | [ Total HV ]<br>veh/h | %   | [ Total HV ]<br>veh/h | %   |           |             |                  | [ Veh. veh        | [ Dist ]<br>m |           |                |                     |                  |
| SouthEast: Clarke St (SE)    |      |           |                       |     |                       |     |           |             |                  |                   |               |           |                |                     |                  |
| 1                            | L2   | All MCs   | 1                     | 0.0 | 1                     | 0.0 | 0.062     | 4.6         | LOS A            | 0.0               | 0.0           | 0.00      | 0.00           | 0.00                | 49.7             |
| 2                            | T1   | All MCs   | 119                   | 0.0 | 119                   | 0.0 | 0.062     | 0.0         | LOS A            | 0.0               | 0.0           | 0.00      | 0.00           | 0.00                | 49.7             |
| Approach                     |      |           | 120                   | 0.0 | 120                   | 0.0 | 0.062     | 0.0         | NA               | 0.0               | 0.0           | 0.00      | 0.00           | 0.00                | 49.7             |
| NorthWest: Clarke St (NW)    |      |           |                       |     |                       |     |           |             |                  |                   |               |           |                |                     |                  |
| 8                            | T1   | All MCs   | 239                   | 0.4 | 239                   | 0.4 | 0.124     | 0.0         | LOS A            | 0.0               | 0.1           | 0.01      | 0.01           | 0.01                | 49.8             |
| 9                            | R2   | All MCs   | 2                     | 0.0 | 2                     | 0.0 | 0.124     | 4.7         | LOS A            | 0.0               | 0.1           | 0.01      | 0.01           | 0.01                | 49.7             |
| Approach                     |      |           | 241                   | 0.4 | 241                   | 0.4 | 0.124     | 0.0         | NA               | 0.0               | 0.1           | 0.01      | 0.01           | 0.01                | 49.8             |
| SouthWest: Hume St (SW)      |      |           |                       |     |                       |     |           |             |                  |                   |               |           |                |                     |                  |
| 10                           | L2   | All MCs   | 17                    | 0.0 | 17                    | 0.0 | 0.034     | 3.5         | LOS A            | 0.1               | 0.4           | 0.23      | 0.50           | 0.23                | 23.9             |
| 12                           | R2   | All MCs   | 5                     | 0.0 | 5                     | 0.0 | 0.034     | 4.5         | LOS A            | 0.1               | 0.4           | 0.23      | 0.50           | 0.23                | 31.9             |
| Approach                     |      |           | 22                    | 0.0 | 22                    | 0.0 | 0.034     | 3.8         | LOS A            | 0.1               | 0.4           | 0.23      | 0.50           | 0.23                | 27.2             |
| All Vehicles                 |      |           | 383                   | 0.3 | 383                   | 0.3 | 0.124     | 0.3         | NA               | 0.1               | 0.4           | 0.02      | 0.03           | 0.02                | 48.9             |

Site Level of Service (LOS) Method: Delay (RTA NSW). Site LOS Method is specified in the Network Data dialog (Override Site Data tab).

Vehicle movement LOS values are based on average delay per movement.

Minor Road Approach LOS values are based on average delay for all vehicle movements.

NA (TWSC): Level of Service is not defined for major road approaches or the intersection as a whole for Two-Way Sign Control (HCM LOS rule).

Two-Way Sign Control Capacity Model: SIDRA Standard.

Delay Model: SIDRA Standard (Control Delay: Geometric Delay is included).

Queue Model: SIDRA queue estimation methods are used for Back of Queue and Queue at Start of Gap.

Gap-Acceptance Capacity Formula: SIDRA Standard (Akçelik M3D).

HV (%) values are calculated for All Movement Classes of All Heavy Vehicle Model Designation.

Arrival Flows used in performance calculations are adjusted to include any Initial Queued Demand and Upstream Capacity Constraint effects.



---

**SIDRA INTERSECTION 9.1 | Copyright © 2000-2022 Akcelik and Associates Pty Ltd | sidrasolutions.com**

Organisation: AECOM AUSTRALIA PTY LTD | Licence: NETWORK / Enterprise Level 1 | Processed: Monday, 17 July 2023 1:41:32 PM

Project: C:\Users\Yeung\AECOM\ANZ-NAC-Sydney Metro-Sydney Metro C&SW Operational Monitoring - General\400\_Technical\432\_Traffic Analysis\SIDRA Modelling\01 Models (Geometry Only)\Block 1\Rev1\\_Review\02 SM C&SW\_CST (Block 1)\_PS.sip9

# MOVEMENT SUMMARY

Site: CST07 [CST07 Clarke St / Willoughby Rd (Site Folder: Block 1 Model - 2023 PM Peak)]

Output produced by SIDRA INTERSECTION Version: 9.1.1.200

NA

Site Category: (None)

Give-Way (Two-Way)

| Vehicle Movement Performance |      |           |              |      |               |      |           |             |                  |                   |          |           |                |                     |             |
|------------------------------|------|-----------|--------------|------|---------------|------|-----------|-------------|------------------|-------------------|----------|-----------|----------------|---------------------|-------------|
| Mov ID                       | Turn | Mov Class | Demand Flows |      | Arrival Flows |      | Deg. Satn | Aver. Delay | Level of Service | 95% Back Of Queue |          | Prop. Que | Eff. Stop Rate | Aver. No. of Cycles | Aver. Speed |
|                              |      |           | [ Total HV ] | %    | [ Total HV ]  | %    | v/c       | sec         |                  | [ Veh. ]          | [ Dist ] |           |                |                     | km/h        |
|                              |      |           | veh/h        |      | veh/h         |      |           |             |                  | veh               | m        |           |                |                     |             |
| South: Willoughby Rd (S)     |      |           |              |      |               |      |           |             |                  |                   |          |           |                |                     |             |
| 1                            | L2   | All MCs   | 95           | 0.0  | 95            | 0.0  | 0.230     | 4.1         | LOS A            | 1.1               | 8.3      | 0.43      | 0.40           | 0.43                | 30.2        |
| 2                            | T1   | All MCs   | 114          | 12.0 | 114           | 12.0 | 0.230     | 3.1         | LOS A            | 1.1               | 8.3      | 0.43      | 0.40           | 0.43                | 35.2        |
| Approach                     |      |           | 208          | 6.6  | 208           | 6.6  | 0.230     | 3.6         | NA               | 1.1               | 8.3      | 0.43      | 0.40           | 0.43                | 33.4        |
| North: Willoughby Rd (N)     |      |           |              |      |               |      |           |             |                  |                   |          |           |                |                     |             |
| 8                            | T1   | All MCs   | 174          | 4.2  | 174           | 4.2  | 0.293     | 2.9         | LOS A            | 1.3               | 9.2      | 0.48      | 0.47           | 0.48                | 34.6        |
| 9                            | R2   | All MCs   | 59           | 0.0  | 59            | 0.0  | 0.293     | 7.9         | LOS A            | 1.3               | 9.2      | 0.48      | 0.47           | 0.48                | 33.9        |
| Approach                     |      |           | 233          | 3.2  | 233           | 3.2  | 0.293     | 4.1         | NA               | 1.3               | 9.2      | 0.48      | 0.47           | 0.48                | 34.4        |
| West: Clarke St (W)          |      |           |              |      |               |      |           |             |                  |                   |          |           |                |                     |             |
| 10                           | L2   | All MCs   | 86           | 0.0  | 86            | 0.0  | 0.198     | 6.2         | LOS A            | 0.7               | 5.2      | 0.52      | 0.71           | 0.52                | 32.5        |
| 12                           | R2   | All MCs   | 79           | 0.0  | 79            | 0.0  | 0.198     | 6.2         | LOS A            | 0.7               | 5.2      | 0.52      | 0.71           | 0.52                | 26.4        |
| Approach                     |      |           | 165          | 0.0  | 165           | 0.0  | 0.198     | 6.2         | LOS A            | 0.7               | 5.2      | 0.52      | 0.71           | 0.52                | 30.3        |
| All Vehicles                 |      |           | 606          | 3.5  | 606           | 3.5  | 0.293     | 4.5         | NA               | 1.3               | 9.2      | 0.47      | 0.51           | 0.47                | 33.0        |

Site Level of Service (LOS) Method: Delay (RTA NSW). Site LOS Method is specified in the Parameter Settings dialog (Options tab).

Vehicle movement LOS values are based on average delay per movement.

Minor Road Approach LOS values are based on average delay for all vehicle movements.

NA (TWSC): Level of Service is not defined for major road approaches or the intersection as a whole for Two-Way Sign Control (HCM LOS rule).

Two-Way Sign Control Capacity Model: SIDRA Standard.

Delay Model: SIDRA Standard (Control Delay: Geometric Delay is included).

Queue Model: SIDRA queue estimation methods are used for Back of Queue and Queue at Start of Gap.

Gap-Acceptance Capacity Formula: SIDRA Standard (Akçelik M3D).

HV (%) values are calculated for All Movement Classes of All Heavy Vehicle Model Designation.

Arrival Flows used in performance calculations are adjusted to include any Initial Queued Demand and Upstream Capacity Constraint effects.

---

**SIDRA INTERSECTION 9.1 | Copyright © 2000-2022 Akcelik and Associates Pty Ltd | sidrasolutions.com**

Organisation: AECOM AUSTRALIA PTY LTD | Licence: NETWORK / Enterprise Level 1 | Processed: Thursday, 13 July 2023 6:24:35 PM

Project: C:\Users\Yeung\AECOM\ANZ-NAC-Sydney Metro-Sydney Metro C&SW Operational Monitoring - General\400\_Technical\432\_Traffic Analysis\SIDRA Modelling\01 Models (Geometry Only)\Block 1\Rev1\\_Review\02 SM C&SW\_CST (Block 1)\_PS.sip9

# MOVEMENT SUMMARY

**Site: CST08 [CST08 Albany St / Willoughby Rd (Site Folder: Block 1 Model - 2023 PM Peak)]**

**Output produced by SIDRA INTERSECTION Version: 9.1.1.200**

TCS 516

Site Category: (None)

Signals - EQUISAT (Fixed-Time/SCATS) Isolated Cycle Time = 80 seconds (Site User-Given Phase Times)

| Vehicle Movement Performance |      |           |              |      |               |      |           |             |                  |                   |          |           |                |                     |             |
|------------------------------|------|-----------|--------------|------|---------------|------|-----------|-------------|------------------|-------------------|----------|-----------|----------------|---------------------|-------------|
| Mov ID                       | Turn | Mov Class | Demand Flows |      | Arrival Flows |      | Deg. Satn | Aver. Delay | Level of Service | 95% Back Of Queue |          | Prop. Que | Eff. Stop Rate | Aver. No. of Cycles | Aver. Speed |
|                              |      |           | [ Total HV ] | %    | [ Total HV ]  | %    | v/c       | sec         |                  | [ Veh. ]          | [ Dist ] |           |                |                     | km/h        |
|                              |      |           | veh/h        |      | veh/h         |      |           |             |                  | veh               | m        |           |                |                     |             |
| South: Willoughby Rd (S)     |      |           |              |      |               |      |           |             |                  |                   |          |           |                |                     |             |
| 1                            | L2   | All MCs   | 64           | 18.0 | 64            | 18.0 | 0.174     | 39.4        | LOS C            | 2.0               | 16.5     | 0.83      | 0.72           | 0.83                | 21.8        |
| 2                            | T1   | All MCs   | 132          | 4.0  | 132           | 4.0  | 0.323     | 33.2        | LOS C            | 4.4               | 31.4     | 0.82      | 0.68           | 0.82                | 25.6        |
| 3                            | R2   | All MCs   | 11           | 0.0  | 11            | 0.0  | 0.323     | 42.1        | LOS C            | 4.4               | 31.4     | 0.82      | 0.68           | 0.82                | 24.2        |
| Approach                     |      |           | 206          | 8.2  | 206           | 8.2  | 0.323     | 35.6        | LOS C            | 4.4               | 31.4     | 0.82      | 0.69           | 0.82                | 24.3        |
| East: Albany St (E)          |      |           |              |      |               |      |           |             |                  |                   |          |           |                |                     |             |
| 4                            | L2   | All MCs   | 21           | 0.0  | 21            | 0.0  | 0.240     | 16.1        | LOS B            | 5.0               | 35.5     | 0.54      | 0.48           | 0.54                | 32.7        |
| 5                            | T1   | All MCs   | 306          | 0.7  | 306           | 0.7  | 0.480     | 10.0        | LOS A            | 6.5               | 45.9     | 0.60      | 0.54           | 0.60                | 32.7        |
| 6                            | R2   | All MCs   | 169          | 0.6  | 169           | 0.6  | *0.480    | 23.0        | LOS B            | 6.5               | 45.9     | 0.79      | 0.75           | 0.79                | 26.4        |
| Approach                     |      |           | 497          | 0.6  | 497           | 0.6  | 0.480     | 14.7        | LOS B            | 6.5               | 45.9     | 0.66      | 0.61           | 0.66                | 30.2        |
| North: Willoughby Rd (N)     |      |           |              |      |               |      |           |             |                  |                   |          |           |                |                     |             |
| 7                            | L2   | All MCs   | 124          | 0.0  | 124           | 0.0  | 0.167     | 21.2        | LOS B            | 3.1               | 21.8     | 0.68      | 0.72           | 0.68                | 25.6        |
| 8                            | T1   | All MCs   | 153          | 2.8  | 153           | 2.8  | 0.371     | 25.1        | LOS B            | 5.8               | 41.7     | 0.84      | 0.74           | 0.84                | 24.5        |
| 9                            | R2   | All MCs   | 32           | 0.0  | 32            | 0.0  | *0.371    | 34.8        | LOS C            | 5.8               | 41.7     | 0.84      | 0.74           | 0.84                | 22.9        |
| Approach                     |      |           | 308          | 1.4  | 308           | 1.4  | 0.371     | 24.5        | LOS B            | 5.8               | 41.7     | 0.78      | 0.73           | 0.78                | 24.7        |
| West: Albany St (W)          |      |           |              |      |               |      |           |             |                  |                   |          |           |                |                     |             |
| 10                           | L2   | All MCs   | 116          | 0.9  | 116           | 0.9  | 0.162     | 21.8        | LOS B            | 3.0               | 20.8     | 0.69      | 0.72           | 0.69                | 25.3        |
| 11                           | T1   | All MCs   | 343          | 0.0  | 343           | 0.0  | *0.391    | 15.8        | LOS B            | 8.9               | 62.6     | 0.71      | 0.61           | 0.71                | 29.5        |
| Approach                     |      |           | 459          | 0.2  | 459           | 0.2  | 0.391     | 17.3        | LOS B            | 8.9               | 62.6     | 0.71      | 0.64           | 0.71                | 28.3        |
| All Vehicles                 |      |           | 1471         | 1.7  | 1471          | 1.7  | 0.480     | 20.5        | LOS B            | 8.9               | 62.6     | 0.72      | 0.66           | 0.72                | 27.2        |

Site Level of Service (LOS) Method: Delay (RTA NSW). Site LOS Method is specified in the Parameter Settings dialog (Options tab).

Vehicle movement LOS values are based on average delay per movement.

Intersection and Approach LOS values are based on average delay for all vehicle movements.

Delay Model: SIDRA Standard (Control Delay: Geometric Delay is included).

Queue Model: SIDRA queue estimation methods are used for Back of Queue and Queue at Start of Green.

Gap-Acceptance Capacity Formula: SIDRA Standard (Akçelik M3D).

HV (%) values are calculated for All Movement Classes of All Heavy Vehicle Model Designation.

Arrival Flows used in performance calculations are adjusted to include any Initial Queued Demand and Upstream Capacity Constraint effects.

\* Critical Movement (Signal Timing)

| Pedestrian Movement Performance |          |            |           |             |                  |                       |        |           |                |             |              |             |
|---------------------------------|----------|------------|-----------|-------------|------------------|-----------------------|--------|-----------|----------------|-------------|--------------|-------------|
| Mov ID                          | Crossing | Input Vol. | Dem. Flow | Aver. Delay | Level of Service | AVERAGE BACK OF QUEUE |        | Prop. Que | Eff. Stop Rate | Travel Time | Travel Dist. | Aver. Speed |
|                                 |          | ped/h      | ped/h     | sec         |                  | [ Ped                 | Dist ] |           |                | sec         | m            | m/sec       |
|                                 |          |            |           |             |                  | ped                   | m      |           |                |             |              |             |
| South: Willoughby Rd (S)        |          |            |           |             |                  |                       |        |           |                |             |              |             |
| P1                              | Full     | 85         | 89        | 29.9        | LOS C            | 0.2                   | 0.2    | 0.87      | 0.87           | 46.5        | 20.0         | 0.43        |
| East: Albany St (E)             |          |            |           |             |                  |                       |        |           |                |             |              |             |
| P2                              | Full     | 231        | 243       | 30.1        | LOS D            | 0.5                   | 0.5    | 0.87      | 0.87           | 46.7        | 20.0         | 0.43        |
| North: Willoughby Rd (N)        |          |            |           |             |                  |                       |        |           |                |             |              |             |
| P3                              | Full     | 129        | 136       | 29.9        | LOS C            | 0.3                   | 0.3    | 0.87      | 0.87           | 46.6        | 20.0         | 0.43        |
| West: Albany St (W)             |          |            |           |             |                  |                       |        |           |                |             |              |             |
| P4                              | Full     | 150        | 158       | 30.0        | LOS C            | 0.3                   | 0.3    | 0.87      | 0.87           | 46.6        | 20.0         | 0.43        |
| All Pedestrians                 |          | 595        | 626       | 30.0        | LOS C            | 0.5                   | 0.5    | 0.87      | 0.87           | 46.6        | 20.0         | 0.43        |

Level of Service (LOS) Method: SIDRA Pedestrian LOS Method (Based on Average Delay)

Pedestrian movement LOS values are based on average delay per pedestrian movement.

Intersection LOS value for Pedestrians is based on average delay for all pedestrian movements.

**SIDRA INTERSECTION 9.1 | Copyright © 2000-2022 Kcelik and Associates Pty Ltd | sidrasolutions.com**

Organisation: AECOM AUSTRALIA PTY LTD | Licence: NETWORK / Enterprise Level 1 | Processed: Thursday, 13 July 2023 6:24:36 PM

Project: C:\Users\YeungM\AECOM\ANZ-NAC-Sydney Metro-Sydney Metro C&SW Operational Monitoring - General\400\_Technical\432\_Traffic Analysis\SIDRA Modelling\01 Models (Geometry Only)\Block 1\Rev1\Review\02 SM C&SW\_CST (Block 1)\_PS.sip9

# MOVEMENT SUMMARY

Site: CST09 [CST09 Albany St / Oxley St (Site Folder: Block 1 Model - 2023 PM Peak)]

Output produced by SIDRA INTERSECTION Version: 9.1.1.200

Network: CST-N1 [CST Network 1 (Network Folder: Block 1 Network - 2023 PM Peak)]

NA  
Site Category: (None)  
Roundabout

| Vehicle Movement Performance |      |           |                       |     |                       |     |           |             |                  |                   |               |           |                |                     |                  |
|------------------------------|------|-----------|-----------------------|-----|-----------------------|-----|-----------|-------------|------------------|-------------------|---------------|-----------|----------------|---------------------|------------------|
| Mov ID                       | Turn | Mov Class | Demand Flows          |     | Arrival Flows         |     | Deg. Satn | Aver. Delay | Level of Service | 95% Back Of Queue |               | Prop. Que | Eff. Stop Rate | Aver. No. of Cycles | Aver. Speed km/h |
|                              |      |           | [ Total HV ]<br>veh/h | %   | [ Total HV ]<br>veh/h | %   |           |             |                  | [ Veh. veh        | [ Dist ]<br>m |           |                |                     |                  |
| South: Oxley St (S)          |      |           |                       |     |                       |     |           |             |                  |                   |               |           |                |                     |                  |
| 1                            | L2   | All MCs   | 61                    | 0.0 | 61                    | 0.0 | 0.457     | 9.5         | LOS A            | 3.3               | 23.2          | 0.85      | 0.75           | 0.92                | 19.9             |
| 2                            | T1   | All MCs   | 147                   | 0.7 | 147                   | 0.7 | 0.457     | 9.4         | LOS A            | 3.3               | 23.2          | 0.85      | 0.75           | 0.92                | 31.3             |
| 3                            | R2   | All MCs   | 73                    | 0.0 | 73                    | 0.0 | 0.457     | 12.2        | LOS A            | 3.3               | 23.2          | 0.85      | 0.75           | 0.92                | 29.5             |
| 3u                           | U    | All MCs   | 2                     | 0.0 | 2                     | 0.0 | 0.457     | 13.6        | LOS A            | 3.3               | 23.2          | 0.85      | 0.75           | 0.92                | 19.9             |
| Approach                     |      |           | 283                   | 0.4 | 283                   | 0.4 | 0.457     | 10.2        | LOS A            | 3.3               | 23.2          | 0.85      | 0.75           | 0.92                | 29.2             |
| East: Albany St (E)          |      |           |                       |     |                       |     |           |             |                  |                   |               |           |                |                     |                  |
| 4                            | L2   | All MCs   | 38                    | 0.0 | 38                    | 0.0 | 0.882     | 15.9        | LOS B            | 8.9               | 63.3          | 0.93      | 1.09           | 1.38                | 21.8             |
| 5                            | T1   | All MCs   | 382                   | 2.5 | 382                   | 2.5 | 0.882     | 15.9        | LOS B            | 8.9               | 63.3          | 0.93      | 1.09           | 1.38                | 21.8             |
| 6                            | R2   | All MCs   | 27                    | 0.0 | 27                    | 0.0 | 0.882     | 18.6        | LOS B            | 8.9               | 63.3          | 0.93      | 1.09           | 1.38                | 28.9             |
| 6u                           | U    | All MCs   | 4                     | 0.0 | 4                     | 0.0 | 0.882     | 20.0        | LOS B            | 8.9               | 63.3          | 0.93      | 1.09           | 1.38                | 28.1             |
| Approach                     |      |           | 452                   | 2.1 | 452                   | 2.1 | 0.882     | 16.1        | LOS B            | 8.9               | 63.3          | 0.93      | 1.09           | 1.38                | 22.5             |
| North: Oxley St (N)          |      |           |                       |     |                       |     |           |             |                  |                   |               |           |                |                     |                  |
| 7                            | L2   | All MCs   | 18                    | 0.0 | 18                    | 0.0 | 0.429     | 9.7         | LOS A            | 2.9               | 20.7          | 0.85      | 0.76           | 0.90                | 33.4             |
| 8                            | T1   | All MCs   | 140                   | 0.0 | 140                   | 0.0 | 0.429     | 9.5         | LOS A            | 2.9               | 20.7          | 0.85      | 0.76           | 0.90                | 28.4             |
| 9                            | R2   | All MCs   | 97                    | 2.2 | 97                    | 2.2 | 0.429     | 12.5        | LOS A            | 2.9               | 20.7          | 0.85      | 0.76           | 0.90                | 28.4             |
| 9u                           | U    | All MCs   | 1                     | 0.0 | 1                     | 0.0 | 0.429     | 13.8        | LOS A            | 2.9               | 20.7          | 0.85      | 0.76           | 0.90                | 33.7             |
| Approach                     |      |           | 256                   | 0.8 | 256                   | 0.8 | 0.429     | 10.7        | LOS A            | 2.9               | 20.7          | 0.85      | 0.76           | 0.90                | 29.0             |
| West: Albany St (W)          |      |           |                       |     |                       |     |           |             |                  |                   |               |           |                |                     |                  |
| 10                           | L2   | All MCs   | 113                   | 0.0 | 113                   | 0.0 | 0.613     | 7.3         | LOS A            | 6.3               | 44.0          | 0.79      | 0.63           | 0.82                | 34.0             |
| 11                           | T1   | All MCs   | 377                   | 0.3 | 377                   | 0.3 | 0.613     | 7.1         | LOS A            | 6.3               | 44.0          | 0.79      | 0.63           | 0.82                | 33.7             |
| 12                           | R2   | All MCs   | 102                   | 0.0 | 102                   | 0.0 | 0.613     | 10.0        | LOS A            | 6.3               | 44.0          | 0.79      | 0.63           | 0.82                | 25.3             |
| 12u                          | U    | All MCs   | 4                     | 0.0 | 4                     | 0.0 | 0.613     | 11.4        | LOS A            | 6.3               | 44.0          | 0.79      | 0.63           | 0.82                | 25.3             |
| Approach                     |      |           | 596                   | 0.2 | 596                   | 0.2 | 0.613     | 7.7         | LOS A            | 6.3               | 44.0          | 0.79      | 0.63           | 0.82                | 32.9             |
| All Vehicles                 |      |           | 1586                  | 0.9 | 1586                  | 0.9 | 0.882     | 11.0        | LOS A            | 8.9               | 63.3          | 0.85      | 0.80           | 1.01                | 28.5             |

Site Level of Service (LOS) Method: Delay (RTA NSW). Site LOS Method is specified in the Network Data dialog (Override Site Data tab).

Vehicle movement LOS values are based on average delay per movement.

Intersection and Approach LOS values are based on average delay for all vehicle movements.

Roundabout Capacity Model: SIDRA Standard.

Delay Model: SIDRA Standard (Control Delay: Geometric Delay is included).

Queue Model: SIDRA queue estimation methods are used for Back of Queue and Queue at Start of Gap.

Gap-Acceptance Capacity Formula: SIDRA Standard (Akçelik M3D).

HV (%) values are calculated for All Movement Classes of All Heavy Vehicle Model Designation.

Arrival Flows used in performance calculations are adjusted to include any Initial Queued Demand and Upstream Capacity Constraint effects.

---

**SIDRA INTERSECTION 9.1 | Copyright © 2000-2022 Akcelik and Associates Pty Ltd | sidrasolutions.com**

Organisation: AECOM AUSTRALIA PTY LTD | Licence: NETWORK / Enterprise Level 1 | Processed: Monday, 17 July 2023 1:41:32 PM

Project: C:\Users\Yeung\AECOM\ANZ-NAC-Sydney Metro-Sydney Metro C&SW Operational Monitoring - General\400\_Technical\432\_Traffic Analysis\SIDRA Modelling\01 Models (Geometry Only)\Block 1\Rev1\\_Review\02 SM C&SW\_CST (Block 1)\_PS.sip9



# MOVEMENT SUMMARY

Site: CST10 [CST10 Albany St / Clarke Ln (Site Folder: Block 1 Model - 2023 PM Peak)]

Output produced by SIDRA INTERSECTION Version: 9.1.1.200

Network: CST-N1 [CST Network 1 (Network Folder: Block 1 Network - 2023 PM Peak)]

NA  
 Site Category: (None)  
 Give-Way (Two-Way)

| Vehicle Movement Performance |      |           |                       |     |                       |     |           |             |                  |                   |               |           |                |                     |                  |
|------------------------------|------|-----------|-----------------------|-----|-----------------------|-----|-----------|-------------|------------------|-------------------|---------------|-----------|----------------|---------------------|------------------|
| Mov ID                       | Turn | Mov Class | Demand Flows          |     | Arrival Flows         |     | Deg. Satn | Aver. Delay | Level of Service | 95% Back Of Queue |               | Prop. Que | Eff. Stop Rate | Aver. No. of Cycles | Aver. Speed km/h |
|                              |      |           | [ Total HV ]<br>veh/h | %   | [ Total HV ]<br>veh/h | %   |           |             |                  | [ Veh. veh        | [ Dist ]<br>m |           |                |                     |                  |
| SouthEast: Clarke Ln (SE)    |      |           |                       |     |                       |     |           |             |                  |                   |               |           |                |                     |                  |
| 21a                          | L1   | All MCs   | 38                    | 0.0 | 38                    | 0.0 | 0.081     | 5.0         | LOS A            | 2.3               | 15.8          | 0.42      | 0.59           | 0.42                | 30.8             |
| 23b                          | R3   | All MCs   | 4                     | 0.0 | 4                     | 0.0 | 0.081     | 15.9        | LOS B            | 2.3               | 15.8          | 0.42      | 0.59           | 0.42                | 30.8             |
| Approach                     |      |           | 42                    | 0.0 | 42                    | 0.0 | 0.081     | 6.1         | LOS A            | 2.3               | 15.8          | 0.42      | 0.59           | 0.42                | 30.8             |
| East: Albany St (E)          |      |           |                       |     |                       |     |           |             |                  |                   |               |           |                |                     |                  |
| 5                            | T1   | All MCs   | 544                   | 2.1 | 544                   | 2.1 | 0.143     | 0.0         | LOS A            | 14.0              | 99.8          | 0.00      | 0.00           | 0.00                | 49.9             |
| Approach                     |      |           | 544                   | 2.1 | 544                   | 2.1 | 0.143     | 0.0         | NA               | 14.0              | 99.8          | 0.00      | 0.00           | 0.00                | 49.9             |
| West: Albany St (W)          |      |           |                       |     |                       |     |           |             |                  |                   |               |           |                |                     |                  |
| 11                           | T1   | All MCs   | 558                   | 0.2 | 558                   | 0.2 | 0.287     | 0.0         | LOS A            | 0.0               | 0.0           | 0.00      | 0.00           | 0.00                | 49.9             |
| Approach                     |      |           | 558                   | 0.2 | 558                   | 0.2 | 0.287     | 0.0         | NA               | 0.0               | 0.0           | 0.00      | 0.00           | 0.00                | 49.9             |
| All Vehicles                 |      |           | 1144                  | 1.1 | 1144                  | 1.1 | 0.287     | 0.2         | NA               | 14.0              | 99.8          | 0.02      | 0.02           | 0.02                | 47.9             |

Site Level of Service (LOS) Method: Delay (RTA NSW). Site LOS Method is specified in the Network Data dialog (Override Site Data tab).

Vehicle movement LOS values are based on average delay per movement.

Minor Road Approach LOS values are based on average delay for all vehicle movements.

NA (TWSC): Level of Service is not defined for major road approaches or the intersection as a whole for Two-Way Sign Control (HCM LOS rule).

Two-Way Sign Control Capacity Model: SIDRA Standard.

Delay Model: SIDRA Standard (Control Delay: Geometric Delay is included).

Queue Model: SIDRA queue estimation methods are used for Back of Queue and Queue at Start of Gap.

Gap-Acceptance Capacity Formula: SIDRA Standard (Akçelik M3D).

HV (%) values are calculated for All Movement Classes of All Heavy Vehicle Model Designation.

Arrival Flows used in performance calculations are adjusted to include any Initial Queued Demand and Upstream Capacity Constraint effects.

---

**SIDRA INTERSECTION 9.1 | Copyright © 2000-2022 Akcelik and Associates Pty Ltd | sidrasolutions.com**

Organisation: AECOM AUSTRALIA PTY LTD | Licence: NETWORK / Enterprise Level 1 | Processed: Monday, 17 July 2023 1:41:32 PM

Project: C:\Users\Yeung\AECOM\ANZ-NAC-Sydney Metro-Sydney Metro C&SW Operational Monitoring - General\400\_Technical\432\_Traffic Analysis\SIDRA Modelling\01 Models (Geometry Only)\Block 1\Rev1\\_Review\02 SM C&SW\_CST (Block 1)\_PS.sip9

# MOVEMENT SUMMARY

Site: CST11 [CST11 Oxley St / Clarke Ln (Site Folder: Block 1 Model - 2023 PM Peak)]

Output produced by SIDRA INTERSECTION Version: 9.1.1.200

Network: CST-N1 [CST Network 1 (Network Folder: Block 1 Network - 2023 PM Peak)]

NA  
Site Category: (None)  
Give-Way (Two-Way)

| Vehicle Movement Performance |      |           |                       |     |                       |     |           |             |                  |                   |             |           |                |                     |                  |
|------------------------------|------|-----------|-----------------------|-----|-----------------------|-----|-----------|-------------|------------------|-------------------|-------------|-----------|----------------|---------------------|------------------|
| Mov ID                       | Turn | Mov Class | Demand Flows          |     | Arrival Flows         |     | Deg. Satn | Aver. Delay | Level of Service | 95% Back Of Queue |             | Prop. Que | Eff. Stop Rate | Aver. No. of Cycles | Aver. Speed km/h |
|                              |      |           | [ Total HV ]<br>veh/h | %   | [ Total HV ]<br>veh/h | %   |           |             |                  | [ Veh. veh        | Dist ]<br>m |           |                |                     |                  |
| SouthEast: Clarke Ln (SE)    |      |           |                       |     |                       |     |           |             |                  |                   |             |           |                |                     |                  |
| 1                            | L2   | All MCs   | 1                     | 0.0 | 1                     | 0.0 | 0.004     | 4.9         | LOSA             | 0.0               | 0.1         | 0.34      | 0.49           | 0.34                | 32.3             |
| 2                            | T1   | All MCs   | 1                     | 0.0 | 1                     | 0.0 | 0.004     | 5.2         | LOSA             | 0.0               | 0.1         | 0.34      | 0.49           | 0.34                | 32.3             |
| 3                            | R2   | All MCs   | 1                     | 0.0 | 1                     | 0.0 | 0.004     | 6.9         | LOSA             | 0.0               | 0.1         | 0.34      | 0.49           | 0.34                | 32.3             |
| Approach                     |      |           | 3                     | 0.0 | 3                     | 0.0 | 0.004     | 5.7         | LOSA             | 0.0               | 0.1         | 0.34      | 0.49           | 0.34                | 32.3             |
| NorthEast: Oxley St (NE)     |      |           |                       |     |                       |     |           |             |                  |                   |             |           |                |                     |                  |
| 4                            | L2   | All MCs   | 1                     | 0.0 | 1                     | 0.0 | 0.139     | 3.0         | LOSA             | 3.6               | 25.5        | 0.07      | 0.07           | 0.07                | 42.4             |
| 5                            | T1   | All MCs   | 231                   | 0.0 | 231                   | 0.0 | 0.139     | 0.0         | LOSA             | 3.6               | 25.5        | 0.07      | 0.07           | 0.07                | 44.4             |
| 6                            | R2   | All MCs   | 17                    | 0.0 | 17                    | 0.0 | 0.139     | 5.1         | LOSA             | 3.6               | 25.5        | 0.07      | 0.07           | 0.07                | 44.4             |
| Approach                     |      |           | 248                   | 0.0 | 248                   | 0.0 | 0.139     | 0.4         | NA               | 3.6               | 25.5        | 0.07      | 0.07           | 0.07                | 44.4             |
| NorthWest: Clarke Ln (NW)    |      |           |                       |     |                       |     |           |             |                  |                   |             |           |                |                     |                  |
| 7                            | L2   | All MCs   | 20                    | 0.0 | 20                    | 0.0 | 0.028     | 5.2         | LOSA             | 0.1               | 0.8         | 0.33      | 0.52           | 0.33                | 24.9             |
| 8                            | T1   | All MCs   | 1                     | 0.0 | 1                     | 0.0 | 0.028     | 5.2         | LOSA             | 0.1               | 0.8         | 0.33      | 0.52           | 0.33                | 34.0             |
| 9                            | R2   | All MCs   | 5                     | 0.0 | 5                     | 0.0 | 0.028     | 6.9         | LOSA             | 0.1               | 0.8         | 0.33      | 0.52           | 0.33                | 24.9             |
| Approach                     |      |           | 26                    | 0.0 | 26                    | 0.0 | 0.028     | 5.6         | LOSA             | 0.1               | 0.8         | 0.33      | 0.52           | 0.33                | 25.5             |
| SouthWest: Oxley St (SW)     |      |           |                       |     |                       |     |           |             |                  |                   |             |           |                |                     |                  |
| 10                           | L2   | All MCs   | 7                     | 0.0 | 7                     | 0.0 | 0.120     | 3.0         | LOSA             | 0.0               | 0.1         | 0.00      | 0.02           | 0.00                | 48.1             |
| 11                           | T1   | All MCs   | 224                   | 0.0 | 224                   | 0.0 | 0.120     | 0.0         | LOSA             | 0.0               | 0.1         | 0.00      | 0.02           | 0.00                | 48.1             |
| 12                           | R2   | All MCs   | 1                     | 0.0 | 1                     | 0.0 | 0.120     | 3.3         | LOSA             | 0.0               | 0.1         | 0.00      | 0.02           | 0.00                | 42.6             |
| Approach                     |      |           | 233                   | 0.0 | 233                   | 0.0 | 0.120     | 0.1         | NA               | 0.0               | 0.1         | 0.00      | 0.02           | 0.00                | 48.0             |
| All Vehicles                 |      |           | 511                   | 0.0 | 511                   | 0.0 | 0.139     | 0.5         | NA               | 3.6               | 25.5        | 0.05      | 0.07           | 0.05                | 42.3             |

Site Level of Service (LOS) Method: Delay (RTA NSW). Site LOS Method is specified in the Network Data dialog (Override Site Data tab).

Vehicle movement LOS values are based on average delay per movement.

Minor Road Approach LOS values are based on average delay for all vehicle movements.

NA (TWSC): Level of Service is not defined for major road approaches or the intersection as a whole for Two-Way Sign Control (HCM LOS rule).

Two-Way Sign Control Capacity Model: SIDRA Standard.

Delay Model: SIDRA Standard (Control Delay: Geometric Delay is included).

Queue Model: SIDRA queue estimation methods are used for Back of Queue and Queue at Start of Gap.

Gap-Acceptance Capacity Formula: SIDRA Standard (Akçelik M3D).

HV (%) values are calculated for All Movement Classes of All Heavy Vehicle Model Designation.

Arrival Flows used in performance calculations are adjusted to include any Initial Queued Demand and Upstream Capacity Constraint effects.

---

**SIDRA INTERSECTION 9.1 | Copyright © 2000-2022 Akcelik and Associates Pty Ltd | sidrasolutions.com**

Organisation: AECOM AUSTRALIA PTY LTD | Licence: NETWORK / Enterprise Level 1 | Processed: Monday, 17 July 2023 1:41:32 PM

Project: C:\Users\Yeung\AECOM\ANZ-NAC-Sydney Metro-Sydney Metro C&SW Operational Monitoring - General\400\_Technical\432\_Traffic Analysis\SIDRA Modelling\01 Models (Geometry Only)\Block 1\Rev1\\_Review\02 SM C&SW\_CST (Block 1)\_PS.sip9

# MOVEMENT SUMMARY

 Site: CST12 [CST12 Hume St / Clarke Ln (Site Folder: Block 1 Model - 2023 PM Peak)]

Output produced by SIDRA INTERSECTION Version: 9.1.1.200

■ Network: CST-N1 [CST Network 1 (Network Folder: Block 1 Network - 2023 PM Peak)]

NA  
Site Category: (None)  
Stop (Two-Way)

| Vehicle Movement Performance |      |           |                       |     |                       |     |           |             |                  |                   |             |           |                |                     |                  |
|------------------------------|------|-----------|-----------------------|-----|-----------------------|-----|-----------|-------------|------------------|-------------------|-------------|-----------|----------------|---------------------|------------------|
| Mov ID                       | Turn | Mov Class | Demand Flows          |     | Arrival Flows         |     | Deg. Satn | Aver. Delay | Level of Service | 95% Back Of Queue |             | Prop. Que | Eff. Stop Rate | Aver. No. of Cycles | Aver. Speed km/h |
|                              |      |           | [ Total HV ]<br>veh/h | %   | [ Total HV ]<br>veh/h | %   |           |             |                  | [ Veh. veh        | Dist ]<br>m |           |                |                     |                  |
| SouthEast: Clarke Ln (SE)    |      |           |                       |     |                       |     |           |             |                  |                   |             |           |                |                     |                  |
| 3                            | R2   | All MCs   | 22                    | 0.0 | 22                    | 0.0 | 0.012     | 6.9         | LOS A            | 0.0               | 0.0         | 0.00      | 1.00           | 0.00                | 27.8             |
| Approach                     |      |           | 22                    | 0.0 | 22                    | 0.0 | 0.012     | 6.9         | LOS A            | 0.0               | 0.0         | 0.00      | 1.00           | 0.00                | 27.8             |
| NorthEast: Hume St (NE)      |      |           |                       |     |                       |     |           |             |                  |                   |             |           |                |                     |                  |
| 4                            | L2   | All MCs   | 2                     | 0.0 | 2                     | 0.0 | 0.001     | 3.2         | LOS A            | 0.0               | 0.0         | 0.00      | 0.50           | 0.00                | 34.8             |
| Approach                     |      |           | 2                     | 0.0 | 2                     | 0.0 | 0.001     | 3.2         | NA               | 0.0               | 0.0         | 0.00      | 0.50           | 0.00                | 34.8             |
| All Vehicles                 |      |           | 24                    | 0.0 | 24                    | 0.0 | 0.012     | 6.6         | NA               | 0.0               | 0.0         | 0.00      | 0.96           | 0.00                | 28.4             |

Site Level of Service (LOS) Method: Delay (RTA NSW). Site LOS Method is specified in the Network Data dialog (Override Site Data tab).

Vehicle movement LOS values are based on average delay per movement.

Minor Road Approach LOS values are based on average delay for all vehicle movements.

NA (TWSC): Level of Service is not defined for major road approaches or the intersection as a whole for Two-Way Sign Control (HCM LOS rule).

Two-Way Sign Control Capacity Model: SIDRA Standard.

Delay Model: SIDRA Standard (Control Delay: Geometric Delay is included).

Queue Model: SIDRA queue estimation methods are used for Back of Queue and Queue at Start of Gap.

Gap-Acceptance Capacity Formula: SIDRA Standard (Akçelik M3D).

HV (%) values are calculated for All Movement Classes of All Heavy Vehicle Model Designation.

Arrival Flows used in performance calculations are adjusted to include any Initial Queued Demand and Upstream Capacity Constraint effects.

---

**SIDRA INTERSECTION 9.1 | Copyright © 2000-2022 Akcelik and Associates Pty Ltd | sidrasolutions.com**

Organisation: AECOM AUSTRALIA PTY LTD | Licence: NETWORK / Enterprise Level 1 | Processed: Monday, 17 July 2023 1:41:32 PM

Project: C:\Users\Yeung\AECOM\ANZ-NAC-Sydney Metro-Sydney Metro C&SW Operational Monitoring - General\400\_Technical\432\_Traffic Analysis\SIDRA Modelling\01 Models (Geometry Only)\Block 1\Rev1\\_Review\02 SM C&SW\_CST (Block 1)\_PS.sip9

# MOVEMENT SUMMARY

Site: CST13 [CST13 Pacific Hwy / Alexander St (Site Folder: Block 1 Model - 2023 PM Peak)]

Output produced by SIDRA INTERSECTION Version: 9.1.1.200

Network: CST-N1 [CST Network 1 (Network Folder: Block 1 Network - 2023 PM Peak)]

TCS 763

Site Category: (None)

Signals - EQUISAT (Fixed-Time/SCATS) Coordinated Cycle Time = 125 seconds (Network User-Given Cycle Time)

| Vehicle Movement Performance |      |           |                       |     |                       |     |           |             |                  |                   |               |           |                |                     |             |
|------------------------------|------|-----------|-----------------------|-----|-----------------------|-----|-----------|-------------|------------------|-------------------|---------------|-----------|----------------|---------------------|-------------|
| Mov ID                       | Turn | Mov Class | Demand Flows          |     | Arrival Flows         |     | Deg. Satn | Aver. Delay | Level of Service | 95% Back Of Queue |               | Prop. Que | Eff. Stop Rate | Aver. No. of Cycles | Aver. Speed |
|                              |      |           | [ Total HV ]<br>veh/h | %   | [ Total HV ]<br>veh/h | %   |           |             |                  | [ Veh. veh        | [ Dist ]<br>m |           |                |                     |             |
| SouthEast: Pacific Hwy (SE)  |      |           |                       |     |                       |     |           |             |                  |                   |               |           |                |                     |             |
| 2                            | T1   | All MCs   | 984                   | 4.2 | 984                   | 4.2 | *0.539    | 12.3        | LOS A            | 11.8              | 85.6          | 0.74      | 0.65           | 0.74                | 29.8        |
| 3a                           | R1   | All MCs   | 271                   | 2.7 | 271                   | 2.7 | 0.494     | 25.2        | LOS B            | 10.1              | 72.1          | 0.79      | 0.83           | 0.79                | 20.0        |
| Approach                     |      |           | 1255                  | 3.9 | 1255                  | 3.9 | 0.539     | 15.1        | LOS B            | 11.8              | 85.6          | 0.75      | 0.69           | 0.75                | 26.9        |
| North: Alexander St (N)      |      |           |                       |     |                       |     |           |             |                  |                   |               |           |                |                     |             |
| 24a                          | L1   | All MCs   | 232                   | 2.7 | 232                   | 2.7 | *0.399    | 28.6        | LOS C            | 7.6               | 54.2          | 1.00      | 0.78           | 1.00                | 21.1        |
| 26b                          | R3   | All MCs   | 157                   | 0.7 | 157                   | 0.7 | *0.528    | 66.2        | LOS E            | 9.7               | 68.1          | 1.00      | 0.86           | 1.00                | 5.2         |
| Approach                     |      |           | 388                   | 1.9 | 388                   | 1.9 | 0.528     | 43.8        | LOS D            | 9.7               | 68.1          | 1.00      | 0.81           | 1.00                | 13.1        |
| NorthWest: Pacific Hwy (NW)  |      |           |                       |     |                       |     |           |             |                  |                   |               |           |                |                     |             |
| 7b                           | L3   | All MCs   | 19                    | 0.0 | 19                    | 0.0 | 0.076     | 34.1        | LOS C            | 0.8               | 8.6           | 0.64      | 0.60           | 0.64                | 21.6        |
| 8                            | T1   | All MCs   | 954                   | 2.6 | 954                   | 2.6 | 0.514     | 18.7        | LOS B            | 11.4              | 79.9          | 0.72      | 0.62           | 0.72                | 37.4        |
| Approach                     |      |           | 973                   | 2.6 | 973                   | 2.6 | 0.514     | 19.0        | LOS B            | 11.4              | 79.9          | 0.71      | 0.62           | 0.71                | 37.2        |
| All Vehicles                 |      |           | 2616                  | 3.1 | 2616                  | 3.1 | 0.539     | 20.8        | LOS B            | 11.8              | 85.6          | 0.78      | 0.68           | 0.78                | 26.8        |

Site Level of Service (LOS) Method: Delay (RTA NSW). Site LOS Method is specified in the Network Data dialog (Override Site Data tab).

Vehicle movement LOS values are based on average delay per movement.

Intersection and Approach LOS values are based on average delay for all vehicle movements.

Delay Model: SIDRA Standard (Control Delay: Geometric Delay is included).

Queue Model: SIDRA queue estimation methods are used for Back of Queue and Queue at Start of Green.

Gap-Acceptance Capacity Formula: SIDRA Standard (Akçelik M3D).

HV (%) values are calculated for All Movement Classes of All Heavy Vehicle Model Designation.

Arrival Flows used in performance calculations are adjusted to include any Initial Queued Demand and Upstream Capacity Constraint effects.

\* Critical Movement (Signal Timing)



| Pedestrian Movement Performance |          |           |             |                  |                       |        |           |                |             |              |             |
|---------------------------------|----------|-----------|-------------|------------------|-----------------------|--------|-----------|----------------|-------------|--------------|-------------|
| Mov ID                          | Crossing | Dem. Flow | Aver. Delay | Level of Service | AVERAGE BACK OF QUEUE |        | Prop. Que | Eff. Stop Rate | Travel Time | Travel Dist. | Aver. Speed |
|                                 |          | ped/h     | sec         |                  | [ Ped                 | Dist ] |           |                | sec         | m            | m/sec       |
|                                 |          |           |             |                  | ped                   | m      |           |                |             |              |             |
| North: Alexander St (N)         |          |           |             |                  |                       |        |           |                |             |              |             |
| P6                              | Full     | 73        | 20.1        | LOS C            | 0.1                   | 0.1    | 0.79      | 0.79           | 36.8        | 20.0         | 0.54        |
| NorthWest: Pacific Hwy (NW)     |          |           |             |                  |                       |        |           |                |             |              |             |
| P3                              | Full     | 102       | 50.4        | LOS E            | 0.3                   | 0.3    | 0.90      | 0.90           | 67.1        | 20.0         | 0.30        |
| All Pedestrians                 |          | 175       | 37.8        | LOS D            | 0.3                   | 0.3    | 0.86      | 0.86           | 54.5        | 20.0         | 0.37        |

Level of Service (LOS) Method: SIDRA Pedestrian LOS Method (Based on Average Delay)

Pedestrian movement LOS values are based on average delay per pedestrian movement.

Intersection LOS value for Pedestrians is based on average delay for all pedestrian movements.

---

**SIDRA INTERSECTION 9.1 | Copyright © 2000-2022 Kcelik and Associates Pty Ltd | sidrasolutions.com**

Organisation: AECOM AUSTRALIA PTY LTD | Licence: NETWORK / Enterprise Level 1 | Processed: Monday, 17 July 2023 1:41:32 PM

Project: C:\Users\YeungMA\AECOM\ANZ-NAC-Sydney Metro-Sydney Metro C&SW Operational Monitoring - General\400\_Technical\432\_Traffic Analysis\SIDRA Modelling\01 Models (Geometry Only)\Block 1\Rev1\_Review\02 SM C&SW\_CST (Block 1)\_PS.sip9

# MOVEMENT SUMMARY

Site: CST14 [CST14 Falcon St / Alexander St (Site Folder: Block 1 Model - 2023 PM Peak)]

Output produced by SIDRA INTERSECTION Version: 9.1.1.200

Network: CST-N1 [CST Network 1 (Network Folder: Block 1 Network - 2023 PM Peak)]

TCS 764

Site Category: (None)

Signals - EQUISAT (Fixed-Time/SCATS) Coordinated Cycle Time = 125 seconds (Network User-Given Cycle Time)

| Vehicle Movement Performance |      |           |                        |     |                        |     |           |             |                  |                   |               |           |                |                     |                  |
|------------------------------|------|-----------|------------------------|-----|------------------------|-----|-----------|-------------|------------------|-------------------|---------------|-----------|----------------|---------------------|------------------|
| Mov ID                       | Turn | Mov Class | Demand Flows           |     | Arrival Flows          |     | Deg. Satn | Aver. Delay | Level of Service | 95% Back Of Queue |               | Prop. Que | Eff. Stop Rate | Aver. No. of Cycles | Aver. Speed km/h |
|                              |      |           | [ Total HV ]<br>veh/h  | %   | [ Total HV ]<br>veh/h  | %   |           |             |                  | [ Veh. veh        | [ Dist ]<br>m |           |                |                     |                  |
| South: Alexander St (S)      |      |           |                        |     |                        |     |           |             |                  |                   |               |           |                |                     |                  |
| 1                            | L2   | All MCs   | 18                     | 0.0 | 18                     | 0.0 | 0.473     | 42.0        | LOS C            | 7.9               | 57.0          | 0.78      | 0.66           | 0.78                | 8.6              |
| 2                            | T1   | All MCs   | 220                    | 4.8 | 220                    | 4.8 | 0.525     | 35.6        | LOS C            | 7.9               | 57.0          | 0.80      | 0.67           | 0.80                | 13.4             |
| 3                            | R2   | All MCs   | 41                     | 2.6 | 41                     | 2.6 | 0.525     | 52.8        | LOS D            | 5.3               | 38.7          | 0.84      | 0.70           | 0.84                | 23.3             |
| Approach                     |      |           | 279                    | 4.2 | 279                    | 4.2 | 0.525     | 38.5        | LOS C            | 7.9               | 57.0          | 0.80      | 0.67           | 0.80                | 15.2             |
| East: Falcon St (E)          |      |           |                        |     |                        |     |           |             |                  |                   |               |           |                |                     |                  |
| 4                            | L2   | All MCs   | 20                     | 0.0 | 20                     | 0.0 | 0.536     | 24.6        | LOS B            | 16.7              | 118.1         | 0.64      | 0.58           | 0.64                | 33.9             |
| 5                            | T1   | All MCs   | 894                    | 1.2 | 894                    | 1.2 | *0.536    | 18.9        | LOS B            | 16.7              | 118.1         | 0.64      | 0.57           | 0.64                | 34.1             |
| 6                            | R2   | All MCs   | 5 <sup>100.</sup><br>0 |     | 5 <sup>100.</sup><br>0 |     | 0.536     | 25.3        | LOS B            | 16.4              | 117.0         | 0.64      | 0.57           | 0.64                | 34.4             |
| Approach                     |      |           | 919                    | 1.7 | 919                    | 1.7 | 0.536     | 19.0        | LOS B            | 16.7              | 118.1         | 0.64      | 0.57           | 0.64                | 34.1             |
| North: Alexander St (N)      |      |           |                        |     |                        |     |           |             |                  |                   |               |           |                |                     |                  |
| 7                            | L2   | All MCs   | 48                     | 2.2 | 48                     | 2.2 | *0.530    | 57.8        | LOS E            | 10.8              | 77.0          | 0.95      | 0.79           | 0.95                | 21.7             |
| 8                            | T1   | All MCs   | 367                    | 1.7 | 367                    | 1.7 | 0.530     | 47.1        | LOS D            | 12.0              | 84.9          | 0.94      | 0.79           | 0.94                | 6.9              |
| Approach                     |      |           | 416                    | 1.8 | 416                    | 1.8 | 0.530     | 48.4        | LOS D            | 12.0              | 84.9          | 0.94      | 0.79           | 0.94                | 9.3              |
| West: Falcon St (W)          |      |           |                        |     |                        |     |           |             |                  |                   |               |           |                |                     |                  |
| 10                           | L2   | All MCs   | 178                    | 0.6 | 178                    | 0.6 | 0.273     | 5.6         | LOS A            | 0.7               | 5.0           | 0.03      | 0.26           | 0.03                | 40.7             |
| 11                           | T1   | All MCs   | 712                    | 1.8 | 712                    | 1.8 | 0.273     | 0.2         | LOS A            | 0.7               | 5.2           | 0.03      | 0.11           | 0.03                | 58.1             |
| Approach                     |      |           | 889                    | 1.5 | 889                    | 1.5 | 0.273     | 1.3         | LOS A            | 0.7               | 5.2           | 0.03      | 0.14           | 0.03                | 56.1             |
| All Vehicles                 |      |           | 2503                   | 1.9 | 2503                   | 1.9 | 0.536     | 19.8        | LOS B            | 16.7              | 118.1         | 0.49      | 0.47           | 0.49                | 30.7             |

Site Level of Service (LOS) Method: Delay (RTA NSW). Site LOS Method is specified in the Network Data dialog (Override Site Data tab).

Vehicle movement LOS values are based on average delay per movement.

Intersection and Approach LOS values are based on average delay for all vehicle movements.

Delay Model: SIDRA Standard (Control Delay: Geometric Delay is included).

Queue Model: SIDRA queue estimation methods are used for Back of Queue and Queue at Start of Green.

Gap-Acceptance Capacity Formula: SIDRA Standard (Akçelik M3D).

HV (%) values are calculated for All Movement Classes of All Heavy Vehicle Model Designation.

Arrival Flows used in performance calculations are adjusted to include any Initial Queued Demand and Upstream Capacity Constraint effects.

\* Critical Movement (Signal Timing)

| Pedestrian Movement Performance |          |           |             |                  |                       |        |           |                |             |              |             |
|---------------------------------|----------|-----------|-------------|------------------|-----------------------|--------|-----------|----------------|-------------|--------------|-------------|
| Mov ID                          | Crossing | Dem. Flow | Aver. Delay | Level of Service | AVERAGE BACK OF QUEUE |        | Prop. Que | Eff. Stop Rate | Travel Time | Travel Dist. | Aver. Speed |
|                                 |          | ped/h     | sec         |                  | [ Ped                 | Dist ] |           |                | sec         | m            | m/sec       |
|                                 |          |           |             |                  | ped                   | m      |           |                |             |              |             |
| South: Alexander St (S)         |          |           |             |                  |                       |        |           |                |             |              |             |
| P1                              | Full     | 69        | 52.1        | LOS E            | 0.2                   | 0.2    | 0.91      | 0.91           | 68.8        | 20.0         | 0.29        |
| East: Falcon St (E)             |          |           |             |                  |                       |        |           |                |             |              |             |
| P2                              | Full     | 102       | 52.2        | LOS E            | 0.3                   | 0.3    | 0.92      | 0.92           | 68.9        | 20.0         | 0.29        |
| North: Alexander St (N)         |          |           |             |                  |                       |        |           |                |             |              |             |
| P3                              | Full     | 126       | 52.3        | LOS E            | 0.4                   | 0.4    | 0.92      | 0.92           | 68.9        | 20.0         | 0.29        |
| West: Falcon St (W)             |          |           |             |                  |                       |        |           |                |             |              |             |
| P4                              | Full     | 137       | 52.3        | LOS E            | 0.4                   | 0.4    | 0.92      | 0.92           | 68.9        | 20.0         | 0.29        |
| All Pedestrians                 |          | 435       | 52.2        | LOS E            | 0.4                   | 0.4    | 0.92      | 0.92           | 68.9        | 20.0         | 0.29        |

Level of Service (LOS) Method: SIDRA Pedestrian LOS Method (Based on Average Delay)

Pedestrian movement LOS values are based on average delay per pedestrian movement.

Intersection LOS value for Pedestrians is based on average delay for all pedestrian movements.

**SIDRA INTERSECTION 9.1 | Copyright © 2000-2022 Akcelik and Associates Pty Ltd | sidrasolutions.com**

Organisation: AECOM AUSTRALIA PTY LTD | Licence: NETWORK / Enterprise Level 1 | Processed: Monday, 17 July 2023 1:41:32 PM

Project: C:\Users\YeungMA\AECOM\ANZ-NAC-Sydney Metro-Sydney Metro C&SW Operational Monitoring - General\400\_Technical\432\_Traffic Analysis\SIDRA Modelling\01 Models (Geometry Only)\Block 1\Rev1\_Review\02 SM C&SW\_CST (Block 1)\_PS.sip9

# MOVEMENT SUMMARY

Site: CST01 [CST01 Pacific Hwy / Albany St (Site Folder: Block 1 Model - 2023 Weekend Peak)]

Output produced by SIDRA INTERSECTION Version: 9.1.1.200

Network: CST-N1 [CST Network 1 (Network Folder: Block 1 Network - 2023 Weekend Peak)]

TCS 768

Site Category: (None)

Signals - EQUISAT (Fixed-Time/SCATS) Coordinated Cycle Time = 130 seconds (Network User-Given Cycle Time)

| Vehicle Movement Performance |      |           |                       |     |                       |     |           |             |                  |                   |               |           |                |                     |             |
|------------------------------|------|-----------|-----------------------|-----|-----------------------|-----|-----------|-------------|------------------|-------------------|---------------|-----------|----------------|---------------------|-------------|
| Mov ID                       | Turn | Mov Class | Demand Flows          |     | Arrival Flows         |     | Deg. Satn | Aver. Delay | Level of Service | 95% Back Of Queue |               | Prop. Que | Eff. Stop Rate | Aver. No. of Cycles | Aver. Speed |
|                              |      |           | [ Total HV ]<br>veh/h | %   | [ Total HV ]<br>veh/h | %   |           |             |                  | [ Veh. veh        | [ Dist ]<br>m |           |                |                     |             |
| SouthEast: Pacific Hwy (SE)  |      |           |                       |     |                       |     |           |             |                  |                   |               |           |                |                     |             |
| 22                           | T1   | All MCs   | 1125                  | 2.7 | 1125                  | 2.7 | 0.418     | 12.5        | LOS A            | 21.0              | 150.4         | 0.58      | 0.38           | 0.58                | 38.7        |
| 23b                          | R3   | All MCs   | 167                   | 1.3 | 167                   | 1.3 | *0.219    | 36.5        | LOS C            | 7.2               | 50.9          | 0.73      | 0.75           | 0.73                | 14.3        |
| Approach                     |      |           | 1293                  | 2.5 | 1293                  | 2.5 | 0.418     | 15.6        | LOS B            | 21.0              | 150.4         | 0.60      | 0.43           | 0.60                | 34.4        |
| East: Albany St (E)          |      |           |                       |     |                       |     |           |             |                  |                   |               |           |                |                     |             |
| 4b                           | L3   | All MCs   | 26                    | 0.0 | 26                    | 0.0 | 0.903     | 83.8        | LOS F            | 7.0               | 49.0          | 1.00      | 1.04           | 1.30                | 2.1         |
| 6a                           | R1   | All MCs   | 504                   | 0.6 | 504                   | 0.6 | *0.903    | 73.5        | LOS F            | 7.0               | 49.0          | 1.00      | 1.04           | 1.29                | 8.1         |
| Approach                     |      |           | 531                   | 0.6 | 531                   | 0.6 | 0.903     | 74.0        | LOS F            | 7.0               | 49.0          | 1.00      | 1.04           | 1.29                | 7.8         |
| NorthWest: Pacific Hwy (NW)  |      |           |                       |     |                       |     |           |             |                  |                   |               |           |                |                     |             |
| 27a                          | L1   | All MCs   | 351                   | 2.1 | 351                   | 2.1 | 0.717     | 46.0        | LOS D            | 19.4              | 138.4         | 0.93      | 0.84           | 0.93                | 10.6        |
| 28                           | T1   | All MCs   | 711                   | 5.0 | 711                   | 5.0 | *0.888    | 64.9        | LOS E            | 24.9              | 182.0         | 1.00      | 1.04           | 1.21                | 8.0         |
| Approach                     |      |           | 1061                  | 4.1 | 1061                  | 4.1 | 0.888     | 58.6        | LOS E            | 24.9              | 182.0         | 0.98      | 0.98           | 1.12                | 8.7         |
| All Vehicles                 |      |           | 2884                  | 2.7 | 2884                  | 2.7 | 0.903     | 42.2        | LOS C            | 24.9              | 182.0         | 0.81      | 0.74           | 0.92                | 14.9        |

Site Level of Service (LOS) Method: Delay (RTA NSW). Site LOS Method is specified in the Network Data dialog (Override Site Data tab).

Vehicle movement LOS values are based on average delay per movement.

Intersection and Approach LOS values are based on average delay for all vehicle movements.

Delay Model: SIDRA Standard (Control Delay: Geometric Delay is included).

Queue Model: SIDRA queue estimation methods are used for Back of Queue and Queue at Start of Green.

Gap-Acceptance Capacity Formula: SIDRA Standard (Akçelik M3D).

HV (%) values are calculated for All Movement Classes of All Heavy Vehicle Model Designation.

Arrival Flows used in performance calculations are adjusted to include any Initial Queued Demand and Upstream Capacity Constraint effects.

\* Critical Movement (Signal Timing)

| Pedestrian Movement Performance |          |           |             |                  |                       |        |           |                |             |              |             |
|---------------------------------|----------|-----------|-------------|------------------|-----------------------|--------|-----------|----------------|-------------|--------------|-------------|
| Mov ID                          | Crossing | Dem. Flow | Aver. Delay | Level of Service | AVERAGE BACK OF QUEUE |        | Prop. Que | Eff. Stop Rate | Travel Time | Travel Dist. | Aver. Speed |
|                                 |          | ped/h     | sec         |                  | [ Ped                 | Dist ] |           |                | sec         | m            | m/sec       |
|                                 |          |           |             |                  | ped                   | m      |           |                |             |              |             |
| SouthEast: Pacific Hwy (SE)     |          |           |             |                  |                       |        |           |                |             |              |             |
| P5                              | Full     | 160       | 53.0        | LOS E            | 0.5                   | 0.5    | 0.91      | 0.91           | 219.7       | 200.0        | 0.91        |
| East: Albany St (E)             |          |           |             |                  |                       |        |           |                |             |              |             |
| P2                              | Full     | 107       | 52.9        | LOS E            | 0.4                   | 0.4    | 0.90      | 0.90           | 69.6        | 20.0         | 0.29        |
| All Pedestrians                 |          | 267       | 53.0        | LOS E            | 0.5                   | 0.5    | 0.91      | 0.91           | 159.4       | 127.7        | 0.80        |

Level of Service (LOS) Method: SIDRA Pedestrian LOS Method (Based on Average Delay)

Pedestrian movement LOS values are based on average delay per pedestrian movement.

Intersection LOS value for Pedestrians is based on average delay for all pedestrian movements.

---

**SIDRA INTERSECTION 9.1 | Copyright © 2000-2022 Akcelik and Associates Pty Ltd | sidrasolutions.com**

Organisation: AECOM AUSTRALIA PTY LTD | Licence: NETWORK / Enterprise Level 1 | Processed: Monday, 17 July 2023 1:41:44 PM

Project: C:\Users\YeungM\AECOM\ANZ-NAC-Sydney Metro-Sydney Metro C&SW Operational Monitoring - General\400\_Technical\432\_Traffic Analysis\SIDRA Modelling\01 Models (Geometry Only)\Block 1\Rev1\_Review\02 SM C&SW\_CST (Block 1)\_PS.sip9

# MOVEMENT SUMMARY

Site: CST02 [CST02 Pacific Hwy / Oxley St (Site Folder: Block 1 Model - 2023 Weekend Peak)]

Output produced by SIDRA INTERSECTION Version: 9.1.1.200

Network: CST-N1 [CST Network 1 (Network Folder: Block 1 Network - 2023 Weekend Peak)]

TCS 767

Site Category: (None)

Signals - EQUISAT (Fixed-Time/SCATS) Coordinated Cycle Time = 130 seconds (Network User-Given Cycle Time)

| Vehicle Movement Performance |      |           |                       |     |                       |     |           |             |                  |                   |               |           |                |                     |                  |
|------------------------------|------|-----------|-----------------------|-----|-----------------------|-----|-----------|-------------|------------------|-------------------|---------------|-----------|----------------|---------------------|------------------|
| Mov ID                       | Turn | Mov Class | Demand Flows          |     | Arrival Flows         |     | Deg. Satn | Aver. Delay | Level of Service | 95% Back Of Queue |               | Prop. Que | Eff. Stop Rate | Aver. No. of Cycles | Aver. Speed km/h |
|                              |      |           | [ Total HV ]<br>veh/h | %   | [ Total HV ]<br>veh/h | %   |           |             |                  | [ Veh. veh        | [ Dist ]<br>m |           |                |                     |                  |
| SouthEast: Pacific Hwy (SE)  |      |           |                       |     |                       |     |           |             |                  |                   |               |           |                |                     |                  |
| 1                            | L2   | All MCs   | 95                    | 2.2 | 95                    | 2.2 | 0.074     | 13.0        | LOS A            | 1.4               | 10.3          | 0.26      | 0.64           | 0.26                | 36.1             |
| 2                            | T1   | All MCs   | 1107                  | 2.9 | 1107                  | 2.9 | *0.429    | 4.1         | LOS A            | 7.5               | 53.6          | 0.22      | 0.20           | 0.22                | 44.4             |
| Approach                     |      |           | 1202                  | 2.8 | 1202                  | 2.8 | 0.429     | 4.8         | LOS A            | 7.5               | 53.6          | 0.22      | 0.23           | 0.22                | 42.5             |
| NorthEast: Oxley St (NE)     |      |           |                       |     |                       |     |           |             |                  |                   |               |           |                |                     |                  |
| 4                            | L2   | All MCs   | 100                   | 1.1 | 100                   | 1.1 | 0.472     | 62.6        | LOS E            | 6.1               | 43.2          | 0.98      | 0.78           | 0.98                | 2.5              |
| 5                            | T1   | All MCs   | 80                    | 1.3 | 80                    | 1.3 | 0.450     | 62.3        | LOS E            | 5.0               | 35.2          | 0.99      | 0.76           | 0.99                | 13.2             |
| Approach                     |      |           | 180                   | 1.2 | 180                   | 1.2 | 0.472     | 62.5        | LOS E            | 6.1               | 43.2          | 0.98      | 0.77           | 0.98                | 7.9              |
| NorthWest: Pacific Hwy (NW)  |      |           |                       |     |                       |     |           |             |                  |                   |               |           |                |                     |                  |
| 7                            | L2   | All MCs   | 63                    | 0.0 | 63                    | 0.0 | 0.047     | 13.6        | LOS A            | 1.6               | 11.2          | 0.44      | 0.60           | 0.44                | 25.4             |
| 8                            | T1   | All MCs   | 674                   | 5.3 | 674                   | 5.3 | 0.242     | 6.9         | LOS A            | 8.7               | 63.8          | 0.42      | 0.30           | 0.42                | 35.6             |
| Approach                     |      |           | 737                   | 4.9 | 737                   | 4.9 | 0.242     | 7.5         | LOS A            | 8.7               | 63.8          | 0.42      | 0.33           | 0.42                | 34.4             |
| SouthWest: Oxley St (SW)     |      |           |                       |     |                       |     |           |             |                  |                   |               |           |                |                     |                  |
| 10                           | L2   | All MCs   | 185                   | 0.6 | 185                   | 0.6 | *0.810    | 80.7        | LOS F            | 12.4              | 87.1          | 1.00      | 0.92           | 1.18                | 11.0             |
| 11                           | T1   | All MCs   | 111                   | 2.9 | 111                   | 2.9 | 0.399     | 66.9        | LOS E            | 6.5               | 46.4          | 0.95      | 0.76           | 0.95                | 13.4             |
| 12                           | R2   | All MCs   | 88                    | 2.4 | 88                    | 2.4 | 0.609     | 69.8        | LOS E            | 5.7               | 40.8          | 1.00      | 0.80           | 1.03                | 11.0             |
| Approach                     |      |           | 384                   | 1.6 | 384                   | 1.6 | 0.810     | 74.2        | LOS F            | 12.4              | 87.1          | 0.99      | 0.85           | 1.08                | 11.6             |
| All Vehicles                 |      |           | 2503                  | 3.1 | 2503                  | 3.1 | 0.810     | 20.4        | LOS B            | 12.4              | 87.1          | 0.45      | 0.39           | 0.47                | 21.2             |

Site Level of Service (LOS) Method: Delay (RTA NSW). Site LOS Method is specified in the Network Data dialog (Override Site Data tab).

Vehicle movement LOS values are based on average delay per movement.

Intersection and Approach LOS values are based on average delay for all vehicle movements.

Delay Model: SIDRA Standard (Control Delay: Geometric Delay is included).

Queue Model: SIDRA queue estimation methods are used for Back of Queue and Queue at Start of Green.

Gap-Acceptance Capacity Formula: SIDRA Standard (Akçelik M3D).

HV (%) values are calculated for All Movement Classes of All Heavy Vehicle Model Designation.

Arrival Flows used in performance calculations are adjusted to include any Initial Queued Demand and Upstream Capacity Constraint effects.

\* Critical Movement (Signal Timing)

| Pedestrian Movement Performance |          |           |             |                  |                       |        |           |                |             |              |             |
|---------------------------------|----------|-----------|-------------|------------------|-----------------------|--------|-----------|----------------|-------------|--------------|-------------|
| Mov ID                          | Crossing | Dem. Flow | Aver. Delay | Level of Service | AVERAGE BACK OF QUEUE |        | Prop. Que | Eff. Stop Rate | Travel Time | Travel Dist. | Aver. Speed |
|                                 |          | ped/h     | sec         |                  | [ Ped                 | Dist ] |           |                | sec         | m            | m/sec       |
|                                 |          |           |             |                  | ped                   | m      |           |                |             |              |             |
| SouthEast: Pacific Hwy (SE)     |          |           |             |                  |                       |        |           |                |             |              |             |
| P1                              | Full     | 131       | 52.9        | LOS E            | 0.4                   | 0.4    | 0.90      | 0.90           | 69.6        | 20.0         | 0.29        |
| NorthEast: Oxley St (NE)        |          |           |             |                  |                       |        |           |                |             |              |             |
| P2                              | Full     | 52        | 53.7        | LOS E            | 0.2                   | 0.2    | 0.91      | 0.91           | 70.3        | 20.0         | 0.28        |
| SouthWest: Oxley St (SW)        |          |           |             |                  |                       |        |           |                |             |              |             |
| P4                              | Full     | 123       | 53.8        | LOS E            | 0.4                   | 0.4    | 0.91      | 0.91           | 70.5        | 20.0         | 0.28        |
| All Pedestrians                 |          | 305       | 53.4        | LOS E            | 0.4                   | 0.4    | 0.91      | 0.91           | 70.1        | 20.0         | 0.29        |

Level of Service (LOS) Method: SIDRA Pedestrian LOS Method (Based on Average Delay)

Pedestrian movement LOS values are based on average delay per pedestrian movement.

Intersection LOS value for Pedestrians is based on average delay for all pedestrian movements.

**SIDRA INTERSECTION 9.1 | Copyright © 2000-2022 Akcelik and Associates Pty Ltd | sidrasolutions.com**

Organisation: AECOM AUSTRALIA PTY LTD | Licence: NETWORK / Enterprise Level 1 | Processed: Monday, 17 July 2023 1:41:44 PM

Project: C:\Users\YeungM\AECOM\ANZ-NAC-Sydney Metro-Sydney Metro C&SW Operational Monitoring - General\400\_Technical\432\_Traffic Analysis\SIDRA Modelling\01 Models (Geometry Only)\Block 1\Rev1\_Review\02 SM C&SW\_CST (Block 1)\_PS.sip9



# MOVEMENT SUMMARY

Site: CST03 [CST03 Pacific Hwy / Hume St (Site Folder: Block 1 Model - 2023 Weekend Peak)]

Output produced by SIDRA INTERSECTION Version: 9.1.1.200

Network: CST-N1 [CST Network 1 (Network Folder: Block 1 Network - 2023 Weekend Peak)]

TCS 766

Site Category: (None)

Signals - EQUISAT (Fixed-Time/SCATS) Coordinated Cycle Time = 130 seconds (Network User-Given Cycle Time)

| Vehicle Movement Performance |      |           |                       |     |                       |     |           |             |                  |                   |               |           |                |                     |                  |
|------------------------------|------|-----------|-----------------------|-----|-----------------------|-----|-----------|-------------|------------------|-------------------|---------------|-----------|----------------|---------------------|------------------|
| Mov ID                       | Turn | Mov Class | Demand Flows          |     | Arrival Flows         |     | Deg. Satn | Aver. Delay | Level of Service | 95% Back Of Queue |               | Prop. Que | Eff. Stop Rate | Aver. No. of Cycles | Aver. Speed km/h |
|                              |      |           | [ Total HV ]<br>veh/h | %   | [ Total HV ]<br>veh/h | %   |           |             |                  | [ Veh. veh        | [ Dist ]<br>m |           |                |                     |                  |
| SouthEast: Pacific Hwy (SE)  |      |           |                       |     |                       |     |           |             |                  |                   |               |           |                |                     |                  |
| 1                            | L2   | All MCs   | 35                    | 3.0 | 35                    | 3.0 | 0.090     | 7.4         | LOS A            | 0.9               | 6.5           | 0.12      | 0.24           | 0.12                | 34.4             |
| 2                            | T1   | All MCs   | 1124                  | 3.0 | 1124                  | 3.0 | *0.339    | 2.3         | LOS A            | 7.5               | 53.6          | 0.19      | 0.19           | 0.19                | 50.6             |
| Approach                     |      |           | 1159                  | 3.0 | 1159                  | 3.0 | 0.339     | 2.5         | LOS A            | 7.5               | 53.6          | 0.19      | 0.19           | 0.19                | 49.7             |
| NorthWest: Pacific Hwy (NW)  |      |           |                       |     |                       |     |           |             |                  |                   |               |           |                |                     |                  |
| 8                            | T1   | All MCs   | 865                   | 4.7 | 865                   | 4.7 | 0.294     | 0.5         | LOS A            | 1.2               | 8.8           | 0.05      | 0.04           | 0.05                | 56.6             |
| 9                            | R2   | All MCs   | 100                   | 0   | 100                   | 0   | 0.294     | 7.2         | LOS A            | 1.2               | 8.5           | 0.05      | 0.04           | 0.05                | 26.1             |
| Approach                     |      |           | 866                   | 4.9 | 866                   | 4.9 | 0.294     | 0.5         | LOS A            | 1.2               | 8.8           | 0.05      | 0.04           | 0.05                | 56.5             |
| SouthWest: Hume St (SW)      |      |           |                       |     |                       |     |           |             |                  |                   |               |           |                |                     |                  |
| 10                           | L2   | All MCs   | 78                    | 0.0 | 78                    | 0.0 | *0.419    | 65.9        | LOS E            | 4.8               | 33.6          | 0.98      | 0.77           | 0.98                | 4.3              |
| 12                           | R2   | All MCs   | 29                    | 0.0 | 29                    | 0.0 | 0.159     | 63.5        | LOS E            | 1.8               | 12.3          | 0.95      | 0.72           | 0.95                | 4.6              |
| Approach                     |      |           | 107                   | 0.0 | 107                   | 0.0 | 0.419     | 65.3        | LOS E            | 4.8               | 33.6          | 0.97      | 0.75           | 0.97                | 4.4              |
| All Vehicles                 |      |           | 2133                  | 3.6 | 2133                  | 3.6 | 0.419     | 4.8         | LOS A            | 7.5               | 53.6          | 0.17      | 0.16           | 0.17                | 40.6             |

Site Level of Service (LOS) Method: Delay (RTA NSW). Site LOS Method is specified in the Network Data dialog (Override Site Data tab).

Vehicle movement LOS values are based on average delay per movement.

Intersection and Approach LOS values are based on average delay for all vehicle movements.

Delay Model: SIDRA Standard (Control Delay: Geometric Delay is included).

Queue Model: SIDRA queue estimation methods are used for Back of Queue and Queue at Start of Green.

Gap-Acceptance Capacity Formula: SIDRA Standard (Akçelik M3D).

HV (%) values are calculated for All Movement Classes of All Heavy Vehicle Model Designation.

Arrival Flows used in performance calculations are adjusted to include any Initial Queued Demand and Upstream Capacity Constraint effects.

\* Critical Movement (Signal Timing)

| Pedestrian Movement Performance |          |           |             |                  |                       |        |           |                |             |              |             |
|---------------------------------|----------|-----------|-------------|------------------|-----------------------|--------|-----------|----------------|-------------|--------------|-------------|
| Mov ID                          | Crossing | Dem. Flow | Aver. Delay | Level of Service | AVERAGE BACK OF QUEUE |        | Prop. Que | Eff. Stop Rate | Travel Time | Travel Dist. | Aver. Speed |
|                                 |          | ped/h     | sec         |                  | [ Ped                 | Dist ] |           |                | sec         | m            | m/sec       |
|                                 |          |           |             |                  | ped                   | m      |           |                |             |              |             |
| SouthEast: Pacific Hwy (SE)     |          |           |             |                  |                       |        |           |                |             |              |             |
| P1                              | Full     | 12        | 52.7        | LOS E            | 0.0                   | 0.0    | 0.90      | 0.90           | 69.3        | 20.0         | 0.29        |
| NorthWest: Pacific Hwy (NW)     |          |           |             |                  |                       |        |           |                |             |              |             |
| P3                              | Full     | 12        | 52.7        | LOS E            | 0.0                   | 0.0    | 0.90      | 0.90           | 69.3        | 20.0         | 0.29        |
| SouthWest: Hume St (SW)         |          |           |             |                  |                       |        |           |                |             |              |             |
| P4                              | Full     | 67        | 55.5        | LOS E            | 0.2                   | 0.2    | 0.93      | 0.93           | 72.2        | 20.0         | 0.28        |
| All Pedestrians                 |          | 91        | 54.8        | LOS E            | 0.2                   | 0.2    | 0.92      | 0.92           | 71.5        | 20.0         | 0.28        |

Level of Service (LOS) Method: SIDRA Pedestrian LOS Method (Based on Average Delay)

Pedestrian movement LOS values are based on average delay per pedestrian movement.

Intersection LOS value for Pedestrians is based on average delay for all pedestrian movements.

**SIDRA INTERSECTION 9.1 | Copyright © 2000-2022 Akcelik and Associates Pty Ltd | sidrasolutions.com**

Organisation: AECOM AUSTRALIA PTY LTD | Licence: NETWORK / Enterprise Level 1 | Processed: Monday, 17 July 2023 1:41:44 PM

Project: C:\Users\YeungM\AECOM\ANZ-NAC-Sydney Metro-Sydney Metro C&SW Operational Monitoring - General\400\_Technical\432\_Traffic Analysis\SIDRA Modelling\01 Models (Geometry Only)\Block 1\Rev1\_Review\02 SM C&SW\_CST (Block 1)\_PS.sip9

# MOVEMENT SUMMARY

Site: CST04 [CST04 Pacific Hwy / Falcon St / Shirley Rd (Site Folder: Block 1 Model - 2023 Weekend Peak)]

Output produced by SIDRA INTERSECTION Version: 9.1.1.200

Network: CST-N1 [CST Network 1 (Network Folder: Block 1 Network - 2023 Weekend Peak)]

TCS 765

Site Category: (None)

Signals - EQUISAT (Fixed-Time/SCATS) Coordinated Cycle Time = 130 seconds (Network User-Given Cycle Time)

| Vehicle Movement Performance |      |           |                       |      |                       |      |           |             |                  |                   |               |           |                |                     |             |
|------------------------------|------|-----------|-----------------------|------|-----------------------|------|-----------|-------------|------------------|-------------------|---------------|-----------|----------------|---------------------|-------------|
| Mov ID                       | Turn | Mov Class | Demand Flows          |      | Arrival Flows         |      | Deg. Satn | Aver. Delay | Level of Service | 95% Back Of Queue |               | Prop. Que | Eff. Stop Rate | Aver. No. of Cycles | Aver. Speed |
|                              |      |           | [ Total HV ]<br>veh/h | %    | [ Total HV ]<br>veh/h | %    |           |             |                  | [ Veh. veh        | [ Dist ]<br>m |           |                |                     |             |
| SouthEast: Pacific Hwy (SE)  |      |           |                       |      |                       |      |           |             |                  |                   |               |           |                |                     |             |
| 1                            | L2   | All MCs   | 261                   | 1.2  | 261                   | 1.2  | 0.268     | 19.4        | LOS B            | 7.4               | 52.0          | 0.48      | 0.71           | 0.48                | 27.8        |
| 2                            | T1   | All MCs   | 675                   | 2.2  | 675                   | 2.2  | 0.605     | 35.7        | LOS C            | 17.4              | 124.2         | 0.85      | 0.73           | 0.85                | 11.2        |
| Approach                     |      |           | 936                   | 1.9  | 936                   | 1.9  | 0.605     | 31.1        | LOS C            | 17.4              | 124.2         | 0.74      | 0.72           | 0.74                | 15.9        |
| East: Falcon St (E)          |      |           |                       |      |                       |      |           |             |                  |                   |               |           |                |                     |             |
| 21b                          | L3   | All MCs   | 14                    | 0.0  | 14                    | 0.0  | 0.897     | 18.6        | LOS B            | 18.5              | 130.6         | 0.95      | 0.94           | 1.08                | 7.1         |
| 21a                          | L1   | All MCs   | 384                   | 1.1  | 384                   | 1.1  | *0.897    | 45.7        | LOS D            | 18.5              | 130.6         | 0.95      | 0.94           | 1.08                | 16.5        |
| 23a                          | R1   | All MCs   | 437                   | 4.1  | 437                   | 4.1  | 0.756     | 33.2        | LOS C            | 18.0              | 130.6         | 0.84      | 0.82           | 0.85                | 8.9         |
| Approach                     |      |           | 835                   | 2.6  | 835                   | 2.6  | 0.897     | 38.7        | LOS C            | 18.5              | 130.6         | 0.90      | 0.88           | 0.96                | 13.4        |
| North: Willoughby Rd (N)     |      |           |                       |      |                       |      |           |             |                  |                   |               |           |                |                     |             |
| 7                            | L2   | All MCs   | 22                    | 14.3 | 22                    | 14.3 | 0.017     | 3.7         | LOS A            | 0.1               | 0.7           | 0.07      | 0.47           | 0.07                | 37.1        |
| Approach                     |      |           | 22                    | 14.3 | 22                    | 14.3 | 0.017     | 3.7         | LOS A            | 0.1               | 0.7           | 0.07      | 0.47           | 0.07                | 37.1        |
| NorthWest: Pacific Hwy (NW)  |      |           |                       |      |                       |      |           |             |                  |                   |               |           |                |                     |             |
| 7a                           | L1   | All MCs   | 349                   | 4.8  | 349                   | 4.8  | *0.444    | 18.1        | LOS B            | 8.9               | 65.2          | 0.71      | 0.77           | 0.71                | 24.4        |
| 8                            | T1   | All MCs   | 536                   | 4.1  | 536                   | 4.1  | 0.544     | 14.1        | LOS A            | 8.0               | 57.8          | 0.44      | 0.38           | 0.44                | 28.4        |
| Approach                     |      |           | 885                   | 4.4  | 885                   | 4.4  | 0.544     | 15.7        | LOS B            | 8.9               | 65.2          | 0.55      | 0.53           | 0.55                | 26.7        |
| SouthWest: Shirley Rd (SW)   |      |           |                       |      |                       |      |           |             |                  |                   |               |           |                |                     |             |
| 10                           | L2   | All MCs   | 64                    | 3.3  | 64                    | 3.3  | 0.966     | 98.2        | LOS F            | 30.5              | 215.3         | 1.00      | 1.18           | 1.40                | 8.1         |
| 12a                          | R1   | All MCs   | 612                   | 0.7  | 612                   | 0.7  | *0.966    | 84.7        | LOS F            | 35.3              | 248.8         | 1.00      | 1.17           | 1.39                | 8.1         |
| 12                           | R2   | All MCs   | 143                   | 0.7  | 143                   | 0.7  | 0.966     | 86.5        | LOS F            | 35.3              | 248.8         | 1.00      | 1.17           | 1.37                | 8.2         |
| Approach                     |      |           | 819                   | 0.9  | 819                   | 0.9  | 0.966     | 86.0        | LOS F            | 35.3              | 248.8         | 1.00      | 1.17           | 1.38                | 8.2         |
| All Vehicles                 |      |           | 3497                  | 2.6  | 3497                  | 2.6  | 0.966     | 41.7        | LOS C            | 35.3              | 248.8         | 0.79      | 0.82           | 0.89                | 13.5        |

Site Level of Service (LOS) Method: Delay (RTA NSW). Site LOS Method is specified in the Network Data dialog (Override Site Data tab).

Vehicle movement LOS values are based on average delay per movement.

Intersection and Approach LOS values are based on average delay for all vehicle movements.

Delay Model: SIDRA Standard (Control Delay: Geometric Delay is included).

Queue Model: SIDRA queue estimation methods are used for Back of Queue and Queue at Start of Green.

Gap-Acceptance Capacity Formula: SIDRA Standard (Akçelik M3D).

HV (%) values are calculated for All Movement Classes of All Heavy Vehicle Model Designation.

Arrival Flows used in performance calculations are adjusted to include any Initial Queued Demand and Upstream Capacity Constraint effects.

\* Critical Movement (Signal Timing)

| Pedestrian Movement Performance |          |           |             |                  |                       |        |           |                |             |              |             |
|---------------------------------|----------|-----------|-------------|------------------|-----------------------|--------|-----------|----------------|-------------|--------------|-------------|
| Mov ID                          | Crossing | Dem. Flow | Aver. Delay | Level of Service | AVERAGE BACK OF QUEUE |        | Prop. Que | Eff. Stop Rate | Travel Time | Travel Dist. | Aver. Speed |
|                                 |          | ped/h     | sec         |                  | [ Ped                 | Dist ] |           |                | sec         | m            | m/sec       |
|                                 |          |           |             |                  | ped                   | m      |           |                |             |              |             |
| SouthEast: Pacific Hwy (SE)     |          |           |             |                  |                       |        |           |                |             |              |             |
| P1                              | Full     | 109       | 52.0        | LOS E            | 0.4                   | 0.4    | 0.90      | 0.90           | 68.7        | 20.0         | 0.29        |
| East: Falcon St (E)             |          |           |             |                  |                       |        |           |                |             |              |             |
| P5                              | Full     | 94        | 55.6        | LOS E            | 0.3                   | 0.3    | 0.93      | 0.93           | 72.3        | 20.0         | 0.28        |
| NorthWest: Pacific Hwy (NW)     |          |           |             |                  |                       |        |           |                |             |              |             |
| P3                              | Full     | 189       | 52.2        | LOS E            | 0.6                   | 0.6    | 0.90      | 0.90           | 68.8        | 20.0         | 0.29        |
| SouthWest: Shirley Rd (SW)      |          |           |             |                  |                       |        |           |                |             |              |             |
| P4                              | Full     | 72        | 55.6        | LOS E            | 0.2                   | 0.2    | 0.93      | 0.93           | 72.2        | 20.0         | 0.28        |
| All Pedestrians                 |          | 464       | 53.3        | LOS E            | 0.6                   | 0.6    | 0.91      | 0.91           | 70.0        | 20.0         | 0.29        |

Level of Service (LOS) Method: SIDRA Pedestrian LOS Method (Based on Average Delay)

Pedestrian movement LOS values are based on average delay per pedestrian movement.

Intersection LOS value for Pedestrians is based on average delay for all pedestrian movements.

**SIDRA INTERSECTION 9.1 | Copyright © 2000-2022 Akcelik and Associates Pty Ltd | sidrasolutions.com**

Organisation: AECOM AUSTRALIA PTY LTD | Licence: NETWORK / Enterprise Level 1 | Processed: Monday, 17 July 2023 1:41:44 PM

Project: C:\Users\YeungMA\AECOM\ANZ-NAC-Sydney Metro-Sydney Metro C&SW Operational Monitoring - General\400\_Technical\432\_Traffic Analysis\SIDRA Modelling\01 Models (Geometry Only)\Block 1\Rev1\_Review\02 SM C&SW\_CST (Block 1)\_PS.sip9

# MOVEMENT SUMMARY

Site: CST05 [CST05 Clarke St / Oxley St (Site Folder: Block 1 Model - 2023 Weekend Peak)]

Output produced by SIDRA INTERSECTION Version: 9.1.1.200

Network: CST-N1 [CST Network 1 (Network Folder: Block 1 Network - 2023 Weekend Peak)]

NA  
 Site Category: (None)  
 Give-Way (Two-Way)

| Vehicle Movement Performance |      |           |                       |     |                       |     |           |             |                  |                   |             |           |                |                     |                  |
|------------------------------|------|-----------|-----------------------|-----|-----------------------|-----|-----------|-------------|------------------|-------------------|-------------|-----------|----------------|---------------------|------------------|
| Mov ID                       | Turn | Mov Class | Demand Flows          |     | Arrival Flows         |     | Deg. Satn | Aver. Delay | Level of Service | 95% Back Of Queue |             | Prop. Que | Eff. Stop Rate | Aver. No. of Cycles | Aver. Speed km/h |
|                              |      |           | [ Total HV ]<br>veh/h | %   | [ Total HV ]<br>veh/h | %   |           |             |                  | [ Veh. veh        | Dist ]<br>m |           |                |                     |                  |
| SouthEast: Clarke St (SE)    |      |           |                       |     |                       |     |           |             |                  |                   |             |           |                |                     |                  |
| 1                            | L2   | All MCs   | 42                    | 0.0 | 42                    | 0.0 | 0.095     | 5.0         | LOS A            | 0.3               | 2.4         | 0.31      | 0.55           | 0.31                | 32.6             |
| 3a                           | R1   | All MCs   | 60                    | 0.0 | 60                    | 0.0 | 0.095     | 5.7         | LOS A            | 0.3               | 2.4         | 0.31      | 0.55           | 0.31                | 32.6             |
| Approach                     |      |           | 102                   | 0.0 | 102                   | 0.0 | 0.095     | 5.4         | LOS A            | 0.3               | 2.4         | 0.31      | 0.55           | 0.31                | 32.6             |
| North: Oxley St (N)          |      |           |                       |     |                       |     |           |             |                  |                   |             |           |                |                     |                  |
| 24a                          | L1   | All MCs   | 146                   | 0.7 | 146                   | 0.7 | 0.147     | 4.4         | LOS A            | 0.0               | 0.0         | 0.00      | 0.53           | 0.00                | 29.5             |
| 26a                          | R1   | All MCs   | 132                   | 0.8 | 132                   | 0.8 | 0.147     | 4.1         | LOS A            | 0.0               | 0.0         | 0.00      | 0.53           | 0.00                | 29.5             |
| Approach                     |      |           | 278                   | 0.8 | 278                   | 0.8 | 0.147     | 4.3         | NA               | 0.0               | 0.0         | 0.00      | 0.53           | 0.00                | 29.5             |
| SouthWest: Oxley St (SW)     |      |           |                       |     |                       |     |           |             |                  |                   |             |           |                |                     |                  |
| 10a                          | L1   | All MCs   | 128                   | 1.6 | 128                   | 1.6 | 0.113     | 2.8         | LOS A            | 0.4               | 3.0         | 0.26      | 0.54           | 0.26                | 22.6             |
| 12                           | R2   | All MCs   | 61                    | 1.7 | 61                    | 1.7 | 0.113     | 5.0         | LOS A            | 0.4               | 3.0         | 0.26      | 0.54           | 0.26                | 22.6             |
| Approach                     |      |           | 189                   | 1.7 | 189                   | 1.7 | 0.113     | 3.5         | NA               | 0.4               | 3.0         | 0.26      | 0.54           | 0.26                | 22.6             |
| All Vehicles                 |      |           | 569                   | 0.9 | 569                   | 0.9 | 0.147     | 4.2         | NA               | 0.4               | 3.0         | 0.14      | 0.54           | 0.14                | 28.9             |

Site Level of Service (LOS) Method: Delay (RTA NSW). Site LOS Method is specified in the Network Data dialog (Override Site Data tab).

Vehicle movement LOS values are based on average delay per movement.

Minor Road Approach LOS values are based on average delay for all vehicle movements.

NA (TWSC): Level of Service is not defined for major road approaches or the intersection as a whole for Two-Way Sign Control (HCM LOS rule).

Two-Way Sign Control Capacity Model: SIDRA Standard.

Delay Model: SIDRA Standard (Control Delay: Geometric Delay is included).

Queue Model: SIDRA queue estimation methods are used for Back of Queue and Queue at Start of Gap.

Gap-Acceptance Capacity Formula: SIDRA Standard (Akçelik M3D).

HV (%) values are calculated for All Movement Classes of All Heavy Vehicle Model Designation.

Arrival Flows used in performance calculations are adjusted to include any Initial Queued Demand and Upstream Capacity Constraint effects.

---

**SIDRA INTERSECTION 9.1 | Copyright © 2000-2022 Akcelik and Associates Pty Ltd | sidrasolutions.com**

Organisation: AECOM AUSTRALIA PTY LTD | Licence: NETWORK / Enterprise Level 1 | Processed: Monday, 17 July 2023 1:41:44 PM

Project: C:\Users\Yeung\AECOM\ANZ-NAC-Sydney Metro-Sydney Metro C&SW Operational Monitoring - General\400\_Technical\432\_Traffic Analysis\SIDRA Modelling\01 Models (Geometry Only)\Block 1\Rev1\\_Review\02 SM C&SW\_CST (Block 1)\_PS.sip9

# MOVEMENT SUMMARY

Site: CST06 [CST06 Clarke St / Hume St (Site Folder: Block 1 Model - 2023 Weekend Peak)]

Output produced by SIDRA INTERSECTION Version: 9.1.1.200

Network: CST-N1 [CST Network 1 (Network Folder: Block 1 Network - 2023 Weekend Peak)]

NA  
 Site Category: (None)  
 Give-Way (Two-Way)

| Vehicle Movement Performance |      |           |                       |     |                       |     |           |             |                  |                   |             |           |                |                     |                  |
|------------------------------|------|-----------|-----------------------|-----|-----------------------|-----|-----------|-------------|------------------|-------------------|-------------|-----------|----------------|---------------------|------------------|
| Mov ID                       | Turn | Mov Class | Demand Flows          |     | Arrival Flows         |     | Deg. Satn | Aver. Delay | Level of Service | 95% Back Of Queue |             | Prop. Que | Eff. Stop Rate | Aver. No. of Cycles | Aver. Speed km/h |
|                              |      |           | [ Total HV ]<br>veh/h | %   | [ Total HV ]<br>veh/h | %   |           |             |                  | [ Veh. veh        | Dist ]<br>m |           |                |                     |                  |
| SouthEast: Clarke St (SE)    |      |           |                       |     |                       |     |           |             |                  |                   |             |           |                |                     |                  |
| 1                            | L2   | All MCs   | 1                     | 0.0 | 1                     | 0.0 | 0.068     | 4.6         | LOS A            | 0.0               | 0.0         | 0.00      | 0.00           | 0.00                | 49.7             |
| 2                            | T1   | All MCs   | 131                   | 0.0 | 131                   | 0.0 | 0.068     | 0.0         | LOS A            | 0.0               | 0.0         | 0.00      | 0.00           | 0.00                | 49.7             |
| Approach                     |      |           | 132                   | 0.0 | 132                   | 0.0 | 0.068     | 0.0         | NA               | 0.0               | 0.0         | 0.00      | 0.00           | 0.00                | 49.7             |
| NorthWest: Clarke St (NW)    |      |           |                       |     |                       |     |           |             |                  |                   |             |           |                |                     |                  |
| 8                            | T1   | All MCs   | 198                   | 0.5 | 198                   | 0.5 | 0.103     | 0.0         | LOS A            | 0.0               | 0.1         | 0.00      | 0.00           | 0.00                | 49.9             |
| 9                            | R2   | All MCs   | 1                     | 0.0 | 1                     | 0.0 | 0.103     | 4.6         | LOS A            | 0.0               | 0.1         | 0.00      | 0.00           | 0.00                | 49.8             |
| Approach                     |      |           | 199                   | 0.5 | 199                   | 0.5 | 0.103     | 0.0         | NA               | 0.0               | 0.1         | 0.00      | 0.00           | 0.00                | 49.9             |
| SouthWest: Hume St (SW)      |      |           |                       |     |                       |     |           |             |                  |                   |             |           |                |                     |                  |
| 10                           | L2   | All MCs   | 2                     | 0.0 | 2                     | 0.0 | 0.005     | 3.5         | LOS A            | 0.0               | 0.1         | 0.25      | 0.48           | 0.25                | 23.7             |
| 12                           | R2   | All MCs   | 1                     | 0.0 | 1                     | 0.0 | 0.005     | 4.3         | LOS A            | 0.0               | 0.1         | 0.25      | 0.48           | 0.25                | 31.8             |
| Approach                     |      |           | 3                     | 0.0 | 3                     | 0.0 | 0.005     | 3.8         | LOS A            | 0.0               | 0.1         | 0.25      | 0.48           | 0.25                | 28.0             |
| All Vehicles                 |      |           | 334                   | 0.3 | 334                   | 0.3 | 0.103     | 0.1         | NA               | 0.0               | 0.1         | 0.00      | 0.01           | 0.00                | 49.7             |

Site Level of Service (LOS) Method: Delay (RTA NSW). Site LOS Method is specified in the Network Data dialog (Override Site Data tab).

Vehicle movement LOS values are based on average delay per movement.

Minor Road Approach LOS values are based on average delay for all vehicle movements.

NA (TWSC): Level of Service is not defined for major road approaches or the intersection as a whole for Two-Way Sign Control (HCM LOS rule).

Two-Way Sign Control Capacity Model: SIDRA Standard.

Delay Model: SIDRA Standard (Control Delay: Geometric Delay is included).

Queue Model: SIDRA queue estimation methods are used for Back of Queue and Queue at Start of Gap.

Gap-Acceptance Capacity Formula: SIDRA Standard (Akçelik M3D).

HV (%) values are calculated for All Movement Classes of All Heavy Vehicle Model Designation.

Arrival Flows used in performance calculations are adjusted to include any Initial Queued Demand and Upstream Capacity Constraint effects.



---

**SIDRA INTERSECTION 9.1 | Copyright © 2000-2022 Akcelik and Associates Pty Ltd | sidrasolutions.com**

Organisation: AECOM AUSTRALIA PTY LTD | Licence: NETWORK / Enterprise Level 1 | Processed: Monday, 17 July 2023 1:41:44 PM

Project: C:\Users\Yeung\AECOM\ANZ-NAC-Sydney Metro-Sydney Metro C&SW Operational Monitoring - General\400\_Technical\432\_Traffic Analysis\SIDRA Modelling\01 Models (Geometry Only)\Block 1\Rev1\\_Review\02 SM C&SW\_CST (Block 1)\_PS.sip9

# MOVEMENT SUMMARY

Site: CST07 [CST07 Clarke St / Willoughby Rd (Site Folder: Block 1 Model - 2023 Weekend Peak)]

Output produced by SIDRA INTERSECTION Version: 9.1.1.200

NA

Site Category: (None)

Give-Way (Two-Way)

| Vehicle Movement Performance |      |           |              |     |               |     |           |             |                  |                   |          |           |                |                     |             |
|------------------------------|------|-----------|--------------|-----|---------------|-----|-----------|-------------|------------------|-------------------|----------|-----------|----------------|---------------------|-------------|
| Mov ID                       | Turn | Mov Class | Demand Flows |     | Arrival Flows |     | Deg. Satn | Aver. Delay | Level of Service | 95% Back Of Queue |          | Prop. Que | Eff. Stop Rate | Aver. No. of Cycles | Aver. Speed |
|                              |      |           | [ Total HV ] | %   | [ Total HV ]  | %   | v/c       | sec         |                  | [ Veh. ]          | [ Dist ] |           |                |                     | km/h        |
|                              |      |           | veh/h        |     | veh/h         |     |           |             |                  | veh               | m        |           |                |                     |             |
| South: Willoughby Rd (S)     |      |           |              |     |               |     |           |             |                  |                   |          |           |                |                     |             |
| 1                            | L2   | All MCs   | 94           | 0.0 | 94            | 0.0 | 0.222     | 4.0         | LOS A            | 1.1               | 7.9      | 0.38      | 0.36           | 0.38                | 31.2        |
| 2                            | T1   | All MCs   | 125          | 5.9 | 125           | 5.9 | 0.222     | 2.2         | LOS A            | 1.1               | 7.9      | 0.38      | 0.36           | 0.38                | 35.9        |
| Approach                     |      |           | 219          | 3.4 | 219           | 3.4 | 0.222     | 3.0         | NA               | 1.1               | 7.9      | 0.38      | 0.36           | 0.38                | 34.4        |
| North: Willoughby Rd (N)     |      |           |              |     |               |     |           |             |                  |                   |          |           |                |                     |             |
| 8                            | T1   | All MCs   | 182          | 4.6 | 182           | 4.6 | 0.264     | 2.2         | LOS A            | 1.2               | 8.5      | 0.42      | 0.38           | 0.42                | 35.7        |
| 9                            | R2   | All MCs   | 44           | 2.4 | 44            | 2.4 | 0.264     | 7.4         | LOS A            | 1.2               | 8.5      | 0.42      | 0.38           | 0.42                | 34.8        |
| Approach                     |      |           | 226          | 4.2 | 226           | 4.2 | 0.264     | 3.2         | NA               | 1.2               | 8.5      | 0.42      | 0.38           | 0.42                | 35.5        |
| West: Clarke St (W)          |      |           |              |     |               |     |           |             |                  |                   |          |           |                |                     |             |
| 10                           | L2   | All MCs   | 84           | 0.0 | 84            | 0.0 | 0.190     | 5.7         | LOS A            | 0.7               | 5.0      | 0.50      | 0.68           | 0.50                | 32.7        |
| 12                           | R2   | All MCs   | 82           | 1.3 | 82            | 1.3 | 0.190     | 6.2         | LOS A            | 0.7               | 5.0      | 0.50      | 0.68           | 0.50                | 26.7        |
| Approach                     |      |           | 166          | 0.6 | 166           | 0.6 | 0.190     | 5.9         | LOS A            | 0.7               | 5.0      | 0.50      | 0.68           | 0.50                | 30.6        |
| All Vehicles                 |      |           | 612          | 2.9 | 612           | 2.9 | 0.264     | 3.9         | NA               | 1.2               | 8.5      | 0.43      | 0.45           | 0.43                | 33.7        |

Site Level of Service (LOS) Method: Delay (RTA NSW). Site LOS Method is specified in the Parameter Settings dialog (Options tab).

Vehicle movement LOS values are based on average delay per movement.

Minor Road Approach LOS values are based on average delay for all vehicle movements.

NA (TWSC): Level of Service is not defined for major road approaches or the intersection as a whole for Two-Way Sign Control (HCM LOS rule).

Two-Way Sign Control Capacity Model: SIDRA Standard.

Delay Model: SIDRA Standard (Control Delay: Geometric Delay is included).

Queue Model: SIDRA queue estimation methods are used for Back of Queue and Queue at Start of Gap.

Gap-Acceptance Capacity Formula: SIDRA Standard (Akçelik M3D).

HV (%) values are calculated for All Movement Classes of All Heavy Vehicle Model Designation.

Arrival Flows used in performance calculations are adjusted to include any Initial Queued Demand and Upstream Capacity Constraint effects.

---

**SIDRA INTERSECTION 9.1 | Copyright © 2000-2022 Akcelik and Associates Pty Ltd | sidrasolutions.com**

Organisation: AECOM AUSTRALIA PTY LTD | Licence: NETWORK / Enterprise Level 1 | Processed: Thursday, 13 July 2023 6:24:46 PM

Project: C:\Users\Yeung\AECOM\ANZ-NAC-Sydney Metro-Sydney Metro C&SW Operational Monitoring - General\400\_Technical\432\_Traffic Analysis\SIDRA Modelling\01 Models (Geometry Only)\Block 1\Rev1\\_Review\02 SM C&SW\_CST (Block 1)\_PS.sip9

# MOVEMENT SUMMARY

**Site: CST08 [CST08 Albany St / Willoughby Rd (Site Folder: Block 1 Model - 2023 Weekend Peak)]**

**Output produced by SIDRA INTERSECTION Version: 9.1.1.200**

TCS 516

Site Category: (None)

Signals - EQUISAT (Fixed-Time/SCATS) Isolated Cycle Time = 80 seconds (Site User-Given Phase Times)

| Vehicle Movement Performance |      |           |              |     |               |     |           |             |                  |                   |          |           |                |                     |             |
|------------------------------|------|-----------|--------------|-----|---------------|-----|-----------|-------------|------------------|-------------------|----------|-----------|----------------|---------------------|-------------|
| Mov ID                       | Turn | Mov Class | Demand Flows |     | Arrival Flows |     | Deg. Satn | Aver. Delay | Level of Service | 95% Back Of Queue |          | Prop. Que | Eff. Stop Rate | Aver. No. of Cycles | Aver. Speed |
|                              |      |           | [ Total HV ] | %   | [ Total HV ]  | %   | v/c       | sec         |                  | [ Veh. ]          | [ Dist ] |           |                |                     | km/h        |
|                              |      |           | veh/h        |     | veh/h         |     |           |             |                  | veh               | m        |           |                |                     |             |
| South: Willoughby Rd (S)     |      |           |              |     |               |     |           |             |                  |                   |          |           |                |                     |             |
| 1                            | L2   | All MCs   | 91           | 3.5 | 91            | 3.5 | 0.144     | 31.0        | LOS C            | 2.4               | 17.5     | 0.72      | 0.70           | 0.72                | 24.7        |
| 2                            | T1   | All MCs   | 143          | 3.7 | 143           | 3.7 | 0.315     | 29.2        | LOS C            | 4.5               | 32.4     | 0.77      | 0.65           | 0.77                | 27.0        |
| 3                            | R2   | All MCs   | 14           | 0.0 | 14            | 0.0 | *0.315    | 37.0        | LOS C            | 4.5               | 32.4     | 0.77      | 0.65           | 0.77                | 25.5        |
| Approach                     |      |           | 247          | 3.4 | 247           | 3.4 | 0.315     | 30.3        | LOS C            | 4.5               | 32.4     | 0.75      | 0.67           | 0.75                | 26.0        |
| East: Albany St (E)          |      |           |              |     |               |     |           |             |                  |                   |          |           |                |                     |             |
| 4                            | L2   | All MCs   | 27           | 0.0 | 27            | 0.0 | 0.125     | 16.2        | LOS B            | 2.4               | 17.1     | 0.55      | 0.50           | 0.55                | 31.2        |
| 5                            | T1   | All MCs   | 308          | 0.3 | 308           | 0.3 | 0.623     | 14.0        | LOS A            | 11.1              | 78.3     | 0.77      | 0.69           | 0.77                | 28.1        |
| 6                            | R2   | All MCs   | 158          | 0.7 | 158           | 0.7 | *0.623    | 27.0        | LOS B            | 11.1              | 78.3     | 0.86      | 0.77           | 0.86                | 26.1        |
| Approach                     |      |           | 494          | 0.4 | 494           | 0.4 | 0.623     | 18.3        | LOS B            | 11.1              | 78.3     | 0.78      | 0.70           | 0.78                | 27.6        |
| North: Willoughby Rd (N)     |      |           |              |     |               |     |           |             |                  |                   |          |           |                |                     |             |
| 7                            | L2   | All MCs   | 106          | 0.0 | 106           | 0.0 | 0.127     | 18.3        | LOS B            | 2.4               | 16.8     | 0.61      | 0.70           | 0.61                | 27.3        |
| 8                            | T1   | All MCs   | 161          | 3.3 | 161           | 3.3 | 0.362     | 21.5        | LOS B            | 6.1               | 43.7     | 0.79      | 0.72           | 0.79                | 26.1        |
| 9                            | R2   | All MCs   | 46           | 0.0 | 46            | 0.0 | 0.362     | 28.9        | LOS C            | 6.1               | 43.7     | 0.79      | 0.72           | 0.79                | 24.6        |
| Approach                     |      |           | 314          | 1.7 | 314           | 1.7 | 0.362     | 21.5        | LOS B            | 6.1               | 43.7     | 0.73      | 0.71           | 0.73                | 26.2        |
| West: Albany St (W)          |      |           |              |     |               |     |           |             |                  |                   |          |           |                |                     |             |
| 10                           | L2   | All MCs   | 96           | 0.0 | 96            | 0.0 | 0.138     | 22.3        | LOS B            | 2.5               | 17.2     | 0.69      | 0.71           | 0.69                | 25.0        |
| 11                           | T1   | All MCs   | 286          | 1.1 | 286           | 1.1 | *0.371    | 18.3        | LOS B            | 7.9               | 55.8     | 0.75      | 0.64           | 0.75                | 27.8        |
| Approach                     |      |           | 382          | 0.8 | 382           | 0.8 | 0.371     | 19.3        | LOS B            | 7.9               | 55.8     | 0.74      | 0.66           | 0.74                | 27.0        |
| All Vehicles                 |      |           | 1437         | 1.3 | 1437          | 1.3 | 0.623     | 21.3        | LOS B            | 11.1              | 78.3     | 0.75      | 0.69           | 0.75                | 26.8        |

Site Level of Service (LOS) Method: Delay (RTA NSW). Site LOS Method is specified in the Parameter Settings dialog (Options tab).

Vehicle movement LOS values are based on average delay per movement.

Intersection and Approach LOS values are based on average delay for all vehicle movements.

Delay Model: SIDRA Standard (Control Delay: Geometric Delay is included).

Queue Model: SIDRA queue estimation methods are used for Back of Queue and Queue at Start of Green.

Gap-Acceptance Capacity Formula: SIDRA Standard (Akçelik M3D).

HV (%) values are calculated for All Movement Classes of All Heavy Vehicle Model Designation.

Arrival Flows used in performance calculations are adjusted to include any Initial Queued Demand and Upstream Capacity Constraint effects.

\* Critical Movement (Signal Timing)

| Pedestrian Movement Performance |          |            |           |             |                  |                       |        |           |                |             |              |             |
|---------------------------------|----------|------------|-----------|-------------|------------------|-----------------------|--------|-----------|----------------|-------------|--------------|-------------|
| Mov ID                          | Crossing | Input Vol. | Dem. Flow | Aver. Delay | Level of Service | AVERAGE BACK OF QUEUE |        | Prop. Que | Eff. Stop Rate | Travel Time | Travel Dist. | Aver. Speed |
|                                 |          | ped/h      | ped/h     | sec         |                  | [ Ped                 | Dist ] |           |                | sec         | m            | m/sec       |
|                                 |          |            |           |             |                  | ped                   | m      |           |                |             |              |             |
| South: Willoughby Rd (S)        |          |            |           |             |                  |                       |        |           |                |             |              |             |
| P1                              | Full     | 42         | 44        | 29.8        | LOS C            | 0.1                   | 0.1    | 0.86      | 0.86           | 46.5        | 20.0         | 0.43        |
| East: Albany St (E)             |          |            |           |             |                  |                       |        |           |                |             |              |             |
| P2                              | Full     | 107        | 113       | 29.9        | LOS C            | 0.2                   | 0.2    | 0.87      | 0.87           | 46.6        | 20.0         | 0.43        |
| North: Willoughby Rd (N)        |          |            |           |             |                  |                       |        |           |                |             |              |             |
| P3                              | Full     | 59         | 62        | 29.8        | LOS C            | 0.1                   | 0.1    | 0.86      | 0.86           | 46.5        | 20.0         | 0.43        |
| West: Albany St (W)             |          |            |           |             |                  |                       |        |           |                |             |              |             |
| P4                              | Full     | 15         | 16        | 29.8        | LOS C            | 0.0                   | 0.0    | 0.86      | 0.86           | 46.4        | 20.0         | 0.43        |
| All Pedestrians                 |          | 223        | 235       | 29.9        | LOS C            | 0.2                   | 0.2    | 0.87      | 0.87           | 46.5        | 20.0         | 0.43        |

Level of Service (LOS) Method: SIDRA Pedestrian LOS Method (Based on Average Delay)

Pedestrian movement LOS values are based on average delay per pedestrian movement.

Intersection LOS value for Pedestrians is based on average delay for all pedestrian movements.

**SIDRA INTERSECTION 9.1 | Copyright © 2000-2022 Kcelik and Associates Pty Ltd | sidrasolutions.com**

Organisation: AECOM AUSTRALIA PTY LTD | Licence: NETWORK / Enterprise Level 1 | Processed: Thursday, 13 July 2023 6:24:48 PM

Project: C:\Users\YeungM\AECOM\ANZ-NAC-Sydney Metro-Sydney Metro C&SW Operational Monitoring - General\400\_Technical\432\_Traffic Analysis\SIDRA Modelling\01 Models (Geometry Only)\Block 1\Rev1\\_Review\02 SM C&SW\_CST (Block 1)\_PS.sip9

# MOVEMENT SUMMARY

Site: CST09 [CST09 Albany St / Oxley St (Site Folder: Block 1 Model - 2023 Weekend Peak)]

Output produced by SIDRA INTERSECTION Version: 9.1.1.200

Network: CST-N1 [CST Network 1 (Network Folder: Block 1 Network - 2023 Weekend Peak)]

NA  
Site Category: (None)  
Roundabout

| Vehicle Movement Performance |      |           |                       |     |                       |     |           |             |                  |                   |             |           |                |                     |                  |
|------------------------------|------|-----------|-----------------------|-----|-----------------------|-----|-----------|-------------|------------------|-------------------|-------------|-----------|----------------|---------------------|------------------|
| Mov ID                       | Turn | Mov Class | Demand Flows          |     | Arrival Flows         |     | Deg. Satn | Aver. Delay | Level of Service | 95% Back Of Queue |             | Prop. Que | Eff. Stop Rate | Aver. No. of Cycles | Aver. Speed km/h |
|                              |      |           | [ Total HV ]<br>veh/h | %   | [ Total HV ]<br>veh/h | %   |           |             |                  | [ Veh. veh        | Dist ]<br>m |           |                |                     |                  |
| South: Oxley St (S)          |      |           |                       |     |                       |     |           |             |                  |                   |             |           |                |                     |                  |
| 1                            | L2   | All MCs   | 69                    | 0.0 | 69                    | 0.0 | 0.295     | 7.9         | LOS A            | 2.0               | 13.8        | 0.73      | 0.65           | 0.73                | 22.0             |
| 2                            | T1   | All MCs   | 103                   | 0.0 | 103                   | 0.0 | 0.295     | 7.7         | LOS A            | 2.0               | 13.8        | 0.73      | 0.65           | 0.73                | 33.2             |
| 3                            | R2   | All MCs   | 39                    | 2.7 | 39                    | 2.7 | 0.295     | 10.7        | LOS A            | 2.0               | 13.8        | 0.73      | 0.65           | 0.73                | 31.0             |
| 3u                           | U    | All MCs   | 3                     | 0.0 | 3                     | 0.0 | 0.295     | 12.0        | LOS A            | 2.0               | 13.8        | 0.73      | 0.65           | 0.73                | 22.0             |
| Approach                     |      |           | 215                   | 0.5 | 215                   | 0.5 | 0.295     | 8.4         | LOS A            | 2.0               | 13.8        | 0.73      | 0.65           | 0.73                | 30.4             |
| East: Albany St (E)          |      |           |                       |     |                       |     |           |             |                  |                   |             |           |                |                     |                  |
| 4                            | L2   | All MCs   | 52                    | 0.0 | 52                    | 0.0 | 0.547     | 7.7         | LOS A            | 3.7               | 26.1        | 0.60      | 0.69           | 0.65                | 30.8             |
| 5                            | T1   | All MCs   | 344                   | 0.6 | 344                   | 0.6 | 0.547     | 7.5         | LOS A            | 3.7               | 26.1        | 0.60      | 0.69           | 0.65                | 30.8             |
| 6                            | R2   | All MCs   | 21                    | 0.0 | 21                    | 0.0 | 0.547     | 10.4        | LOS A            | 3.7               | 26.1        | 0.60      | 0.69           | 0.65                | 35.7             |
| 6u                           | U    | All MCs   | 8                     | 0.0 | 8                     | 0.0 | 0.547     | 11.8        | LOS A            | 3.7               | 26.1        | 0.60      | 0.69           | 0.65                | 35.1             |
| Approach                     |      |           | 425                   | 0.5 | 425                   | 0.5 | 0.547     | 7.7         | LOS A            | 3.7               | 26.1        | 0.60      | 0.69           | 0.65                | 31.3             |
| North: Oxley St (N)          |      |           |                       |     |                       |     |           |             |                  |                   |             |           |                |                     |                  |
| 7                            | L2   | All MCs   | 44                    | 0.0 | 44                    | 0.0 | 0.353     | 8.3         | LOS A            | 2.3               | 16.2        | 0.77      | 0.70           | 0.77                | 34.8             |
| 8                            | T1   | All MCs   | 115                   | 0.0 | 115                   | 0.0 | 0.353     | 8.1         | LOS A            | 2.3               | 16.2        | 0.77      | 0.70           | 0.77                | 30.2             |
| 9                            | R2   | All MCs   | 79                    | 1.3 | 79                    | 1.3 | 0.353     | 11.0        | LOS A            | 2.3               | 16.2        | 0.77      | 0.70           | 0.77                | 30.2             |
| 9u                           | U    | All MCs   | 7                     | 0.0 | 7                     | 0.0 | 0.353     | 12.3        | LOS A            | 2.3               | 16.2        | 0.77      | 0.70           | 0.77                | 35.0             |
| Approach                     |      |           | 245                   | 0.4 | 245                   | 0.4 | 0.353     | 9.2         | LOS A            | 2.3               | 16.2        | 0.77      | 0.70           | 0.77                | 31.5             |
| West: Albany St (W)          |      |           |                       |     |                       |     |           |             |                  |                   |             |           |                |                     |                  |
| 10                           | L2   | All MCs   | 107                   | 1.0 | 107                   | 1.0 | 0.510     | 5.8         | LOS A            | 4.6               | 32.5        | 0.62      | 0.55           | 0.62                | 35.0             |
| 11                           | T1   | All MCs   | 339                   | 2.5 | 339                   | 2.5 | 0.510     | 5.7         | LOS A            | 4.6               | 32.5        | 0.62      | 0.55           | 0.62                | 34.8             |
| 12                           | R2   | All MCs   | 89                    | 1.2 | 89                    | 1.2 | 0.510     | 8.5         | LOS A            | 4.6               | 32.5        | 0.62      | 0.55           | 0.62                | 26.9             |
| 12u                          | U    | All MCs   | 11                    | 0.0 | 11                    | 0.0 | 0.510     | 9.9         | LOS A            | 4.6               | 32.5        | 0.62      | 0.55           | 0.62                | 26.9             |
| Approach                     |      |           | 546                   | 1.9 | 546                   | 1.9 | 0.510     | 6.2         | LOS A            | 4.6               | 32.5        | 0.62      | 0.55           | 0.62                | 34.0             |
| All Vehicles                 |      |           | 1432                  | 1.0 | 1432                  | 1.0 | 0.547     | 7.5         | LOS A            | 4.6               | 32.5        | 0.66      | 0.63           | 0.67                | 32.3             |

Site Level of Service (LOS) Method: Delay (RTA NSW). Site LOS Method is specified in the Network Data dialog (Override Site Data tab).

Vehicle movement LOS values are based on average delay per movement.

Intersection and Approach LOS values are based on average delay for all vehicle movements.

Roundabout Capacity Model: SIDRA Standard.

Delay Model: SIDRA Standard (Control Delay: Geometric Delay is included).

Queue Model: SIDRA queue estimation methods are used for Back of Queue and Queue at Start of Gap.

Gap-Acceptance Capacity Formula: SIDRA Standard (Akçelik M3D).

HV (%) values are calculated for All Movement Classes of All Heavy Vehicle Model Designation.

Arrival Flows used in performance calculations are adjusted to include any Initial Queued Demand and Upstream Capacity Constraint effects.

---

**SIDRA INTERSECTION 9.1 | Copyright © 2000-2022 Akcelik and Associates Pty Ltd | sidrasolutions.com**

Organisation: AECOM AUSTRALIA PTY LTD | Licence: NETWORK / Enterprise Level 1 | Processed: Monday, 17 July 2023 1:41:44 PM

Project: C:\Users\Yeung\AECOM\ANZ-NAC-Sydney Metro-Sydney Metro C&SW Operational Monitoring - General\400\_Technical\432\_Traffic Analysis\SIDRA Modelling\01 Models (Geometry Only)\Block 1\Rev1\\_Review\02 SM C&SW\_CST (Block 1)\_PS.sip9



# MOVEMENT SUMMARY

Site: CST10 [CST10 Albany St / Clarke Ln (Site Folder: Block 1 Model - 2023 Weekend Peak)]

Output produced by SIDRA INTERSECTION Version: 9.1.1.200

Network: CST-N1 [CST Network 1 (Network Folder: Block 1 Network - 2023 Weekend Peak)]

NA  
 Site Category: (None)  
 Give-Way (Two-Way)

| Vehicle Movement Performance |      |           |                       |     |                       |     |           |             |                  |                   |               |           |                |                     |                  |
|------------------------------|------|-----------|-----------------------|-----|-----------------------|-----|-----------|-------------|------------------|-------------------|---------------|-----------|----------------|---------------------|------------------|
| Mov ID                       | Turn | Mov Class | Demand Flows          |     | Arrival Flows         |     | Deg. Satn | Aver. Delay | Level of Service | 95% Back Of Queue |               | Prop. Que | Eff. Stop Rate | Aver. No. of Cycles | Aver. Speed km/h |
|                              |      |           | [ Total HV ]<br>veh/h | %   | [ Total HV ]<br>veh/h | %   |           |             |                  | [ Veh. veh        | [ Dist ]<br>m |           |                |                     |                  |
| SouthEast: Clarke Ln (SE)    |      |           |                       |     |                       |     |           |             |                  |                   |               |           |                |                     |                  |
| 21a                          | L1   | All MCs   | 27                    | 0.0 | 27                    | 0.0 | 0.054     | 4.2         | LOS A            | 6.5               | 45.4          | 0.17      | 0.50           | 0.17                | 31.8             |
| 23b                          | R3   | All MCs   | 4                     | 0.0 | 4                     | 0.0 | 0.054     | 14.5        | LOS B            | 6.5               | 45.4          | 0.17      | 0.50           | 0.17                | 31.8             |
| Approach                     |      |           | 32                    | 0.0 | 32                    | 0.0 | 0.054     | 5.6         | LOS A            | 6.5               | 45.4          | 0.17      | 0.50           | 0.17                | 31.8             |
| East: Albany St (E)          |      |           |                       |     |                       |     |           |             |                  |                   |               |           |                |                     |                  |
| 5                            | T1   | All MCs   | 503                   | 0.6 | 503                   | 0.6 | 0.236     | 0.0         | LOS A            | 13.0              | 91.6          | 0.00      | 0.00           | 0.00                | 49.9             |
| Approach                     |      |           | 503                   | 0.6 | 503                   | 0.6 | 0.236     | 0.0         | NA               | 13.0              | 91.6          | 0.00      | 0.00           | 0.00                | 49.9             |
| West: Albany St (W)          |      |           |                       |     |                       |     |           |             |                  |                   |               |           |                |                     |                  |
| 11                           | T1   | All MCs   | 519                   | 2.0 | 519                   | 2.0 | 0.272     | 0.0         | LOS A            | 0.0               | 0.0           | 0.00      | 0.00           | 0.00                | 49.9             |
| Approach                     |      |           | 519                   | 2.0 | 519                   | 2.0 | 0.272     | 0.0         | NA               | 0.0               | 0.0           | 0.00      | 0.00           | 0.00                | 49.9             |
| All Vehicles                 |      |           | 1054                  | 1.3 | 1054                  | 1.3 | 0.272     | 0.2         | NA               | 13.0              | 91.6          | 0.01      | 0.01           | 0.01                | 48.4             |

Site Level of Service (LOS) Method: Delay (RTA NSW). Site LOS Method is specified in the Network Data dialog (Override Site Data tab).

Vehicle movement LOS values are based on average delay per movement.

Minor Road Approach LOS values are based on average delay for all vehicle movements.

NA (TWSC): Level of Service is not defined for major road approaches or the intersection as a whole for Two-Way Sign Control (HCM LOS rule).

Two-Way Sign Control Capacity Model: SIDRA Standard.

Delay Model: SIDRA Standard (Control Delay: Geometric Delay is included).

Queue Model: SIDRA queue estimation methods are used for Back of Queue and Queue at Start of Gap.

Gap-Acceptance Capacity Formula: SIDRA Standard (Akçelik M3D).

HV (%) values are calculated for All Movement Classes of All Heavy Vehicle Model Designation.

Arrival Flows used in performance calculations are adjusted to include any Initial Queued Demand and Upstream Capacity Constraint effects.

---

**SIDRA INTERSECTION 9.1 | Copyright © 2000-2022 Akcelik and Associates Pty Ltd | sidrasolutions.com**

Organisation: AECOM AUSTRALIA PTY LTD | Licence: NETWORK / Enterprise Level 1 | Processed: Monday, 17 July 2023 1:41:44 PM

Project: C:\Users\Yeung\AECOM\ANZ-NAC-Sydney Metro-Sydney Metro C&SW Operational Monitoring - General\400\_Technical\432\_Traffic Analysis\SIDRA Modelling\01 Models (Geometry Only)\Block 1\Rev1\\_Review\02 SM C&SW\_CST (Block 1)\_PS.sip9

# MOVEMENT SUMMARY

Site: CST11 [CST11 Oxley St / Clarke Ln (Site Folder: Block 1 Model - 2023 Weekend Peak)]

Output produced by SIDRA INTERSECTION Version: 9.1.1.200

Network: CST-N1 [CST Network 1 (Network Folder: Block 1 Network - 2023 Weekend Peak)]

NA  
Site Category: (None)  
Give-Way (Two-Way)

| Vehicle Movement Performance |      |           |                       |       |                       |       |           |             |                  |                   |             |           |                |                     |                  |
|------------------------------|------|-----------|-----------------------|-------|-----------------------|-------|-----------|-------------|------------------|-------------------|-------------|-----------|----------------|---------------------|------------------|
| Mov ID                       | Turn | Mov Class | Demand Flows          |       | Arrival Flows         |       | Deg. Satn | Aver. Delay | Level of Service | 95% Back Of Queue |             | Prop. Que | Eff. Stop Rate | Aver. No. of Cycles | Aver. Speed km/h |
|                              |      |           | [ Total HV ]<br>veh/h | %     | [ Total HV ]<br>veh/h | %     |           |             |                  | [ Veh. veh        | Dist ]<br>m |           |                |                     |                  |
| SouthEast: Clarke Ln (SE)    |      |           |                       |       |                       |       |           |             |                  |                   |             |           |                |                     |                  |
| 1                            | L2   | All MCs   | 1                     | 100.0 | 1                     | 100.0 | 0.008     | 6.0         | LOS A            | 0.0               | 0.2         | 0.33      | 0.53           | 0.33                | 31.6             |
| 2                            | T1   | All MCs   | 1                     | 0.0   | 1                     | 0.0   | 0.008     | 4.7         | LOS A            | 0.0               | 0.2         | 0.33      | 0.53           | 0.33                | 31.6             |
| 3                            | R2   | All MCs   | 4                     | 0.0   | 4                     | 0.0   | 0.008     | 6.2         | LOS A            | 0.0               | 0.2         | 0.33      | 0.53           | 0.33                | 31.6             |
| Approach                     |      |           | 6                     | 16.7  | 6                     | 16.7  | 0.008     | 5.9         | LOS A            | 0.0               | 0.2         | 0.33      | 0.53           | 0.33                | 31.6             |
| NorthEast: Oxley St (NE)     |      |           |                       |       |                       |       |           |             |                  |                   |             |           |                |                     |                  |
| 4                            | L2   | All MCs   | 2                     | 0.0   | 2                     | 0.0   | 0.132     | 3.0         | LOS A            | 0.1               | 0.4         | 0.03      | 0.03           | 0.03                | 42.9             |
| 5                            | T1   | All MCs   | 172                   | 0.6   | 172                   | 0.6   | 0.132     | 0.0         | LOS A            | 0.1               | 0.4         | 0.03      | 0.03           | 0.03                | 47.0             |
| 6                            | R2   | All MCs   | 5                     | 0.0   | 5                     | 0.0   | 0.132     | 3.8         | LOS A            | 0.1               | 0.4         | 0.03      | 0.03           | 0.03                | 47.0             |
| Approach                     |      |           | 179                   | 0.6   | 179                   | 0.6   | 0.132     | 0.1         | NA               | 0.1               | 0.4         | 0.03      | 0.03           | 0.03                | 46.8             |
| NorthWest: Clarke Ln (NW)    |      |           |                       |       |                       |       |           |             |                  |                   |             |           |                |                     |                  |
| 7                            | L2   | All MCs   | 13                    | 0.0   | 13                    | 0.0   | 0.021     | 5.0         | LOS A            | 0.1               | 0.5         | 0.30      | 0.52           | 0.30                | 25.1             |
| 8                            | T1   | All MCs   | 1                     | 0.0   | 1                     | 0.0   | 0.021     | 4.6         | LOS A            | 0.1               | 0.5         | 0.30      | 0.52           | 0.30                | 34.2             |
| 9                            | R2   | All MCs   | 7                     | 0.0   | 7                     | 0.0   | 0.021     | 6.2         | LOS A            | 0.1               | 0.5         | 0.30      | 0.52           | 0.30                | 25.1             |
| Approach                     |      |           | 21                    | 0.0   | 21                    | 0.0   | 0.021     | 5.4         | LOS A            | 0.1               | 0.5         | 0.30      | 0.52           | 0.30                | 25.9             |
| SouthWest: Oxley St (SW)     |      |           |                       |       |                       |       |           |             |                  |                   |             |           |                |                     |                  |
| 10                           | L2   | All MCs   | 1                     | 0.0   | 1                     | 0.0   | 0.091     | 3.0         | LOS A            | 0.0               | 0.1         | 0.00      | 0.01           | 0.00                | 49.2             |
| 11                           | T1   | All MCs   | 173                   | 1.8   | 173                   | 1.8   | 0.091     | 0.0         | LOS A            | 0.0               | 0.1         | 0.00      | 0.01           | 0.00                | 49.2             |
| 12                           | R2   | All MCs   | 1                     | 0.0   | 1                     | 0.0   | 0.091     | 3.1         | LOS A            | 0.0               | 0.1         | 0.00      | 0.01           | 0.00                | 42.9             |
| Approach                     |      |           | 175                   | 1.8   | 175                   | 1.8   | 0.091     | 0.0         | NA               | 0.0               | 0.1         | 0.00      | 0.01           | 0.00                | 49.0             |
| All Vehicles                 |      |           | 381                   | 1.4   | 381                   | 1.4   | 0.132     | 0.5         | NA               | 0.1               | 0.5         | 0.04      | 0.06           | 0.04                | 43.0             |

Site Level of Service (LOS) Method: Delay (RTA NSW). Site LOS Method is specified in the Network Data dialog (Override Site Data tab).

Vehicle movement LOS values are based on average delay per movement.

Minor Road Approach LOS values are based on average delay for all vehicle movements.

NA (TWSC): Level of Service is not defined for major road approaches or the intersection as a whole for Two-Way Sign Control (HCM LOS rule).

Two-Way Sign Control Capacity Model: SIDRA Standard.

Delay Model: SIDRA Standard (Control Delay: Geometric Delay is included).

Queue Model: SIDRA queue estimation methods are used for Back of Queue and Queue at Start of Gap.

Gap-Acceptance Capacity Formula: SIDRA Standard (Akçelik M3D).

HV (%) values are calculated for All Movement Classes of All Heavy Vehicle Model Designation.

Arrival Flows used in performance calculations are adjusted to include any Initial Queued Demand and Upstream Capacity Constraint effects.

---

**SIDRA INTERSECTION 9.1 | Copyright © 2000-2022 Akcelik and Associates Pty Ltd | sidrasolutions.com**

Organisation: AECOM AUSTRALIA PTY LTD | Licence: NETWORK / Enterprise Level 1 | Processed: Monday, 17 July 2023 1:41:44 PM

Project: C:\Users\Yeung\AECOM\ANZ-NAC-Sydney Metro-Sydney Metro C&SW Operational Monitoring - General\400\_Technical\432\_Traffic Analysis\SIDRA Modelling\01 Models (Geometry Only)\Block 1\Rev1\\_Review\02 SM C&SW\_CST (Block 1)\_PS.sip9

# MOVEMENT SUMMARY

 Site: CST12 [CST12 Hume St / Clarke Ln (Site Folder: Block 1 Model - 2023 Weekend Peak)]

Output produced by SIDRA INTERSECTION Version: 9.1.1.200

■ Network: CST-N1 [CST Network 1 (Network Folder: Block 1 Network - 2023 Weekend Peak)]

NA  
Site Category: (None)  
Stop (Two-Way)

| Vehicle Movement Performance |      |           |                       |     |                       |     |           |             |                  |                   |             |           |                |                     |                  |
|------------------------------|------|-----------|-----------------------|-----|-----------------------|-----|-----------|-------------|------------------|-------------------|-------------|-----------|----------------|---------------------|------------------|
| Mov ID                       | Turn | Mov Class | Demand Flows          |     | Arrival Flows         |     | Deg. Satn | Aver. Delay | Level of Service | 95% Back Of Queue |             | Prop. Que | Eff. Stop Rate | Aver. No. of Cycles | Aver. Speed km/h |
|                              |      |           | [ Total HV ]<br>veh/h | %   | [ Total HV ]<br>veh/h | %   |           |             |                  | [ Veh. veh        | Dist ]<br>m |           |                |                     |                  |
| SouthEast: Clarke Ln (SE)    |      |           |                       |     |                       |     |           |             |                  |                   |             |           |                |                     |                  |
| 3                            | R2   | All MCs   | 2                     | 0.0 | 2                     | 0.0 | 0.001     | 6.9         | LOS A            | 0.0               | 0.0         | 0.00      | 1.00           | 0.00                | 27.8             |
| Approach                     |      |           | 2                     | 0.0 | 2                     | 0.0 | 0.001     | 6.9         | LOS A            | 0.0               | 0.0         | 0.00      | 1.00           | 0.00                | 27.8             |
| NorthEast: Hume St (NE)      |      |           |                       |     |                       |     |           |             |                  |                   |             |           |                |                     |                  |
| 4                            | L2   | All MCs   | 1                     | 0.0 | 1                     | 0.0 | 0.001     | 3.2         | LOS A            | 0.0               | 0.0         | 0.00      | 0.50           | 0.00                | 34.8             |
| Approach                     |      |           | 1                     | 0.0 | 1                     | 0.0 | 0.001     | 3.2         | NA               | 0.0               | 0.0         | 0.00      | 0.50           | 0.00                | 34.8             |
| All Vehicles                 |      |           | 3                     | 0.0 | 3                     | 0.0 | 0.001     | 5.7         | NA               | 0.0               | 0.0         | 0.00      | 0.83           | 0.00                | 30.2             |

Site Level of Service (LOS) Method: Delay (RTA NSW). Site LOS Method is specified in the Network Data dialog (Override Site Data tab).

Vehicle movement LOS values are based on average delay per movement.

Minor Road Approach LOS values are based on average delay for all vehicle movements.

NA (TWSC): Level of Service is not defined for major road approaches or the intersection as a whole for Two-Way Sign Control (HCM LOS rule).

Two-Way Sign Control Capacity Model: SIDRA Standard.

Delay Model: SIDRA Standard (Control Delay: Geometric Delay is included).

Queue Model: SIDRA queue estimation methods are used for Back of Queue and Queue at Start of Gap.

Gap-Acceptance Capacity Formula: SIDRA Standard (Akçelik M3D).

HV (%) values are calculated for All Movement Classes of All Heavy Vehicle Model Designation.

Arrival Flows used in performance calculations are adjusted to include any Initial Queued Demand and Upstream Capacity Constraint effects.

---

**SIDRA INTERSECTION 9.1 | Copyright © 2000-2022 Akcelik and Associates Pty Ltd | sidrasolutions.com**

Organisation: AECOM AUSTRALIA PTY LTD | Licence: NETWORK / Enterprise Level 1 | Processed: Monday, 17 July 2023 1:41:44 PM

Project: C:\Users\Yeung\AECOM\ANZ-NAC-Sydney Metro-Sydney Metro C&SW Operational Monitoring - General\400\_Technical\432\_Traffic Analysis\SIDRA Modelling\01 Models (Geometry Only)\Block 1\Rev1\\_Review\02 SM C&SW\_CST (Block 1)\_PS.sip9

# MOVEMENT SUMMARY

Site: CST13 [CST13 Pacific Hwy / Alexander St (Site Folder: Block 1 Model - 2023 Weekend Peak)]

Output produced by SIDRA INTERSECTION Version: 9.1.1.200

Network: CST-N1 [CST Network 1 (Network Folder: Block 1 Network - 2023 Weekend Peak)]

TCS 763

Site Category: (None)

Signals - EQUISAT (Fixed-Time/SCATS) Coordinated Cycle Time = 130 seconds (Network User-Given Cycle Time)

| Vehicle Movement Performance |      |           |                       |      |                       |      |           |             |                  |                   |               |           |                |                     |             |
|------------------------------|------|-----------|-----------------------|------|-----------------------|------|-----------|-------------|------------------|-------------------|---------------|-----------|----------------|---------------------|-------------|
| Mov ID                       | Turn | Mov Class | Demand Flows          |      | Arrival Flows         |      | Deg. Satn | Aver. Delay | Level of Service | 95% Back Of Queue |               | Prop. Que | Eff. Stop Rate | Aver. No. of Cycles | Aver. Speed |
|                              |      |           | [ Total HV ]<br>veh/h | %    | [ Total HV ]<br>veh/h | %    |           |             |                  | [ Veh. veh        | [ Dist ]<br>m |           |                |                     |             |
| SouthEast: Pacific Hwy (SE)  |      |           |                       |      |                       |      |           |             |                  |                   |               |           |                |                     |             |
| 2                            | T1   | All MCs   | 825                   | 2.2  | 825                   | 2.2  | *0.419    | 10.6        | LOS A            | 8.8               | 62.4          | 0.66      | 0.57           | 0.66                | 32.0        |
| 3a                           | R1   | All MCs   | 193                   | 2.7  | 193                   | 2.7  | 0.281     | 14.0        | LOS A            | 5.1               | 36.8          | 0.53      | 0.68           | 0.53                | 28.5        |
| Approach                     |      |           | 1018                  | 2.3  | 1018                  | 2.3  | 0.419     | 11.2        | LOS A            | 8.8               | 62.4          | 0.64      | 0.59           | 0.64                | 31.2        |
| North: Alexander St (N)      |      |           |                       |      |                       |      |           |             |                  |                   |               |           |                |                     |             |
| 24a                          | L1   | All MCs   | 189                   | 1.1  | 189                   | 1.1  | *0.343    | 28.7        | LOS C            | 6.1               | 43.1          | 0.98      | 0.80           | 0.98                | 21.1        |
| 26b                          | R3   | All MCs   | 111                   | 0.0  | 111                   | 0.0  | *0.421    | 68.4        | LOS E            | 7.1               | 49.5          | 1.00      | 0.83           | 1.00                | 5.0         |
| Approach                     |      |           | 300                   | 0.7  | 300                   | 0.7  | 0.421     | 43.3        | LOS D            | 7.1               | 49.5          | 0.99      | 0.81           | 0.99                | 13.5        |
| NorthWest: Pacific Hwy (NW)  |      |           |                       |      |                       |      |           |             |                  |                   |               |           |                |                     |             |
| 7b                           | L3   | All MCs   | 18                    | 47.1 | 18                    | 47.1 | 0.048     | 19.5        | LOS B            | 0.4               | 4.0           | 0.44      | 0.58           | 0.44                | 25.7        |
| 8                            | T1   | All MCs   | 673                   | 2.2  | 673                   | 2.2  | 0.341     | 10.6        | LOS A            | 6.0               | 42.6          | 0.55      | 0.47           | 0.55                | 41.9        |
| Approach                     |      |           | 691                   | 3.4  | 691                   | 3.4  | 0.341     | 10.8        | LOS A            | 6.0               | 42.6          | 0.54      | 0.47           | 0.54                | 41.6        |
| All Vehicles                 |      |           | 2008                  | 2.4  | 2008                  | 2.4  | 0.421     | 15.9        | LOS B            | 8.8               | 62.4          | 0.66      | 0.58           | 0.66                | 29.3        |

Site Level of Service (LOS) Method: Delay (RTA NSW). Site LOS Method is specified in the Network Data dialog (Override Site Data tab).

Vehicle movement LOS values are based on average delay per movement.

Intersection and Approach LOS values are based on average delay for all vehicle movements.

Delay Model: SIDRA Standard (Control Delay: Geometric Delay is included).

Queue Model: SIDRA queue estimation methods are used for Back of Queue and Queue at Start of Green.

Gap-Acceptance Capacity Formula: SIDRA Standard (Akçelik M3D).

HV (%) values are calculated for All Movement Classes of All Heavy Vehicle Model Designation.

Arrival Flows used in performance calculations are adjusted to include any Initial Queued Demand and Upstream Capacity Constraint effects.

\* Critical Movement (Signal Timing)



| Pedestrian Movement Performance |          |           |             |                  |                       |        |           |                |             |              |             |
|---------------------------------|----------|-----------|-------------|------------------|-----------------------|--------|-----------|----------------|-------------|--------------|-------------|
| Mov ID                          | Crossing | Dem. Flow | Aver. Delay | Level of Service | AVERAGE BACK OF QUEUE |        | Prop. Que | Eff. Stop Rate | Travel Time | Travel Dist. | Aver. Speed |
|                                 |          | ped/h     | sec         |                  | [ Ped                 | Dist ] |           |                | sec         | m            | m/sec       |
|                                 |          |           |             |                  | ped                   | m      |           |                |             |              |             |
| North: Alexander St (N)         |          |           |             |                  |                       |        |           |                |             |              |             |
| P6                              | Full     | 36        | 21.0        | LOS C            | 0.1                   | 0.1    | 0.80      | 0.80           | 37.7        | 20.0         | 0.53        |
| NorthWest: Pacific Hwy (NW)     |          |           |             |                  |                       |        |           |                |             |              |             |
| P3                              | Full     | 65        | 52.8        | LOS E            | 0.2                   | 0.2    | 0.90      | 0.90           | 69.5        | 20.0         | 0.29        |
| All Pedestrians                 |          | 101       | 41.5        | LOS E            | 0.2                   | 0.2    | 0.87      | 0.87           | 58.2        | 20.0         | 0.34        |

Level of Service (LOS) Method: SIDRA Pedestrian LOS Method (Based on Average Delay)

Pedestrian movement LOS values are based on average delay per pedestrian movement.

Intersection LOS value for Pedestrians is based on average delay for all pedestrian movements.

---

**SIDRA INTERSECTION 9.1 | Copyright © 2000-2022 Akcelik and Associates Pty Ltd | sidrasolutions.com**

Organisation: AECOM AUSTRALIA PTY LTD | Licence: NETWORK / Enterprise Level 1 | Processed: Monday, 17 July 2023 1:41:44 PM

Project: C:\Users\YeungM\AECOM\ANZ-NAC-Sydney Metro-Sydney Metro C&SW Operational Monitoring - General\400\_Technical\432\_Traffic Analysis\SIDRA Modelling\01 Models (Geometry Only)\Block 1\Rev1\_Review\02 SM C&SW\_CST (Block 1)\_PS.sip9

# MOVEMENT SUMMARY

Site: CST14 [CST14 Falcon St / Alexander St (Site Folder: Block 1 Model - 2023 Weekend Peak)]

Output produced by SIDRA INTERSECTION Version: 9.1.1.200

Network: CST-N1 [CST Network 1 (Network Folder: Block 1 Network - 2023 Weekend Peak)]

TCS 764

Site Category: (None)

Signals - EQUISAT (Fixed-Time/SCATS) Coordinated Cycle Time = 130 seconds (Network User-Given Cycle Time)

| Vehicle Movement Performance |      |           |                       |       |                       |       |           |             |                  |                   |               |           |                |                     |                  |
|------------------------------|------|-----------|-----------------------|-------|-----------------------|-------|-----------|-------------|------------------|-------------------|---------------|-----------|----------------|---------------------|------------------|
| Mov ID                       | Turn | Mov Class | Demand Flows          |       | Arrival Flows         |       | Deg. Satn | Aver. Delay | Level of Service | 95% Back Of Queue |               | Prop. Que | Eff. Stop Rate | Aver. No. of Cycles | Aver. Speed km/h |
|                              |      |           | [ Total HV ]<br>veh/h | %     | [ Total HV ]<br>veh/h | %     |           |             |                  | [ Veh. veh        | [ Dist ]<br>m |           |                |                     |                  |
| South: Alexander St (S)      |      |           |                       |       |                       |       |           |             |                  |                   |               |           |                |                     |                  |
| 1                            | L2   | All MCs   | 25                    | 33.3  | 25                    | 33.3  | 0.634     | 62.9        | LOS E            | 10.1              | 76.0          | 0.98      | 0.81           | 0.98                | 5.9              |
| 2                            | T1   | All MCs   | 143                   | 3.7   | 143                   | 3.7   | 0.634     | 54.3        | LOS D            | 10.1              | 76.0          | 0.98      | 0.81           | 0.98                | 10.0             |
| 3                            | R2   | All MCs   | 46                    | 0.0   | 46                    | 0.0   | 0.825     | 82.2        | LOS F            | 3.3               | 23.1          | 1.00      | 0.87           | 1.37                | 15.5             |
| Approach                     |      |           | 215                   | 6.4   | 215                   | 6.4   | 0.825     | 61.3        | LOS E            | 10.1              | 76.0          | 0.98      | 0.82           | 1.06                | 11.4             |
| East: Falcon St (E)          |      |           |                       |       |                       |       |           |             |                  |                   |               |           |                |                     |                  |
| 4                            | L2   | All MCs   | 28                    | 0.0   | 28                    | 0.0   | 0.633     | 7.2         | LOS A            | 5.6               | 39.6          | 0.13      | 0.15           | 0.13                | 56.0             |
| 5                            | T1   | All MCs   | 819                   | 1.7   | 819                   | 1.7   | 0.633     | 1.6         | LOS A            | 5.6               | 39.6          | 0.16      | 0.16           | 0.16                | 55.8             |
| 6                            | R2   | All MCs   | 4                     | 100.0 | 4                     | 100.0 | 0.633     | 14.0        | LOS A            | 4.3               | 30.9          | 0.18      | 0.17           | 0.18                | 50.2             |
| Approach                     |      |           | 852                   | 2.1   | 852                   | 2.1   | 0.633     | 1.9         | LOS A            | 5.6               | 39.6          | 0.16      | 0.16           | 0.16                | 55.8             |
| North: Alexander St (N)      |      |           |                       |       |                       |       |           |             |                  |                   |               |           |                |                     |                  |
| 7                            | L2   | All MCs   | 36                    | 0.0   | 36                    | 0.0   | 0.183     | 91.0        | LOS F            | 2.9               | 20.5          | 0.91      | 0.72           | 0.91                | 20.4             |
| 8                            | T1   | All MCs   | 295                   | 0.7   | 295                   | 0.7   | *0.914    | 104.7       | LOS F            | 20.4              | 143.8         | 0.99      | 1.08           | 1.29                | 4.8              |
| Approach                     |      |           | 331                   | 0.6   | 331                   | 0.6   | 0.914     | 103.2       | LOS F            | 20.4              | 143.8         | 0.99      | 1.05           | 1.25                | 6.7              |
| West: Falcon St (W)          |      |           |                       |       |                       |       |           |             |                  |                   |               |           |                |                     |                  |
| 10                           | L2   | All MCs   | 233                   | 0.9   | 233                   | 0.9   | *0.894    | 39.9        | LOS C            | 11.2              | 79.2          | 0.46      | 0.85           | 0.75                | 12.4             |
| 11                           | T1   | All MCs   | 751                   | 2.9   | 751                   | 2.9   | 0.542     | 0.5         | LOS A            | 2.6               | 18.3          | 0.06      | 0.05           | 0.06                | 59.0             |
| Approach                     |      |           | 983                   | 2.5   | 983                   | 2.5   | 0.894     | 9.8         | LOS A            | 11.2              | 79.2          | 0.15      | 0.24           | 0.22                | 42.4             |
| All Vehicles                 |      |           | 2380                  | 2.4   | 2380                  | 2.4   | 0.914     | 24.6        | LOS B            | 20.4              | 143.8         | 0.34      | 0.38           | 0.42                | 30.9             |

Site Level of Service (LOS) Method: Delay (RTA NSW). Site LOS Method is specified in the Network Data dialog (Override Site Data tab).

Vehicle movement LOS values are based on average delay per movement.

Intersection and Approach LOS values are based on average delay for all vehicle movements.

Delay Model: SIDRA Standard (Control Delay: Geometric Delay is included).

Queue Model: SIDRA queue estimation methods are used for Back of Queue and Queue at Start of Green.

Gap-Acceptance Capacity Formula: SIDRA Standard (Akçelik M3D).

HV (%) values are calculated for All Movement Classes of All Heavy Vehicle Model Designation.

Arrival Flows used in performance calculations are adjusted to include any Initial Queued Demand and Upstream Capacity Constraint effects.

\* Critical Movement (Signal Timing)

| Pedestrian Movement Performance |          |           |             |                  |                       |        |           |                |             |              |             |
|---------------------------------|----------|-----------|-------------|------------------|-----------------------|--------|-----------|----------------|-------------|--------------|-------------|
| Mov ID                          | Crossing | Dem. Flow | Aver. Delay | Level of Service | AVERAGE BACK OF QUEUE |        | Prop. Que | Eff. Stop Rate | Travel Time | Travel Dist. | Aver. Speed |
|                                 |          | ped/h     | sec         |                  | [ Ped                 | Dist ] |           |                | sec         | m            | m/sec       |
|                                 |          |           |             |                  | ped                   | m      |           |                |             |              |             |
| South: Alexander St (S)         |          |           |             |                  |                       |        |           |                |             |              |             |
| P1                              | Full     | 94        | 54.7        | LOS E            | 0.3                   | 0.3    | 0.92      | 0.92           | 71.3        | 20.0         | 0.28        |
| East: Falcon St (E)             |          |           |             |                  |                       |        |           |                |             |              |             |
| P2                              | Full     | 61        | 54.6        | LOS E            | 0.2                   | 0.2    | 0.92      | 0.92           | 71.3        | 20.0         | 0.28        |
| North: Alexander St (N)         |          |           |             |                  |                       |        |           |                |             |              |             |
| P3                              | Full     | 100       | 54.7        | LOS E            | 0.3                   | 0.3    | 0.92      | 0.92           | 71.4        | 20.0         | 0.28        |
| West: Falcon St (W)             |          |           |             |                  |                       |        |           |                |             |              |             |
| P4                              | Full     | 161       | 54.8        | LOS E            | 0.5                   | 0.5    | 0.92      | 0.92           | 71.5        | 20.0         | 0.28        |
| All Pedestrians                 |          | 416       | 54.7        | LOS E            | 0.5                   | 0.5    | 0.92      | 0.92           | 71.4        | 20.0         | 0.28        |

Level of Service (LOS) Method: SIDRA Pedestrian LOS Method (Based on Average Delay)

Pedestrian movement LOS values are based on average delay per pedestrian movement.

Intersection LOS value for Pedestrians is based on average delay for all pedestrian movements.

**SIDRA INTERSECTION 9.1 | Copyright © 2000-2022 Akcelik and Associates Pty Ltd | sidrasolutions.com**

Organisation: AECOM AUSTRALIA PTY LTD | Licence: NETWORK / Enterprise Level 1 | Processed: Monday, 17 July 2023 1:41:44 PM

Project: C:\Users\YeungMA\AECOM\ANZ-NAC-Sydney Metro-Sydney Metro C&SW Operational Monitoring - General\400\_Technical\432\_Traffic Analysis\SIDRA Modelling\01 Models (Geometry Only)\Block 1\Rev1\_Review\02 SM C&SW\_CST (Block 1)\_PS.sip9

# MOVEMENT SUMMARY

Site: VIC01 [VIC01 Pacific Hwy / Berry St (Site Folder: Block 1 Model - 2023 AM Peak)]

Output produced by SIDRA INTERSECTION Version: 9.1.1.200

Network: VIC-N1 [VIC Network 1 (Network Folder: Block 1 Network - 2023 AM Peak)]

TCS 1206

Site Category: (None)

Signals - EQUISAT (Fixed-Time/SCATS) Coordinated Cycle Time = 100 seconds (Network Site User-Given Phase Times)

| Vehicle Movement Performance |      |           |              |              |               |              |           |             |                  |                   |            |           |                |                     |             |
|------------------------------|------|-----------|--------------|--------------|---------------|--------------|-----------|-------------|------------------|-------------------|------------|-----------|----------------|---------------------|-------------|
| Mov ID                       | Turn | Mov Class | Demand Flows |              | Arrival Flows |              | Deg. Satn | Aver. Delay | Level of Service | 95% Back Of Queue |            | Prop. Que | Eff. Stop Rate | Aver. No. of Cycles | Aver. Speed |
|                              |      |           | [ Total HV ] | [ Total HV ] | [ Total HV ]  | [ Total HV ] |           |             |                  | [ Veh. veh        | [ Dist ] m |           |                |                     |             |
|                              |      |           | veh/h        | %            | veh/h         | %            | v/c       | sec         |                  |                   |            |           |                |                     | km/h        |
| SouthEast: Pacific Hwy (SE)  |      |           |              |              |               |              |           |             |                  |                   |            |           |                |                     |             |
| 1                            | L2   | All MCs   | 89           | 1.2          | 89            | 1.2          | 0.211     | 7.0         | LOS A            | 3.0               | 21.8       | 0.25      | 0.34           | 0.25                | 38.5        |
| 2                            | T1   | All MCs   | 700          | 8.3          | 700           | 8.3          | 0.211     | 3.8         | LOS A            | 3.3               | 24.4       | 0.27      | 0.26           | 0.27                | 50.1        |
| 23b                          | R3   | All MCs   | 134          | 4.7          | 134           | 4.7          | *0.663    | 31.5        | LOS C            | 4.0               | 28.8       | 0.98      | 0.81           | 1.04                | 18.7        |
| Approach                     |      |           | 923          | 7.1          | 923           | 7.1          | 0.663     | 8.1         | LOS A            | 4.0               | 28.8       | 0.37      | 0.35           | 0.38                | 42.4        |
| NorthWest: Pacific Hwy (NW)  |      |           |              |              |               |              |           |             |                  |                   |            |           |                |                     |             |
| 27a                          | L1   | All MCs   | 554          | 9.9          | 554           | 9.9          | 0.210     | 8.7         | LOS A            | 3.8               | 28.7       | 0.31      | 0.66           | 0.31                | 33.4        |
| 8                            | T1   | All MCs   | 404          | 5.2          | 404           | 5.2          | *0.519    | 16.3        | LOS B            | 11.9              | 86.9       | 0.79      | 0.69           | 0.79                | 23.9        |
| Approach                     |      |           | 958          | 7.9          | 958           | 7.9          | 0.519     | 11.9        | LOS A            | 11.9              | 86.9       | 0.51      | 0.67           | 0.51                | 28.6        |
| SouthWest: Berry St (SW)     |      |           |              |              |               |              |           |             |                  |                   |            |           |                |                     |             |
| 10                           | L2   | All MCs   | 40           | 2.6          | 40            | 2.6          | 0.066     | 4.4         | LOS A            | 0.3               | 1.9        | 0.15      | 0.50           | 0.15                | 37.4        |
| Approach                     |      |           | 40           | 2.6          | 40            | 2.6          | 0.066     | 4.4         | LOS A            | 0.3               | 1.9        | 0.15      | 0.50           | 0.15                | 37.4        |
| All Vehicles                 |      |           | 1921         | 7.4          | 1921          | 7.4          | 0.663     | 9.9         | LOS A            | 11.9              | 86.9       | 0.43      | 0.51           | 0.44                | 36.6        |

Site Level of Service (LOS) Method: Delay (RTA NSW). Site LOS Method is specified in the Network Data dialog (Override Site Data tab).

Vehicle movement LOS values are based on average delay per movement.

Intersection and Approach LOS values are based on average delay for all vehicle movements.

Delay Model: SIDRA Standard (Control Delay: Geometric Delay is included).

Queue Model: SIDRA queue estimation methods are used for Back of Queue and Queue at Start of Green.

Gap-Acceptance Capacity Formula: SIDRA Standard (Akçelik M3D).

HV (%) values are calculated for All Movement Classes of All Heavy Vehicle Model Designation.

Arrival Flows used in performance calculations are adjusted to include any Initial Queued Demand and Upstream Capacity Constraint effects.

\* Critical Movement (Signal Timing)

| Pedestrian Movement Performance |                 |                    |                    |                  |  |     |           |                |                    |                   |                      |
|---------------------------------|-----------------|--------------------|--------------------|------------------|--|-----|-----------|----------------|--------------------|-------------------|----------------------|
| Mov ID                          | Crossing        | Dem. Flow<br>ped/h | Aver. Delay<br>sec | Level of Service | AVERAGE BACK OF QUEUE<br>[ Ped Dist ]<br>ped m |     | Prop. Que | Eff. Stop Rate | Travel Time<br>sec | Travel Dist.<br>m | Aver. Speed<br>m/sec |
| SouthEast: Pacific Hwy (SE)     |                 |                    |                    |                  |  |     |           |                |                    |                   |                      |
| P1                              | Full            | 228                | 39.1               | LOS D            | 0.6  | 0.6 | 0.89      | 0.89           | 55.8               | 20.0              | 0.36                 |
| East: Berry St (E)              |                 |                    |                    |                  |  |     |           |                |                    |                   |                      |
| P2                              | Full            | 327                | 42.0               | LOS E            | 0.9  | 0.9 | 0.92      | 0.92           | 208.6              | 200.0             | 0.96                 |
| NorthWest: Pacific Hwy (NW)     |                 |                    |                    |                  |  |     |           |                |                    |                   |                      |
| P3B                             | Slip/<br>Bypass | 327                | 42.0               | LOS E            | 0.9  | 0.9 | 0.92      | 0.92           | 58.6               | 20.0              | 0.34                 |
| SouthWest: Berry St (SW)        |                 |                    |                    |                  |  |     |           |                |                    |                   |                      |
| P4                              | Full            | 260                | 22.8               | LOS C            | 0.5  | 0.5 | 0.89      | 0.89           | 39.5               | 20.0              | 0.51                 |
| All Pedestrians                 |                 | 1143               | 37.1               | LOS D            | 0.9  | 0.9 | 0.91      | 0.91           | 96.7               | 71.5              | 0.74                 |

Level of Service (LOS) Method: SIDRA Pedestrian LOS Method (Based on Average Delay)

Pedestrian movement LOS values are based on average delay per pedestrian movement.

Intersection LOS value for Pedestrians is based on average delay for all pedestrian movements.

---

**SIDRA INTERSECTION 9.1 | Copyright © 2000-2022 Akcelik and Associates Pty Ltd | sidrasolutions.com**

Organisation: AECOM AUSTRALIA PTY LTD | Licence: NETWORK / Enterprise Level 1 | Processed: Friday, 14 July 2023 9:58:10 AM

Project: C:\Users\YeungM\AECOM\ANZ-NAC-Sydney Metro-Sydney Metro C&SW Operational Monitoring - General\400\_Technical\432\_Traffic Analysis\SIDRA Modelling\01 Models (Geometry Only)\Block 1\Rev1\Review\03 SM C&SW\_VIC (Block 1)\_PS.sip9

# MOVEMENT SUMMARY

Site: VIC02 [VIC02 Miller St / Berry St (Site Folder: Block 1 Model - 2023 AM Peak)]

Output produced by SIDRA INTERSECTION Version: 9.1.1.200

Network: VIC-N1 [VIC Network 1 (Network Folder: Block 1 Network - 2023 AM Peak)]

TCS 874

Site Category: (None)

Signals - EQUISAT (Fixed-Time/SCATS) Coordinated Cycle Time = 100 seconds (Network Site User-Given Phase Times)

| Vehicle Movement Performance |      |           |                       |      |                       |      |           |             |                  |                   |               |           |                |                     |             |
|------------------------------|------|-----------|-----------------------|------|-----------------------|------|-----------|-------------|------------------|-------------------|---------------|-----------|----------------|---------------------|-------------|
| Mov ID                       | Turn | Mov Class | Demand Flows          |      | Arrival Flows         |      | Deg. Satn | Aver. Delay | Level of Service | 95% Back Of Queue |               | Prop. Que | Eff. Stop Rate | Aver. No. of Cycles | Aver. Speed |
|                              |      |           | [ Total HV ]<br>veh/h | %    | [ Total HV ]<br>veh/h | %    |           |             |                  | [ Veh. veh        | [ Dist ]<br>m |           |                |                     |             |
| South: Miller St (S)         |      |           |                       |      |                       |      |           |             |                  |                   |               |           |                |                     |             |
| 2                            | T1   | All MCs   | 225                   | 11.2 | 225                   | 11.2 | 0.242     | 15.8        | LOS B            | 6.7               | 51.1          | 0.65      | 0.54           | 0.65                | 21.3        |
| 3                            | R2   | All MCs   | 246                   | 3.0  | 246                   | 3.0  | *0.851    | 53.4        | LOS D            | 11.4              | 81.7          | 1.00      | 1.12           | 1.21                | 14.8        |
| Approach                     |      |           | 472                   | 6.9  | 472                   | 6.9  | 0.851     | 35.5        | LOS C            | 11.4              | 81.7          | 0.83      | 0.84           | 0.94                | 16.5        |
| North: Miller St (N)         |      |           |                       |      |                       |      |           |             |                  |                   |               |           |                |                     |             |
| 7                            | L2   | All MCs   | 246                   | 5.1  | 246                   | 5.1  | *0.778    | 49.9        | LOS D            | 12.4              | 90.8          | 1.00      | 0.92           | 1.14                | 15.9        |
| 8                            | T1   | All MCs   | 240                   | 15.4 | 240                   | 15.4 | 0.473     | 31.1        | LOS C            | 9.7               | 76.5          | 0.87      | 0.73           | 0.87                | 15.3        |
| Approach                     |      |           | 486                   | 10.2 | 486                   | 10.2 | 0.778     | 40.6        | LOS C            | 12.4              | 90.8          | 0.93      | 0.83           | 1.00                | 15.7        |
| West: Berry St (W)           |      |           |                       |      |                       |      |           |             |                  |                   |               |           |                |                     |             |
| 10                           | L2   | All MCs   | 79                    | 13.3 | 79                    | 13.3 | *0.439    | 38.1        | LOS C            | 8.0               | 59.1          | 0.80      | 0.70           | 0.80                | 11.3        |
| 11                           | T1   | All MCs   | 614                   | 2.9  | 614                   | 2.9  | 0.439     | 21.7        | LOS B            | 9.2               | 66.2          | 0.72      | 0.63           | 0.72                | 21.0        |
| 12                           | R2   | All MCs   | 46                    | 68.2 | 46                    | 68.2 | 0.439     | 31.7        | LOS C            | 7.8               | 62.1          | 0.72      | 0.64           | 0.72                | 13.2        |
| Approach                     |      |           | 739                   | 8.1  | 739                   | 8.1  | 0.439     | 24.1        | LOS B            | 9.2               | 66.2          | 0.73      | 0.64           | 0.73                | 19.8        |
| All Vehicles                 |      |           | 1697                  | 8.4  | 1697                  | 8.4  | 0.851     | 32.0        | LOS C            | 12.4              | 90.8          | 0.82      | 0.75           | 0.87                | 17.4        |

Site Level of Service (LOS) Method: Delay (RTA NSW). Site LOS Method is specified in the Network Data dialog (Override Site Data tab).

Vehicle movement LOS values are based on average delay per movement.

Intersection and Approach LOS values are based on average delay for all vehicle movements.

Delay Model: SIDRA Standard (Control Delay: Geometric Delay is included).

Queue Model: SIDRA queue estimation methods are used for Back of Queue and Queue at Start of Green.

Gap-Acceptance Capacity Formula: SIDRA Standard (Akçelik M3D).

HV (%) values are calculated for All Movement Classes of All Heavy Vehicle Model Designation.

Arrival Flows used in performance calculations are adjusted to include any Initial Queued Demand and Upstream Capacity Constraint effects.

\* Critical Movement (Signal Timing)

| Pedestrian Movement Performance |          |           |             |                  |                       |        |           |                |             |              |             |
|---------------------------------|----------|-----------|-------------|------------------|-----------------------|--------|-----------|----------------|-------------|--------------|-------------|
| Mov ID                          | Crossing | Dem. Flow | Aver. Delay | Level of Service | AVERAGE BACK OF QUEUE |        | Prop. Que | Eff. Stop Rate | Travel Time | Travel Dist. | Aver. Speed |
|                                 |          | ped/h     | sec         |                  | [ Ped                 | Dist ] |           |                | sec         | m            | m/sec       |
|                                 |          |           |             |                  | ped                   | m      |           |                |             |              |             |
| South: Miller St (S)            |          |           |             |                  |                       |        |           |                |             |              |             |
| P1                              | Full     | 318       | 42.0        | LOS E            | 0.8                   | 0.8    | 0.92      | 0.92           | 58.6        | 20.0         | 0.34        |
| East: Berry St (E)              |          |           |             |                  |                       |        |           |                |             |              |             |
| P2                              | Full     | 455       | 43.1        | LOS E            | 1.2                   | 1.2    | 0.94      | 0.94           | 59.8        | 20.0         | 0.33        |
| North: Miller St (N)            |          |           |             |                  |                       |        |           |                |             |              |             |
| P3                              | Full     | 317       | 40.1        | LOS E            | 0.8                   | 0.8    | 0.90      | 0.90           | 56.8        | 20.0         | 0.35        |
| West: Berry St (W)              |          |           |             |                  |                       |        |           |                |             |              |             |
| P4                              | Full     | 700       | 43.6        | LOS E            | 1.9                   | 1.9    | 0.95      | 0.95           | 60.3        | 20.0         | 0.33        |
| All Pedestrians                 |          | 1789      | 42.6        | LOS E            | 1.9                   | 1.9    | 0.93      | 0.93           | 59.2        | 20.0         | 0.34        |

Level of Service (LOS) Method: SIDRA Pedestrian LOS Method (Based on Average Delay)

Pedestrian movement LOS values are based on average delay per pedestrian movement.

Intersection LOS value for Pedestrians is based on average delay for all pedestrian movements.

**SIDRA INTERSECTION 9.1 | Copyright © 2000-2022 Akcelik and Associates Pty Ltd | sidrasolutions.com**

Organisation: AECOM AUSTRALIA PTY LTD | Licence: NETWORK / Enterprise Level 1 | Processed: Friday, 14 July 2023 9:58:10 AM

Project: C:\Users\YeungMA\AECOM\ANZ-NAC-Sydney Metro-Sydney Metro C&SW Operational Monitoring - General\400\_Technical\432\_Traffic Analysis\SIDRA Modelling\01 Models (Geometry Only)\Block 1\Rev1\_Review\03 SM C&SW\_VIC (Block 1)\_PS.sip9

# MOVEMENT SUMMARY

Site: VIC03 [VIC03 Miller St / McLaren St (Site Folder: Block 1 Model - 2023 AM Peak)]

Output produced by SIDRA INTERSECTION Version: 9.1.1.200

Network: VIC-N1 [VIC Network 1 (Network Folder: Block 1 Network - 2023 AM Peak)]

TCS 1156

Site Category: (None)

Signals - EQUISAT (Fixed-Time/SCATS) Isolated Cycle Time = 65 seconds (Site User-Given Phase Times)

| Vehicle Movement Performance |      |           |                       |      |                       |      |           |             |                  |                   |               |           |                |                     |                  |
|------------------------------|------|-----------|-----------------------|------|-----------------------|------|-----------|-------------|------------------|-------------------|---------------|-----------|----------------|---------------------|------------------|
| Mov ID                       | Turn | Mov Class | Demand Flows          |      | Arrival Flows         |      | Deg. Satn | Aver. Delay | Level of Service | 95% Back Of Queue |               | Prop. Que | Eff. Stop Rate | Aver. No. of Cycles | Aver. Speed km/h |
|                              |      |           | [ Total HV ]<br>veh/h | %    | [ Total HV ]<br>veh/h | %    |           |             |                  | [ Veh. veh        | [ Dist ]<br>m |           |                |                     |                  |
| South: Miller St (S)         |      |           |                       |      |                       |      |           |             |                  |                   |               |           |                |                     |                  |
| 1                            | L2   | All MCs   | 69                    | 4.5  | 69                    | 4.5  | 0.075     | 11.4        | LOS A            | 1.1               | 7.7           | 0.50      | 0.62           | 0.50                | 32.9             |
| 2                            | T1   | All MCs   | 194                   | 11.4 | 194                   | 11.4 | 0.298     | 11.3        | LOS A            | 4.4               | 34.3          | 0.66      | 0.57           | 0.66                | 32.4             |
| 3                            | R2   | All MCs   | 23                    | 40.9 | 23                    | 40.9 | 0.298     | 21.0        | LOS B            | 4.4               | 34.3          | 0.66      | 0.57           | 0.66                | 26.4             |
| Approach                     |      |           | 286                   | 12.1 | 286                   | 12.1 | 0.298     | 12.1        | LOS A            | 4.4               | 34.3          | 0.62      | 0.59           | 0.62                | 32.1             |
| East: McLaren St (E)         |      |           |                       |      |                       |      |           |             |                  |                   |               |           |                |                     |                  |
| 4                            | L2   | All MCs   | 80                    | 7.9  | 80                    | 7.9  | *0.759    | 42.8        | LOS D            | 2.9               | 21.7          | 1.00      | 0.91           | 1.36                | 11.4             |
| 5                            | T1   | All MCs   | 99                    | 3.2  | 99                    | 3.2  | 0.213     | 21.5        | LOS B            | 2.6               | 18.4          | 0.83      | 0.66           | 0.83                | 29.0             |
| Approach                     |      |           | 179                   | 5.3  | 179                   | 5.3  | 0.759     | 31.0        | LOS C            | 2.9               | 21.7          | 0.91      | 0.77           | 1.07                | 20.8             |
| North: Miller St (N)         |      |           |                       |      |                       |      |           |             |                  |                   |               |           |                |                     |                  |
| 7                            | L2   | All MCs   | 29                    | 7.1  | 29                    | 7.1  | 0.333     | 23.1        | LOS B            | 5.4               | 41.5          | 0.68      | 0.66           | 0.68                | 19.0             |
| 8                            | T1   | All MCs   | 383                   | 11.0 | 383                   | 11.0 | 0.333     | 13.1        | LOS A            | 5.4               | 41.5          | 0.69      | 0.67           | 0.69                | 25.7             |
| 9                            | R2   | All MCs   | 62                    | 6.8  | 62                    | 6.8  | *0.333    | 22.3        | LOS B            | 4.6               | 34.6          | 0.72      | 0.69           | 0.72                | 31.9             |
| Approach                     |      |           | 475                   | 10.2 | 475                   | 10.2 | 0.333     | 15.0        | LOS B            | 5.4               | 41.5          | 0.70      | 0.67           | 0.70                | 26.2             |
| West: McLaren St (W)         |      |           |                       |      |                       |      |           |             |                  |                   |               |           |                |                     |                  |
| 10                           | L2   | All MCs   | 49                    | 2.1  | 49                    | 2.1  | 0.093     | 23.2        | LOS B            | 1.2               | 8.2           | 0.76      | 0.70           | 0.76                | 28.4             |
| 11                           | T1   | All MCs   | 72                    | 14.7 | 72                    | 14.7 | 0.393     | 18.7        | LOS B            | 3.0               | 22.8          | 0.92      | 0.72           | 0.92                | 23.8             |
| 12                           | R2   | All MCs   | 34                    | 3.1  | 34                    | 3.1  | *0.393    | 39.0        | LOS C            | 3.0               | 22.8          | 0.92      | 0.72           | 0.92                | 20.8             |
| Approach                     |      |           | 155                   | 8.2  | 155                   | 8.2  | 0.393     | 24.5        | LOS B            | 3.0               | 22.8          | 0.87      | 0.72           | 0.87                | 24.9             |
| All Vehicles                 |      |           | 1095                  | 9.6  | 1095                  | 9.6  | 0.759     | 18.2        | LOS B            | 5.4               | 41.5          | 0.74      | 0.67           | 0.76                | 26.6             |

Site Level of Service (LOS) Method: Delay (RTA NSW). Site LOS Method is specified in the Network Data dialog (Override Site Data tab).

Vehicle movement LOS values are based on average delay per movement.

Intersection and Approach LOS values are based on average delay for all vehicle movements.

Delay Model: SIDRA Standard (Control Delay: Geometric Delay is included).

Queue Model: SIDRA queue estimation methods are used for Back of Queue and Queue at Start of Green.

Gap-Acceptance Capacity Formula: SIDRA Standard (Akçelik M3D).

HV (%) values are calculated for All Movement Classes of All Heavy Vehicle Model Designation.

Arrival Flows used in performance calculations are adjusted to include any Initial Queued Demand and Upstream Capacity Constraint effects.

\* Critical Movement (Signal Timing)



| Pedestrian Movement Performance |          |           |             |                  |                       |        |           |                |             |              |             |
|---------------------------------|----------|-----------|-------------|------------------|-----------------------|--------|-----------|----------------|-------------|--------------|-------------|
| Mov ID                          | Crossing | Dem. Flow | Aver. Delay | Level of Service | AVERAGE BACK OF QUEUE |        | Prop. Que | Eff. Stop Rate | Travel Time | Travel Dist. | Aver. Speed |
|                                 |          | ped/h     | sec         |                  | [ Ped                 | Dist ] |           |                | sec         | m            | m/sec       |
|                                 |          |           |             |                  | ped                   | m      |           |                |             |              |             |
| South: Miller St (S)            |          |           |             |                  |                       |        |           |                |             |              |             |
| P1                              | Full     | 305       | 21.9        | LOS C            | 0.5                   | 0.5    | 0.83      | 0.83           | 38.6        | 20.0         | 0.52        |
| East: McLaren St (E)            |          |           |             |                  |                       |        |           |                |             |              |             |
| P2                              | Full     | 244       | 23.5        | LOS C            | 0.4                   | 0.4    | 0.85      | 0.85           | 40.2        | 20.0         | 0.50        |
| North: Miller St (N)            |          |           |             |                  |                       |        |           |                |             |              |             |
| P3                              | Full     | 81        | 22.5        | LOS C            | 0.1                   | 0.1    | 0.83      | 0.83           | 39.2        | 20.0         | 0.51        |
| West: McLaren St (W)            |          |           |             |                  |                       |        |           |                |             |              |             |
| P4                              | Full     | 241       | 22.7        | LOS C            | 0.4                   | 0.4    | 0.84      | 0.84           | 39.3        | 20.0         | 0.51        |
| All Pedestrians                 |          | 872       | 22.6        | LOS C            | 0.5                   | 0.5    | 0.84      | 0.84           | 39.3        | 20.0         | 0.51        |

Level of Service (LOS) Method: SIDRA Pedestrian LOS Method (Based on Average Delay)  
 Pedestrian movement LOS values are based on average delay per pedestrian movement.  
 Intersection LOS value for Pedestrians is based on average delay for all pedestrian movements.

# MOVEMENT SUMMARY

Site: VIC04 [VIC04 Pacific Hwy / Miller St (Site Folder: Block 1 Model - 2023 AM Peak)]

Output produced by SIDRA INTERSECTION Version: 9.1.1.200

Network: VIC-N1 [VIC Network 1 (Network Folder: Block 1 Network - 2023 AM Peak)]

TCS 630

Site Category: (None)

Signals - EQUISAT (Fixed-Time/SCATS) Coordinated Cycle Time = 100 seconds (Network Site User-Given Phase Times)

| Vehicle Movement Performance |      |           |              |              |               |              |           |             |                  |                   |            |           |                |                     |             |
|------------------------------|------|-----------|--------------|--------------|---------------|--------------|-----------|-------------|------------------|-------------------|------------|-----------|----------------|---------------------|-------------|
| Mov ID                       | Turn | Mov Class | Demand Flows |              | Arrival Flows |              | Deg. Satn | Aver. Delay | Level of Service | 95% Back Of Queue |            | Prop. Que | Eff. Stop Rate | Aver. No. of Cycles | Aver. Speed |
|                              |      |           | [ Total HV ] | [ Total HV ] | [ Total HV ]  | [ Total HV ] |           |             |                  | [ Veh. veh        | [ Dist ] m |           |                |                     |             |
|                              |      |           | veh/h        | %            | veh/h         | %            | v/c       | sec         |                  |                   |            |           |                |                     | km/h        |
| South: Miller St (S)         |      |           |              |              |               |              |           |             |                  |                   |            |           |                |                     |             |
| 1                            | L2   | All MCs   | 7            | 14.3         | 7             | 14.3         | 0.187     | 17.2        | LOS B            | 3.6               | 30.9       | 0.63      | 0.65           | 0.63                | 27.3        |
| 1a                           | L1   | All MCs   | 117          | 26.1         | 117           | 26.1         | 0.187     | 20.2        | LOS B            | 3.6               | 30.9       | 0.63      | 0.65           | 0.63                | 19.2        |
| 2                            | T1   | All MCs   | 171          | 13.0         | 171           | 13.0         | 0.644     | 38.9        | LOS C            | 9.7               | 75.6       | 0.97      | 0.82           | 0.98                | 12.7        |
| 3b                           | R3   | All MCs   | 40           | 13.2         | 40            | 13.2         | *0.644    | 50.3        | LOS D            | 9.7               | 75.6       | 0.97      | 0.82           | 0.98                | 20.3        |
| Approach                     |      |           | 335          | 17.6         | 335           | 17.6         | 0.644     | 33.3        | LOS C            | 9.7               | 75.6       | 0.84      | 0.76           | 0.85                | 16.0        |
| SouthEast: Pacific Hwy (SE)  |      |           |              |              |               |              |           |             |                  |                   |            |           |                |                     |             |
| 21b                          | L3   | All MCs   | 139          | 5.3          | 139           | 5.3          | 0.408     | 10.1        | LOS A            | 6.4               | 46.1       | 0.69      | 0.73           | 0.69                | 31.3        |
| 21a                          | L1   | All MCs   | 54           | 0.0          | 54            | 0.0          | 0.408     | 33.5        | LOS C            | 6.4               | 46.1       | 0.69      | 0.73           | 0.69                | 32.8        |
| 22                           | T1   | All MCs   | 636          | 4.6          | 636           | 4.6          | 0.408     | 24.9        | LOS B            | 10.3              | 75.1       | 0.77      | 0.67           | 0.77                | 22.1        |
| 23a                          | R1   | All MCs   | 302          | 3.8          | 302           | 3.8          | *0.747    | 44.1        | LOS D            | 12.8              | 92.3       | 0.99      | 0.96           | 1.07                | 14.7        |
| Approach                     |      |           | 1131         | 4.3          | 1131          | 4.3          | 0.747     | 28.6        | LOS C            | 12.8              | 92.3       | 0.82      | 0.76           | 0.84                | 21.5        |
| North: Miller St (N)         |      |           |              |              |               |              |           |             |                  |                   |            |           |                |                     |             |
| 7a                           | L1   | All MCs   | 91           | 37.2         | 91            | 37.2         | 0.118     | 7.3         | LOS A            | 1.0               | 9.0        | 0.24      | 0.46           | 0.24                | 36.9        |
| 8                            | T1   | All MCs   | 161          | 18.3         | 161           | 18.3         | 0.313     | 12.4        | LOS A            | 2.2               | 17.5       | 0.38      | 0.34           | 0.38                | 29.2        |
| 9                            | R2   | All MCs   | 12           | 0.0          | 12            | 0.0          | 0.313     | 18.6        | LOS B            | 1.3               | 10.5       | 0.38      | 0.42           | 0.38                | 29.5        |
| 9b                           | R3   | All MCs   | 19           | 16.7         | 19            | 16.7         | 0.313     | 19.0        | LOS B            | 1.3               | 10.5       | 0.38      | 0.42           | 0.38                | 22.1        |
| Approach                     |      |           | 282          | 23.5         | 282           | 23.5         | 0.313     | 11.4        | LOS A            | 2.2               | 17.5       | 0.34      | 0.39           | 0.34                | 31.1        |
| NorthWest: Pacific Hwy (NW)  |      |           |              |              |               |              |           |             |                  |                   |            |           |                |                     |             |
| 28                           | T1   | All MCs   | 245          | 6.9          | 245           | 6.9          | 0.240     | 25.8        | LOS B            | 4.1               | 30.5       | 0.72      | 0.58           | 0.72                | 30.7        |
| 29a                          | R1   | All MCs   | 168          | 1.3          | 168           | 1.3          | 0.446     | 25.7        | LOS B            | 5.1               | 35.9       | 0.64      | 0.68           | 0.64                | 27.2        |
| Approach                     |      |           | 414          | 4.6          | 414           | 4.6          | 0.446     | 25.7        | LOS B            | 5.1               | 35.9       | 0.69      | 0.62           | 0.69                | 29.2        |
| All Vehicles                 |      |           | 2161         | 8.9          | 2161          | 8.9          | 0.747     | 26.5        | LOS B            | 12.8              | 92.3       | 0.73      | 0.68           | 0.75                | 23.3        |

Site Level of Service (LOS) Method: Delay (RTA NSW). Site LOS Method is specified in the Network Data dialog (Override Site Data tab).

Vehicle movement LOS values are based on average delay per movement.

Intersection and Approach LOS values are based on average delay for all vehicle movements.

Delay Model: SIDRA Standard (Control Delay: Geometric Delay is included).

Queue Model: SIDRA queue estimation methods are used for Back of Queue and Queue at Start of Green.

Gap-Acceptance Capacity Formula: SIDRA Standard (Akçelik M3D).

HV (%) values are calculated for All Movement Classes of All Heavy Vehicle Model Designation.

Arrival Flows used in performance calculations are adjusted to include any Initial Queued Demand and Upstream Capacity Constraint effects.

\* Critical Movement (Signal Timing)

| Pedestrian Movement Performance |          |           |             |                  |                       |        |           |                |             |              |             |
|---------------------------------|----------|-----------|-------------|------------------|-----------------------|--------|-----------|----------------|-------------|--------------|-------------|
| Mov ID                          | Crossing | Dem. Flow | Aver. Delay | Level of Service | AVERAGE BACK OF QUEUE |        | Prop. Que | Eff. Stop Rate | Travel Time | Travel Dist. | Aver. Speed |
|                                 |          | ped/h     | sec         |                  | [ Ped                 | Dist ] |           |                | sec         | m            | m/sec       |
|                                 |          |           |             |                  | ped                   | m      |           |                |             |              |             |
| South: Miller St (S)            |          |           |             |                  |                       |        |           |                |             |              |             |
| P1                              | Full     | 577       | 40.6        | LOS E            | 1.5                   | 1.5    | 0.91      | 0.91           | 57.2        | 20.0         | 0.35        |
| SouthEast: Pacific Hwy (SE)     |          |           |             |                  |                       |        |           |                |             |              |             |
| P5                              | Full     | 138       | 38.1        | LOS D            | 0.3                   | 0.3    | 0.88      | 0.88           | 54.7        | 20.0         | 0.37        |
| North: Miller St (N)            |          |           |             |                  |                       |        |           |                |             |              |             |
| P3                              | Full     | 1044      | 40.5        | LOS E            | 2.7                   | 2.7    | 0.92      | 0.92           | 57.1        | 20.0         | 0.35        |
| NorthWest: Pacific Hwy (NW)     |          |           |             |                  |                       |        |           |                |             |              |             |
| P7                              | Full     | 624       | 37.1        | LOS D            | 1.5                   | 1.5    | 0.87      | 0.87           | 53.8        | 20.0         | 0.37        |
| All Pedestrians                 |          | 2383      | 39.5        | LOS D            | 2.7                   | 2.7    | 0.90      | 0.90           | 56.1        | 20.0         | 0.36        |

Level of Service (LOS) Method: SIDRA Pedestrian LOS Method (Based on Average Delay)  
 Pedestrian movement LOS values are based on average delay per pedestrian movement.  
 Intersection LOS value for Pedestrians is based on average delay for all pedestrian movements.

# MOVEMENT SUMMARY

Site: VIC01 [VIC01 Pacific Hwy / Berry St (Site Folder: Block 1 Model - 2023 PM Peak )]

Output produced by SIDRA INTERSECTION Version: 9.1.1.200

Network: N101 [VIC Network 1 (Network Folder: Block 1 Network - 2023 PM Peak)]

TCS 1206

Site Category: (None)

Signals - EQUISAT (Fixed-Time/SCATS) Coordinated Cycle Time = 100 seconds (Network Site User-Given Phase Times)

| Vehicle Movement Performance |      |           |                       |     |                       |     |           |             |                  |                   |               |           |                |                     |             |
|------------------------------|------|-----------|-----------------------|-----|-----------------------|-----|-----------|-------------|------------------|-------------------|---------------|-----------|----------------|---------------------|-------------|
| Mov ID                       | Turn | Mov Class | Demand Flows          |     | Arrival Flows         |     | Deg. Satn | Aver. Delay | Level of Service | 95% Back Of Queue |               | Prop. Que | Eff. Stop Rate | Aver. No. of Cycles | Aver. Speed |
|                              |      |           | [ Total HV ]<br>veh/h | %   | [ Total HV ]<br>veh/h | %   |           |             |                  | [ Veh. veh        | [ Dist ]<br>m |           |                |                     |             |
| SouthEast: Pacific Hwy (SE)  |      |           |                       |     |                       |     |           |             |                  |                   |               |           |                |                     |             |
| 1                            | L2   | All MCs   | 41                    | 0.0 | 41                    | 0.0 | 0.054     | 10.4        | LOS A            | 1.6               | 11.4          | 0.50      | 0.43           | 0.50                | 33.2        |
| 2                            | T1   | All MCs   | 741                   | 5.8 | 741                   | 5.8 | 0.268     | 2.0         | LOS A            | 4.1               | 30.0          | 0.16      | 0.14           | 0.16                | 54.9        |
| 23b                          | R3   | All MCs   | 260                   | 2.0 | 260                   | 2.0 | *0.859    | 47.0        | LOS D            | 9.4               | 66.8          | 1.00      | 0.95           | 1.22                | 13.9        |
| Approach                     |      |           | 1042                  | 4.6 | 1042                  | 4.6 | 0.859     | 13.6        | LOS A            | 9.4               | 66.8          | 0.38      | 0.35           | 0.44                | 36.4        |
| NorthWest: Pacific Hwy (NW)  |      |           |                       |     |                       |     |           |             |                  |                   |               |           |                |                     |             |
| 27a                          | L1   | All MCs   | 586                   | 7.0 | 586                   | 7.0 | 0.214     | 8.4         | LOS A            | 3.9               | 28.6          | 0.29      | 0.66           | 0.29                | 33.9        |
| 8                            | T1   | All MCs   | 297                   | 6.0 | 297                   | 6.0 | *0.414    | 16.3        | LOS B            | 8.6               | 63.3          | 0.77      | 0.65           | 0.77                | 23.9        |
| Approach                     |      |           | 883                   | 6.7 | 883                   | 6.7 | 0.414     | 11.0        | LOS A            | 8.6               | 63.3          | 0.45      | 0.65           | 0.45                | 29.7        |
| SouthWest: Berry St (SW)     |      |           |                       |     |                       |     |           |             |                  |                   |               |           |                |                     |             |
| 10                           | L2   | All MCs   | 33                    | 0.0 | 33                    | 0.0 | 0.056     | 4.5         | LOS A            | 0.2               | 1.6           | 0.15      | 0.51           | 0.15                | 37.5        |
| Approach                     |      |           | 33                    | 0.0 | 33                    | 0.0 | 0.056     | 4.5         | LOS A            | 0.2               | 1.6           | 0.15      | 0.51           | 0.15                | 37.5        |
| All Vehicles                 |      |           | 1958                  | 5.5 | 1958                  | 5.5 | 0.859     | 12.3        | LOS A            | 9.4               | 66.8          | 0.41      | 0.49           | 0.44                | 34.2        |

Site Level of Service (LOS) Method: Delay (RTA NSW). Site LOS Method is specified in the Network Data dialog (Override Site Data tab).

Vehicle movement LOS values are based on average delay per movement.

Intersection and Approach LOS values are based on average delay for all vehicle movements.

Delay Model: SIDRA Standard (Control Delay: Geometric Delay is included).

Queue Model: SIDRA queue estimation methods are used for Back of Queue and Queue at Start of Green.

Gap-Acceptance Capacity Formula: SIDRA Standard (Akçelik M3D).

HV (%) values are calculated for All Movement Classes of All Heavy Vehicle Model Designation.

Arrival Flows used in performance calculations are adjusted to include any Initial Queued Demand and Upstream Capacity Constraint effects.

\* Critical Movement (Signal Timing)

| Pedestrian Movement Performance |                 |           |             |                  |                       |        |           |                |             |              |             |
|---------------------------------|-----------------|-----------|-------------|------------------|-----------------------|--------|-----------|----------------|-------------|--------------|-------------|
| Mov ID                          | Crossing        | Dem. Flow | Aver. Delay | Level of Service | AVERAGE BACK OF QUEUE |        | Prop. Que | Eff. Stop Rate | Travel Time | Travel Dist. | Aver. Speed |
|                                 |                 | ped/h     | sec         |                  | [ Ped                 | Dist ] |           |                | sec         | m            | m/sec       |
|                                 |                 |           |             |                  | ped                   | m      |           |                |             |              |             |
| SouthEast: Pacific Hwy (SE)     |                 |           |             |                  |                       |        |           |                |             |              |             |
| P1                              | Full            | 223       | 39.1        | LOS D            | 0.6                   | 0.6    | 0.89      | 0.89           | 55.8        | 20.0         | 0.36        |
| East: Berry St (E)              |                 |           |             |                  |                       |        |           |                |             |              |             |
| P2                              | Full            | 207       | 41.8        | LOS E            | 0.5                   | 0.5    | 0.92      | 0.92           | 208.4       | 200.0        | 0.96        |
| NorthWest: Pacific Hwy (NW)     |                 |           |             |                  |                       |        |           |                |             |              |             |
| P3B                             | Slip/<br>Bypass | 207       | 41.8        | LOS E            | 0.5                   | 0.5    | 0.92      | 0.92           | 58.4        | 20.0         | 0.34        |
| SouthWest: Berry St (SW)        |                 |           |             |                  |                       |        |           |                |             |              |             |
| P4                              | Full            | 218       | 23.6        | LOS C            | 0.4                   | 0.4    | 0.89      | 0.89           | 40.2        | 20.0         | 0.50        |
| All Pedestrians                 |                 | 856       | 36.4        | LOS D            | 0.6                   | 0.6    | 0.90      | 0.90           | 89.4        | 63.6         | 0.71        |

Level of Service (LOS) Method: SIDRA Pedestrian LOS Method (Based on Average Delay)  
 Pedestrian movement LOS values are based on average delay per pedestrian movement.  
 Intersection LOS value for Pedestrians is based on average delay for all pedestrian movements.

# MOVEMENT SUMMARY

Site: VIC02 [VIC02 Miller St / Berry St (Site Folder: Block 1 Model - 2023 PM Peak )]

Output produced by SIDRA INTERSECTION Version: 9.1.1.200

Network: N101 [VIC Network 1 (Network Folder: Block 1 Network - 2023 PM Peak)]

TCS 874

Site Category: (None)

Signals - EQUISAT (Fixed-Time/SCATS) Coordinated Cycle Time = 100 seconds (Network Site User-Given Phase Times)

| Vehicle Movement Performance |      |           |                       |      |                       |      |           |             |                  |                   |               |           |                |                     |             |
|------------------------------|------|-----------|-----------------------|------|-----------------------|------|-----------|-------------|------------------|-------------------|---------------|-----------|----------------|---------------------|-------------|
| Mov ID                       | Turn | Mov Class | Demand Flows          |      | Arrival Flows         |      | Deg. Satn | Aver. Delay | Level of Service | 95% Back Of Queue |               | Prop. Que | Eff. Stop Rate | Aver. No. of Cycles | Aver. Speed |
|                              |      |           | [ Total HV ]<br>veh/h | %    | [ Total HV ]<br>veh/h | %    |           |             |                  | [ Veh. veh        | [ Dist ]<br>m |           |                |                     |             |
| South: Miller St (S)         |      |           |                       |      |                       |      |           |             |                  |                   |               |           |                |                     |             |
| 2                            | T1   | All MCs   | 266                   | 16.6 | 266                   | 16.6 | 0.295     | 15.4        | LOS B            | 7.9               | 63.1          | 0.65      | 0.55           | 0.65                | 21.5        |
| 3                            | R2   | All MCs   | 245                   | 6.0  | 245                   | 6.0  | *0.701    | 40.7        | LOS C            | 10.1              | 74.7          | 0.98      | 0.98           | 1.03                | 17.3        |
| Approach                     |      |           | 512                   | 11.5 | 512                   | 11.5 | 0.701     | 27.5        | LOS B            | 10.1              | 74.7          | 0.81      | 0.76           | 0.83                | 18.7        |
| North: Miller St (N)         |      |           |                       |      |                       |      |           |             |                  |                   |               |           |                |                     |             |
| 7                            | L2   | All MCs   | 212                   | 3.0  | 212                   | 3.0  | *0.619    | 44.5        | LOS D            | 9.7               | 69.8          | 0.97      | 0.82           | 0.97                | 17.0        |
| 8                            | T1   | All MCs   | 203                   | 10.4 | 203                   | 10.4 | 0.396     | 30.9        | LOS C            | 8.0               | 61.1          | 0.85      | 0.71           | 0.85                | 15.3        |
| Approach                     |      |           | 415                   | 6.6  | 415                   | 6.6  | 0.619     | 37.8        | LOS C            | 9.7               | 69.8          | 0.91      | 0.76           | 0.91                | 16.4        |
| West: Berry St (W)           |      |           |                       |      |                       |      |           |             |                  |                   |               |           |                |                     |             |
| 10                           | L2   | All MCs   | 117                   | 6.3  | 117                   | 6.3  | *0.537    | 40.9        | LOS C            | 10.4              | 75.2          | 0.87      | 0.76           | 0.87                | 10.2        |
| 11                           | T1   | All MCs   | 735                   | 2.1  | 735                   | 2.1  | 0.537     | 29.2        | LOS C            | 14.0              | 99.5          | 0.88      | 0.76           | 0.88                | 18.2        |
| 12                           | R2   | All MCs   | 51                    | 45.8 | 51                    | 45.8 | 0.537     | 42.4        | LOS C            | 12.3              | 93.3          | 0.89      | 0.77           | 0.89                | 10.5        |
| Approach                     |      |           | 902                   | 5.1  | 902                   | 5.1  | 0.537     | 31.5        | LOS C            | 14.0              | 99.5          | 0.88      | 0.76           | 0.88                | 17.0        |
| All Vehicles                 |      |           | 1828                  | 7.3  | 1828                  | 7.3  | 0.701     | 31.8        | LOS C            | 14.0              | 99.5          | 0.87      | 0.76           | 0.87                | 17.3        |

Site Level of Service (LOS) Method: Delay (RTA NSW). Site LOS Method is specified in the Network Data dialog (Override Site Data tab).

Vehicle movement LOS values are based on average delay per movement.

Intersection and Approach LOS values are based on average delay for all vehicle movements.

Delay Model: SIDRA Standard (Control Delay: Geometric Delay is included).

Queue Model: SIDRA queue estimation methods are used for Back of Queue and Queue at Start of Green.

Gap-Acceptance Capacity Formula: SIDRA Standard (Akçelik M3D).

HV (%) values are calculated for All Movement Classes of All Heavy Vehicle Model Designation.

Arrival Flows used in performance calculations are adjusted to include any Initial Queued Demand and Upstream Capacity Constraint effects.

\* Critical Movement (Signal Timing)

| Pedestrian Movement Performance |          |           |             |                  |                       |        |           |                |             |              |             |
|---------------------------------|----------|-----------|-------------|------------------|-----------------------|--------|-----------|----------------|-------------|--------------|-------------|
| Mov ID                          | Crossing | Dem. Flow | Aver. Delay | Level of Service | AVERAGE BACK OF QUEUE |        | Prop. Que | Eff. Stop Rate | Travel Time | Travel Dist. | Aver. Speed |
|                                 |          | ped/h     | sec         |                  | [ Ped                 | Dist ] |           |                | sec         | m            | m/sec       |
|                                 |          |           |             |                  | ped                   | m      |           |                |             |              |             |
| South: Miller St (S)            |          |           |             |                  |                       |        |           |                |             |              |             |
| P1                              | Full     | 218       | 41.8        | LOS E            | 0.6                   | 0.6    | 0.92      | 0.92           | 58.5        | 20.0         | 0.34        |
| East: Berry St (E)              |          |           |             |                  |                       |        |           |                |             |              |             |
| P2                              | Full     | 188       | 42.7        | LOS E            | 0.5                   | 0.5    | 0.93      | 0.93           | 59.3        | 20.0         | 0.34        |
| North: Miller St (N)            |          |           |             |                  |                       |        |           |                |             |              |             |
| P3                              | Full     | 264       | 40.0        | LOS E            | 0.7                   | 0.7    | 0.90      | 0.90           | 56.7        | 20.0         | 0.35        |
| West: Berry St (W)              |          |           |             |                  |                       |        |           |                |             |              |             |
| P4                              | Full     | 440       | 43.1        | LOS E            | 1.2                   | 1.2    | 0.94      | 0.94           | 59.8        | 20.0         | 0.33        |
| All Pedestrians                 |          | 1111      | 42.0        | LOS E            | 1.2                   | 1.2    | 0.92      | 0.92           | 58.7        | 20.0         | 0.34        |

Level of Service (LOS) Method: SIDRA Pedestrian LOS Method (Based on Average Delay)

Pedestrian movement LOS values are based on average delay per pedestrian movement.

Intersection LOS value for Pedestrians is based on average delay for all pedestrian movements.

**SIDRA INTERSECTION 9.1 | Copyright © 2000-2022 Akcelik and Associates Pty Ltd | sidrasolutions.com**

Organisation: AECOM AUSTRALIA PTY LTD | Licence: NETWORK / Enterprise Level 1 | Processed: Friday, 14 July 2023 9:58:13 AM

Project: C:\Users\YeungMA\AECOM\ANZ-NAC-Sydney Metro-Sydney Metro C&SW Operational Monitoring - General\400\_Technical\432\_Traffic Analysis\SIDRA Modelling\01 Models (Geometry Only)\Block 1\Rev1\_Review\03 SM C&SW\_VIC (Block 1)\_PS.sip9

# MOVEMENT SUMMARY

Site: VIC03 [VIC03 Miller St / McLaren St (Site Folder: Block 1 Model - 2023 PM Peak )]

Output produced by SIDRA INTERSECTION Version: 9.1.1.200

Network: N101 [VIC Network 1 (Network Folder: Block 1 Network - 2023 PM Peak)]

TCS 1156

Site Category: (None)

Signals - EQUISAT (Fixed-Time/SCATS) Isolated Cycle Time = 76 seconds (Site User-Given Phase Times)

| Vehicle Movement Performance |      |           |                       |      |                       |      |           |             |                  |                   |               |           |                |                     |                  |
|------------------------------|------|-----------|-----------------------|------|-----------------------|------|-----------|-------------|------------------|-------------------|---------------|-----------|----------------|---------------------|------------------|
| Mov ID                       | Turn | Mov Class | Demand Flows          |      | Arrival Flows         |      | Deg. Satn | Aver. Delay | Level of Service | 95% Back Of Queue |               | Prop. Que | Eff. Stop Rate | Aver. No. of Cycles | Aver. Speed km/h |
|                              |      |           | [ Total HV ]<br>veh/h | %    | [ Total HV ]<br>veh/h | %    |           |             |                  | [ Veh. veh        | [ Dist ]<br>m |           |                |                     |                  |
| South: Miller St (S)         |      |           |                       |      |                       |      |           |             |                  |                   |               |           |                |                     |                  |
| 1                            | L2   | All MCs   | 113                   | 0.9  | 113                   | 0.9  | 0.205     | 11.1        | LOS A            | 3.6               | 27.3          | 0.51      | 0.55           | 0.51                | 33.6             |
| 2                            | T1   | All MCs   | 237                   | 18.7 | 237                   | 18.7 | 0.205     | 8.5         | LOS A            | 3.6               | 27.3          | 0.52      | 0.50           | 0.52                | 34.3             |
| 3                            | R2   | All MCs   | 25                    | 33.3 | 25                    | 33.3 | 0.205     | 15.4        | LOS B            | 3.1               | 25.3          | 0.52      | 0.47           | 0.52                | 28.8             |
| Approach                     |      |           | 375                   | 14.3 | 375                   | 14.3 | 0.205     | 9.8         | LOS A            | 3.6               | 27.3          | 0.51      | 0.51           | 0.51                | 33.8             |
| East: McLaren St (E)         |      |           |                       |      |                       |      |           |             |                  |                   |               |           |                |                     |                  |
| 4                            | L2   | All MCs   | 55                    | 0.0  | 55                    | 0.0  | 0.747     | 50.7        | LOS D            | 2.3               | 16.3          | 1.00      | 0.86           | 1.35                | 10.1             |
| 5                            | T1   | All MCs   | 89                    | 1.2  | 89                    | 1.2  | *0.252    | 29.4        | LOS C            | 2.9               | 20.7          | 0.90      | 0.70           | 0.90                | 25.1             |
| Approach                     |      |           | 144                   | 0.7  | 144                   | 0.7  | 0.747     | 37.5        | LOS C            | 2.9               | 20.7          | 0.93      | 0.76           | 1.07                | 19.2             |
| North: Miller St (N)         |      |           |                       |      |                       |      |           |             |                  |                   |               |           |                |                     |                  |
| 7                            | L2   | All MCs   | 43                    | 0.0  | 43                    | 0.0  | 0.140     | 18.7        | LOS B            | 2.5               | 18.2          | 0.55      | 0.60           | 0.55                | 19.3             |
| 8                            | T1   | All MCs   | 285                   | 8.9  | 285                   | 8.9  | 0.339     | 11.4        | LOS A            | 5.8               | 43.4          | 0.60      | 0.63           | 0.60                | 27.1             |
| 9                            | R2   | All MCs   | 68                    | 7.7  | 68                    | 7.7  | *0.339    | 17.9        | LOS B            | 5.8               | 43.4          | 0.61      | 0.64           | 0.61                | 34.0             |
| Approach                     |      |           | 397                   | 7.7  | 397                   | 7.7  | 0.339     | 13.3        | LOS A            | 5.8               | 43.4          | 0.59      | 0.63           | 0.59                | 27.4             |
| West: McLaren St (W)         |      |           |                       |      |                       |      |           |             |                  |                   |               |           |                |                     |                  |
| 10                           | L2   | All MCs   | 58                    | 3.6  | 58                    | 3.6  | 0.164     | 32.5        | LOS C            | 1.8               | 13.2          | 0.87      | 0.73           | 0.87                | 24.3             |
| 11                           | T1   | All MCs   | 77                    | 0.0  | 77                    | 0.0  | 0.403     | 25.7        | LOS B            | 3.7               | 26.0          | 0.94      | 0.73           | 0.94                | 21.4             |
| 12                           | R2   | All MCs   | 34                    | 0.0  | 34                    | 0.0  | *0.403    | 42.4        | LOS C            | 3.7               | 26.0          | 0.94      | 0.73           | 0.94                | 18.5             |
| Approach                     |      |           | 168                   | 1.3  | 168                   | 1.3  | 0.403     | 31.4        | LOS C            | 3.7               | 26.0          | 0.91      | 0.73           | 0.91                | 22.0             |
| All Vehicles                 |      |           | 1084                  | 8.1  | 1084                  | 8.1  | 0.747     | 18.1        | LOS B            | 5.8               | 43.4          | 0.66      | 0.62           | 0.68                | 27.1             |

Site Level of Service (LOS) Method: Delay (RTA NSW). Site LOS Method is specified in the Network Data dialog (Override Site Data tab).

Vehicle movement LOS values are based on average delay per movement.

Intersection and Approach LOS values are based on average delay for all vehicle movements.

Delay Model: SIDRA Standard (Control Delay: Geometric Delay is included).

Queue Model: SIDRA queue estimation methods are used for Back of Queue and Queue at Start of Green.

Gap-Acceptance Capacity Formula: SIDRA Standard (Akçelik M3D).

HV (%) values are calculated for All Movement Classes of All Heavy Vehicle Model Designation.

Arrival Flows used in performance calculations are adjusted to include any Initial Queued Demand and Upstream Capacity Constraint effects.

\* Critical Movement (Signal Timing)



| Pedestrian Movement Performance |          |           |             |                  |                       |        |           |                |             |              |             |
|---------------------------------|----------|-----------|-------------|------------------|-----------------------|--------|-----------|----------------|-------------|--------------|-------------|
| Mov ID                          | Crossing | Dem. Flow | Aver. Delay | Level of Service | AVERAGE BACK OF QUEUE |        | Prop. Que | Eff. Stop Rate | Travel Time | Travel Dist. | Aver. Speed |
|                                 |          | ped/h     | sec         |                  | [ Ped                 | Dist ] |           |                | sec         | m            | m/sec       |
|                                 |          |           |             |                  | ped                   | m      |           |                |             |              |             |
| South: Miller St (S)            |          |           |             |                  |                       |        |           |                |             |              |             |
| P1                              | Full     | 159       | 27.1        | LOS C            | 0.3                   | 0.3    | 0.85      | 0.85           | 43.8        | 20.0         | 0.46        |
| East: McLaren St (E)            |          |           |             |                  |                       |        |           |                |             |              |             |
| P2                              | Full     | 282       | 29.0        | LOS C            | 0.5                   | 0.5    | 0.88      | 0.88           | 45.7        | 20.0         | 0.44        |
| North: Miller St (N)            |          |           |             |                  |                       |        |           |                |             |              |             |
| P3                              | Full     | 144       | 28.0        | LOS C            | 0.3                   | 0.3    | 0.86      | 0.86           | 44.6        | 20.0         | 0.45        |
| West: McLaren St (W)            |          |           |             |                  |                       |        |           |                |             |              |             |
| P4                              | Full     | 382       | 28.2        | LOS C            | 0.7                   | 0.7    | 0.87      | 0.87           | 44.9        | 20.0         | 0.45        |
| All Pedestrians                 |          | 967       | 28.2        | LOS C            | 0.7                   | 0.7    | 0.87      | 0.87           | 44.9        | 20.0         | 0.45        |

Level of Service (LOS) Method: SIDRA Pedestrian LOS Method (Based on Average Delay)

Pedestrian movement LOS values are based on average delay per pedestrian movement.

Intersection LOS value for Pedestrians is based on average delay for all pedestrian movements.

**SIDRA INTERSECTION 9.1 | Copyright © 2000-2022 Akcelik and Associates Pty Ltd | sidrasolutions.com**

Organisation: AECOM AUSTRALIA PTY LTD | Licence: NETWORK / Enterprise Level 1 | Processed: Friday, 14 July 2023 9:58:13 AM

Project: C:\Users\YeungMA\AECOM\ANZ-NAC-Sydney Metro-Sydney Metro C&SW Operational Monitoring - General\400\_Technical\432\_Traffic Analysis\SIDRA Modelling\01 Models (Geometry Only)\Block 1\Rev1\_Review\03 SM C&SW\_VIC (Block 1)\_PS.sip9

# MOVEMENT SUMMARY

Site: VIC04 [VIC04 Pacific Hwy / Miller St (Site Folder: Block 1 Model - 2023 PM Peak )]

Output produced by SIDRA INTERSECTION Version: 9.1.1.200

Network: N101 [VIC Network 1 (Network Folder: Block 1 Network - 2023 PM Peak)]

TCS 630

Site Category: (None)

Signals - EQUISAT (Fixed-Time/SCATS) Coordinated Cycle Time = 100 seconds (Network Site User-Given Phase Times)

| Vehicle Movement Performance |      |           |              |              |               |              |           |             |                  |                   |            |           |                |                     |             |
|------------------------------|------|-----------|--------------|--------------|---------------|--------------|-----------|-------------|------------------|-------------------|------------|-----------|----------------|---------------------|-------------|
| Mov ID                       | Turn | Mov Class | Demand Flows |              | Arrival Flows |              | Deg. Satn | Aver. Delay | Level of Service | 95% Back Of Queue |            | Prop. Que | Eff. Stop Rate | Aver. No. of Cycles | Aver. Speed |
|                              |      |           | [ Total HV ] | [ Total HV ] | [ Total HV ]  | [ Total HV ] |           |             |                  | [ Veh. veh        | [ Dist ] m |           |                |                     |             |
|                              |      |           | veh/h        | %            | veh/h         | %            | v/c       | sec         |                  |                   |            |           |                |                     | km/h        |
| South: Miller St (S)         |      |           |              |              |               |              |           |             |                  |                   |            |           |                |                     |             |
| 1                            | L2   | All MCs   | 8            | 0.0          | 8             | 0.0          | 0.166     | 18.7        | LOS B            | 3.2               | 27.0       | 0.65      | 0.65           | 0.65                | 26.9        |
| 1a                           | L1   | All MCs   | 100          | 24.2         | 100           | 24.2         | 0.166     | 21.3        | LOS B            | 3.2               | 27.0       | 0.65      | 0.65           | 0.65                | 18.7        |
| 2                            | T1   | All MCs   | 155          | 29.3         | 155           | 29.3         | 0.682     | 42.4        | LOS C            | 8.7               | 75.8       | 0.98      | 0.87           | 1.05                | 12.1        |
| 3b                           | R3   | All MCs   | 26           | 20.0         | 26            | 20.0         | *0.682    | 53.0        | LOS D            | 8.7               | 75.8       | 0.98      | 0.87           | 1.05                | 19.5        |
| Approach                     |      |           | 289          | 25.8         | 289           | 25.8         | 0.682     | 35.4        | LOS C            | 8.7               | 75.8       | 0.86      | 0.78           | 0.90                | 15.1        |
| SouthEast: Pacific Hwy (SE)  |      |           |              |              |               |              |           |             |                  |                   |            |           |                |                     |             |
| 21b                          | L3   | All MCs   | 245          | 3.9          | 245           | 3.9          | 0.562     | 10.2        | LOS A            | 10.2              | 73.2       | 0.73      | 0.76           | 0.73                | 31.9        |
| 21a                          | L1   | All MCs   | 40           | 0.0          | 40            | 0.0          | *0.562    | 35.6        | LOS C            | 10.2              | 73.2       | 0.73      | 0.76           | 0.73                | 33.3        |
| 22                           | T1   | All MCs   | 962          | 2.7          | 962           | 2.7          | 0.562     | 25.7        | LOS B            | 16.1              | 115.3      | 0.82      | 0.73           | 0.82                | 22.0        |
| 23a                          | R1   | All MCs   | 357          | 3.8          | 357           | 3.8          | *0.809    | 42.2        | LOS C            | 14.4              | 104.1      | 1.00      | 1.00           | 1.13                | 15.2        |
| Approach                     |      |           | 1604         | 3.1          | 1604          | 3.1          | 0.809     | 27.2        | LOS B            | 16.1              | 115.3      | 0.84      | 0.80           | 0.87                | 22.1        |
| North: Miller St (N)         |      |           |              |              |               |              |           |             |                  |                   |            |           |                |                     |             |
| 7a                           | L1   | All MCs   | 98           | 21.5         | 98            | 21.5         | 0.112     | 6.2         | LOS A            | 0.9               | 7.1        | 0.19      | 0.43           | 0.19                | 38.0        |
| 8                            | T1   | All MCs   | 140          | 15.0         | 140           | 15.0         | 0.274     | 15.6        | LOS B            | 1.9               | 15.3       | 0.44      | 0.37           | 0.44                | 27.5        |
| 9                            | R2   | All MCs   | 4            | 25.0         | 4             | 25.0         | 0.274     | 23.1        | LOS B            | 1.4               | 10.8       | 0.44      | 0.42           | 0.44                | 28.2        |
| 9b                           | R3   | All MCs   | 13           | 16.7         | 13            | 16.7         | 0.274     | 23.7        | LOS B            | 1.4               | 10.8       | 0.44      | 0.42           | 0.44                | 20.4        |
| Approach                     |      |           | 255          | 17.8         | 255           | 17.8         | 0.274     | 12.5        | LOS A            | 1.9               | 15.3       | 0.34      | 0.40           | 0.34                | 30.6        |
| NorthWest: Pacific Hwy (NW)  |      |           |              |              |               |              |           |             |                  |                   |            |           |                |                     |             |
| 28                           | T1   | All MCs   | 163          | 9.0          | 163           | 9.0          | 0.163     | 12.2        | LOS A            | 1.4               | 10.4       | 0.36      | 0.29           | 0.36                | 41.4        |
| 29a                          | R1   | All MCs   | 121          | 3.5          | 121           | 3.5          | 0.328     | 50.1        | LOS D            | 5.9               | 42.7       | 1.00      | 0.83           | 1.00                | 19.1        |
| Approach                     |      |           | 284          | 6.7          | 284           | 6.7          | 0.328     | 28.3        | LOS B            | 5.9               | 42.7       | 0.63      | 0.52           | 0.63                | 27.8        |
| All Vehicles                 |      |           | 2433         | 7.7          | 2433          | 7.7          | 0.809     | 26.8        | LOS B            | 16.1              | 115.3      | 0.77      | 0.72           | 0.79                | 22.8        |

Site Level of Service (LOS) Method: Delay (RTA NSW). Site LOS Method is specified in the Network Data dialog (Override Site Data tab).

Vehicle movement LOS values are based on average delay per movement.

Intersection and Approach LOS values are based on average delay for all vehicle movements.

Delay Model: SIDRA Standard (Control Delay: Geometric Delay is included).

Queue Model: SIDRA queue estimation methods are used for Back of Queue and Queue at Start of Green.

Gap-Acceptance Capacity Formula: SIDRA Standard (Akçelik M3D).

HV (%) values are calculated for All Movement Classes of All Heavy Vehicle Model Designation.

Arrival Flows used in performance calculations are adjusted to include any Initial Queued Demand and Upstream Capacity Constraint effects.

\* Critical Movement (Signal Timing)

| Pedestrian Movement Performance |          |           |             |                  |                       |        |           |                |             |              |             |
|---------------------------------|----------|-----------|-------------|------------------|-----------------------|--------|-----------|----------------|-------------|--------------|-------------|
| Mov ID                          | Crossing | Dem. Flow | Aver. Delay | Level of Service | AVERAGE BACK OF QUEUE |        | Prop. Que | Eff. Stop Rate | Travel Time | Travel Dist. | Aver. Speed |
|                                 |          | ped/h     | sec         |                  | [ Ped                 | Dist ] |           |                | sec         | m            | m/sec       |
|                                 |          |           |             |                  | ped                   | m      |           |                |             |              |             |
| South: Miller St (S)            |          |           |             |                  |                       |        |           |                |             |              |             |
| P1                              | Full     | 624       | 40.7        | LOS E            | 1.6                   | 1.6    | 0.91      | 0.91           | 57.3        | 20.0         | 0.35        |
| SouthEast: Pacific Hwy (SE)     |          |           |             |                  |                       |        |           |                |             |              |             |
| P5                              | Full     | 186       | 38.1        | LOS D            | 0.5                   | 0.5    | 0.88      | 0.88           | 54.8        | 20.0         | 0.36        |
| North: Miller St (N)            |          |           |             |                  |                       |        |           |                |             |              |             |
| P3                              | Full     | 1215      | 40.8        | LOS E            | 3.2                   | 3.2    | 0.93      | 0.93           | 57.5        | 20.0         | 0.35        |
| NorthWest: Pacific Hwy (NW)     |          |           |             |                  |                       |        |           |                |             |              |             |
| P7                              | Full     | 451       | 36.8        | LOS D            | 1.1                   | 1.1    | 0.87      | 0.87           | 53.5        | 20.0         | 0.37        |
| All Pedestrians                 |          | 2476      | 39.8        | LOS D            | 3.2                   | 3.2    | 0.91      | 0.91           | 56.5        | 20.0         | 0.35        |

Level of Service (LOS) Method: SIDRA Pedestrian LOS Method (Based on Average Delay)

Pedestrian movement LOS values are based on average delay per pedestrian movement.

Intersection LOS value for Pedestrians is based on average delay for all pedestrian movements.

**SIDRA INTERSECTION 9.1 | Copyright © 2000-2022 Akcelik and Associates Pty Ltd | sidrasolutions.com**

Organisation: AECOM AUSTRALIA PTY LTD | Licence: NETWORK / Enterprise Level 1 | Processed: Friday, 14 July 2023 9:58:13 AM

Project: C:\Users\YeungMAECOMANZ-NAC-Sydney Metro-Sydney Metro C&SW Operational Monitoring - General\400\_Technical\432\_Traffic Analysis\SIDRA Modelling\01 Models (Geometry Only)\Block 1\Rev1\_Review\03 SM C&SW\_VIC (Block 1)\_PS.sip9

# MOVEMENT SUMMARY

Site: VIC01 [VIC01 Pacific Hwy / Berry St (Site Folder: Block 1 Model - 2023 Weekend Peak )]

Output produced by SIDRA INTERSECTION Version: 9.1.1.200

Network: N101 [VIC Network 1 (Network Folder: Block 1 Network - 2023 Weekend Peak)]

TCS 1206

Site Category: (None)

Signals - EQUISAT (Fixed-Time/SCATS) Coordinated Cycle Time = 90 seconds (Network Site User-Given Phase Times)

| Vehicle Movement Performance |      |           |                       |     |                       |     |           |             |                  |                   |               |           |                |                     |             |
|------------------------------|------|-----------|-----------------------|-----|-----------------------|-----|-----------|-------------|------------------|-------------------|---------------|-----------|----------------|---------------------|-------------|
| Mov ID                       | Turn | Mov Class | Demand Flows          |     | Arrival Flows         |     | Deg. Satn | Aver. Delay | Level of Service | 95% Back Of Queue |               | Prop. Que | Eff. Stop Rate | Aver. No. of Cycles | Aver. Speed |
|                              |      |           | [ Total HV ]<br>veh/h | %   | [ Total HV ]<br>veh/h | %   |           |             |                  | [ Veh. veh        | [ Dist ]<br>m |           |                |                     |             |
| SouthEast: Pacific Hwy (SE)  |      |           |                       |     |                       |     |           |             |                  |                   |               |           |                |                     |             |
| 1                            | L2   | All MCs   | 19                    | 0.0 | 19                    | 0.0 | 0.048     | 4.3         | LOS A            | 0.2               | 1.7           | 0.08      | 0.18           | 0.08                | 42.6        |
| 2                            | T1   | All MCs   | 717                   | 2.8 | 717                   | 2.8 | 0.229     | 0.8         | LOS A            | 1.4               | 10.1          | 0.08      | 0.08           | 0.08                | 57.8        |
| 23b                          | R3   | All MCs   | 106                   | 0.0 | 106                   | 0.0 | *0.491    | 51.7        | LOS D            | 4.8               | 33.5          | 1.00      | 0.81           | 1.00                | 12.9        |
| Approach                     |      |           | 842                   | 2.4 | 842                   | 2.4 | 0.491     | 7.3         | LOS A            | 4.8               | 33.5          | 0.20      | 0.17           | 0.20                | 45.2        |
| NorthWest: Pacific Hwy (NW)  |      |           |                       |     |                       |     |           |             |                  |                   |               |           |                |                     |             |
| 27a                          | L1   | All MCs   | 536                   | 3.7 | 536                   | 3.7 | 0.170     | 6.2         | LOS A            | 1.9               | 14.1          | 0.18      | 0.62           | 0.18                | 38.3        |
| 8                            | T1   | All MCs   | 323                   | 1.0 | 323                   | 1.0 | 0.295     | 10.8        | LOS A            | 7.3               | 51.5          | 0.56      | 0.48           | 0.56                | 30.0        |
| Approach                     |      |           | 859                   | 2.7 | 859                   | 2.7 | 0.295     | 7.9         | LOS A            | 7.3               | 51.5          | 0.32      | 0.57           | 0.32                | 34.7        |
| SouthWest: Berry St (SW)     |      |           |                       |     |                       |     |           |             |                  |                   |               |           |                |                     |             |
| 10                           | L2   | All MCs   | 25                    | 0.0 | 25                    | 0.0 | 0.032     | 4.9         | LOS A            | 0.2               | 1.1           | 0.14      | 0.50           | 0.14                | 37.8        |
| Approach                     |      |           | 25                    | 0.0 | 25                    | 0.0 | 0.032     | 4.9         | LOS A            | 0.2               | 1.1           | 0.14      | 0.50           | 0.14                | 37.8        |
| All Vehicles                 |      |           | 1726                  | 2.5 | 1726                  | 2.5 | 0.491     | 7.6         | LOS A            | 7.3               | 51.5          | 0.26      | 0.38           | 0.26                | 41.0        |

Site Level of Service (LOS) Method: Delay (RTA NSW). Site LOS Method is specified in the Network Data dialog (Override Site Data tab).

Vehicle movement LOS values are based on average delay per movement.

Intersection and Approach LOS values are based on average delay for all vehicle movements.

Delay Model: SIDRA Standard (Control Delay: Geometric Delay is included).

Queue Model: SIDRA queue estimation methods are used for Back of Queue and Queue at Start of Green.

Gap-Acceptance Capacity Formula: SIDRA Standard (Akçelik M3D).

HV (%) values are calculated for All Movement Classes of All Heavy Vehicle Model Designation.

Arrival Flows used in performance calculations are adjusted to include any Initial Queued Demand and Upstream Capacity Constraint effects.

\* Critical Movement (Signal Timing)

| Pedestrian Movement Performance |                 |                    |                    |                  |  |     |           |                |                    |                   |                      |
|---------------------------------|-----------------|--------------------|--------------------|------------------|--|-----|-----------|----------------|--------------------|-------------------|----------------------|
| Mov ID                          | Crossing        | Dem. Flow<br>ped/h | Aver. Delay<br>sec | Level of Service | AVERAGE BACK OF QUEUE<br>[ Ped Dist ]<br>ped m |     | Prop. Que | Eff. Stop Rate | Travel Time<br>sec | Travel Dist.<br>m | Aver. Speed<br>m/sec |
| SouthEast: Pacific Hwy (SE)     |                 |                    |                    |                  |  |     |           |                |                    |                   |                      |
| P1                              | Full            | 37                 | 33.9               | LOS D            | 0.1  | 0.1 | 0.87      | 0.87           | 50.5               | 20.0              | 0.40                 |
| East: Berry St (E)              |                 |                    |                    |                  |  |     |           |                |                    |                   |                      |
| P2                              | Full            | 66                 | 36.6               | LOS D            | 0.2  | 0.2 | 0.90      | 0.90           | 203.2              | 200.0             | 0.98                 |
| NorthWest: Pacific Hwy (NW)     |                 |                    |                    |                  |  |     |           |                |                    |                   |                      |
| P3B                             | Slip/<br>Bypass | 66                 | 36.6               | LOS D            | 0.2  | 0.2 | 0.90      | 0.90           | 53.2               | 20.0              | 0.38                 |
| SouthWest: Berry St (SW)        |                 |                    |                    |                  |  |     |           |                |                    |                   |                      |
| P4                              | Full            | 85                 | 1.0                | LOS A            | 0.0  | 0.0 | 0.21      | 0.21           | 17.7               | 20.0              | 1.13                 |
| All Pedestrians                 |                 | 255                | 24.3               | LOS C            | 0.2  | 0.2 | 0.67      | 0.67           | 80.0               | 66.9              | 0.84                 |

Level of Service (LOS) Method: SIDRA Pedestrian LOS Method (Based on Average Delay)

Pedestrian movement LOS values are based on average delay per pedestrian movement.

Intersection LOS value for Pedestrians is based on average delay for all pedestrian movements.

---

**SIDRA INTERSECTION 9.1 | Copyright © 2000-2022 Akcelik and Associates Pty Ltd | sidrasolutions.com**

Organisation: AECOM AUSTRALIA PTY LTD | Licence: NETWORK / Enterprise Level 1 | Processed: Friday, 14 July 2023 9:58:15 AM

Project: C:\Users\YeungM\AECOM\ANZ-NAC-Sydney Metro-Sydney Metro C&SW Operational Monitoring - General\400\_Technical\432\_Traffic Analysis\SIDRA Modelling\01 Models (Geometry Only)\Block 1\Rev1\Review03 SM C&SW\_VIC (Block 1)\_PS.sip9

# MOVEMENT SUMMARY

Site: VIC02 [VIC02 Miller St / Berry St (Site Folder: Block 1 Model - 2023 Weekend Peak )]

Output produced by SIDRA INTERSECTION Version: 9.1.1.200

Network: N101 [VIC Network 1 (Network Folder: Block 1 Network - 2023 Weekend Peak)]

TCS 874

Site Category: (None)

Signals - EQUISAT (Fixed-Time/SCATS) Coordinated Cycle Time = 90 seconds (Network Site User-Given Phase Times)

| Vehicle Movement Performance |      |           |              |              |               |              |           |             |                  |                   |            |           |                |                     |             |
|------------------------------|------|-----------|--------------|--------------|---------------|--------------|-----------|-------------|------------------|-------------------|------------|-----------|----------------|---------------------|-------------|
| Mov ID                       | Turn | Mov Class | Demand Flows |              | Arrival Flows |              | Deg. Satn | Aver. Delay | Level of Service | 95% Back Of Queue |            | Prop. Que | Eff. Stop Rate | Aver. No. of Cycles | Aver. Speed |
|                              |      |           | [ Total HV ] | [ Total HV ] | [ Total HV ]  | [ Total HV ] |           |             |                  | [ Veh. veh        | [ Dist ] m |           |                |                     |             |
|                              |      |           | veh/h        | %            | veh/h         | %            | v/c       | sec         |                  |                   |            |           |                |                     | km/h        |
| South: Miller St (S)         |      |           |              |              |               |              |           |             |                  |                   |            |           |                |                     |             |
| 2                            | T1   | All MCs   | 281          | 3.0          | 281           | 3.0          | 0.748     | 18.0        | LOS B            | 7.7               | 55.0       | 0.75      | 0.69           | 0.76                | 18.4        |
| 3                            | R2   | All MCs   | 127          | 0.8          | 127           | 0.8          | *0.748    | 35.1        | LOS C            | 7.7               | 55.0       | 0.89      | 0.93           | 0.93                | 21.0        |
| Approach                     |      |           | 408          | 2.3          | 408           | 2.3          | 0.748     | 23.3        | LOS B            | 7.7               | 55.0       | 0.79      | 0.76           | 0.81                | 19.5        |
| North: Miller St (N)         |      |           |              |              |               |              |           |             |                  |                   |            |           |                |                     |             |
| 7                            | L2   | All MCs   | 146          | 1.4          | 146           | 1.4          | *0.720    | 49.5        | LOS D            | 6.7               | 47.8       | 1.00      | 0.89           | 1.14                | 16.1        |
| 8                            | T1   | All MCs   | 178          | 4.1          | 178           | 4.1          | 0.450     | 34.1        | LOS C            | 7.0               | 50.5       | 0.92      | 0.75           | 0.92                | 14.4        |
| Approach                     |      |           | 324          | 2.9          | 324           | 2.9          | 0.720     | 41.0        | LOS C            | 7.0               | 50.5       | 0.96      | 0.81           | 1.02                | 15.4        |
| West: Berry St (W)           |      |           |              |              |               |              |           |             |                  |                   |            |           |                |                     |             |
| 10                           | L2   | All MCs   | 86           | 0.0          | 86            | 0.0          | 0.135     | 29.9        | LOS C            | 3.1               | 21.7       | 0.86      | 0.74           | 0.86                | 11.0        |
| 11                           | T1   | All MCs   | 565          | 1.5          | 565           | 1.5          | 0.369     | 21.2        | LOS B            | 10.2              | 72.2       | 0.80      | 0.68           | 0.80                | 21.8        |
| 12                           | R2   | All MCs   | 2840.7       | 0.7          | 2840.7        | 0.7          | *0.369    | 30.8        | LOS C            | 9.3               | 68.3       | 0.79      | 0.69           | 0.79                | 13.8        |
| Approach                     |      |           | 680          | 2.9          | 680           | 2.9          | 0.369     | 22.7        | LOS B            | 10.2              | 72.2       | 0.81      | 0.69           | 0.81                | 20.3        |
| All Vehicles                 |      |           | 1413         | 2.8          | 1413          | 2.8          | 0.748     | 27.1        | LOS B            | 10.2              | 72.2       | 0.84      | 0.74           | 0.86                | 18.6        |

Site Level of Service (LOS) Method: Delay (RTA NSW). Site LOS Method is specified in the Network Data dialog (Override Site Data tab).

Vehicle movement LOS values are based on average delay per movement.

Intersection and Approach LOS values are based on average delay for all vehicle movements.

Delay Model: SIDRA Standard (Control Delay: Geometric Delay is included).

Queue Model: SIDRA queue estimation methods are used for Back of Queue and Queue at Start of Green.

Gap-Acceptance Capacity Formula: SIDRA Standard (Akçelik M3D).

HV (%) values are calculated for All Movement Classes of All Heavy Vehicle Model Designation.

Arrival Flows used in performance calculations are adjusted to include any Initial Queued Demand and Upstream Capacity Constraint effects.

\* Critical Movement (Signal Timing)

| Pedestrian Movement Performance |          |           |             |                  |                       |        |           |                |             |              |             |
|---------------------------------|----------|-----------|-------------|------------------|-----------------------|--------|-----------|----------------|-------------|--------------|-------------|
| Mov ID                          | Crossing | Dem. Flow | Aver. Delay | Level of Service | AVERAGE BACK OF QUEUE |        | Prop. Que | Eff. Stop Rate | Travel Time | Travel Dist. | Aver. Speed |
|                                 |          | ped/h     | sec         |                  | [ Ped                 | Dist ] |           |                | sec         | m            | m/sec       |
|                                 |          |           |             |                  | ped                   | m      |           |                |             |              |             |
| South: Miller St (S)            |          |           |             |                  |                       |        |           |                |             |              |             |
| P1                              | Full     | 91        | 36.6        | LOS D            | 0.2                   | 0.2    | 0.90      | 0.90           | 53.3        | 20.0         | 0.38        |
| East: Berry St (E)              |          |           |             |                  |                       |        |           |                |             |              |             |
| P2                              | Full     | 89        | 37.5        | LOS D            | 0.2                   | 0.2    | 0.91      | 0.91           | 54.2        | 20.0         | 0.37        |
| North: Miller St (N)            |          |           |             |                  |                       |        |           |                |             |              |             |
| P3                              | Full     | 57        | 34.8        | LOS D            | 0.1                   | 0.1    | 0.88      | 0.88           | 51.4        | 20.0         | 0.39        |
| West: Berry St (W)              |          |           |             |                  |                       |        |           |                |             |              |             |
| P4                              | Full     | 116       | 37.5        | LOS D            | 0.3                   | 0.3    | 0.92      | 0.92           | 54.2        | 20.0         | 0.37        |
| All Pedestrians                 |          | 353       | 36.8        | LOS D            | 0.3                   | 0.3    | 0.91      | 0.91           | 53.5        | 20.0         | 0.37        |

Level of Service (LOS) Method: SIDRA Pedestrian LOS Method (Based on Average Delay)

Pedestrian movement LOS values are based on average delay per pedestrian movement.

Intersection LOS value for Pedestrians is based on average delay for all pedestrian movements.

**SIDRA INTERSECTION 9.1 | Copyright © 2000-2022 Akcelik and Associates Pty Ltd | sidrasolutions.com**

Organisation: AECOM AUSTRALIA PTY LTD | Licence: NETWORK / Enterprise Level 1 | Processed: Friday, 14 July 2023 9:58:15 AM

Project: C:\Users\YeungMA\AECOM\ANZ-NAC-Sydney Metro-Sydney Metro C&SW Operational Monitoring - General\400\_Technical\432\_Traffic Analysis\SIDRA Modelling\01 Models (Geometry Only)\Block 1\Rev1\_Review\03 SM C&SW\_VIC (Block 1)\_PS.sip9

# MOVEMENT SUMMARY

Site: VIC03 [VIC03 Miller St / McLaren St (Site Folder: Block 1 Model - 2023 Weekend Peak )]

Output produced by SIDRA INTERSECTION Version: 9.1.1.200

Network: N101 [VIC Network 1 (Network Folder: Block 1 Network - 2023 Weekend Peak)]

TCS 1156

Site Category: (None)

Signals - EQUISAT (Fixed-Time/SCATS) Isolated Cycle Time = 71 seconds (Site User-Given Phase Times)

| Vehicle Movement Performance |      |           |                       |     |                       |     |           |             |                  |                   |               |           |                |                     |                  |
|------------------------------|------|-----------|-----------------------|-----|-----------------------|-----|-----------|-------------|------------------|-------------------|---------------|-----------|----------------|---------------------|------------------|
| Mov ID                       | Turn | Mov Class | Demand Flows          |     | Arrival Flows         |     | Deg. Satn | Aver. Delay | Level of Service | 95% Back Of Queue |               | Prop. Que | Eff. Stop Rate | Aver. No. of Cycles | Aver. Speed km/h |
|                              |      |           | [ Total HV ]<br>veh/h | %   | [ Total HV ]<br>veh/h | %   |           |             |                  | [ Veh. veh        | [ Dist ]<br>m |           |                |                     |                  |
| South: Miller St (S)         |      |           |                       |     |                       |     |           |             |                  |                   |               |           |                |                     |                  |
| 1                            | L2   | All MCs   | 74                    | 0.0 | 74                    | 0.0 | 0.064     | 9.3         | LOS A            | 1.0               | 7.0           | 0.42      | 0.59           | 0.42                | 34.3             |
| 2                            | T1   | All MCs   | 283                   | 3.0 | 283                   | 3.0 | 0.292     | 7.4         | LOS A            | 5.2               | 37.3          | 0.53      | 0.47           | 0.53                | 35.6             |
| 3                            | R2   | All MCs   | 22                    | 0.0 | 22                    | 0.0 | 0.292     | 14.3        | LOS A            | 5.2               | 37.3          | 0.53      | 0.47           | 0.53                | 30.1             |
| Approach                     |      |           | 379                   | 2.2 | 379                   | 2.2 | 0.292     | 8.2         | LOS A            | 5.2               | 37.3          | 0.51      | 0.49           | 0.51                | 35.1             |
| East: McLaren St (E)         |      |           |                       |     |                       |     |           |             |                  |                   |               |           |                |                     |                  |
| 4                            | L2   | All MCs   | 41                    | 0.0 | 41                    | 0.0 | 0.262     | 40.2        | LOS C            | 1.4               | 10.0          | 0.97      | 0.73           | 0.97                | 12.1             |
| 5                            | T1   | All MCs   | 81                    | 0.0 | 81                    | 0.0 | *0.227    | 27.4        | LOS B            | 2.5               | 17.3          | 0.89      | 0.69           | 0.89                | 26.0             |
| Approach                     |      |           | 122                   | 0.0 | 122                   | 0.0 | 0.262     | 31.7        | LOS C            | 2.5               | 17.3          | 0.92      | 0.70           | 0.92                | 21.6             |
| North: Miller St (N)         |      |           |                       |     |                       |     |           |             |                  |                   |               |           |                |                     |                  |
| 7                            | L2   | All MCs   | 35                    | 0.0 | 35                    | 0.0 | 0.063     | 13.8        | LOS A            | 1.0               | 7.3           | 0.49      | 0.58           | 0.49                | 20.0             |
| 8                            | T1   | All MCs   | 262                   | 3.6 | 262                   | 3.6 | 0.316     | 9.4         | LOS A            | 5.3               | 38.4          | 0.56      | 0.61           | 0.56                | 29.5             |
| 9                            | R2   | All MCs   | 57                    | 0.0 | 57                    | 0.0 | *0.316    | 15.9        | LOS B            | 5.3               | 38.4          | 0.57      | 0.61           | 0.57                | 36.0             |
| Approach                     |      |           | 354                   | 2.7 | 354                   | 2.7 | 0.316     | 10.9        | LOS A            | 5.3               | 38.4          | 0.55      | 0.61           | 0.55                | 29.4             |
| West: McLaren St (W)         |      |           |                       |     |                       |     |           |             |                  |                   |               |           |                |                     |                  |
| 10                           | L2   | All MCs   | 60                    | 1.8 | 60                    | 1.8 | 0.146     | 29.3        | LOS C            | 1.7               | 12.1          | 0.84      | 0.73           | 0.84                | 25.7             |
| 11                           | T1   | All MCs   | 54                    | 0.0 | 54                    | 0.0 | 0.219     | 22.3        | LOS B            | 2.1               | 15.2          | 0.87      | 0.67           | 0.87                | 23.6             |
| 12                           | R2   | All MCs   | 20                    | 5.3 | 20                    | 5.3 | *0.219    | 34.9        | LOS C            | 2.1               | 15.2          | 0.87      | 0.67           | 0.87                | 20.6             |
| Approach                     |      |           | 134                   | 1.6 | 134                   | 1.6 | 0.219     | 27.3        | LOS B            | 2.1               | 15.2          | 0.86      | 0.70           | 0.86                | 24.3             |
| All Vehicles                 |      |           | 988                   | 2.0 | 988                   | 2.0 | 0.316     | 14.7        | LOS B            | 5.3               | 38.4          | 0.62      | 0.59           | 0.62                | 29.5             |

Site Level of Service (LOS) Method: Delay (RTA NSW). Site LOS Method is specified in the Network Data dialog (Override Site Data tab).

Vehicle movement LOS values are based on average delay per movement.

Intersection and Approach LOS values are based on average delay for all vehicle movements.

Delay Model: SIDRA Standard (Control Delay: Geometric Delay is included).

Queue Model: SIDRA queue estimation methods are used for Back of Queue and Queue at Start of Green.

Gap-Acceptance Capacity Formula: SIDRA Standard (Akçelik M3D).

HV (%) values are calculated for All Movement Classes of All Heavy Vehicle Model Designation.

Arrival Flows used in performance calculations are adjusted to include any Initial Queued Demand and Upstream Capacity Constraint effects.

\* Critical Movement (Signal Timing)



| Pedestrian Movement Performance |          |           |             |                  |                       |        |           |                |             |              |             |
|---------------------------------|----------|-----------|-------------|------------------|-----------------------|--------|-----------|----------------|-------------|--------------|-------------|
| Mov ID                          | Crossing | Dem. Flow | Aver. Delay | Level of Service | AVERAGE BACK OF QUEUE |        | Prop. Que | Eff. Stop Rate | Travel Time | Travel Dist. | Aver. Speed |
|                                 |          | ped/h     | sec         |                  | [ Ped                 | Dist ] |           |                | sec         | m            | m/sec       |
|                                 |          |           |             |                  | ped                   | m      |           |                |             |              |             |
| South: Miller St (S)            |          |           |             |                  |                       |        |           |                |             |              |             |
| P1                              | Full     | 48        | 24.6        | LOS C            | 0.1                   | 0.1    | 0.83      | 0.83           | 41.2        | 20.0         | 0.49        |
| East: McLaren St (E)            |          |           |             |                  |                       |        |           |                |             |              |             |
| P2                              | Full     | 61        | 26.3        | LOS C            | 0.1                   | 0.1    | 0.86      | 0.86           | 42.9        | 20.0         | 0.47        |
| North: Miller St (N)            |          |           |             |                  |                       |        |           |                |             |              |             |
| P3                              | Full     | 47        | 25.4        | LOS C            | 0.1                   | 0.1    | 0.85      | 0.85           | 42.1        | 20.0         | 0.48        |
| West: McLaren St (W)            |          |           |             |                  |                       |        |           |                |             |              |             |
| P4                              | Full     | 71        | 25.4        | LOS C            | 0.1                   | 0.1    | 0.85      | 0.85           | 42.1        | 20.0         | 0.48        |
| All Pedestrians                 |          | 227       | 25.5        | LOS C            | 0.1                   | 0.1    | 0.85      | 0.85           | 42.1        | 20.0         | 0.47        |

Level of Service (LOS) Method: SIDRA Pedestrian LOS Method (Based on Average Delay)  
 Pedestrian movement LOS values are based on average delay per pedestrian movement.  
 Intersection LOS value for Pedestrians is based on average delay for all pedestrian movements.

# MOVEMENT SUMMARY

Site: VIC04 [VIC04 Pacific Hwy / Miller St (Site Folder: Block 1 Model - 2023 Weekend Peak )]

Output produced by SIDRA INTERSECTION Version: 9.1.1.200

Network: N101 [VIC Network 1 (Network Folder: Block 1 Network - 2023 Weekend Peak)]

TCS 630

Site Category: (None)

Signals - EQUISAT (Fixed-Time/SCATS) Coordinated Cycle Time = 90 seconds (Network Site User-Given Phase Times)

| Vehicle Movement Performance |      |           |              |      |               |      |           |             |                  |                   |          |           |                |                     |             |
|------------------------------|------|-----------|--------------|------|---------------|------|-----------|-------------|------------------|-------------------|----------|-----------|----------------|---------------------|-------------|
| Mov ID                       | Turn | Mov Class | Demand Flows |      | Arrival Flows |      | Deg. Satn | Aver. Delay | Level of Service | 95% Back Of Queue |          | Prop. Que | Eff. Stop Rate | Aver. No. of Cycles | Aver. Speed |
|                              |      |           | [ Total HV ] | %    | [ Total HV ]  | %    |           |             |                  | [ Veh. veh        | Dist ] m |           |                |                     |             |
| South: Miller St (S)         |      |           |              |      |               |      |           |             |                  |                   |          |           |                |                     |             |
| 1                            | L2   | All MCs   | 2            | 0.0  | 2             | 0.0  | 0.137     | 16.3        | LOS B            | 2.6               | 20.3     | 0.59      | 0.61           | 0.59                | 29.0        |
| 1a                           | L1   | All MCs   | 105          | 13.0 | 105           | 13.0 | 0.137     | 16.9        | LOS B            | 2.6               | 20.3     | 0.59      | 0.61           | 0.59                | 21.3        |
| 2                            | T1   | All MCs   | 209          | 4.0  | 209           | 4.0  | *0.607    | 35.2        | LOS C            | 9.2               | 66.8     | 0.96      | 0.80           | 0.96                | 13.9        |
| 3b                           | R3   | All MCs   | 17           | 0.0  | 17            | 0.0  | 0.607     | 43.4        | LOS D            | 9.2               | 66.8     | 0.96      | 0.80           | 0.96                | 21.8        |
| Approach                     |      |           | 334          | 6.6  | 334           | 6.6  | 0.607     | 29.8        | LOS C            | 9.2               | 66.8     | 0.84      | 0.74           | 0.84                | 16.2        |
| SouthEast: Pacific Hwy (SE)  |      |           |              |      |               |      |           |             |                  |                   |          |           |                |                     |             |
| 21b                          | L3   | All MCs   | 154          | 1.4  | 154           | 1.4  | 0.158     | 8.5         | LOS A            | 1.6               | 11.4     | 0.38      | 0.68           | 0.38                | 37.4        |
| 21a                          | L1   | All MCs   | 19           | 5.6  | 19            | 5.6  | 0.158     | 22.9        | LOS B            | 1.6               | 11.4     | 0.38      | 0.68           | 0.38                | 37.9        |
| 22                           | T1   | All MCs   | 618          | 1.0  | 618           | 1.0  | *0.480    | 25.8        | LOS B            | 10.8              | 76.5     | 0.84      | 0.72           | 0.84                | 20.9        |
| 23a                          | R1   | All MCs   | 199          | 0.5  | 199           | 0.5  | *0.554    | 40.8        | LOS C            | 8.1               | 57.2     | 0.96      | 0.80           | 0.96                | 15.6        |
| Approach                     |      |           | 989          | 1.1  | 989           | 1.1  | 0.554     | 26.0        | LOS B            | 10.8              | 76.5     | 0.79      | 0.73           | 0.79                | 22.5        |
| North: Miller St (N)         |      |           |              |      |               |      |           |             |                  |                   |          |           |                |                     |             |
| 7a                           | L1   | All MCs   | 59           | 25.0 | 59            | 25.0 | 0.086     | 8.0         | LOS A            | 0.6               | 5.0      | 0.24      | 0.45           | 0.24                | 36.3        |
| 8                            | T1   | All MCs   | 128          | 2.5  | 128           | 2.5  | 0.361     | 8.3         | LOS A            | 1.4               | 10.3     | 0.28      | 0.26           | 0.28                | 32.0        |
| 9                            | R2   | All MCs   | 5            | 0.0  | 5             | 0.0  | 0.361     | 14.1        | LOS A            | 1.4               | 10.3     | 0.31      | 0.31           | 0.31                | 32.5        |
| 9b                           | R3   | All MCs   | 14           | 7.7  | 14            | 7.7  | 0.361     | 14.7        | LOS B            | 1.4               | 10.3     | 0.31      | 0.31           | 0.31                | 26.5        |
| Approach                     |      |           | 206          | 9.2  | 206           | 9.2  | 0.361     | 8.8         | LOS A            | 1.4               | 10.3     | 0.27      | 0.32           | 0.27                | 33.0        |
| NorthWest: Pacific Hwy (NW)  |      |           |              |      |               |      |           |             |                  |                   |          |           |                |                     |             |
| 28                           | T1   | All MCs   | 166          | 1.3  | 166           | 1.3  | 0.130     | 14.2        | LOS A            | 1.7               | 11.9     | 0.48      | 0.38           | 0.48                | 39.4        |
| 29a                          | R1   | All MCs   | 163          | 0.6  | 163           | 0.6  | 0.455     | 46.6        | LOS D            | 7.2               | 50.7     | 1.00      | 0.84           | 1.00                | 19.9        |
| Approach                     |      |           | 329          | 1.0  | 329           | 1.0  | 0.455     | 30.2        | LOS C            | 7.2               | 50.7     | 0.74      | 0.61           | 0.74                | 26.7        |
| All Vehicles                 |      |           | 1859         | 2.9  | 1859          | 2.9  | 0.607     | 25.5        | LOS B            | 10.8              | 76.5     | 0.73      | 0.66           | 0.73                | 23.3        |

Site Level of Service (LOS) Method: Delay (RTA NSW). Site LOS Method is specified in the Network Data dialog (Override Site Data tab).

Vehicle movement LOS values are based on average delay per movement.

Intersection and Approach LOS values are based on average delay for all vehicle movements.

Delay Model: SIDRA Standard (Control Delay: Geometric Delay is included).

Queue Model: SIDRA queue estimation methods are used for Back of Queue and Queue at Start of Green.

Gap-Acceptance Capacity Formula: SIDRA Standard (Akçelik M3D).

HV (%) values are calculated for All Movement Classes of All Heavy Vehicle Model Designation.

Arrival Flows used in performance calculations are adjusted to include any Initial Queued Demand and Upstream Capacity Constraint effects.

\* Critical Movement (Signal Timing)

| Pedestrian Movement Performance |          |           |             |                  |                       |        |           |                |             |              |             |
|---------------------------------|----------|-----------|-------------|------------------|-----------------------|--------|-----------|----------------|-------------|--------------|-------------|
| Mov ID                          | Crossing | Dem. Flow | Aver. Delay | Level of Service | AVERAGE BACK OF QUEUE |        | Prop. Que | Eff. Stop Rate | Travel Time | Travel Dist. | Aver. Speed |
|                                 |          | ped/h     | sec         |                  | [ Ped                 | Dist ] |           |                | sec         | m            | m/sec       |
|                                 |          |           |             |                  | ped                   | m      |           |                |             |              |             |
| South: Miller St (S)            |          |           |             |                  |                       |        |           |                |             |              |             |
| P1                              | Full     | 98        | 34.8        | LOS D            | 0.2                   | 0.2    | 0.88      | 0.88           | 51.5        | 20.0         | 0.39        |
| SouthEast: Pacific Hwy (SE)     |          |           |             |                  |                       |        |           |                |             |              |             |
| P5                              | Full     | 59        | 33.0        | LOS D            | 0.1                   | 0.1    | 0.86      | 0.86           | 49.7        | 20.0         | 0.40        |
| North: Miller St (N)            |          |           |             |                  |                       |        |           |                |             |              |             |
| P3                              | Full     | 194       | 34.1        | LOS D            | 0.4                   | 0.4    | 0.87      | 0.87           | 50.7        | 20.0         | 0.39        |
| NorthWest: Pacific Hwy (NW)     |          |           |             |                  |                       |        |           |                |             |              |             |
| P7                              | Full     | 86        | 31.4        | LOS D            | 0.2                   | 0.2    | 0.84      | 0.84           | 48.0        | 20.0         | 0.42        |
| All Pedestrians                 |          | 437       | 33.6        | LOS D            | 0.4                   | 0.4    | 0.87      | 0.87           | 50.2        | 20.0         | 0.40        |

Level of Service (LOS) Method: SIDRA Pedestrian LOS Method (Based on Average Delay)

Pedestrian movement LOS values are based on average delay per pedestrian movement.

Intersection LOS value for Pedestrians is based on average delay for all pedestrian movements.

**SIDRA INTERSECTION 9.1 | Copyright © 2000-2022 Akcelik and Associates Pty Ltd | sidrasolutions.com**

Organisation: AECOM AUSTRALIA PTY LTD | Licence: NETWORK / Enterprise Level 1 | Processed: Friday, 14 July 2023 9:58:15 AM

Project: C:\Users\YeungMAECOMANZ-NAC-Sydney Metro-Sydney Metro C&SW Operational Monitoring - General\400\_Technical\432\_Traffic Analysis\SIDRA Modelling\01 Models (Geometry Only)\Block 1\Rev1\_Review\03 SM C&SW\_VIC (Block 1)\_PS.sip9

# MOVEMENT SUMMARY

Site: BUG01 [BGU01 Hickson Rd / Towns PI (Site Folder: Block 1 - 2023 AM Peak)]

Output produced by SIDRA INTERSECTION Version: 9.1.1.200

Network: BGU-N1 [BGU Network 1 (Network Folder: Block 1 Network - 2023 AM Peak)]

Site Category: (None)  
Give-Way (Two-Way)

| Vehicle Movement Performance |      |           |              |      |               |      |           |             |                  |                   |        |           |                |                     |             |
|------------------------------|------|-----------|--------------|------|---------------|------|-----------|-------------|------------------|-------------------|--------|-----------|----------------|---------------------|-------------|
| Mov ID                       | Turn | Mov Class | Demand Flows |      | Arrival Flows |      | Deg. Satn | Aver. Delay | Level of Service | 95% Back Of Queue |        | Prop. Que | Eff. Stop Rate | Aver. No. of Cycles | Aver. Speed |
|                              |      |           | [ Total HV ] | %    | [ Total HV ]  | %    |           |             |                  | [ Veh. veh        | Dist ] |           |                |                     |             |
|                              |      |           | veh/h        | %    | veh/h         | %    | v/c       | sec         |                  |                   | m      |           |                |                     | km/h        |
| East: Hickson Rd (E)         |      |           |              |      |               |      |           |             |                  |                   |        |           |                |                     |             |
| 4a                           | L1   | All MCs   | 97           | 19.6 | 97            | 19.6 | 0.148     | 4.5         | LOS A            | 0.6               | 5.0    | 0.39      | 0.54           | 0.39                | 37.3        |
| 6a                           | R1   | All MCs   | 57           | 1.9  | 57            | 1.9  | 0.148     | 5.8         | LOS A            | 0.6               | 5.0    | 0.39      | 0.54           | 0.39                | 34.9        |
| Approach                     |      |           | 154          | 13.0 | 154           | 13.0 | 0.148     | 5.0         | NA               | 0.6               | 5.0    | 0.39      | 0.54           | 0.39                | 36.8        |
| NorthWest: Towns PI (NW)     |      |           |              |      |               |      |           |             |                  |                   |        |           |                |                     |             |
| 27a                          | L1   | All MCs   | 104          | 10.1 | 104           | 10.1 | 0.269     | 5.0         | LOS A            | 1.1               | 8.3    | 0.56      | 0.73           | 0.60                | 33.9        |
| 29                           | R2   | All MCs   | 88           | 17.9 | 88            | 17.9 | 0.269     | 9.1         | LOS A            | 1.1               | 8.3    | 0.56      | 0.73           | 0.60                | 35.4        |
| Approach                     |      |           | 193          | 13.7 | 193           | 13.7 | 0.269     | 6.9         | LOS A            | 1.1               | 8.3    | 0.56      | 0.73           | 0.60                | 34.8        |
| SouthWest: Hickson Rd (SW)   |      |           |              |      |               |      |           |             |                  |                   |        |           |                |                     |             |
| 30                           | L2   | All MCs   | 126          | 10.0 | 126           | 10.0 | 0.281     | 4.5         | LOS A            | 1.5               | 11.3   | 0.35      | 0.46           | 0.35                | 37.2        |
| 32a                          | R1   | All MCs   | 246          | 11.5 | 246           | 11.5 | 0.281     | 3.2         | LOS A            | 1.5               | 11.3   | 0.35      | 0.46           | 0.35                | 37.9        |
| Approach                     |      |           | 373          | 11.0 | 373           | 11.0 | 0.281     | 3.7         | NA               | 1.5               | 11.3   | 0.35      | 0.46           | 0.35                | 37.7        |
| All Vehicles                 |      |           | 719          | 12.2 | 719           | 12.2 | 0.281     | 4.8         | NA               | 1.5               | 11.3   | 0.41      | 0.55           | 0.43                | 36.9        |

Site Level of Service (LOS) Method: Delay (RTA NSW). Site LOS Method is specified in the Network Data dialog (Override Site Data tab).

Vehicle movement LOS values are based on average delay per movement.

Minor Road Approach LOS values are based on average delay for all vehicle movements.

NA (TWSC): Level of Service is not defined for major road approaches or the intersection as a whole for Two-Way Sign Control (HCM LOS rule).

Two-Way Sign Control Capacity Model: SIDRA Standard.

Delay Model: SIDRA Standard (Control Delay: Geometric Delay is included).

Queue Model: SIDRA queue estimation methods are used for Back of Queue and Queue at Start of Gap.

Gap-Acceptance Capacity Formula: SIDRA Standard (Akçelik M3D).

HV (%) values are calculated for All Movement Classes of All Heavy Vehicle Model Designation.

Arrival Flows used in performance calculations are adjusted to include any Initial Queued Demand and Upstream Capacity Constraint effects.

---

**SIDRA INTERSECTION 9.1 | Copyright © 2000-2022 Akcelik and Associates Pty Ltd | sidrasolutions.com**

Organisation: AECOM AUSTRALIA PTY LTD | Licence: NETWORK / Enterprise Level 1 | Processed: Friday, 14 July 2023 3:11:10 PM

Project: C:\Users\Yeung\AECOM\ANZ-NAC-Sydney Metro-Sydney Metro C&SW Operational Monitoring - General\400\_Technical\432\_Traffic Analysis\SIDRA Modelling\01 Models (Geometry Only)\Block 1\Rev1\\_Review\04 SM C&SW\_BGU (Block 1)\_PS.sip9

# MOVEMENT SUMMARY

Site: BGU02 [BGU02 Dalgety Rd / Towns PI (Site Folder: Block 1 - 2023 AM Peak)]

Output produced by SIDRA INTERSECTION Version: 9.1.1.200

Network: BGU-N1 [BGU Network 1 (Network Folder: Block 1 Network - 2023 AM Peak)]

Site Category: (None)  
Roundabout

| Vehicle Movement Performance |      |           |              |      |               |      |           |             |                  |                   |          |           |                |                     |             |
|------------------------------|------|-----------|--------------|------|---------------|------|-----------|-------------|------------------|-------------------|----------|-----------|----------------|---------------------|-------------|
| Mov ID                       | Turn | Mov Class | Demand Flows |      | Arrival Flows |      | Deg. Satn | Aver. Delay | Level of Service | 95% Back Of Queue |          | Prop. Que | Eff. Stop Rate | Aver. No. of Cycles | Aver. Speed |
|                              |      |           | [ Total HV ] | %    | [ Total HV ]  | %    | v/c       | sec         |                  | [ Veh. veh        | Dist ] m |           |                |                     | km/h        |
| South: Dalgety Rd (S)        |      |           |              |      |               |      |           |             |                  |                   |          |           |                |                     |             |
| 30                           | L2   | All MCs   | 25           | 0.0  | 25            | 0.0  | 0.205     | 7.3         | LOS A            | 1.2               | 9.3      | 0.44      | 0.59           | 0.44                | 23.8        |
| 3b                           | R3   | All MCs   | 184          | 11.4 | 184           | 11.4 | 0.205     | 7.8         | LOS A            | 1.2               | 9.3      | 0.44      | 0.59           | 0.44                | 30.8        |
| 32u                          | U    | All MCs   | 4            | 0.0  | 4             | 0.0  | 0.205     | 8.2         | LOS A            | 1.2               | 9.3      | 0.44      | 0.59           | 0.44                | 33.9        |
| Approach                     |      |           | 214          | 9.9  | 214           | 9.9  | 0.205     | 7.7         | LOS A            | 1.2               | 9.3      | 0.44      | 0.59           | 0.44                | 29.7        |
| SouthEast: Towns PI (SE)     |      |           |              |      |               |      |           |             |                  |                   |          |           |                |                     |             |
| 21b                          | L3   | All MCs   | 19           | 5.6  | 19            | 5.6  | 0.135     | 2.6         | LOS A            | 0.8               | 6.3      | 0.07      | 0.74           | 0.07                | 32.0        |
| 21a                          | L1   | All MCs   | 167          | 7.5  | 167           | 7.5  | 0.135     | 8.3         | LOS A            | 0.8               | 6.3      | 0.07      | 0.74           | 0.07                | 17.0        |
| 23u                          | U    | All MCs   | 15           | 57.1 | 15            | 57.1 | 0.135     | 7.2         | LOS A            | 0.8               | 6.3      | 0.07      | 0.74           | 0.07                | 23.7        |
| Approach                     |      |           | 201          | 11.0 | 201           | 11.0 | 0.135     | 7.6         | LOS A            | 0.8               | 6.3      | 0.07      | 0.74           | 0.07                | 19.0        |
| West: Parking Access (W)     |      |           |              |      |               |      |           |             |                  |                   |          |           |                |                     |             |
| 12a                          | R1   | All MCs   | 1            | 0.0  | 1             | 0.0  | 0.005     | 1.2         | LOS A            | 0.0               | 0.2      | 0.42      | 0.19           | 0.42                | 9.6         |
| 29                           | R2   | All MCs   | 3            | 0.0  | 3             | 0.0  | 0.005     | 1.2         | LOS A            | 0.0               | 0.2      | 0.42      | 0.19           | 0.42                | 21.3        |
| 29u                          | U    | All MCs   | 1            | 0.0  | 1             | 0.0  | 0.005     | 1.2         | LOS A            | 0.0               | 0.2      | 0.42      | 0.19           | 0.42                | 9.8         |
| Approach                     |      |           | 5            | 0.0  | 5             | 0.0  | 0.005     | 1.2         | LOS A            | 0.0               | 0.2      | 0.42      | 0.19           | 0.42                | 17.6        |
| All Vehicles                 |      |           | 420          | 10.3 | 420           | 10.3 | 0.205     | 7.6         | LOS A            | 1.2               | 9.3      | 0.26      | 0.66           | 0.26                | 24.5        |

Site Level of Service (LOS) Method: Delay (RTA NSW). Site LOS Method is specified in the Network Data dialog (Override Site Data tab).

Vehicle movement LOS values are based on average delay per movement.

Intersection and Approach LOS values are based on average delay for all vehicle movements.

Roundabout Capacity Model: SIDRA Standard.

Delay Model: SIDRA Standard (Control Delay: Geometric Delay is included).

Queue Model: SIDRA queue estimation methods are used for Back of Queue and Queue at Start of Gap.

Gap-Acceptance Capacity Formula: SIDRA Standard (Akçelik M3D).

HV (%) values are calculated for All Movement Classes of All Heavy Vehicle Model Designation.

Arrival Flows used in performance calculations are adjusted to include any Initial Queued Demand and Upstream Capacity Constraint effects.

---

**SIDRA INTERSECTION 9.1 | Copyright © 2000-2022 Akcelik and Associates Pty Ltd | sidrasolutions.com**

Organisation: AECOM AUSTRALIA PTY LTD | Licence: NETWORK / Enterprise Level 1 | Processed: Friday, 14 July 2023 3:11:10 PM

Project: C:\Users\Yeung\AECOM\ANZ-NAC-Sydney Metro-Sydney Metro C&SW Operational Monitoring - General\400\_Technical\432\_Traffic Analysis\SIDRA Modelling\01 Models (Geometry Only)\Block 1\Rev1\\_Review\04 SM C&SW\_BGU (Block 1)\_PS.sip9

# MOVEMENT SUMMARY

Site: **BGU03 [BGU03 Kent St / Argyle St (Site Folder: Block 1 - 2023 AM Peak)]**

Output produced by **SIDRA INTERSECTION Version: 9.1.1.200**

Site Category: (None)  
Give-Way (Two-Way)

| Vehicle Movement Performance |      |           |              |      |               |      |           |             |                  |                   |          |           |                |                     |             |
|------------------------------|------|-----------|--------------|------|---------------|------|-----------|-------------|------------------|-------------------|----------|-----------|----------------|---------------------|-------------|
| Mov ID                       | Turn | Mov Class | Demand Flows |      | Arrival Flows |      | Deg. Satn | Aver. Delay | Level of Service | 95% Back Of Queue |          | Prop. Que | Eff. Stop Rate | Aver. No. of Cycles | Aver. Speed |
|                              |      |           | [ Total HV ] | %    | [ Total HV ]  | %    |           |             |                  | [ Veh. ]          | [ Dist ] |           |                |                     |             |
|                              |      |           | veh/h        | %    | veh/h         | %    | v/c       | sec         |                  | veh               | m        |           |                |                     | km/h        |
| South: Kent St (S)           |      |           |              |      |               |      |           |             |                  |                   |          |           |                |                     |             |
| 1                            | L2   | All MCs   | 67           | 1.6  | 67            | 1.6  | 0.511     | 5.9         | LOSA             | 3.5               | 25.5     | 0.66      | 0.86           | 1.01                | 33.7        |
| 2                            | T1   | All MCs   | 31           | 3.4  | 31            | 3.4  | 0.511     | 7.0         | LOSA             | 3.5               | 25.5     | 0.66      | 0.86           | 1.01                | 32.1        |
| 3                            | R2   | All MCs   | 212          | 5.0  | 212           | 5.0  | 0.511     | 13.1        | LOSA             | 3.5               | 25.5     | 0.66      | 0.86           | 1.01                | 32.4        |
| Approach                     |      |           | 309          | 4.1  | 309           | 4.1  | 0.511     | 11.0        | LOSA             | 3.5               | 25.5     | 0.66      | 0.86           | 1.01                | 32.7        |
| East: Argyle St (E)          |      |           |              |      |               |      |           |             |                  |                   |          |           |                |                     |             |
| 4                            | L2   | All MCs   | 2            | 0.0  | 2             | 0.0  | 0.224     | 4.6         | LOSA             | 1.1               | 8.2      | 0.46      | 0.48           | 0.46                | 36.6        |
| 5                            | T1   | All MCs   | 98           | 7.5  | 98            | 7.5  | 0.224     | 2.1         | LOSA             | 1.1               | 8.2      | 0.46      | 0.48           | 0.46                | 36.2        |
| 6                            | R2   | All MCs   | 135          | 5.5  | 135           | 5.5  | 0.224     | 5.0         | LOSA             | 1.1               | 8.2      | 0.46      | 0.48           | 0.46                | 31.2        |
| Approach                     |      |           | 235          | 6.3  | 235           | 6.3  | 0.224     | 3.8         | NA               | 1.1               | 8.2      | 0.46      | 0.48           | 0.46                | 34.0        |
| North: Kent St (N)           |      |           |              |      |               |      |           |             |                  |                   |          |           |                |                     |             |
| 7                            | L2   | All MCs   | 8            | 12.5 | 8             | 12.5 | 0.028     | 8.7         | LOSA             | 0.1               | 0.7      | 0.43      | 0.91           | 0.43                | 27.5        |
| 8                            | T1   | All MCs   | 12           | 0.0  | 12            | 0.0  | 0.028     | 8.8         | LOSA             | 0.1               | 0.7      | 0.43      | 0.91           | 0.43                | 33.7        |
| 9                            | R2   | All MCs   | 2            | 0.0  | 2             | 0.0  | 0.028     | 9.7         | LOSA             | 0.1               | 0.7      | 0.43      | 0.91           | 0.43                | 30.9        |
| Approach                     |      |           | 22           | 4.8  | 22            | 4.8  | 0.028     | 8.8         | LOSA             | 0.1               | 0.7      | 0.43      | 0.91           | 0.43                | 31.9        |
| West: Argyle PI (W)          |      |           |              |      |               |      |           |             |                  |                   |          |           |                |                     |             |
| 10                           | L2   | All MCs   | 1            | 0.0  | 1             | 0.0  | 0.142     | 3.4         | LOSA             | 0.7               | 5.3      | 0.38      | 0.35           | 0.38                | 35.4        |
| 11                           | T1   | All MCs   | 85           | 14.8 | 85            | 14.8 | 0.142     | 2.2         | LOSA             | 0.7               | 5.3      | 0.38      | 0.35           | 0.38                | 37.0        |
| 12                           | R2   | All MCs   | 53           | 14.0 | 53            | 14.0 | 0.142     | 4.1         | LOSA             | 0.7               | 5.3      | 0.38      | 0.35           | 0.38                | 37.4        |
| Approach                     |      |           | 139          | 14.4 | 139           | 14.4 | 0.142     | 2.9         | NA               | 0.7               | 5.3      | 0.38      | 0.35           | 0.38                | 37.2        |
| All Vehicles                 |      |           | 705          | 6.9  | 705           | 6.9  | 0.511     | 6.9         | NA               | 3.5               | 25.5     | 0.53      | 0.63           | 0.68                | 33.8        |

Site Level of Service (LOS) Method: Delay (RTA NSW). Site LOS Method is specified in the Parameter Settings dialog (Options tab).

Vehicle movement LOS values are based on average delay per movement.

Minor Road Approach LOS values are based on average delay for all vehicle movements.

NA (TWSC): Level of Service is not defined for major road approaches or the intersection as a whole for Two-Way Sign Control (HCM LOS rule).

Two-Way Sign Control Capacity Model: SIDRA Standard.

Delay Model: SIDRA Standard (Control Delay: Geometric Delay is included).

Queue Model: SIDRA queue estimation methods are used for Back of Queue and Queue at Start of Gap.

Gap-Acceptance Capacity Formula: SIDRA Standard (Akçelik M3D).

HV (%) values are calculated for All Movement Classes of All Heavy Vehicle Model Designation.

Arrival Flows used in performance calculations are adjusted to include any Initial Queued Demand and Upstream Capacity Constraint effects.



---

**SIDRA INTERSECTION 9.1 | Copyright © 2000-2022 Akcelik and Associates Pty Ltd | sidrasolutions.com**

Organisation: AECOM AUSTRALIA PTY LTD | Licence: NETWORK / Enterprise Level 1 | Processed: Thursday, 13 July 2023 6:31:50 PM

Project: C:\Users\Yeung\AECOMANZ-NAC-Sydney Metro-Sydney Metro C&SW Operational Monitoring - General\400\_Technical\432\_Traffic Analysis\SIDRA Modelling\01 Models (Geometry Only)\Block 1\Rev1\\_Review\04 SM C&SW\_BGU (Block 1)\_PS.sip9

# CCG MOVEMENT SUMMARY

Common Control Group: CCG1 [TCS 4272]

Output produced by SIDRA INTERSECTION Version: 9.1.3.210

Network: BGU-N2 [BGU Network 2 (Network Folder: Block 1 Network - 2023 AM Peak)]

EQUISAT (Fixed-Time/SCATS) Coordinated Cycle Time = 85 seconds (CCG User-Given Phase Times)

| Vehicle Movement Performance (CCG)                                       |      |           |              |     |               |     |           |             |                  |                   |        |           |                |                     |             |
|--|------|-----------|--------------|-----|---------------|-----|-----------|-------------|------------------|-------------------|--------|-----------|----------------|---------------------|-------------|
| Mov ID   | Turn | Mov Class | Demand Flows |     | Arrival Flows |     | Deg. Satn | Aver. Delay | Level of Service | 95% Back Of Queue |        | Prop. Que | Eff. Stop Rate | Aver. No. of Cycles | Aver. Speed |
|  |      |           | [ Total HV ] | %   | [ Total HV ]  | %   |           |             |                  | [ Veh. veh        | Dist ] |           |                |                     |             |
| Site: BGU04 [BGU04 Pedestrian Mid-block Crossing at Kent St near Gas Ln] |      |           |              |     |               |     |           |             |                  |                   |        |           |                |                     |             |
| South: Kent St   |      |           |              |     |               |     |           |             |                  |                   |        |           |                |                     |             |
| 2  | T1   | All MCs   | 464          | 6.1 | 464           | 6.1 | 0.421     | 10.8        | LOS A            | 11.1              | 81.6   | 0.62      | 0.54           | 0.62                | 32.3        |
| Approach   |      |           | 464          | 6.1 | 464           | 6.1 | 0.421     | 10.8        | LOS A            | 11.1              | 81.6   | 0.62      | 0.54           | 0.62                | 32.3        |
| North: Kent St   |      |           |              |     |               |     |           |             |                  |                   |        |           |                |                     |             |
| 8  | T1   | All MCs   | 261          | 4.0 | 261           | 4.0 | 0.430     | 34.8        | LOS C            | 5.4               | 39.3   | 0.94      | 0.75           | 0.94                | 21.5        |
| Approach   |      |           | 261          | 4.0 | 261           | 4.0 | 0.430     | 34.8        | LOS C            | 5.4               | 39.3   | 0.94      | 0.75           | 0.94                | 21.5        |
| All Vehicles   |      |           | 725          | 5.4 | 725           | 5.4 | 0.430     | 19.4        | LOS B            | 11.1              | 81.6   | 0.74      | 0.61           | 0.74                | 27.6        |
| Site: BGU05 [BGU05 Kent St / Sydney Harbour Bridge (SHB) On-ramp]        |      |           |              |     |               |     |           |             |                  |                   |        |           |                |                     |             |
| South: Kent St (S)   |      |           |              |     |               |     |           |             |                  |                   |        |           |                |                     |             |
| 2  | T1   | All MCs   | 308          | 6.5 | 308           | 6.5 | 0.561     | 6.4         | LOS A            | 5.7               | 41.8   | 0.46      | 0.41           | 0.46                | 30.4        |
| 3a   | R1   | All MCs   | 409          | 8.0 | 409           | 8.0 | *0.506    | 23.8        | LOS B            | 7.6               | 58.2   | 0.75      | 0.69           | 0.75                | 22.2        |
| Approach   |      |           | 718          | 7.3 | 718           | 7.3 | 0.561     | 16.3        | LOS B            | 7.6               | 58.2   | 0.63      | 0.57           | 0.63                | 24.4        |
| East: Clarence St (E)  |      |           |              |     |               |     |           |             |                  |                   |        |           |                |                     |             |
| 4  | L2   | All MCs   | 148          | 1.4 | 148           | 1.4 | 0.531     | 40.6        | LOS C            | 5.9               | 41.9   | 0.97      | 0.79           | 0.97                | 11.4        |
| 6  | R2   | All MCs   | 186          | 4.5 | 186           | 4.5 | *0.894    | 57.0        | LOS E            | 10.0              | 72.7   | 1.00      | 1.16           | 1.52                | 8.9         |
| Approach   |      |           | 335          | 3.1 | 335           | 3.1 | 0.894     | 49.7        | LOS D            | 10.0              | 72.7   | 0.99      | 1.00           | 1.28                | 9.8         |
| NorthEast: SHB On-ramp (NE)  |      |           |              |     |               |     |           |             |                  |                   |        |           |                |                     |             |
| 24a  | L1   | All MCs   | 66           | 0.0 | 66            | 0.0 | 0.059     | 31.4        | LOS C            | 2.2               | 6.0    | 0.86      | 0.65           | 0.86                | 19.9        |
| Approach   |      |           | 66           | 0.0 | 66            | 0.0 | 0.059     | 31.4        | LOS C            | 2.2               | 6.0    | 0.86      | 0.65           | 0.86                | 19.9        |
| North: Kent St (N)   |      |           |              |     |               |     |           |             |                  |                   |        |           |                |                     |             |
| 7b   | L3   | All MCs   | 185          | 4.5 | 185           | 4.5 | 0.507     | 43.7        | LOS D            | 7.8               | 56.8   | 1.00      | 0.86           | 1.00                | 12.2        |
| 8  | T1   | All MCs   | 113          | 1.9 | 113           | 1.9 | *0.455    | 14.1        | LOS A            | 2.3               | 16.4   | 0.50      | 0.39           | 0.50                | 11.9        |
| Approach   |      |           | 298          | 3.5 | 298           | 3.5 | 0.507     | 32.5        | LOS C            | 7.8               | 56.8   | 0.81      | 0.68           | 0.81                | 12.1        |
| All Vehicles   |      |           | 1417         | 5.2 | 1417          | 5.2 | 0.894     | 28.3        | LOS B            | 10.0              | 72.7   | 0.76      | 0.70           | 0.83                | 17.4        |

Site Level of Service (LOS) Method: Delay (RTA NSW). Site LOS Method is specified in the Network Data dialog (Override Site Data tab).

Vehicle movement LOS values are based on average delay per movement.

Intersection and Approach LOS values are based on average delay for all vehicle movements.

Delay Model: SIDRA Standard (Control Delay: Geometric Delay is included).

Gap-Acceptance Capacity Formula: SIDRA Standard (Akçelik M3D).

HV (%) values are calculated for All Movement Classes of All Heavy Vehicle Model Designation.

Arrival Flows used in performance calculations are adjusted to include any Initial Queued Demand and Upstream Capacity Constraint effects.

\* Critical Movement (Signal Timing)

| Pedestrian Movement Performance (CCG)                                    |          |           |             |                  |                                    |     |           |                |             |              |             |
|--|----------|-----------|-------------|------------------|------------------------------------|-----|-----------|----------------|-------------|--------------|-------------|
| Mov ID   | Crossing | Dem. Flow | Aver. Delay | Level of Service | AVERAGE BACK OF QUEUE [ Ped Dist ] |     | Prop. Que | Eff. Stop Rate | Travel Time | Travel Dist. | Aver. Speed |
|  |          | ped/h     | sec         |                  | ped                                | m   |           |                | sec         | m            | m/sec       |
| Site: BGU04 [BGU04 Pedestrian Mid-block Crossing at Kent St near Gas Ln] |          |           |             |                  |                                    |     |           |                |             |              |             |
| South: Kent St   |          |           |             |                  |                                    |     |           |                |             |              |             |
| P1   | Full     | 144       | 36.0        | LOS D            | 0.3                                | 0.3 | 0.92      | 0.92           | 202.7       | 200.0        | 0.99        |
| All Pedestrians  |          | 144       | 36.0        | LOS D            | 0.3                                | 0.3 | 0.92      | 0.92           | 202.7       | 200.0        | 0.99        |
| Site: BGU05 [BGU05 Kent St / Sydney Harbour Bridge (SHB) On-ramp]        |          |           |             |                  |                                    |     |           |                |             |              |             |
| South: Kent St (S)   |          |           |             |                  |                                    |     |           |                |             |              |             |
| P1   | Full     | 349       | 32.7        | LOS D            | 0.7                                | 0.7 | 0.88      | 0.88           | 49.4        | 20.0         | 0.41        |
| All Pedestrians  |          | 349       | 32.7        | LOS D            | 0.7                                | 0.7 | 0.88      | 0.88           | 49.4        | 20.0         | 0.41        |

Level of Service (LOS) Method: SIDRA Pedestrian LOS Method (Based on Average Delay)  
 Pedestrian movement LOS values are based on average delay per pedestrian movement.  
 Intersection LOS value for Pedestrians is based on average delay for all pedestrian movements.

# MOVEMENT SUMMARY

Site: BGU06 [BGU06 Hickson Rd / Napoleon St / Sussex St  
(Site Folder: Block 1 - 2023 AM Peak)]

Output produced by SIDRA INTERSECTION Version: 9.1.1.200

Network: BGU-N2 [BGU  
Network 3 (Network Folder:  
Block 1 Network - 2023 AM  
Peak)]

TCS 4625

Site Category: (None)

Signals - EQUISAT (Fixed-Time/SCATS) Isolated Cycle Time = 71 seconds (Site User-Given Phase Times)

| Vehicle Movement Performance |      |           |                       |      |                       |      |           |             |                  |                   |               |           |                |                     |                  |
|------------------------------|------|-----------|-----------------------|------|-----------------------|------|-----------|-------------|------------------|-------------------|---------------|-----------|----------------|---------------------|------------------|
| Mov ID                       | Turn | Mov Class | Demand Flows          |      | Arrival Flows         |      | Deg. Satn | Aver. Delay | Level of Service | 95% Back Of Queue |               | Prop. Que | Eff. Stop Rate | Aver. No. of Cycles | Aver. Speed km/h |
|                              |      |           | [ Total HV ]<br>veh/h | %    | [ Total HV ]<br>veh/h | %    |           |             |                  | [ Veh. veh        | [ Dist ]<br>m |           |                |                     |                  |
| South: Sussex St (S)         |      |           |                       |      |                       |      |           |             |                  |                   |               |           |                |                     |                  |
| 2                            | T1   | All MCs   | 324                   | 9.1  | 324                   | 9.1  | 0.348     | 10.7        | LOS A            | 6.6               | 49.7          | 0.62      | 0.54           | 0.62                | 24.8             |
| 3                            | R2   | All MCs   | 122                   | 2.6  | 122                   | 2.6  | *0.309    | 18.8        | LOS B            | 2.8               | 20.4          | 0.80      | 0.73           | 0.80                | 22.1             |
| Approach                     |      |           | 446                   | 7.3  | 446                   | 7.3  | 0.348     | 12.9        | LOS A            | 6.6               | 49.7          | 0.67      | 0.59           | 0.67                | 23.8             |
| East: Napoleon St (E)        |      |           |                       |      |                       |      |           |             |                  |                   |               |           |                |                     |                  |
| 4                            | L2   | All MCs   | 143                   | 13.2 | 143                   | 13.2 | 0.240     | 20.6        | LOS B            | 3.5               | 27.2          | 0.73      | 0.72           | 0.73                | 15.9             |
| 6                            | R2   | All MCs   | 184                   | 14.9 | 184                   | 14.9 | *0.511    | 30.3        | LOS C            | 5.8               | 45.9          | 0.92      | 0.79           | 0.92                | 15.3             |
| Approach                     |      |           | 327                   | 14.1 | 327                   | 14.1 | 0.511     | 26.1        | LOS B            | 5.8               | 45.9          | 0.84      | 0.76           | 0.84                | 15.5             |
| North: Hickson Rd (N)        |      |           |                       |      |                       |      |           |             |                  |                   |               |           |                |                     |                  |
| 7                            | L2   | All MCs   | 93                    | 10.2 | 93                    | 10.2 | 0.179     | 23.1        | LOS B            | 2.4               | 18.1          | 0.77      | 0.71           | 0.77                | 17.6             |
| 8                            | T1   | All MCs   | 203                   | 18.1 | 203                   | 18.1 | *0.336    | 18.0        | LOS B            | 5.2               | 41.8          | 0.77      | 0.64           | 0.77                | 11.5             |
| Approach                     |      |           | 296                   | 15.7 | 296                   | 15.7 | 0.336     | 19.6        | LOS B            | 5.2               | 41.8          | 0.77      | 0.66           | 0.77                | 14.2             |
| West: Car Park Access (W)    |      |           |                       |      |                       |      |           |             |                  |                   |               |           |                |                     |                  |
| 10                           | L2   | All MCs   | 1                     | 0.0  | 1                     | 0.0  | 0.040     | 43.6        | LOS D            | 0.0               | 0.3           | 1.00      | 0.57           | 1.00                | 5.4              |
| 11                           | T1   | All MCs   | 4                     | 0.0  | 4                     | 0.0  | *0.193    | 45.1        | LOS D            | 0.2               | 1.5           | 1.00      | 0.63           | 1.00                | 8.5              |
| 12                           | R2   | All MCs   | 1                     | 0.0  | 1                     | 0.0  | 0.193     | 45.1        | LOS D            | 0.2               | 1.5           | 1.00      | 0.63           | 1.00                | 2.3              |
| Approach                     |      |           | 6                     | 0.0  | 6                     | 0.0  | 0.193     | 44.8        | LOS D            | 0.2               | 1.5           | 1.00      | 0.62           | 1.00                | 7.1              |
| All Vehicles                 |      |           | 1076                  | 11.6 | 1076                  | 11.6 | 0.511     | 18.9        | LOS B            | 6.6               | 49.7          | 0.75      | 0.66           | 0.75                | 18.2             |

Site Level of Service (LOS) Method: Delay (RTA NSW). Site LOS Method is specified in the Network Data dialog (Override Site Data tab).

Vehicle movement LOS values are based on average delay per movement.

Intersection and Approach LOS values are based on average delay for all vehicle movements.

Delay Model: SIDRA Standard (Control Delay: Geometric Delay is included).

Queue Model: SIDRA queue estimation methods are used for Back of Queue and Queue at Start of Green.

Gap-Acceptance Capacity Formula: SIDRA Standard (Akçelik M3D).

HV (%) values are calculated for All Movement Classes of All Heavy Vehicle Model Designation.

Arrival Flows used in performance calculations are adjusted to include any Initial Queued Demand and Upstream Capacity Constraint effects.

\* Critical Movement (Signal Timing)

| Pedestrian Movement Performance |          |           |             |                  |                       |        |           |                |             |              |             |
|---------------------------------|----------|-----------|-------------|------------------|-----------------------|--------|-----------|----------------|-------------|--------------|-------------|
| Mov ID                          | Crossing | Dem. Flow | Aver. Delay | Level of Service | AVERAGE BACK OF QUEUE |        | Prop. Que | Eff. Stop Rate | Travel Time | Travel Dist. | Aver. Speed |
|                                 |          | ped/h     | sec         |                  | [ Ped                 | Dist ] |           |                | sec         | m            | m/sec       |
|                                 |          |           |             |                  | ped                   | m      |           |                |             |              |             |
| South: Sussex St (S)            |          |           |             |                  |                       |        |           |                |             |              |             |
| P1                              | Full     | 79        | 23.0        | LOS C            | 0.1                   | 0.1    | 0.81      | 0.81           | 39.6        | 20.0         | 0.50        |
| East: Napoleon St (E)           |          |           |             |                  |                       |        |           |                |             |              |             |
| P2                              | Full     | 227       | 23.1        | LOS C            | 0.4                   | 0.4    | 0.81      | 0.81           | 39.8        | 20.0         | 0.50        |
| North: Hickson Rd (N)           |          |           |             |                  |                       |        |           |                |             |              |             |
| P3                              | Full     | 85        | 23.0        | LOS C            | 0.1                   | 0.1    | 0.81      | 0.81           | 39.6        | 20.0         | 0.50        |
| West: Car Park Access (W)       |          |           |             |                  |                       |        |           |                |             |              |             |
| P4                              | Full     | 181       | 28.2        | LOS C            | 0.3                   | 0.3    | 0.89      | 0.89           | 44.8        | 20.0         | 0.45        |
| All Pedestrians                 |          | 573       | 24.7        | LOS C            | 0.4                   | 0.4    | 0.84      | 0.84           | 41.3        | 20.0         | 0.48        |

Level of Service (LOS) Method: SIDRA Pedestrian LOS Method (Based on Average Delay)

Pedestrian movement LOS values are based on average delay per pedestrian movement.

Intersection LOS value for Pedestrians is based on average delay for all pedestrian movements.

**SIDRA INTERSECTION 9.1 | Copyright © 2000-2022 Akcelik and Associates Pty Ltd | sidrasolutions.com**

Organisation: AECOM AUSTRALIA PTY LTD | Licence: NETWORK / Enterprise Level 1 | Processed: Friday, 14 July 2023 3:11:17 PM

Project: C:\Users\YeungMA\AECOM\ANZ-NAC-Sydney Metro-Sydney Metro C&SW Operational Monitoring - General\400\_Technical\432\_Traffic Analysis\SIDRA Modelling\01 Models (Geometry Only)\Block 1\Rev1\_Review\04 SM C&SW\_BGU (Block 1)\_PS.sip9

# MOVEMENT SUMMARY

Site: BGU07 [BGU07 Margaret St / Kent St / Napoleon St (Site Folder: Block 1 - 2023 AM Peak)]

Output produced by SIDRA INTERSECTION Version: 9.1.3.210

Network: BGU-N2 [BGU Network 2 (Network Folder: Block 1 Network - 2023 AM Peak)]

TCS 308

Site Category: (None)

Signals - EQUISAT (Fixed-Time/SCATS) Coordinated Cycle Time = 85 seconds (Network Site User-Given Phase Times)

| Vehicle Movement Performance |      |           |              |      |               |      |           |             |                  |                   |        |           |                |                     |             |
|------------------------------|------|-----------|--------------|------|---------------|------|-----------|-------------|------------------|-------------------|--------|-----------|----------------|---------------------|-------------|
| Mov ID                       | Turn | Mov Class | Demand Flows |      | Arrival Flows |      | Deg. Satn | Aver. Delay | Level of Service | 95% Back Of Queue |        | Prop. Que | Eff. Stop Rate | Aver. No. of Cycles | Aver. Speed |
|                              |      |           | [ Total HV ] | %    | [ Total HV ]  | %    | v/c       | sec         |                  | [ Veh. veh        | Dist ] |           |                |                     | km/h        |
| South: Kent St (S)           |      |           |              |      |               |      |           |             |                  |                   |        |           |                |                     |             |
| 1a                           | L1   | All MCs   | 102          | 15.5 | 102           | 15.5 | *0.496    | 31.1        | LOS C            | 11.3              | 86.3   | 0.77      | 0.70           | 0.77                | 18.7        |
| 2                            | T1   | All MCs   | 566          | 7.6  | 566           | 7.6  | 0.496     | 21.3        | LOS B            | 11.3              | 86.3   | 0.84      | 0.71           | 0.84                | 7.7         |
| 3                            | R2   | All MCs   | 38           | 0.0  | 38            | 0.0  | 0.496     | 57.7        | LOS E            | 7.6               | 57.1   | 0.88      | 0.75           | 0.88                | 7.1         |
| Approach                     |      |           | 706          | 8.3  | 706           | 8.3  | 0.496     | 24.7        | LOS B            | 11.3              | 86.3   | 0.83      | 0.71           | 0.83                | 9.5         |
| East: Margaret St (E)        |      |           |              |      |               |      |           |             |                  |                   |        |           |                |                     |             |
| 4                            | L2   | All MCs   | 67           | 3.1  | 67            | 3.1  | 0.266     | 43.7        | LOS D            | 2.8               | 20.2   | 1.00      | 0.77           | 1.00                | 7.3         |
| 6a                           | R1   | All MCs   | 218          | 16.4 | 218           | 16.4 | 0.778     | 39.7        | LOS C            | 8.4               | 65.3   | 1.00      | 0.95           | 1.11                | 12.3        |
| 6                            | R2   | All MCs   | 82           | 2.6  | 82            | 2.6  | *0.778    | 41.7        | LOS C            | 8.4               | 65.3   | 1.00      | 0.95           | 1.11                | 5.1         |
| Approach                     |      |           | 367          | 10.9 | 367           | 10.9 | 0.778     | 40.9        | LOS C            | 8.4               | 65.3   | 1.00      | 0.92           | 1.09                | 10.0        |
| North: Kent St (N)           |      |           |              |      |               |      |           |             |                  |                   |        |           |                |                     |             |
| 7                            | L2   | All MCs   | 45           | 0.0  | 45            | 0.0  | 0.248     | 32.4        | LOS C            | 3.4               | 25.6   | 0.67      | 0.60           | 0.67                | 19.9        |
| 8                            | T1   | All MCs   | 149          | 7.0  | 149           | 7.0  | 0.248     | 24.7        | LOS B            | 3.4               | 25.6   | 0.82      | 0.66           | 0.82                | 17.5        |
| 9b                           | R3   | All MCs   | 74           | 4.3  | 74            | 4.3  | 0.248     | 12.0        | LOS A            | 0.9               | 6.6    | 0.30      | 0.60           | 0.30                | 28.5        |
| Approach                     |      |           | 268          | 5.1  | 268           | 5.1  | 0.248     | 22.5        | LOS B            | 3.4               | 25.6   | 0.65      | 0.64           | 0.65                | 20.5        |
| NorthWest: Napoleon St (NW)  |      |           |              |      |               |      |           |             |                  |                   |        |           |                |                     |             |
| 27b                          | L3   | All MCs   | 126          | 5.0  | 126           | 5.0  | 0.314     | 10.6        | LOS A            | 3.0               | 22.3   | 0.59      | 0.67           | 0.59                | 23.7        |
| 27a                          | L1   | All MCs   | 48           | 10.9 | 48            | 10.9 | 0.314     | 20.9        | LOS B            | 3.0               | 22.3   | 0.59      | 0.67           | 0.59                | 23.7        |
| Approach                     |      |           | 175          | 6.6  | 175           | 6.6  | 0.314     | 13.4        | LOS A            | 3.0               | 22.3   | 0.59      | 0.67           | 0.59                | 23.7        |
| All Vehicles                 |      |           | 1517         | 8.2  | 1517          | 8.2  | 0.778     | 26.9        | LOS B            | 11.3              | 86.3   | 0.81      | 0.74           | 0.83                | 13.2        |

Site Level of Service (LOS) Method: Delay (RTA NSW). Site LOS Method is specified in the Network Data dialog (Override Site Data tab).

Vehicle movement LOS values are based on average delay per movement.

Intersection and Approach LOS values are based on average delay for all vehicle movements.

Delay Model: SIDRA Standard (Control Delay: Geometric Delay is included).

Queue Model: SIDRA queue estimation methods are used for Back of Queue and Queue at Start of Green.

Gap-Acceptance Capacity Formula: SIDRA Standard (Akçelik M3D).

HV (%) values are calculated for All Movement Classes of All Heavy Vehicle Model Designation.

Arrival Flows used in performance calculations are adjusted to include any Initial Queued Demand and Upstream Capacity Constraint effects.

\* Critical Movement (Signal Timing)

| Pedestrian Movement Performance |          |           |             |                  |                       |        |           |                |             |              |             |
|---------------------------------|----------|-----------|-------------|------------------|-----------------------|--------|-----------|----------------|-------------|--------------|-------------|
| Mov ID                          | Crossing | Dem. Flow | Aver. Delay | Level of Service | AVERAGE BACK OF QUEUE |        | Prop. Que | Eff. Stop Rate | Travel Time | Travel Dist. | Aver. Speed |
|                                 |          | ped/h     | sec         |                  | [ Ped                 | Dist ] |           |                | sec         | m            | m/sec       |
|                                 |          |           |             |                  | ped                   | m      |           |                |             |              |             |
| South: Kent St (S)              |          |           |             |                  |                       |        |           |                |             |              |             |
| P1                              | Full     | 1017      | 31.0        | LOS D            | 2.1                   | 2.1    | 0.87      | 0.87           | 47.6        | 20.0         | 0.42        |
| East: Margaret St (E)           |          |           |             |                  |                       |        |           |                |             |              |             |
| P2                              | Full     | 105       | 34.1        | LOS D            | 0.2                   | 0.2    | 0.90      | 0.90           | 50.8        | 20.0         | 0.39        |
| North: Kent St (N)              |          |           |             |                  |                       |        |           |                |             |              |             |
| P3                              | Full     | 257       | 29.1        | LOS C            | 0.5                   | 0.5    | 0.83      | 0.83           | 45.8        | 20.0         | 0.44        |
| NorthWest: Napoleon St (NW)     |          |           |             |                  |                       |        |           |                |             |              |             |
| P7                              | Full     | 901       | 29.9        | LOS C            | 1.9                   | 1.9    | 0.86      | 0.86           | 196.6       | 200.0        | 1.02        |
| All Pedestrians                 |          | 2280      | 30.5        | LOS D            | 2.1                   | 2.1    | 0.86      | 0.86           | 106.4       | 91.1         | 0.86        |

Level of Service (LOS) Method: SIDRA Pedestrian LOS Method (Based on Average Delay)  
 Pedestrian movement LOS values are based on average delay per pedestrian movement.  
 Intersection LOS value for Pedestrians is based on average delay for all pedestrian movements.

# MOVEMENT SUMMARY

Site: BGU08 [BGU08 Margaret St / Clarence St (Site Folder: Block 1 - 2023 AM Peak)]

Output produced by SIDRA INTERSECTION Version: 9.1.3.210

Network: BGU-N2 [BGU Network 2 (Network Folder: Block 1 Network - 2023 AM Peak)]

TCS 319

Site Category: NA

Signals - EQUISAT (Fixed-Time/SCATS) Coordinated Cycle Time = 85 seconds (Network Site User-Given Phase Times)

| Vehicle Movement Performance |      |           |              |      |               |      |           |             |                  |                   |        |           |                |                     |             |
|------------------------------|------|-----------|--------------|------|---------------|------|-----------|-------------|------------------|-------------------|--------|-----------|----------------|---------------------|-------------|
| Mov ID                       | Turn | Mov Class | Demand Flows |      | Arrival Flows |      | Deg. Satn | Aver. Delay | Level of Service | 95% Back Of Queue |        | Prop. Que | Eff. Stop Rate | Aver. No. of Cycles | Aver. Speed |
|                              |      |           | [ Total HV ] | %    | [ Total HV ]  | %    |           |             |                  | [ Veh. veh        | Dist ] |           |                |                     |             |
| South: Clarence St (S)       |      |           |              |      |               |      |           |             |                  |                   |        |           |                |                     |             |
| 1                            | L2   | All MCs   | 51           | 12.5 | 51            | 12.5 | 0.518     | 42.3        | LOS C            | 9.2               | 67.7   | 0.90      | 0.76           | 0.90                | 13.3        |
| 2                            | T1   | All MCs   | 568          | 34.8 | 568           | 34.8 | *0.518    | 24.6        | LOS B            | 9.2               | 67.7   | 0.84      | 0.71           | 0.84                | 17.5        |
| 3                            | R2   | All MCs   | 16           | 0.0  | 16            | 0.0  | 0.518     | 33.8        | LOS C            | 7.0               | 50.8   | 0.88      | 0.75           | 0.88                | 14.4        |
| Approach                     |      |           | 635          | 32.2 | 635           | 32.2 | 0.518     | 26.2        | LOS B            | 9.2               | 67.7   | 0.85      | 0.71           | 0.85                | 17.1        |
| East: Margaret St (E)        |      |           |              |      |               |      |           |             |                  |                   |        |           |                |                     |             |
| 5                            | T1   | All MCs   | 343          | 9.8  | 343           | 9.8  | 0.481     | 14.4        | LOS A            | 7.1               | 53.7   | 0.72      | 0.63           | 0.72                | 10.8        |
| 6                            | R2   | All MCs   | 79           | 70.7 | 79            | 70.7 | *0.481    | 19.8        | LOS B            | 4.2               | 39.6   | 0.81      | 0.72           | 0.81                | 14.4        |
| Approach                     |      |           | 422          | 21.2 | 422           | 21.2 | 0.481     | 15.4        | LOS B            | 7.1               | 53.7   | 0.73      | 0.65           | 0.73                | 11.7        |
| West: Margaret St (W)        |      |           |              |      |               |      |           |             |                  |                   |        |           |                |                     |             |
| 10                           | L2   | All MCs   | 75           | 11.3 | 75            | 11.3 | *0.686    | 51.7        | LOS D            | 6.6               | 50.8   | 1.00      | 0.88           | 1.08                | 7.4         |
| 11                           | T1   | All MCs   | 77           | 12.3 | 77            | 12.3 | 0.686     | 37.9        | LOS C            | 6.6               | 50.8   | 1.00      | 0.88           | 1.08                | 4.1         |
| Approach                     |      |           | 152          | 11.8 | 152           | 11.8 | 0.686     | 44.7        | LOS D            | 6.6               | 50.8   | 1.00      | 0.88           | 1.08                | 5.8         |
| All Vehicles                 |      |           | 1208         | 25.8 | 1208          | 25.8 | 0.686     | 24.8        | LOS B            | 9.2               | 67.7   | 0.83      | 0.71           | 0.84                | 14.1        |

Site Level of Service (LOS) Method: Delay (RTA NSW). Site LOS Method is specified in the Network Data dialog (Override Site Data tab).

Vehicle movement LOS values are based on average delay per movement.

Intersection and Approach LOS values are based on average delay for all vehicle movements.

Delay Model: SIDRA Standard (Control Delay: Geometric Delay is included).

Queue Model: SIDRA queue estimation methods are used for Back of Queue and Queue at Start of Green.

Gap-Acceptance Capacity Formula: SIDRA Standard (Akçelik M3D).

HV (%) values are calculated for All Movement Classes of All Heavy Vehicle Model Designation.

Arrival Flows used in performance calculations are adjusted to include any Initial Queued Demand and Upstream Capacity Constraint effects.

\* Critical Movement (Signal Timing)



| Pedestrian Movement Performance |          |           |             |                  |                       |        |           |                |             |              |             |
|---------------------------------|----------|-----------|-------------|------------------|-----------------------|--------|-----------|----------------|-------------|--------------|-------------|
| Mov ID                          | Crossing | Dem. Flow | Aver. Delay | Level of Service | AVERAGE BACK OF QUEUE |        | Prop. Que | Eff. Stop Rate | Travel Time | Travel Dist. | Aver. Speed |
|                                 |          | ped/h     | sec         |                  | [ Ped                 | Dist ] |           |                | sec         | m            | m/sec       |
|                                 |          |           |             |                  | ped                   | m      |           |                |             |              |             |
| South: Clarence St (S)          |          |           |             |                  |                       |        |           |                |             |              |             |
| P1                              | Full     | 1484      | 37.2        | LOS D            | 3.5                   | 3.5    | 0.97      | 0.97           | 53.8        | 20.0         | 0.37        |
| East: Margaret St (E)           |          |           |             |                  |                       |        |           |                |             |              |             |
| P2                              | Full     | 187       | 35.2        | LOS D            | 0.4                   | 0.4    | 0.91      | 0.91           | 51.8        | 20.0         | 0.39        |
| North: Clarence St (N)          |          |           |             |                  |                       |        |           |                |             |              |             |
| P3                              | Full     | 574       | 33.9        | LOS D            | 1.3                   | 1.3    | 0.90      | 0.90           | 50.6        | 20.0         | 0.40        |
| West: Margaret St (W)           |          |           |             |                  |                       |        |           |                |             |              |             |
| P4                              | Full     | 879       | 31.7        | LOS D            | 1.9                   | 1.9    | 0.88      | 0.88           | 48.3        | 20.0         | 0.41        |
| All Pedestrians                 |          | 3124      | 34.9        | LOS D            | 3.5                   | 3.5    | 0.93      | 0.93           | 51.6        | 20.0         | 0.39        |

Level of Service (LOS) Method: SIDRA Pedestrian LOS Method (Based on Average Delay)

Pedestrian movement LOS values are based on average delay per pedestrian movement.

Intersection LOS value for Pedestrians is based on average delay for all pedestrian movements.

**SIDRA INTERSECTION 9.1 | Copyright © 2000-2022 Akcelik and Associates Pty Ltd | sidrasolutions.com**

Organisation: AECOM AUSTRALIA PTY LTD | Licence: NETWORK / Enterprise Level 1 | Processed: Monday, 17 July 2023 11:58:28 AM

Project: C:\Users\YeungMA\AECOM\ANZ-NAC-Sydney Metro-Sydney Metro C&SW Operational Monitoring - General\400\_Technical\432\_Traffic Analysis\SIDRA Modelling\01 Models (Geometry Only)\Block 1\Rev1\_Review\04 SM C&SW\_BGU (Block 1)\_PS.sip9

# MOVEMENT SUMMARY

Site: BGU09 [BGU09 Margaret St / York St (Site Folder: Block 1 - 2023 AM Peak)]

Output produced by SIDRA INTERSECTION Version: 9.1.3.210

Network: BGU-N2 [BGU Network 2 (Network Folder: Block 1 Network - 2023 AM Peak)]

TCS 3042

Site Category: NA

Signals - EQUISAT (Fixed-Time/SCATS) Isolated Cycle Time = 90 seconds (Site User-Given Phase Times)

| Vehicle Movement Performance |      |           |                       |      |                       |      |           |             |                  |                   |               |           |                |                     |             |
|------------------------------|------|-----------|-----------------------|------|-----------------------|------|-----------|-------------|------------------|-------------------|---------------|-----------|----------------|---------------------|-------------|
| Mov ID                       | Turn | Mov Class | Demand Flows          |      | Arrival Flows         |      | Deg. Satn | Aver. Delay | Level of Service | 95% Back Of Queue |               | Prop. Que | Eff. Stop Rate | Aver. No. of Cycles | Aver. Speed |
|                              |      |           | [ Total HV ]<br>veh/h | %    | [ Total HV ]<br>veh/h | %    |           |             |                  | [ Veh. veh        | [ Dist ]<br>m |           |                |                     |             |
| East: Margaret St (E)        |      |           |                       |      |                       |      |           |             |                  |                   |               |           |                |                     |             |
| 4                            | L2   | All MCs   | 54                    | 5.9  | 54                    | 5.9  | 0.248     | 41.9        | LOS C            | 2.4               | 18.4          | 0.92      | 0.74           | 0.92                | 13.1        |
| 5                            | T1   | All MCs   | 89                    | 61.2 | 89                    | 61.2 | 0.248     | 27.8        | LOS B            | 2.9               | 31.1          | 0.82      | 0.66           | 0.82                | 8.0         |
| Approach                     |      |           | 143                   | 40.4 | 143                   | 40.4 | 0.248     | 33.1        | LOS C            | 2.9               | 31.1          | 0.86      | 0.69           | 0.86                | 10.6        |
| North: York St (N)           |      |           |                       |      |                       |      |           |             |                  |                   |               |           |                |                     |             |
| 7                            | L2   | All MCs   | 1                     | 0.0  | 1                     | 0.0  | 0.000     | 16.1        | LOS B            | 0.0               | 0.1           | 0.57      | 0.48           | 0.57                | 15.4        |
| 8                            | T1   | All MCs   | 814                   | 28.5 | 814                   | 28.5 | 0.309     | 10.5        | LOS A            | 6.1               | 53.1          | 0.55      | 0.47           | 0.55                | 26.7        |
| 9                            | R2   | All MCs   | 333                   | 10.4 | 333                   | 10.4 | * 0.437   | 18.3        | LOS B            | 9.1               | 69.2          | 0.66      | 0.76           | 0.66                | 11.3        |
| Approach                     |      |           | 1147                  | 23.2 | 1147                  | 23.2 | 0.437     | 12.8        | LOS A            | 9.1               | 69.2          | 0.58      | 0.56           | 0.58                | 22.9        |
| West: Margaret St (W)        |      |           |                       |      |                       |      |           |             |                  |                   |               |           |                |                     |             |
| 12                           | R2   | All MCs   | 84                    | 10.0 | 84                    | 10.0 | * 0.455   | 45.1        | LOS D            | 3.6               | 27.7          | 0.97      | 0.77           | 0.97                | 11.2        |
| Approach                     |      |           | 84                    | 10.0 | 84                    | 10.0 | 0.455     | 45.1        | LOS D            | 3.6               | 27.7          | 0.97      | 0.77           | 0.97                | 11.2        |
| All Vehicles                 |      |           | 1375                  | 24.2 | 1375                  | 24.2 | 0.455     | 16.9        | LOS B            | 9.1               | 69.2          | 0.63      | 0.58           | 0.63                | 19.7        |

Site Level of Service (LOS) Method: Delay (RTA NSW). Site LOS Method is specified in the Network Data dialog (Override Site Data tab).

Vehicle movement LOS values are based on average delay per movement.

Intersection and Approach LOS values are based on average delay for all vehicle movements.

Delay Model: SIDRA Standard (Control Delay: Geometric Delay is included).

Queue Model: SIDRA queue estimation methods are used for Back of Queue and Queue at Start of Green.

Gap-Acceptance Capacity Formula: SIDRA Standard (Akçelik M3D).

HV (%) values are calculated for All Movement Classes of All Heavy Vehicle Model Designation.

Arrival Flows used in performance calculations are adjusted to include any Initial Queued Demand and Upstream Capacity Constraint effects.

\* Critical Movement (Signal Timing)

| Pedestrian Movement Performance |          |           |             |                  |                       |        |           |                |             |              |             |
|---------------------------------|----------|-----------|-------------|------------------|-----------------------|--------|-----------|----------------|-------------|--------------|-------------|
| Mov ID                          | Crossing | Dem. Flow | Aver. Delay | Level of Service | AVERAGE BACK OF QUEUE |        | Prop. Que | Eff. Stop Rate | Travel Time | Travel Dist. | Aver. Speed |
|                                 |          | ped/h     | sec         |                  | [ Ped                 | Dist ] |           |                | sec         | m            | m/sec       |
|                                 |          |           |             |                  | ped                   | m      |           |                |             |              |             |
| South: York St (S)              |          |           |             |                  |                       |        |           |                |             |              |             |
| P1                              | Full     | 1782      | 35.6        | LOS D            | 4.2                   | 4.2    | 0.92      | 0.92           | 52.2        | 20.0         | 0.38        |
| East: Margaret St (E)           |          |           |             |                  |                       |        |           |                |             |              |             |
| P2                              | Full     | 2375      | 36.6        | LOS D            | 5.8                   | 5.8    | 0.95      | 0.95           | 53.2        | 20.0         | 0.38        |
| North: York St (N)              |          |           |             |                  |                       |        |           |                |             |              |             |
| P3                              | Full     | 1428      | 33.2        | LOS D            | 3.2                   | 3.2    | 0.89      | 0.89           | 49.9        | 20.0         | 0.40        |
| West: Margaret St (W)           |          |           |             |                  |                       |        |           |                |             |              |             |
| P4                              | Full     | 1254      | 37.5        | LOS D            | 3.0                   | 3.0    | 0.94      | 0.94           | 54.2        | 20.0         | 0.37        |
| All Pedestrians                 |          | 6839      | 35.8        | LOS D            | 5.8                   | 5.8    | 0.93      | 0.93           | 52.4        | 20.0         | 0.38        |

Level of Service (LOS) Method: SIDRA Pedestrian LOS Method (Based on Average Delay)

Pedestrian movement LOS values are based on average delay per pedestrian movement.

Intersection LOS value for Pedestrians is based on average delay for all pedestrian movements.

**SIDRA INTERSECTION 9.1 | Copyright © 2000-2022 Akcelik and Associates Pty Ltd | sidrasolutions.com**

Organisation: AECOM AUSTRALIA PTY LTD | Licence: NETWORK / Enterprise Level 1 | Processed: Monday, 17 July 2023 11:58:28 AM

Project: C:\Users\YeungMA\AECOM\ANZ-NAC-Sydney Metro-Sydney Metro C&SW Operational Monitoring - General\400\_Technical\432\_Traffic Analysis\SIDRA Modelling\01 Models (Geometry Only)\Block 1\Rev1\_Review\04 SM C&SW\_BGU (Block 1)\_PS.sip9

# MOVEMENT SUMMARY

 Site: BGU10 [BGU10 Pedestrian Mid-block Crossing at Sussex St under Exchange PI (Site Folder: Block 1 - 2023 AM Peak)]

 Network: BGU-N2 [BGU Network 3 (Network Folder: Block 1 Network - 2023 AM Peak)]

Output produced by SIDRA INTERSECTION Version: 9.1.1.200

TCS 3939 (?)

Site Category: (None)

Pedestrian Crossing (Signalised) - EQUISAT (Fixed-Time/SCATS) Isolated Cycle Time = 70 seconds (Site User-Given Phase Times)

| Vehicle Movement Performance |      |           |              |      |               |      |           |             |                  |                   |          |           |                |                     |             |
|------------------------------|------|-----------|--------------|------|---------------|------|-----------|-------------|------------------|-------------------|----------|-----------|----------------|---------------------|-------------|
| Mov ID                       | Turn | Mov Class | Demand Flows |      | Arrival Flows |      | Deg. Satn | Aver. Delay | Level of Service | 95% Back Of Queue |          | Prop. Que | Eff. Stop Rate | Aver. No. of Cycles | Aver. Speed |
|                              |      |           | [ Total HV ] | %    | [ Total HV ]  | %    |           |             |                  | [ Veh. veh        | Dist ] m |           |                |                     |             |
| South: Sussex St (S)         |      |           |              |      |               |      |           |             |                  |                   |          |           |                |                     |             |
| 2                            | T1   | All MCs   | 475          | 6.7  | 475           | 6.7  | *0.175    | 2.8         | LOS A            | 2.4               | 17.5     | 0.31      | 0.27           | 0.31                | 33.1        |
| Approach                     |      |           | 475          | 6.7  | 475           | 6.7  | 0.175     | 2.8         | LOS A            | 2.4               | 17.5     | 0.31      | 0.27           | 0.31                | 33.1        |
| North: Sussex St (N)         |      |           |              |      |               |      |           |             |                  |                   |          |           |                |                     |             |
| 8                            | T1   | All MCs   | 321          | 16.7 | 321           | 16.7 | 0.129     | 2.7         | LOS A            | 1.5               | 12.3     | 0.30      | 0.25           | 0.30                | 32.2        |
| Approach                     |      |           | 321          | 16.7 | 321           | 16.7 | 0.129     | 2.7         | LOS A            | 1.5               | 12.3     | 0.30      | 0.25           | 0.30                | 32.2        |
| All Vehicles                 |      |           | 796          | 10.7 | 796           | 10.7 | 0.175     | 2.8         | LOS A            | 2.4               | 17.5     | 0.31      | 0.26           | 0.31                | 32.8        |

Site Level of Service (LOS) Method: Delay (RTA NSW). Site LOS Method is specified in the Network Data dialog (Override Site Data tab).

Vehicle movement LOS values are based on average delay per movement.

Intersection and Approach LOS values are based on average delay for all vehicle movements.

Delay Model: SIDRA Standard (Control Delay: Geometric Delay is included).

Queue Model: SIDRA queue estimation methods are used for Back of Queue and Queue at Start of Green.

Gap-Acceptance Capacity Formula: SIDRA Standard (Akçelik M3D).

HV (%) values are calculated for All Movement Classes of All Heavy Vehicle Model Designation.

Arrival Flows used in performance calculations are adjusted to include any Initial Queued Demand and Upstream Capacity Constraint effects.

\* Critical Movement (Signal Timing)

| Pedestrian Movement Performance |          |           |             |                  |                       |        |           |                |             |              |             |
|---------------------------------|----------|-----------|-------------|------------------|-----------------------|--------|-----------|----------------|-------------|--------------|-------------|
| Mov ID                          | Crossing | Dem. Flow | Aver. Delay | Level of Service | AVERAGE BACK OF QUEUE |        | Prop. Que | Eff. Stop Rate | Travel Time | Travel Dist. | Aver. Speed |
|                                 |          | ped/h     | sec         |                  | [ Ped                 | Dist ] |           |                | sec         | m            | m/sec       |
|                                 |          |           |             |                  | ped                   | m      |           |                |             |              |             |
| South: Sussex St (S)            |          |           |             |                  |                       |        |           |                |             |              |             |
| P1                              | Full     | 493       | 24.5        | LOS C            | 0.8                   | 0.8    | 0.85      | 0.85           | 41.2        | 20.0         | 0.49        |
| All Pedestrians                 |          | 493       | 24.5        | LOS C            | 0.8                   | 0.8    | 0.85      | 0.85           | 41.2        | 20.0         | 0.49        |

Level of Service (LOS) Method: SIDRA Pedestrian LOS Method (Based on Average Delay)  
 Pedestrian movement LOS values are based on average delay per pedestrian movement.  
 Intersection LOS value for Pedestrians is based on average delay for all pedestrian movements.

---

**SIDRA INTERSECTION 9.1 | Copyright © 2000-2022 Akcelik and Associates Pty Ltd | sidrasolutions.com**  
 Organisation: AECOM AUSTRALIA PTY LTD | Licence: NETWORK / Enterprise Level 1 | Processed: Friday, 14 July 2023 3:11:17 PM  
 Project: C:\Users\YeungM\AECOM\ANZ-NAC-Sydney Metro-Sydney Metro C&SW Operational Monitoring - General\400\_Technical\432\_Traffic Analysis\SIDRA Modelling\01 Models (Geometry Only)\Block 1\Rev1\\_Review\04 SM C&SW\_BGU (Block 1)\_PS.sip9

# MOVEMENT SUMMARY

 Site: BGU11 [BGU11 Pedestrian Mid-block Crossing at Kent St near Margaret St (Site Folder: Block 1 - 2023 AM Peak)]

Output produced by SIDRA INTERSECTION Version: 9.1.1.200

 Network: BGU-N2 [BGU Network 3 (Network Folder: Block 1 Network - 2023 AM Peak)]

TCS 4109

Site Category: (None)

Pedestrian Crossing (Signalised) - EQUISAT (Fixed-Time/SCATS) Isolated Cycle Time = 45 seconds (Site User-Given Phase Times)

| Vehicle Movement Performance |      |           |              |     |               |     |           |             |                  |                   |          |           |                |                     |             |
|------------------------------|------|-----------|--------------|-----|---------------|-----|-----------|-------------|------------------|-------------------|----------|-----------|----------------|---------------------|-------------|
| Mov ID                       | Turn | Mov Class | Demand Flows |     | Arrival Flows |     | Deg. Satn | Aver. Delay | Level of Service | 95% Back Of Queue |          | Prop. Que | Eff. Stop Rate | Aver. No. of Cycles | Aver. Speed |
|                              |      |           | [ Total HV ] | %   | [ Total HV ]  | %   |           |             |                  | [ Veh. veh        | Dist ] m |           |                |                     |             |
| South: Kent St (S)           |      |           |              |     |               |     |           |             |                  |                   |          |           |                |                     |             |
| 2                            | T1   | All MCs   | 775          | 8.6 | 775           | 8.6 | *0.442    | 9.9         | LOS A            | 5.3               | 40.4     | 0.73      | 0.62           | 0.73                | 22.1        |
| Approach                     |      |           | 775          | 8.6 | 775           | 8.6 | 0.442     | 9.9         | LOS A            | 5.3               | 40.4     | 0.73      | 0.62           | 0.73                | 22.1        |
| North: Kent St (N)           |      |           |              |     |               |     |           |             |                  |                   |          |           |                |                     |             |
| 8                            | T1   | All MCs   | 169          | 5.6 | 169           | 5.6 | 0.137     | 8.4         | LOS A            | 1.4               | 10.7     | 0.63      | 0.49           | 0.63                | 15.6        |
| Approach                     |      |           | 169          | 5.6 | 169           | 5.6 | 0.137     | 8.4         | LOS A            | 1.4               | 10.7     | 0.63      | 0.49           | 0.63                | 15.6        |
| All Vehicles                 |      |           | 944          | 8.0 | 944           | 8.0 | 0.442     | 9.7         | LOS A            | 5.3               | 40.4     | 0.72      | 0.59           | 0.72                | 21.3        |

Site Level of Service (LOS) Method: Delay (RTA NSW). Site LOS Method is specified in the Network Data dialog (Override Site Data tab).

Vehicle movement LOS values are based on average delay per movement.

Intersection and Approach LOS values are based on average delay for all vehicle movements.

Delay Model: SIDRA Standard (Control Delay: Geometric Delay is included).

Queue Model: SIDRA queue estimation methods are used for Back of Queue and Queue at Start of Green.

Gap-Acceptance Capacity Formula: SIDRA Standard (Akçelik M3D).

HV (%) values are calculated for All Movement Classes of All Heavy Vehicle Model Designation.

Arrival Flows used in performance calculations are adjusted to include any Initial Queued Demand and Upstream Capacity Constraint effects.

\* Critical Movement (Signal Timing)

| Pedestrian Movement Performance |          |           |             |                  |                       |        |           |                |             |              |             |
|---------------------------------|----------|-----------|-------------|------------------|-----------------------|--------|-----------|----------------|-------------|--------------|-------------|
| Mov ID                          | Crossing | Dem. Flow | Aver. Delay | Level of Service | AVERAGE BACK OF QUEUE |        | Prop. Que | Eff. Stop Rate | Travel Time | Travel Dist. | Aver. Speed |
|                                 |          | ped/h     | sec         |                  | [ Ped                 | Dist ] |           |                | sec         | m            | m/sec       |
|                                 |          |           |             |                  | ped                   | m      |           |                |             |              |             |
| South: Kent St (S)              |          |           |             |                  |                       |        |           |                |             |              |             |
| P1                              | Full     | 1827      | 13.1        | LOS B            | 1.9                   | 1.9    | 0.79      | 0.79           | 29.8        | 20.0         | 0.67        |
| All Pedestrians                 |          | 1827      | 13.1        | LOS B            | 1.9                   | 1.9    | 0.79      | 0.79           | 29.8        | 20.0         | 0.67        |

Level of Service (LOS) Method: SIDRA Pedestrian LOS Method (Based on Average Delay)  
 Pedestrian movement LOS values are based on average delay per pedestrian movement.  
 Intersection LOS value for Pedestrians is based on average delay for all pedestrian movements.

---

**SIDRA INTERSECTION 9.1 | Copyright © 2000-2022 Akcelik and Associates Pty Ltd | sidrasolutions.com**  
 Organisation: AECOM AUSTRALIA PTY LTD | Licence: NETWORK / Enterprise Level 1 | Processed: Friday, 14 July 2023 3:11:17 PM  
 Project: C:\Users\YeungM\AECOM\ANZ-NAC-Sydney Metro-Sydney Metro C&SW Operational Monitoring - General\400\_Technical\432\_Traffic Analysis\SIDRA Modelling\01 Models (Geometry Only)\Block 1\Rev1\\_Review\04 SM C&SW\_BGU (Block 1)\_PS.sip9

# MOVEMENT SUMMARY

Site: BGU12 [BGU12 Sussex St / Erskine St (Site Folder: Block 1 - 2023 AM Peak)]

Output produced by SIDRA INTERSECTION Version: 9.1.1.200

Network: BGU-N2 [BGU Network 3 (Network Folder: Block 1 Network - 2023 AM Peak)]

TCS 310

Site Category: (None)

Signals - EQUISAT (Fixed-Time/SCATS) Coordinated Cycle Time = 90 seconds (Network Site User-Given Phase Times)

| Vehicle Movement Performance |      |           |              |      |               |      |           |             |                  |                   |        |           |                |                     |             |
|------------------------------|------|-----------|--------------|------|---------------|------|-----------|-------------|------------------|-------------------|--------|-----------|----------------|---------------------|-------------|
| Mov ID                       | Turn | Mov Class | Demand Flows |      | Arrival Flows |      | Deg. Satn | Aver. Delay | Level of Service | 95% Back Of Queue |        | Prop. Que | Eff. Stop Rate | Aver. No. of Cycles | Aver. Speed |
|                              |      |           | [ Total HV ] | %    | [ Total HV ]  | %    |           |             |                  | [ Veh. veh        | Dist ] |           |                |                     |             |
| South: Sussex St (S)         |      |           |              |      |               |      |           |             |                  |                   |        |           |                |                     |             |
| 1                            | L2   | All MCs   | 68           | 4.6  | 68            | 4.6  | *0.464    | 42.6        | LOS D            | 6.9               | 50.3   | 0.92      | 0.77           | 0.92                | 13.9        |
| 2                            | T1   | All MCs   | 335          | 5.7  | 335           | 5.7  | 0.464     | 30.5        | LOS C            | 8.5               | 62.5   | 0.90      | 0.75           | 0.90                | 14.9        |
| Approach                     |      |           | 403          | 5.5  | 403           | 5.5  | 0.464     | 32.5        | LOS C            | 8.5               | 62.5   | 0.90      | 0.75           | 0.90                | 14.8        |
| East: Erskine St (E)         |      |           |              |      |               |      |           |             |                  |                   |        |           |                |                     |             |
| 4                            | L2   | All MCs   | 332          | 4.1  | 332           | 4.1  | *0.365    | 11.6        | LOS A            | 5.8               | 42.3   | 0.43      | 0.63           | 0.43                | 26.5        |
| 5                            | T1   | All MCs   | 106          | 11.9 | 106           | 11.9 | 0.170     | 2.7         | LOS A            | 0.8               | 6.4    | 0.15      | 0.20           | 0.15                | 27.6        |
| 6                            | R2   | All MCs   | 26           | 8.0  | 26            | 8.0  | 0.170     | 7.1         | LOS A            | 0.8               | 6.4    | 0.15      | 0.20           | 0.15                | 27.6        |
| Approach                     |      |           | 464          | 6.1  | 464           | 6.1  | 0.365     | 9.3         | LOS A            | 5.8               | 42.3   | 0.35      | 0.51           | 0.35                | 26.6        |
| North: Sussex St (N)         |      |           |              |      |               |      |           |             |                  |                   |        |           |                |                     |             |
| 7                            | L2   | All MCs   | 51           | 45.8 | 51            | 45.8 | 0.132     | 28.0        | LOS B            | 1.6               | 15.8   | 0.75      | 0.69           | 0.75                | 13.4        |
| 8                            | T1   | All MCs   | 231          | 11.9 | 231           | 11.9 | 0.186     | 21.6        | LOS B            | 3.5               | 27.0   | 0.73      | 0.59           | 0.73                | 23.8        |
| 9                            | R2   | All MCs   | 9            | 11.1 | 9             | 11.1 | *0.048    | 34.5        | LOS C            | 0.3               | 2.6    | 0.88      | 0.66           | 0.88                | 11.5        |
| Approach                     |      |           | 291          | 17.8 | 291           | 17.8 | 0.186     | 23.1        | LOS B            | 3.5               | 27.0   | 0.74      | 0.61           | 0.74                | 21.9        |
| West: Erskine St (W)         |      |           |              |      |               |      |           |             |                  |                   |        |           |                |                     |             |
| 10                           | L2   | All MCs   | 114          | 9.3  | 114           | 9.3  | 0.333     | 13.4        | LOS A            | 7.8               | 58.0   | 0.57      | 0.56           | 0.57                | 13.0        |
| 11                           | T1   | All MCs   | 276          | 6.1  | 276           | 6.1  | 0.333     | 11.8        | LOS A            | 7.8               | 58.0   | 0.59      | 0.58           | 0.59                | 12.2        |
| 12                           | R2   | All MCs   | 128          | 4.9  | 128           | 4.9  | 0.333     | 20.1        | LOS B            | 4.9               | 36.1   | 0.65      | 0.67           | 0.65                | 22.0        |
| Approach                     |      |           | 518          | 6.5  | 518           | 6.5  | 0.333     | 14.2        | LOS A            | 7.8               | 58.0   | 0.60      | 0.60           | 0.60                | 16.5        |
| All Vehicles                 |      |           | 1676         | 8.1  | 1676          | 8.1  | 0.464     | 18.8        | LOS B            | 8.5               | 62.5   | 0.63      | 0.61           | 0.63                | 19.5        |

Site Level of Service (LOS) Method: Delay (RTA NSW). Site LOS Method is specified in the Network Data dialog (Override Site Data tab).

Vehicle movement LOS values are based on average delay per movement.

Intersection and Approach LOS values are based on average delay for all vehicle movements.

Delay Model: SIDRA Standard (Control Delay: Geometric Delay is included).

Queue Model: SIDRA queue estimation methods are used for Back of Queue and Queue at Start of Green.

Gap-Acceptance Capacity Formula: SIDRA Standard (Akçelik M3D).

HV (%) values are calculated for All Movement Classes of All Heavy Vehicle Model Designation.

Arrival Flows used in performance calculations are adjusted to include any Initial Queued Demand and Upstream Capacity Constraint effects.

\* Critical Movement (Signal Timing)



| Pedestrian Movement Performance |          |           |             |                  |                       |        |           |                |             |              |             |
|---------------------------------|----------|-----------|-------------|------------------|-----------------------|--------|-----------|----------------|-------------|--------------|-------------|
| Mov ID                          | Crossing | Dem. Flow | Aver. Delay | Level of Service | AVERAGE BACK OF QUEUE |        | Prop. Que | Eff. Stop Rate | Travel Time | Travel Dist. | Aver. Speed |
|                                 |          | ped/h     | sec         |                  | [ Ped                 | Dist ] |           |                | sec         | m            | m/sec       |
|                                 |          |           |             |                  | ped                   | m      |           |                |             |              |             |
| South: Sussex St (S)            |          |           |             |                  |                       |        |           |                |             |              |             |
| P1                              | Full     | 227       | 33.3        | LOS D            | 0.5                   | 0.5    | 0.86      | 0.86           | 49.9        | 20.0         | 0.40        |
| East: Erskine St (E)            |          |           |             |                  |                       |        |           |                |             |              |             |
| P2                              | Full     | 217       | 35.0        | LOS D            | 0.5                   | 0.5    | 0.89      | 0.89           | 51.7        | 20.0         | 0.39        |
| North: Sussex St (N)            |          |           |             |                  |                       |        |           |                |             |              |             |
| P3                              | Full     | 443       | 33.6        | LOS D            | 1.0                   | 1.0    | 0.87      | 0.87           | 50.2        | 20.0         | 0.40        |
| West: Erskine St (W)            |          |           |             |                  |                       |        |           |                |             |              |             |
| P4                              | Full     | 312       | 33.4        | LOS D            | 0.7                   | 0.7    | 0.87      | 0.87           | 50.0        | 20.0         | 0.40        |
| All Pedestrians                 |          | 1199      | 33.7        | LOS D            | 1.0                   | 1.0    | 0.87      | 0.87           | 50.4        | 20.0         | 0.40        |

Level of Service (LOS) Method: SIDRA Pedestrian LOS Method (Based on Average Delay)  
 Pedestrian movement LOS values are based on average delay per pedestrian movement.  
 Intersection LOS value for Pedestrians is based on average delay for all pedestrian movements.

# MOVEMENT SUMMARY

Site: BGU13 [BGU13 Kent St / Erskine St (Site Folder: Block 1 - 2023 AM Peak)]

Output produced by SIDRA INTERSECTION Version: 9.1.1.200

Network: BGU-N2 [BGU Network 3 (Network Folder: Block 1 Network - 2023 AM Peak)]

TCS 307

Site Category: (None)

Signals - EQUISAT (Fixed-Time/SCATS) Coordinated Cycle Time = 90 seconds (Network Site User-Given Phase Times)

| Vehicle Movement Performance |      |           |              |      |               |      |           |             |                  |                   |        |           |                |                     |             |
|------------------------------|------|-----------|--------------|------|---------------|------|-----------|-------------|------------------|-------------------|--------|-----------|----------------|---------------------|-------------|
| Mov ID                       | Turn | Mov Class | Demand Flows |      | Arrival Flows |      | Deg. Satn | Aver. Delay | Level of Service | 95% Back Of Queue |        | Prop. Que | Eff. Stop Rate | Aver. No. of Cycles | Aver. Speed |
|                              |      |           | [ Total HV ] | %    | [ Total HV ]  | %    |           |             |                  | [ Veh. veh        | Dist ] |           |                |                     |             |
| South: Kent St (S)           |      |           |              |      |               |      |           |             |                  |                   |        |           |                |                     |             |
| 1                            | L2   | All MCs   | 116          | 3.6  | 116           | 3.6  | 0.162     | 22.0        | LOS B            | 3.2               | 23.5   | 0.68      | 0.69           | 0.68                | 18.8        |
| 2                            | T1   | All MCs   | 605          | 8.3  | 605           | 8.3  | *0.348    | 18.3        | LOS B            | 7.5               | 57.4   | 0.69      | 0.59           | 0.69                | 19.9        |
| 3                            | R2   | All MCs   | 17           | 0.0  | 17            | 0.0  | 0.055     | 12.1        | LOS A            | 2.6               | 7.0    | 0.49      | 0.41           | 0.49                | 22.2        |
| Approach                     |      |           | 738          | 7.4  | 738           | 7.4  | 0.348     | 18.8        | LOS B            | 7.5               | 57.4   | 0.69      | 0.60           | 0.69                | 19.8        |
| East: Erskine St (E)         |      |           |              |      |               |      |           |             |                  |                   |        |           |                |                     |             |
| 5                            | T1   | All MCs   | 252          | 6.7  | 252           | 6.7  | 0.255     | 24.4        | LOS B            | 4.9               | 36.2   | 0.78      | 0.65           | 0.78                | 7.1         |
| 6                            | R2   | All MCs   | 25           | 0.0  | 25            | 0.0  | 0.255     | 31.1        | LOS C            | 4.2               | 30.8   | 0.79      | 0.66           | 0.79                | 6.8         |
| Approach                     |      |           | 277          | 6.1  | 277           | 6.1  | 0.255     | 25.0        | LOS B            | 4.9               | 36.2   | 0.78      | 0.65           | 0.78                | 7.1         |
| North: Kent St (N)           |      |           |              |      |               |      |           |             |                  |                   |        |           |                |                     |             |
| 7                            | L2   | All MCs   | 1            | 0.0  | 1             | 0.0  | 0.019     | 11.6        | LOS A            | 1.3               | 3.5    | 0.48      | 0.36           | 0.48                | 18.6        |
| 8                            | T1   | All MCs   | 65           | 0.0  | 65            | 0.0  | 0.019     | 9.7         | LOS A            | 1.3               | 3.5    | 0.48      | 0.36           | 0.48                | 23.6        |
| 9                            | R2   | All MCs   | 97           | 7.6  | 97            | 7.6  | *0.688    | 51.3        | LOS D            | 4.5               | 33.9   | 1.00      | 0.87           | 1.15                | 5.9         |
| Approach                     |      |           | 163          | 4.5  | 163           | 4.5  | 0.688     | 34.4        | LOS C            | 4.5               | 33.9   | 0.79      | 0.66           | 0.88                | 11.9        |
| West: Erskine St (W)         |      |           |              |      |               |      |           |             |                  |                   |        |           |                |                     |             |
| 10                           | L2   | All MCs   | 121          | 5.2  | 121           | 5.2  | 0.297     | 19.0        | LOS B            | 3.9               | 28.9   | 0.56      | 0.61           | 0.56                | 11.6        |
| 11                           | T1   | All MCs   | 205          | 16.4 | 205           | 16.4 | *0.297    | 16.0        | LOS B            | 3.9               | 28.9   | 0.57      | 0.50           | 0.57                | 16.2        |
| Approach                     |      |           | 326          | 12.3 | 326           | 12.3 | 0.297     | 17.1        | LOS B            | 3.9               | 30.6   | 0.56      | 0.54           | 0.56                | 14.5        |
| All Vehicles                 |      |           | 1504         | 7.9  | 1504          | 7.9  | 0.688     | 21.3        | LOS B            | 7.5               | 57.4   | 0.69      | 0.60           | 0.70                | 15.8        |

Site Level of Service (LOS) Method: Delay (RTA NSW). Site LOS Method is specified in the Network Data dialog (Override Site Data tab).

Vehicle movement LOS values are based on average delay per movement.

Intersection and Approach LOS values are based on average delay for all vehicle movements.

Delay Model: SIDRA Standard (Control Delay: Geometric Delay is included).

Queue Model: SIDRA queue estimation methods are used for Back of Queue and Queue at Start of Green.

Gap-Acceptance Capacity Formula: SIDRA Standard (Akçelik M3D).

HV (%) values are calculated for All Movement Classes of All Heavy Vehicle Model Designation.

Arrival Flows used in performance calculations are adjusted to include any Initial Queued Demand and Upstream Capacity Constraint effects.

\* Critical Movement (Signal Timing)

| Pedestrian Movement Performance |          |           |             |                  |                       |        |           |                |             |              |             |
|---------------------------------|----------|-----------|-------------|------------------|-----------------------|--------|-----------|----------------|-------------|--------------|-------------|
| Mov ID                          | Crossing | Dem. Flow | Aver. Delay | Level of Service | AVERAGE BACK OF QUEUE |        | Prop. Que | Eff. Stop Rate | Travel Time | Travel Dist. | Aver. Speed |
|                                 |          | ped/h     | sec         |                  | [ Ped                 | Dist ] |           |                | sec         | m            | m/sec       |
|                                 |          |           |             |                  | ped                   | m      |           |                |             |              |             |
| South: Kent St (S)              |          |           |             |                  |                       |        |           |                |             |              |             |
| P1                              | Full     | 497       | 36.3        | LOS D            | 1.2                   | 1.2    | 0.91      | 0.91           | 53.0        | 20.0         | 0.38        |
| East: Erskine St (E)            |          |           |             |                  |                       |        |           |                |             |              |             |
| P2                              | Full     | 438       | 37.1        | LOS D            | 1.0                   | 1.0    | 0.92      | 0.92           | 53.8        | 20.0         | 0.37        |
| North: Kent St (N)              |          |           |             |                  |                       |        |           |                |             |              |             |
| P3                              | Full     | 368       | 36.1        | LOS D            | 0.9                   | 0.9    | 0.90      | 0.90           | 52.8        | 20.0         | 0.38        |
| West: Erskine St (W)            |          |           |             |                  |                       |        |           |                |             |              |             |
| P4                              | Full     | 539       | 36.4        | LOS D            | 1.3                   | 1.3    | 0.91      | 0.91           | 53.0        | 20.0         | 0.38        |
| All Pedestrians                 |          | 1842      | 36.5        | LOS D            | 1.3                   | 1.3    | 0.91      | 0.91           | 53.1        | 20.0         | 0.38        |

Level of Service (LOS) Method: SIDRA Pedestrian LOS Method (Based on Average Delay)

Pedestrian movement LOS values are based on average delay per pedestrian movement.

Intersection LOS value for Pedestrians is based on average delay for all pedestrian movements.

**SIDRA INTERSECTION 9.1 | Copyright © 2000-2022 Akcelik and Associates Pty Ltd | sidrasolutions.com**

Organisation: AECOM AUSTRALIA PTY LTD | Licence: NETWORK / Enterprise Level 1 | Processed: Friday, 14 July 2023 3:11:17 PM

Project: C:\Users\YeungMAECOMANZ-NAC-Sydney Metro-Sydney Metro C&SW Operational Monitoring - General\400\_Technical\432\_Traffic Analysis\SIDRA Modelling\01 Models (Geometry Only)\Block 1\Rev1\_Review\04 SM C&SW\_BGU (Block 1)\_PS.sip9

# MOVEMENT SUMMARY

Site: BGU14 [BGU14 Sussex St / King St (Site Folder: Block 1 - 2023 AM Peak)]

Output produced by SIDRA INTERSECTION Version: 9.1.1.200

Network: BGU-N2 [BGU Network 4 (Network Folder: Block 1 Network - 2023 AM Peak)]

TCS 284

Site Category: (None)

Signals - EQUISAT (Fixed-Time/SCATS) Coordinated Cycle Time = 90 seconds (Network Site User-Given Phase Times)

| Vehicle Movement Performance |      |           |              |      |               |      |           |             |                  |                   |          |           |                |                     |             |
|------------------------------|------|-----------|--------------|------|---------------|------|-----------|-------------|------------------|-------------------|----------|-----------|----------------|---------------------|-------------|
| Mov ID                       | Turn | Mov Class | Demand Flows |      | Arrival Flows |      | Deg. Satn | Aver. Delay | Level of Service | 95% Back Of Queue |          | Prop. Que | Eff. Stop Rate | Aver. No. of Cycles | Aver. Speed |
|                              |      |           | [ Total HV ] | %    | [ Total HV ]  | %    |           |             |                  | [ Veh. veh        | Dist ] m |           |                |                     |             |
| East: King St (E)            |      |           |              |      |               |      |           |             |                  |                   |          |           |                |                     |             |
| 4a                           | L1   | All MCs   | 35           | 0.0  | 35            | 0.0  | 0.045     | 41.5        | LOS C            | 1.5               | 4.0      | 1.00      | 0.71           | 1.00                | 18.9        |
| Approach                     |      |           | 35           | 0.0  | 35            | 0.0  | 0.045     | 41.5        | LOS C            | 1.5               | 4.0      | 1.00      | 0.71           | 1.00                | 18.9        |
| North: Sussex St (N)         |      |           |              |      |               |      |           |             |                  |                   |          |           |                |                     |             |
| 7                            | L2   | All MCs   | 46           | 31.8 | 46            | 31.8 | 0.905     | 58.9        | LOS E            | 16.4              | 123.6    | 1.00      | 1.18           | 1.39                | 10.6        |
| 8                            | T1   | All MCs   | 597          | 5.3  | 597           | 5.3  | *0.905    | 51.8        | LOS D            | 17.6              | 129.0    | 1.00      | 1.18           | 1.38                | 17.2        |
| Approach                     |      |           | 643          | 7.2  | 643           | 7.2  | 0.905     | 52.3        | LOS D            | 17.6              | 129.0    | 1.00      | 1.18           | 1.38                | 16.8        |
| SouthWest: King St (SW)      |      |           |              |      |               |      |           |             |                  |                   |          |           |                |                     |             |
| 30a                          | L1   | All MCs   | 437          | 5.1  | 437           | 5.1  | *0.504    | 21.1        | LOS B            | 13.2              | 96.2     | 0.74      | 0.78           | 0.74                | 33.3        |
| 32a                          | R1   | All MCs   | 1358         | 3.3  | 1358          | 3.3  | *0.527    | 14.7        | LOS B            | 13.5              | 97.3     | 0.60      | 0.70           | 0.60                | 34.0        |
| 32b                          | R3   | All MCs   | 392          | 6.2  | 392           | 6.2  | 0.384     | 12.4        | LOS A            | 7.7               | 56.4     | 0.48      | 0.74           | 0.48                | 37.3        |
| Approach                     |      |           | 2186         | 4.1  | 2186          | 4.1  | 0.527     | 15.5        | LOS B            | 13.5              | 97.3     | 0.61      | 0.72           | 0.61                | 34.5        |
| All Vehicles                 |      |           | 2864         | 4.8  | 2864          | 4.8  | 0.905     | 24.1        | LOS B            | 17.6              | 129.0    | 0.70      | 0.82           | 0.78                | 29.0        |

Site Level of Service (LOS) Method: Delay (RTA NSW). Site LOS Method is specified in the Network Data dialog (Override Site Data tab).

Vehicle movement LOS values are based on average delay per movement.

Intersection and Approach LOS values are based on average delay for all vehicle movements.

Delay Model: SIDRA Standard (Control Delay: Geometric Delay is included).

Queue Model: SIDRA queue estimation methods are used for Back of Queue and Queue at Start of Green.

Gap-Acceptance Capacity Formula: SIDRA Standard (Akçelik M3D).

HV (%) values are calculated for All Movement Classes of All Heavy Vehicle Model Designation.

Arrival Flows used in performance calculations are adjusted to include any Initial Queued Demand and Upstream Capacity Constraint effects.

\* Critical Movement (Signal Timing)

| Pedestrian Movement Performance |                 |                    |                    |                  |  |     |           |                |                    |                   |                      |
|---------------------------------|-----------------|--------------------|--------------------|------------------|--|-----|-----------|----------------|--------------------|-------------------|----------------------|
| Mov ID                          | Crossing        | Dem. Flow<br>ped/h | Aver. Delay<br>sec | Level of Service | AVERAGE BACK OF QUEUE<br>[ Ped Dist ]<br>ped m |     | Prop. Que | Eff. Stop Rate | Travel Time<br>sec | Travel Dist.<br>m | Aver. Speed<br>m/sec |
| South: Sussex St (S)            |                 |                    |                    |                  |  |     |           |                |                    |                   |                      |
| P1                              | Full            | 165                | 40.4               | LOS E            | 0.4  | 0.4 | 0.95      | 0.95           | 57.1               | 20.0              | 0.35                 |
| East: King St (E)               |                 |                    |                    |                  |  |     |           |                |                    |                   |                      |
| P2                              | Full            | 176                | 36.7               | LOS D            | 0.4  | 0.4 | 0.91      | 0.91           | 53.4               | 20.0              | 0.37                 |
| North: Sussex St (N)            |                 |                    |                    |                  |  |     |           |                |                    |                   |                      |
| P3                              | Full            | 422                | 36.2               | LOS D            | 1.0  | 1.0 | 0.90      | 0.90           | 52.9               | 20.0              | 0.38                 |
| SouthWest: King St (SW)         |                 |                    |                    |                  |  |     |           |                |                    |                   |                      |
| P8                              | Full            | 255                | 37.8               | LOS D            | 0.6  | 0.6 | 0.92      | 0.92           | 204.4              | 200.0             | 0.98                 |
| P8B                             | Slip/<br>Bypass | 221                | 40.5               | LOS E            | 0.5  | 0.5 | 0.95      | 0.95           | 207.2              | 200.0             | 0.97                 |
| All Pedestrians                 |                 | 1239               | 37.9               | LOS D            | 1.0  | 1.0 | 0.92      | 0.92           | 112.2              | 89.1              | 0.79                 |

Level of Service (LOS) Method: SIDRA Pedestrian LOS Method (Based on Average Delay)  
 Pedestrian movement LOS values are based on average delay per pedestrian movement.  
 Intersection LOS value for Pedestrians is based on average delay for all pedestrian movements.

# MOVEMENT SUMMARY

Site: BGU15 [BGU15 Kent St / King St (Site Folder: Block 1 - 2023 AM Peak)]

Output produced by SIDRA INTERSECTION Version: 9.1.1.200

Network: BGU-N2 [BGU Network 4 (Network Folder: Block 1 Network - 2023 AM Peak)]

TCS 283

Site Category: NA

Signals - EQUISAT (Fixed-Time/SCATS) Coordinated Cycle Time = 90 seconds (Network Site User-Given Phase Times)

| Vehicle Movement Performance |      |           |              |     |               |     |           |             |                  |                   |        |           |                |                     |             |
|------------------------------|------|-----------|--------------|-----|---------------|-----|-----------|-------------|------------------|-------------------|--------|-----------|----------------|---------------------|-------------|
| Mov ID                       | Turn | Mov Class | Demand Flows |     | Arrival Flows |     | Deg. Satn | Aver. Delay | Level of Service | 95% Back Of Queue |        | Prop. Que | Eff. Stop Rate | Aver. No. of Cycles | Aver. Speed |
|                              |      |           | [ Total HV ] | %   | [ Total HV ]  | %   |           |             |                  | [ Veh. veh        | Dist ] |           |                |                     |             |
|                              |      |           | veh/h        | %   | veh/h         | %   | v/c       | sec         |                  | m                 |        |           |                |                     | km/h        |
| South: Kent St (S)           |      |           |              |     |               |     |           |             |                  |                   |        |           |                |                     |             |
| 1                            | L2   | All MCs   | 4            | 0.0 | 4             | 0.0 | 0.110     | 41.6        | LOS C            | 3.1               | 8.3    | 0.93      | 0.69           | 0.93                | 14.2        |
| 2                            | T1   | All MCs   | 475          | 9.8 | 475           | 9.8 | *0.515    | 34.6        | LOS C            | 7.9               | 60.8   | 0.93      | 0.75           | 0.93                | 21.2        |
| 3                            | R2   | All MCs   | 174          | 6.1 | 174           | 6.1 | *0.488    | 40.0        | LOS C            | 6.5               | 47.9   | 0.94      | 0.78           | 0.94                | 14.7        |
| Approach                     |      |           | 653          | 8.7 | 653           | 8.7 | 0.515     | 36.1        | LOS C            | 7.9               | 60.8   | 0.93      | 0.76           | 0.93                | 19.6        |
| East: King St (E)            |      |           |              |     |               |     |           |             |                  |                   |        |           |                |                     |             |
| 5                            | T1   | All MCs   | 7            | 0.0 | 7             | 0.0 | 0.033     | 41.4        | LOS C            | 0.4               | 1.1    | 0.97      | 0.62           | 0.97                | 4.6         |
| 6                            | R2   | All MCs   | 2            | 0.0 | 2             | 0.0 | 0.033     | 53.2        | LOS D            | 0.4               | 1.1    | 0.97      | 0.62           | 0.97                | 13.8        |
| Approach                     |      |           | 9            | 0.0 | 9             | 0.0 | 0.033     | 44.1        | LOS D            | 0.4               | 1.1    | 0.97      | 0.62           | 0.97                | 7.2         |
| North: Kent St (N)           |      |           |              |     |               |     |           |             |                  |                   |        |           |                |                     |             |
| 7                            | L2   | All MCs   | 7            | 0.0 | 7             | 0.0 | 0.059     | 41.2        | LOS C            | 1.6               | 4.4    | 0.93      | 0.66           | 0.93                | 11.4        |
| 8                            | T1   | All MCs   | 35           | 0.0 | 35            | 0.0 | 0.059     | 37.8        | LOS C            | 1.6               | 4.4    | 0.93      | 0.66           | 0.93                | 20.2        |
| 9                            | R2   | All MCs   | 23           | 0.0 | 23            | 0.0 | 0.076     | 42.2        | LOS C            | 0.9               | 2.5    | 0.93      | 0.68           | 0.93                | 12.9        |
| Approach                     |      |           | 65           | 0.0 | 65            | 0.0 | 0.076     | 39.8        | LOS C            | 1.6               | 4.4    | 0.93      | 0.67           | 0.93                | 16.8        |
| West: King St (W)            |      |           |              |     |               |     |           |             |                  |                   |        |           |                |                     |             |
| 10                           | L2   | All MCs   | 263          | 4.4 | 263           | 4.4 | *0.549    | 26.4        | LOS B            | 9.6               | 70.4   | 0.67      | 0.65           | 0.67                | 20.9        |
| 11                           | T1   | All MCs   | 1119         | 4.8 | 1119          | 4.8 | 0.549     | 8.8         | LOS A            | 9.8               | 71.6   | 0.49      | 0.44           | 0.49                | 22.1        |
| Approach                     |      |           | 1382         | 4.7 | 1382          | 4.7 | 0.549     | 12.2        | LOS A            | 9.8               | 71.6   | 0.52      | 0.48           | 0.52                | 21.7        |
| All Vehicles                 |      |           | 2109         | 5.8 | 2109          | 5.8 | 0.549     | 20.6        | LOS B            | 9.8               | 71.6   | 0.66      | 0.58           | 0.66                | 20.2        |

Site Level of Service (LOS) Method: Delay (RTA NSW). Site LOS Method is specified in the Network Data dialog (Override Site Data tab).

Vehicle movement LOS values are based on average delay per movement.

Intersection and Approach LOS values are based on average delay for all vehicle movements.

Delay Model: SIDRA Standard (Control Delay: Geometric Delay is included).

Queue Model: SIDRA queue estimation methods are used for Back of Queue and Queue at Start of Green.

Gap-Acceptance Capacity Formula: SIDRA Standard (Akçelik M3D).

HV (%) values are calculated for All Movement Classes of All Heavy Vehicle Model Designation.

Arrival Flows used in performance calculations are adjusted to include any Initial Queued Demand and Upstream Capacity Constraint effects.

\* Critical Movement (Signal Timing)

| Pedestrian Movement Performance |          |           |             |                  |                       |        |           |                |             |              |             |
|---------------------------------|----------|-----------|-------------|------------------|-----------------------|--------|-----------|----------------|-------------|--------------|-------------|
| Mov ID                          | Crossing | Dem. Flow | Aver. Delay | Level of Service | AVERAGE BACK OF QUEUE |        | Prop. Que | Eff. Stop Rate | Travel Time | Travel Dist. | Aver. Speed |
|                                 |          | ped/h     | sec         |                  | [ Ped                 | Dist ] |           |                | sec         | m            | m/sec       |
|                                 |          |           |             |                  | ped                   | m      |           |                |             |              |             |
| South: Kent St (S)              |          |           |             |                  |                       |        |           |                |             |              |             |
| P1                              | Full     | 352       | 37.0        | LOS D            | 0.8                   | 0.8    | 0.91      | 0.91           | 53.7        | 20.0         | 0.37        |
| East: King St (E)               |          |           |             |                  |                       |        |           |                |             |              |             |
| P2                              | Full     | 225       | 37.7        | LOS D            | 0.5                   | 0.5    | 0.92      | 0.92           | 54.4        | 20.0         | 0.37        |
| North: Kent St (N)              |          |           |             |                  |                       |        |           |                |             |              |             |
| P3                              | Full     | 505       | 38.2        | LOS D            | 1.2                   | 1.2    | 0.93      | 0.93           | 54.8        | 20.0         | 0.36        |
| West: King St (W)               |          |           |             |                  |                       |        |           |                |             |              |             |
| P4                              | Full     | 449       | 38.1        | LOS D            | 1.1                   | 1.1    | 0.93      | 0.93           | 54.7        | 20.0         | 0.37        |
| All Pedestrians                 |          | 1532      | 37.8        | LOS D            | 1.2                   | 1.2    | 0.92      | 0.92           | 54.5        | 20.0         | 0.37        |

Level of Service (LOS) Method: SIDRA Pedestrian LOS Method (Based on Average Delay)

Pedestrian movement LOS values are based on average delay per pedestrian movement.

Intersection LOS value for Pedestrians is based on average delay for all pedestrian movements.

**SIDRA INTERSECTION 9.1 | Copyright © 2000-2022 Akcelik and Associates Pty Ltd | sidrasolutions.com**

Organisation: AECOM AUSTRALIA PTY LTD | Licence: NETWORK / Enterprise Level 1 | Processed: Friday, 14 July 2023 3:11:19 PM

Project: C:\Users\YeungMA\AECOM\ANZ-NAC-Sydney Metro-Sydney Metro C&SW Operational Monitoring - General\400\_Technical\432\_Traffic Analysis\SIDRA Modelling\01 Models (Geometry Only)\Block 1\Rev1\_Review\04 SM C&SW\_BGU (Block 1)\_PS.sip9

# MOVEMENT SUMMARY

Site: BGU18 [BGU18 Shelley St / Erskine St (Site Folder: Block 1 - 2023 AM Peak)]

Output produced by SIDRA INTERSECTION Version: 9.1.1.200

Network: BGU-N2 [BGU Network 3 (Network Folder: Block 1 Network - 2023 AM Peak)]

TCS 305

Site Category: (None)

Signals - EQUISAT (Fixed-Time/SCATS) Isolated Cycle Time = 45 seconds (Site User-Given Phase Times)

| Vehicle Movement Performance |      |           |                       |      |                       |      |           |             |                  |                   |               |           |                |                     |                  |
|------------------------------|------|-----------|-----------------------|------|-----------------------|------|-----------|-------------|------------------|-------------------|---------------|-----------|----------------|---------------------|------------------|
| Mov ID                       | Turn | Mov Class | Demand Flows          |      | Arrival Flows         |      | Deg. Satn | Aver. Delay | Level of Service | 95% Back Of Queue |               | Prop. Que | Eff. Stop Rate | Aver. No. of Cycles | Aver. Speed km/h |
|                              |      |           | [ Total HV ]<br>veh/h | %    | [ Total HV ]<br>veh/h | %    |           |             |                  | [ Veh. veh        | [ Dist ]<br>m |           |                |                     |                  |
| South: Shelley St (S)        |      |           |                       |      |                       |      |           |             |                  |                   |               |           |                |                     |                  |
| 1                            | L2   | All MCs   | 25                    | 4.2  | 25                    | 4.2  | 0.197     | 17.8        | LOS B            | 2.0               | 14.3          | 0.73      | 0.61           | 0.73                | 17.3             |
| 2                            | T1   | All MCs   | 101                   | 3.1  | 101                   | 3.1  | 0.197     | 10.3        | LOS A            | 2.0               | 14.3          | 0.73      | 0.61           | 0.73                | 23.7             |
| 3                            | R2   | All MCs   | 282                   | 7.1  | 282                   | 7.1  | *0.568    | 17.5        | LOS B            | 5.4               | 39.9          | 0.87      | 0.80           | 0.87                | 14.7             |
| Approach                     |      |           | 408                   | 5.9  | 408                   | 5.9  | 0.568     | 15.8        | LOS B            | 5.4               | 39.9          | 0.83      | 0.74           | 0.83                | 17.2             |
| East: Erskine St (E)         |      |           |                       |      |                       |      |           |             |                  |                   |               |           |                |                     |                  |
| 4                            | L2   | All MCs   | 44                    | 14.3 | 44                    | 14.3 | 0.103     | 17.3        | LOS B            | 0.8               | 6.0           | 0.78      | 0.69           | 0.78                | 17.6             |
| 5                            | T1   | All MCs   | 72                    | 13.2 | 72                    | 13.2 | *0.291    | 12.1        | LOS A            | 2.4               | 17.7          | 0.78      | 0.68           | 0.78                | 16.5             |
| 6                            | R2   | All MCs   | 68                    | 1.5  | 68                    | 1.5  | 0.291     | 16.3        | LOS B            | 2.4               | 17.7          | 0.78      | 0.68           | 0.78                | 17.7             |
| Approach                     |      |           | 184                   | 9.1  | 184                   | 9.1  | 0.291     | 14.9        | LOS B            | 2.4               | 17.7          | 0.78      | 0.68           | 0.78                | 17.2             |
| North: Shelley St (N)        |      |           |                       |      |                       |      |           |             |                  |                   |               |           |                |                     |                  |
| 7                            | L2   | All MCs   | 101                   | 3.1  | 101                   | 3.1  | 0.235     | 15.7        | LOS B            | 1.7               | 12.1          | 0.76      | 0.72           | 0.76                | 13.7             |
| 8                            | T1   | All MCs   | 7                     | 0.0  | 7                     | 0.0  | 0.033     | 11.1        | LOS A            | 0.2               | 1.9           | 0.72      | 0.57           | 0.72                | 22.7             |
| 9                            | R2   | All MCs   | 7                     | 42.9 | 7                     | 42.9 | 0.033     | 16.4        | LOS B            | 0.2               | 1.9           | 0.72      | 0.57           | 0.72                | 14.0             |
| Approach                     |      |           | 116                   | 5.5  | 116                   | 5.5  | 0.235     | 15.5        | LOS B            | 1.7               | 12.1          | 0.75      | 0.70           | 0.75                | 14.4             |
| West: Erskine St (W)         |      |           |                       |      |                       |      |           |             |                  |                   |               |           |                |                     |                  |
| 10                           | L2   | All MCs   | 5                     | 20.0 | 5                     | 20.0 | 0.134     | 16.6        | LOS B            | 0.9               | 7.2           | 0.71      | 0.56           | 0.71                | 20.2             |
| 11                           | T1   | All MCs   | 136                   | 8.5  | 136                   | 8.5  | 0.134     | 10.8        | LOS A            | 1.3               | 9.5           | 0.71      | 0.56           | 0.71                | 14.0             |
| 12                           | R2   | All MCs   | 3                     | 0.0  | 3                     | 0.0  | 0.134     | 16.5        | LOS B            | 1.3               | 9.5           | 0.71      | 0.56           | 0.71                | 22.1             |
| Approach                     |      |           | 144                   | 8.8  | 144                   | 8.8  | 0.134     | 11.1        | LOS A            | 1.3               | 9.5           | 0.71      | 0.56           | 0.71                | 14.6             |
| All Vehicles                 |      |           | 853                   | 7.0  | 853                   | 7.0  | 0.568     | 14.8        | LOS B            | 5.4               | 39.9          | 0.79      | 0.69           | 0.79                | 16.5             |

Site Level of Service (LOS) Method: Delay (RTA NSW). Site LOS Method is specified in the Network Data dialog (Override Site Data tab).

Vehicle movement LOS values are based on average delay per movement.

Intersection and Approach LOS values are based on average delay for all vehicle movements.

Delay Model: SIDRA Standard (Control Delay: Geometric Delay is included).

Queue Model: SIDRA queue estimation methods are used for Back of Queue and Queue at Start of Green.

Gap-Acceptance Capacity Formula: SIDRA Standard (Akçelik M3D).

HV (%) values are calculated for All Movement Classes of All Heavy Vehicle Model Designation.

Arrival Flows used in performance calculations are adjusted to include any Initial Queued Demand and Upstream Capacity Constraint effects.

\* Critical Movement (Signal Timing)



| Pedestrian Movement Performance |          |           |             |                  |                       |        |           |                |             |              |             |
|---------------------------------|----------|-----------|-------------|------------------|-----------------------|--------|-----------|----------------|-------------|--------------|-------------|
| Mov ID                          | Crossing | Dem. Flow | Aver. Delay | Level of Service | AVERAGE BACK OF QUEUE |        | Prop. Que | Eff. Stop Rate | Travel Time | Travel Dist. | Aver. Speed |
|                                 |          | ped/h     | sec         |                  | [ Ped                 | Dist ] |           |                | sec         | m            | m/sec       |
|                                 |          |           |             |                  | ped                   | m      |           |                |             |              |             |
| South: Shelley St (S)           |          |           |             |                  |                       |        |           |                |             |              |             |
| P1                              | Full     | 166       | 11.5        | LOS B            | 0.2                   | 0.2    | 0.72      | 0.72           | 178.1       | 200.0        | 1.12        |
| East: Erskine St (E)            |          |           |             |                  |                       |        |           |                |             |              |             |
| P2                              | Full     | 81        | 11.4        | LOS B            | 0.1                   | 0.1    | 0.71      | 0.71           | 178.1       | 200.0        | 1.12        |
| North: Shelley St (N)           |          |           |             |                  |                       |        |           |                |             |              |             |
| P3                              | Full     | 146       | 11.4        | LOS B            | 0.1                   | 0.1    | 0.72      | 0.72           | 178.1       | 200.0        | 1.12        |
| West: Erskine St (W)            |          |           |             |                  |                       |        |           |                |             |              |             |
| P4                              | Full     | 235       | 11.5        | LOS B            | 0.2                   | 0.2    | 0.72      | 0.72           | 178.2       | 200.0        | 1.12        |
| All Pedestrians                 |          | 628       | 11.5        | LOS B            | 0.2                   | 0.2    | 0.72      | 0.72           | 178.1       | 200.0        | 1.12        |

Level of Service (LOS) Method: SIDRA Pedestrian LOS Method (Based on Average Delay)  
 Pedestrian movement LOS values are based on average delay per pedestrian movement.  
 Intersection LOS value for Pedestrians is based on average delay for all pedestrian movements.

# MOVEMENT SUMMARY

Site: BUG01 [BGU01 Hickson Rd / Towns PI (Site Folder: Block 1 - 2023 PM Peak)]

Output produced by SIDRA INTERSECTION Version: 9.1.1.200

Network: BGU-N1 [BGU Network 1 (Network Folder: Block 1 Network - 2023 PM Peak)]

Site Category: (None)  
Give-Way (Two-Way)

| Vehicle Movement Performance |      |           |              |     |               |     |           |             |                  |                   |        |           |                |                     |             |
|------------------------------|------|-----------|--------------|-----|---------------|-----|-----------|-------------|------------------|-------------------|--------|-----------|----------------|---------------------|-------------|
| Mov ID                       | Turn | Mov Class | Demand Flows |     | Arrival Flows |     | Deg. Satn | Aver. Delay | Level of Service | 95% Back Of Queue |        | Prop. Que | Eff. Stop Rate | Aver. No. of Cycles | Aver. Speed |
|                              |      |           | [ Total HV ] | %   | [ Total HV ]  | %   |           |             |                  | [ Veh. veh        | Dist ] |           |                |                     |             |
| East: Hickson Rd (E)         |      |           |              |     |               |     |           |             |                  |                   |        |           |                |                     |             |
| 4a                           | L1   | All MCs   | 120          | 6.1 | 120           | 6.1 | 0.188     | 4.2         | LOS A            | 0.8               | 6.1    | 0.40      | 0.54           | 0.40                | 37.3        |
| 6a                           | R1   | All MCs   | 83           | 0.0 | 83            | 0.0 | 0.188     | 6.0         | LOS A            | 0.8               | 6.1    | 0.40      | 0.54           | 0.40                | 34.8        |
| Approach                     |      |           | 203          | 3.6 | 203           | 3.6 | 0.188     | 5.0         | NA               | 0.8               | 6.1    | 0.40      | 0.54           | 0.40                | 36.8        |
| NorthWest: Towns PI (NW)     |      |           |              |     |               |     |           |             |                  |                   |        |           |                |                     |             |
| 27a                          | L1   | All MCs   | 145          | 2.9 | 145           | 2.9 | 0.279     | 5.0         | LOS A            | 1.2               | 8.4    | 0.55      | 0.72           | 0.60                | 34.4        |
| 29                           | R2   | All MCs   | 82           | 5.1 | 82            | 5.1 | 0.279     | 8.2         | LOS A            | 1.2               | 8.4    | 0.55      | 0.72           | 0.60                | 35.8        |
| Approach                     |      |           | 227          | 3.7 | 227           | 3.7 | 0.279     | 6.1         | LOS A            | 1.2               | 8.4    | 0.55      | 0.72           | 0.60                | 35.0        |
| SouthWest: Hickson Rd (SW)   |      |           |              |     |               |     |           |             |                  |                   |        |           |                |                     |             |
| 30                           | L2   | All MCs   | 116          | 6.4 | 116           | 6.4 | 0.278     | 4.1         | LOS A            | 1.5               | 10.9   | 0.32      | 0.44           | 0.32                | 37.3        |
| 32a                          | R1   | All MCs   | 280          | 4.5 | 280           | 4.5 | 0.278     | 3.1         | LOS A            | 1.5               | 10.9   | 0.32      | 0.44           | 0.32                | 38.0        |
| Approach                     |      |           | 396          | 5.1 | 396           | 5.1 | 0.278     | 3.4         | NA               | 1.5               | 10.9   | 0.32      | 0.44           | 0.32                | 37.8        |
| All Vehicles                 |      |           | 826          | 4.3 | 826           | 4.3 | 0.279     | 4.5         | NA               | 1.5               | 10.9   | 0.40      | 0.54           | 0.41                | 37.0        |

Site Level of Service (LOS) Method: Delay (RTA NSW). Site LOS Method is specified in the Network Data dialog (Override Site Data tab).

Vehicle movement LOS values are based on average delay per movement.

Minor Road Approach LOS values are based on average delay for all vehicle movements.

NA (TWSC): Level of Service is not defined for major road approaches or the intersection as a whole for Two-Way Sign Control (HCM LOS rule).

Two-Way Sign Control Capacity Model: SIDRA Standard.

Delay Model: SIDRA Standard (Control Delay: Geometric Delay is included).

Queue Model: SIDRA queue estimation methods are used for Back of Queue and Queue at Start of Gap.

Gap-Acceptance Capacity Formula: SIDRA Standard (Akçelik M3D).

HV (%) values are calculated for All Movement Classes of All Heavy Vehicle Model Designation.

Arrival Flows used in performance calculations are adjusted to include any Initial Queued Demand and Upstream Capacity Constraint effects.

---

**SIDRA INTERSECTION 9.1 | Copyright © 2000-2022 Akcelik and Associates Pty Ltd | sidrasolutions.com**

Organisation: AECOM AUSTRALIA PTY LTD | Licence: NETWORK / Enterprise Level 1 | Processed: Friday, 14 July 2023 3:14:10 PM

Project: C:\Users\Yeung\AECOMANZ-NAC-Sydney Metro-Sydney Metro C&SW Operational Monitoring - General\400\_Technical\432\_Traffic Analysis\SIDRA Modelling\01 Models (Geometry Only)\Block 1\Rev1\\_Review\04 SM C&SW\_BGU (Block 1)\_PS.sip9

# MOVEMENT SUMMARY

Site: BGU02 [BGU02 Dalgety Rd / Towns PI (Site Folder: Block 1 - 2023 PM Peak)]

Output produced by SIDRA INTERSECTION Version: 9.1.1.200

Network: BGU-N1 [BGU Network 1 (Network Folder: Block 1 Network - 2023 PM Peak)]

Site Category: (None)  
Roundabout

| Vehicle Movement Performance |      |           |              |     |               |     |           |             |                  |                   |          |           |                |                     |             |
|------------------------------|------|-----------|--------------|-----|---------------|-----|-----------|-------------|------------------|-------------------|----------|-----------|----------------|---------------------|-------------|
| Mov ID                       | Turn | Mov Class | Demand Flows |     | Arrival Flows |     | Deg. Satn | Aver. Delay | Level of Service | 95% Back Of Queue |          | Prop. Que | Eff. Stop Rate | Aver. No. of Cycles | Aver. Speed |
|                              |      |           | [ Total HV ] | %   | [ Total HV ]  | %   |           |             |                  | [ Veh. veh        | Dist ] m |           |                |                     |             |
| South: Dalgety Rd (S)        |      |           |              |     |               |     |           |             |                  |                   |          |           |                |                     |             |
| 30                           | L2   | All MCs   | 8            | 0.0 | 8             | 0.0 | 0.176     | 7.2         | LOS A            | 1.1               | 7.7      | 0.41      | 0.58           | 0.41                | 23.9        |
| 3b                           | R3   | All MCs   | 184          | 2.9 | 184           | 2.9 | 0.176     | 7.4         | LOS A            | 1.1               | 7.7      | 0.41      | 0.58           | 0.41                | 31.1        |
| 32u                          | U    | All MCs   | 3            | 0.0 | 3             | 0.0 | 0.176     | 8.0         | LOS A            | 1.1               | 7.7      | 0.41      | 0.58           | 0.41                | 34.0        |
| Approach                     |      |           | 196          | 2.7 | 196           | 2.7 | 0.176     | 7.4         | LOS A            | 1.1               | 7.7      | 0.41      | 0.58           | 0.41                | 30.7        |
| SouthEast: Towns PI (SE)     |      |           |              |     |               |     |           |             |                  |                   |          |           |                |                     |             |
| 21b                          | L3   | All MCs   | 11           | 0.0 | 11            | 0.0 | 0.134     | 2.9         | LOS A            | 0.8               | 6.2      | 0.21      | 0.67           | 0.21                | 31.8        |
| 21a                          | L1   | All MCs   | 143          | 5.9 | 143           | 5.9 | 0.134     | 8.3         | LOS A            | 0.8               | 6.2      | 0.21      | 0.67           | 0.21                | 16.9        |
| 23u                          | U    | All MCs   | 23           | 0.0 | 23            | 0.0 | 0.134     | 7.2         | LOS A            | 0.8               | 6.2      | 0.21      | 0.67           | 0.21                | 23.6        |
| Approach                     |      |           | 177          | 4.8 | 177           | 4.8 | 0.134     | 7.8         | LOS A            | 0.8               | 6.2      | 0.21      | 0.67           | 0.21                | 18.5        |
| West: Parking Access (W)     |      |           |              |     |               |     |           |             |                  |                   |          |           |                |                     |             |
| 12a                          | R1   | All MCs   | 24           | 0.0 | 24            | 0.0 | 0.064     | 1.3         | LOS A            | 0.4               | 2.6      | 0.43      | 0.24           | 0.43                | 9.6         |
| 29                           | R2   | All MCs   | 44           | 0.0 | 44            | 0.0 | 0.064     | 1.3         | LOS A            | 0.4               | 2.6      | 0.43      | 0.24           | 0.43                | 21.6        |
| 29u                          | U    | All MCs   | 1            | 0.0 | 1             | 0.0 | 0.064     | 1.3         | LOS A            | 0.4               | 2.6      | 0.43      | 0.24           | 0.43                | 9.7         |
| Approach                     |      |           | 69           | 0.0 | 69            | 0.0 | 0.064     | 1.3         | LOS A            | 0.4               | 2.6      | 0.43      | 0.24           | 0.43                | 18.6        |
| All Vehicles                 |      |           | 442          | 3.1 | 442           | 3.1 | 0.176     | 6.6         | LOS A            | 1.1               | 7.7      | 0.33      | 0.56           | 0.33                | 23.7        |

Site Level of Service (LOS) Method: Delay (RTA NSW). Site LOS Method is specified in the Network Data dialog (Override Site Data tab).

Vehicle movement LOS values are based on average delay per movement.

Intersection and Approach LOS values are based on average delay for all vehicle movements.

Roundabout Capacity Model: SIDRA Standard.

Delay Model: SIDRA Standard (Control Delay: Geometric Delay is included).

Queue Model: SIDRA queue estimation methods are used for Back of Queue and Queue at Start of Gap.

Gap-Acceptance Capacity Formula: SIDRA Standard (Akçelik M3D).

HV (%) values are calculated for All Movement Classes of All Heavy Vehicle Model Designation.

Arrival Flows used in performance calculations are adjusted to include any Initial Queued Demand and Upstream Capacity Constraint effects.

---

**SIDRA INTERSECTION 9.1 | Copyright © 2000-2022 Akcelik and Associates Pty Ltd | sidrasolutions.com**

Organisation: AECOM AUSTRALIA PTY LTD | Licence: NETWORK / Enterprise Level 1 | Processed: Friday, 14 July 2023 3:14:10 PM

Project: C:\Users\Yeung\AECOM\ANZ-NAC-Sydney Metro-Sydney Metro C&SW Operational Monitoring - General\400\_Technical\432\_Traffic Analysis\SIDRA Modelling\01 Models (Geometry Only)\Block 1\Rev1\\_Review\04 SM C&SW\_BGU (Block 1)\_PS.sip9

# MOVEMENT SUMMARY

Site: **BGU03 [BGU03 Kent St / Argyle St (Site Folder: Block 1 - 2023 PM Peak)]**

Output produced by **SIDRA INTERSECTION Version: 9.1.1.200**

Site Category: (None)  
Give-Way (Two-Way)

| Vehicle Movement Performance |      |           |              |      |               |      |           |             |                  |                   |          |           |                |                     |             |
|------------------------------|------|-----------|--------------|------|---------------|------|-----------|-------------|------------------|-------------------|----------|-----------|----------------|---------------------|-------------|
| Mov ID                       | Turn | Mov Class | Demand Flows |      | Arrival Flows |      | Deg. Satn | Aver. Delay | Level of Service | 95% Back Of Queue |          | Prop. Que | Eff. Stop Rate | Aver. No. of Cycles | Aver. Speed |
|                              |      |           | [ Total HV ] | %    | [ Total HV ]  | %    |           |             |                  | [ Veh. ]          | [ Dist ] |           |                |                     |             |
|                              |      |           | veh/h        | %    | veh/h         | %    | v/c       | sec         |                  | veh               | m        |           |                |                     | km/h        |
| South: Kent St (S)           |      |           |              |      |               |      |           |             |                  |                   |          |           |                |                     |             |
| 1                            | L2   | All MCs   | 100          | 1.1  | 100           | 1.1  | 0.414     | 4.9         | LOS A            | 2.4               | 16.9     | 0.52      | 0.70           | 0.64                | 35.7        |
| 2                            | T1   | All MCs   | 32           | 3.3  | 32            | 3.3  | 0.414     | 5.4         | LOS A            | 2.4               | 16.9     | 0.52      | 0.70           | 0.64                | 34.6        |
| 3                            | R2   | All MCs   | 212          | 3.0  | 212           | 3.0  | 0.414     | 7.8         | LOS A            | 2.4               | 16.9     | 0.52      | 0.70           | 0.64                | 34.7        |
| Approach                     |      |           | 343          | 2.5  | 343           | 2.5  | 0.414     | 6.7         | LOS A            | 2.4               | 16.9     | 0.52      | 0.70           | 0.64                | 35.0        |
| East: Argyle St (E)          |      |           |              |      |               |      |           |             |                  |                   |          |           |                |                     |             |
| 4                            | L2   | All MCs   | 122          | 0.9  | 122           | 0.9  | 0.193     | 3.5         | LOS A            | 1.0               | 7.0      | 0.04      | 0.24           | 0.04                | 37.8        |
| 5                            | T1   | All MCs   | 113          | 3.7  | 113           | 3.7  | 0.193     | 0.0         | LOS A            | 1.0               | 7.0      | 0.04      | 0.24           | 0.04                | 37.9        |
| 6                            | R2   | All MCs   | 8            | 0.0  | 8             | 0.0  | 0.193     | 3.6         | LOS A            | 1.0               | 7.0      | 0.04      | 0.24           | 0.04                | 34.1        |
| Approach                     |      |           | 243          | 2.2  | 243           | 2.2  | 0.193     | 1.9         | NA               | 1.0               | 7.0      | 0.04      | 0.24           | 0.04                | 37.8        |
| North: Kent St (N)           |      |           |              |      |               |      |           |             |                  |                   |          |           |                |                     |             |
| 7                            | L2   | All MCs   | 4            | 25.0 | 4             | 25.0 | 0.032     | 7.8         | LOS A            | 0.1               | 0.8      | 0.36      | 0.90           | 0.36                | 27.1        |
| 8                            | T1   | All MCs   | 18           | 0.0  | 18            | 0.0  | 0.032     | 9.2         | LOS A            | 0.1               | 0.8      | 0.36      | 0.90           | 0.36                | 33.5        |
| 9                            | R2   | All MCs   | 2            | 0.0  | 2             | 0.0  | 0.032     | 8.8         | LOS A            | 0.1               | 0.8      | 0.36      | 0.90           | 0.36                | 30.7        |
| Approach                     |      |           | 24           | 4.3  | 24            | 4.3  | 0.032     | 8.9         | LOS A            | 0.1               | 0.8      | 0.36      | 0.90           | 0.36                | 32.7        |
| West: Argyle PI (W)          |      |           |              |      |               |      |           |             |                  |                   |          |           |                |                     |             |
| 10                           | L2   | All MCs   | 2            | 0.0  | 2             | 0.0  | 0.107     | 3.4         | LOS A            | 0.5               | 3.6      | 0.05      | 0.31           | 0.05                | 35.8        |
| 11                           | T1   | All MCs   | 49           | 6.4  | 49            | 6.4  | 0.107     | 0.0         | LOS A            | 0.5               | 3.6      | 0.05      | 0.31           | 0.05                | 37.4        |
| 12                           | R2   | All MCs   | 83           | 0.0  | 83            | 0.0  | 0.107     | 3.9         | LOS A            | 0.5               | 3.6      | 0.05      | 0.31           | 0.05                | 37.7        |
| Approach                     |      |           | 135          | 2.3  | 135           | 2.3  | 0.107     | 2.5         | NA               | 0.5               | 3.6      | 0.05      | 0.31           | 0.05                | 37.6        |
| All Vehicles                 |      |           | 745          | 2.4  | 745           | 2.4  | 0.414     | 4.5         | NA               | 2.4               | 16.9     | 0.27      | 0.49           | 0.33                | 36.2        |

Site Level of Service (LOS) Method: Delay (RTA NSW). Site LOS Method is specified in the Parameter Settings dialog (Options tab).

Vehicle movement LOS values are based on average delay per movement.

Minor Road Approach LOS values are based on average delay for all vehicle movements.

NA (TWSC): Level of Service is not defined for major road approaches or the intersection as a whole for Two-Way Sign Control (HCM LOS rule).

Two-Way Sign Control Capacity Model: SIDRA Standard.

Delay Model: SIDRA Standard (Control Delay: Geometric Delay is included).

Queue Model: SIDRA queue estimation methods are used for Back of Queue and Queue at Start of Gap.

Gap-Acceptance Capacity Formula: SIDRA Standard (Akçelik M3D).

HV (%) values are calculated for All Movement Classes of All Heavy Vehicle Model Designation.

Arrival Flows used in performance calculations are adjusted to include any Initial Queued Demand and Upstream Capacity Constraint effects.

---

**SIDRA INTERSECTION 9.1 | Copyright © 2000-2022 Akcelik and Associates Pty Ltd | sidrasolutions.com**

Organisation: AECOM AUSTRALIA PTY LTD | Licence: NETWORK / Enterprise Level 1 | Processed: Thursday, 13 July 2023 6:35:30 PM

Project: C:\Users\Yeung\AECOMANZ-NAC-Sydney Metro-Sydney Metro C&SW Operational Monitoring - General\400\_Technical\432\_Traffic Analysis\SIDRA Modelling\01 Models (Geometry Only)\Block 1\Rev1\\_Review\04 SM C&SW\_BGU (Block 1)\_PS.sip9

# CCG MOVEMENT SUMMARY

Common Control Group: CCG1 [TCS 4272]

Output produced by SIDRA INTERSECTION Version: 9.1.3.210

Network: BGU-N2 [BGU Network 2 (Network Folder: Block 1 Network - 2023 PM Peak)]

EQUISAT (Fixed-Time/SCATS) Coordinated Cycle Time = 90 seconds (CCG User-Given Phase Times)

| Vehicle Movement Performance (CCG)                                       |      |           |                       |     |                       |     |           |             |                  |                   |           |                |                     |             |      |
|--|------|-----------|-----------------------|-----|-----------------------|-----|-----------|-------------|------------------|-------------------|-----------|----------------|---------------------|-------------|------|
| Mov ID   | Turn | Mov Class | Demand Flows          |     | Arrival Flows         |     | Deg. Satn | Aver. Delay | Level of Service | 95% Back Of Queue | Prop. Que | Eff. Stop Rate | Aver. No. of Cycles | Aver. Speed |      |
|  |      |           | [ Total HV ]<br>veh/h | %   | [ Total HV ]<br>veh/h | %   |           |             |                  |                   |           |                |                     |             | v/c  |
| Site: BGU04 [BGU04 Pedestrian Mid-block Crossing at Kent St near Gas Ln] |      |           |                       |     |                       |     |           |             |                  |                   |           |                |                     |             |      |
| South: Kent St   |      |           |                       |     |                       |     |           |             |                  |                   |           |                |                     |             |      |
| 2  | T1   | All MCs   | 382                   | 0.6 | 382                   | 0.6 | 0.296     | 8.5         | LOS A            | 8.5               | 59.9      | 0.55           | 0.42                | 0.55        | 33.7 |
| Approach   |      |           | 382                   | 0.6 | 382                   | 0.6 | 0.296     | 8.5         | LOS A            | 8.5               | 59.9      | 0.55           | 0.42                | 0.55        | 33.7 |
| North: Kent St   |      |           |                       |     |                       |     |           |             |                  |                   |           |                |                     |             |      |
| 8  | T1   | All MCs   | 304                   | 1.0 | 304                   | 1.0 | 0.621     | 41.8        | LOS C            | 7.0               | 49.2      | 0.99           | 0.82                | 1.03        | 19.7 |
| Approach   |      |           | 304                   | 1.0 | 304                   | 1.0 | 0.621     | 41.8        | LOS C            | 7.0               | 49.2      | 0.99           | 0.82                | 1.03        | 19.7 |
| All Vehicles   |      |           | 686                   | 0.8 | 686                   | 0.8 | 0.621     | 23.3        | LOS B            | 8.5               | 59.9      | 0.75           | 0.59                | 0.76        | 26.0 |
| Site: BGU05 [BGU05 Kent St / Sydney Harbour Bridge (SHB) On-ramp ]       |      |           |                       |     |                       |     |           |             |                  |                   |           |                |                     |             |      |
| South: Kent St (S)   |      |           |                       |     |                       |     |           |             |                  |                   |           |                |                     |             |      |
| 2  | T1   | All MCs   | 239                   | 0.9 | 239                   | 0.9 | 0.236     | 3.4         | LOS A            | 2.4               | 17.2      | 0.25           | 0.21                | 0.25        | 34.3 |
| 3a   | R1   | All MCs   | 699                   | 4.2 | 699                   | 4.2 | *0.730    | 14.1        | LOS A            | 13.2              | 96.2      | 0.60           | 0.62                | 0.60        | 28.0 |
| Approach   |      |           | 938                   | 3.4 | 938                   | 3.4 | 0.730     | 11.4        | LOS A            | 13.2              | 96.2      | 0.51           | 0.52                | 0.51        | 28.9 |
| East: Clarence St (E)  |      |           |                       |     |                       |     |           |             |                  |                   |           |                |                     |             |      |
| 4  | L2   | All MCs   | 41                    | 5.1 | 41                    | 5.1 | 0.233     | 45.6        | LOS D            | 1.7               | 12.8      | 0.96           | 0.73                | 0.96        | 10.5 |
| 6  | R2   | All MCs   | 149                   | 0.0 | 149                   | 0.0 | *0.576    | 41.6        | LOS C            | 6.3               | 44.0      | 0.97           | 0.80                | 0.97        | 11.2 |
| Approach   |      |           | 191                   | 1.1 | 191                   | 1.1 | 0.576     | 42.4        | LOS C            | 6.3               | 44.0      | 0.96           | 0.79                | 0.96        | 11.1 |
| NorthEast: SHB On-ramp (NE)  |      |           |                       |     |                       |     |           |             |                  |                   |           |                |                     |             |      |
| 24a  | L1   | All MCs   | 161                   | 0.0 | 161                   | 0.0 | 0.190     | 37.6        | LOS C            | 6.2               | 16.7      | 0.93           | 0.73                | 0.93        | 18.6 |
| Approach   |      |           | 161                   | 0.0 | 161                   | 0.0 | 0.190     | 37.6        | LOS C            | 6.2               | 16.7      | 0.93           | 0.73                | 0.93        | 18.6 |
| North: Kent St (N)   |      |           |                       |     |                       |     |           |             |                  |                   |           |                |                     |             |      |
| 7b   | L3   | All MCs   | 165                   | 0.6 | 165                   | 0.6 | 0.576     | 49.1        | LOS D            | 7.5               | 52.6      | 1.00           | 0.85                | 1.00        | 11.2 |
| 8  | T1   | All MCs   | 127                   | 1.7 | 127                   | 1.7 | *0.747    | 37.1        | LOS C            | 5.5               | 39.0      | 0.96           | 0.79                | 1.01        | 5.5  |
| Approach   |      |           | 293                   | 1.1 | 293                   | 1.1 | 0.747     | 43.9        | LOS D            | 7.5               | 52.6      | 0.98           | 0.82                | 1.00        | 9.3  |
| All Vehicles   |      |           | 1582                  | 2.3 | 1582                  | 2.3 | 0.747     | 23.8        | LOS B            | 13.2              | 96.2      | 0.69           | 0.63                | 0.70        | 20.4 |

Site Level of Service (LOS) Method: Delay (RTA NSW). Site LOS Method is specified in the Network Data dialog (Override Site Data tab).

Vehicle movement LOS values are based on average delay per movement.

Intersection and Approach LOS values are based on average delay for all vehicle movements.

Delay Model: SIDRA Standard (Control Delay: Geometric Delay is included).

Gap-Acceptance Capacity Formula: SIDRA Standard (Akçelik M3D).

HV (%) values are calculated for All Movement Classes of All Heavy Vehicle Model Designation.

Arrival Flows used in performance calculations are adjusted to include any Initial Queued Demand and Upstream Capacity Constraint effects.

\* Critical Movement (Signal Timing)



| Pedestrian Movement Performance (CCG)                                    |          |           |             |                  |                                    |     |           |                |             |              |             |
|--|----------|-----------|-------------|------------------|------------------------------------|-----|-----------|----------------|-------------|--------------|-------------|
| Mov ID   | Crossing | Dem. Flow | Aver. Delay | Level of Service | AVERAGE BACK OF QUEUE [ Ped Dist ] |     | Prop. Que | Eff. Stop Rate | Travel Time | Travel Dist. | Aver. Speed |
|  |          | ped/h     | sec         |                  | ped                                | m   |           |                | sec         | m            | m/sec       |
| Site: BGU04 [BGU04 Pedestrian Mid-block Crossing at Kent St near Gas Ln] |          |           |             |                  |                                    |     |           |                |             |              |             |
| South: Kent St   |          |           |             |                  |                                    |     |           |                |             |              |             |
| P1   | Full     | 163       | 38.5        | LOS D            | 0.4                                | 0.4 | 0.93      | 0.93           | 205.2       | 200.0        | 0.97        |
| All Pedestrians  |          | 163       | 38.5        | LOS D            | 0.4                                | 0.4 | 0.93      | 0.93           | 205.2       | 200.0        | 0.97        |
| Site: BGU05 [BGU05 Kent St / Sydney Harbour Bridge (SHB) On-ramp ]       |          |           |             |                  |                                    |     |           |                |             |              |             |
| South: Kent St (S)   |          |           |             |                  |                                    |     |           |                |             |              |             |
| P1   | Full     | 262       | 35.1        | LOS D            | 0.6                                | 0.6 | 0.89      | 0.89           | 51.7        | 20.0         | 0.39        |
| All Pedestrians  |          | 262       | 35.1        | LOS D            | 0.6                                | 0.6 | 0.89      | 0.89           | 51.7        | 20.0         | 0.39        |

Level of Service (LOS) Method: SIDRA Pedestrian LOS Method (Based on Average Delay)  
 Pedestrian movement LOS values are based on average delay per pedestrian movement.  
 Intersection LOS value for Pedestrians is based on average delay for all pedestrian movements.

# MOVEMENT SUMMARY

Site: BGU06 [BGU06 Hickson Rd / Napoleon St / Sussex St  
(Site Folder: Block 1 - 2023 PM Peak)]

Output produced by SIDRA INTERSECTION Version: 9.1.3.210

Network: BGU-N2 [BGU  
Network 3 (Network Folder:  
Block 1 Network - 2023 PM  
Peak)]

TCS 4625

Site Category: (None)

Signals - EQUISAT (Fixed-Time/SCATS) Isolated Cycle Time = 75 seconds (Site User-Given Phase Times)

| Vehicle Movement Performance |      |           |                       |      |                       |      |           |             |                  |                   |               |           |                |                     |                  |
|------------------------------|------|-----------|-----------------------|------|-----------------------|------|-----------|-------------|------------------|-------------------|---------------|-----------|----------------|---------------------|------------------|
| Mov ID                       | Turn | Mov Class | Demand Flows          |      | Arrival Flows         |      | Deg. Satn | Aver. Delay | Level of Service | 95% Back Of Queue |               | Prop. Que | Eff. Stop Rate | Aver. No. of Cycles | Aver. Speed km/h |
|                              |      |           | [ Total HV ]<br>veh/h | %    | [ Total HV ]<br>veh/h | %    |           |             |                  | [ Veh. veh        | [ Dist ]<br>m |           |                |                     |                  |
| South: Sussex St (S)         |      |           |                       |      |                       |      |           |             |                  |                   |               |           |                |                     |                  |
| 2                            | T1   | All MCs   | 415                   | 1.5  | 415                   | 1.5  | 0.438     | 13.2        | LOS A            | 9.8               | 69.6          | 0.69      | 0.60           | 0.69                | 22.8             |
| 3                            | R2   | All MCs   | 97                    | 0.0  | 97                    | 0.0  | *0.308    | 22.2        | LOS B            | 2.6               | 18.0          | 0.84      | 0.74           | 0.84                | 20.5             |
| Approach                     |      |           | 512                   | 1.2  | 512                   | 1.2  | 0.438     | 14.9        | LOS B            | 9.8               | 69.6          | 0.72      | 0.63           | 0.72                | 22.2             |
| East: Napoleon St (E)        |      |           |                       |      |                       |      |           |             |                  |                   |               |           |                |                     |                  |
| 4                            | L2   | All MCs   | 99                    | 21.3 | 99                    | 21.3 | 0.214     | 24.7        | LOS B            | 2.7               | 22.7          | 0.78      | 0.72           | 0.78                | 14.2             |
| 6                            | R2   | All MCs   | 215                   | 5.9  | 215                   | 5.9  | *0.659    | 35.7        | LOS C            | 7.7               | 56.9          | 0.98      | 0.85           | 1.03                | 13.9             |
| Approach                     |      |           | 314                   | 10.7 | 314                   | 10.7 | 0.659     | 32.2        | LOS C            | 7.7               | 56.9          | 0.92      | 0.81           | 0.95                | 14.0             |
| North: Hickson Rd (N)        |      |           |                       |      |                       |      |           |             |                  |                   |               |           |                |                     |                  |
| 7                            | L2   | All MCs   | 151                   | 2.1  | 151                   | 2.1  | 0.270     | 25.8        | LOS B            | 4.2               | 30.1          | 0.80      | 0.74           | 0.80                | 16.9             |
| 8                            | T1   | All MCs   | 316                   | 4.0  | 316                   | 4.0  | *0.479    | 21.1        | LOS B            | 9.0               | 65.5          | 0.82      | 0.70           | 0.82                | 10.5             |
| Approach                     |      |           | 466                   | 3.4  | 466                   | 3.4  | 0.479     | 22.6        | LOS B            | 9.0               | 65.5          | 0.81      | 0.71           | 0.81                | 13.3             |
| West: Car Park Access (W)    |      |           |                       |      |                       |      |           |             |                  |                   |               |           |                |                     |                  |
| 10                           | L2   | All MCs   | 2                     | 0.0  | 2                     | 0.0  | 0.075     | 39.1        | LOS C            | 0.3               | 2.0           | 0.97      | 0.64           | 0.97                | 5.8              |
| 11                           | T1   | All MCs   | 27                    | 0.0  | 27                    | 0.0  | *0.358    | 40.4        | LOS C            | 1.4               | 9.9           | 0.99      | 0.70           | 0.99                | 9.1              |
| 12                           | R2   | All MCs   | 15                    | 0.0  | 15                    | 0.0  | 0.358     | 40.6        | LOS C            | 1.4               | 9.9           | 1.00      | 0.72           | 1.00                | 2.5              |
| Approach                     |      |           | 44                    | 0.0  | 44                    | 0.0  | 0.358     | 40.4        | LOS C            | 1.4               | 9.9           | 0.99      | 0.71           | 0.99                | 7.1              |
| All Vehicles                 |      |           | 1336                  | 4.2  | 1336                  | 4.2  | 0.659     | 22.5        | LOS B            | 9.8               | 69.6          | 0.81      | 0.70           | 0.82                | 16.2             |

Site Level of Service (LOS) Method: Delay (RTA NSW). Site LOS Method is specified in the Network Data dialog (Override Site Data tab).

Vehicle movement LOS values are based on average delay per movement.

Intersection and Approach LOS values are based on average delay for all vehicle movements.

Delay Model: SIDRA Standard (Control Delay: Geometric Delay is included).

Queue Model: SIDRA queue estimation methods are used for Back of Queue and Queue at Start of Green.

Gap-Acceptance Capacity Formula: SIDRA Standard (Akçelik M3D).

HV (%) values are calculated for All Movement Classes of All Heavy Vehicle Model Designation.

Arrival Flows used in performance calculations are adjusted to include any Initial Queued Demand and Upstream Capacity Constraint effects.

\* Critical Movement (Signal Timing)

| Pedestrian Movement Performance |          |           |             |                  |                       |        |           |                |             |              |             |
|---------------------------------|----------|-----------|-------------|------------------|-----------------------|--------|-----------|----------------|-------------|--------------|-------------|
| Mov ID                          | Crossing | Dem. Flow | Aver. Delay | Level of Service | AVERAGE BACK OF QUEUE |        | Prop. Que | Eff. Stop Rate | Travel Time | Travel Dist. | Aver. Speed |
|                                 |          | ped/h     | sec         |                  | [ Ped                 | Dist ] |           |                | sec         | m            | m/sec       |
|                                 |          |           |             |                  | ped                   | m      |           |                |             |              |             |
| South: Sussex St (S)            |          |           |             |                  |                       |        |           |                |             |              |             |
| P1                              | Full     | 81        | 24.9        | LOS C            | 0.1                   | 0.1    | 0.82      | 0.82           | 41.6        | 20.0         | 0.48        |
| East: Napoleon St (E)           |          |           |             |                  |                       |        |           |                |             |              |             |
| P2                              | Full     | 178       | 25.0        | LOS C            | 0.3                   | 0.3    | 0.82      | 0.82           | 41.7        | 20.0         | 0.48        |
| North: Hickson Rd (N)           |          |           |             |                  |                       |        |           |                |             |              |             |
| P3                              | Full     | 81        | 24.9        | LOS C            | 0.1                   | 0.1    | 0.82      | 0.82           | 41.6        | 20.0         | 0.48        |
| West: Car Park Access (W)       |          |           |             |                  |                       |        |           |                |             |              |             |
| P4                              | Full     | 127       | 30.1        | LOS D            | 0.2                   | 0.2    | 0.90      | 0.90           | 46.8        | 20.0         | 0.43        |
| All Pedestrians                 |          | 467       | 26.3        | LOS C            | 0.3                   | 0.3    | 0.84      | 0.84           | 43.0        | 20.0         | 0.46        |

Level of Service (LOS) Method: SIDRA Pedestrian LOS Method (Based on Average Delay)

Pedestrian movement LOS values are based on average delay per pedestrian movement.

Intersection LOS value for Pedestrians is based on average delay for all pedestrian movements.

**SIDRA INTERSECTION 9.1 | Copyright © 2000-2022 Akcelik and Associates Pty Ltd | sidrasolutions.com**

Organisation: AECOM AUSTRALIA PTY LTD | Licence: NETWORK / Enterprise Level 1 | Processed: Monday, 17 July 2023 11:23:46 AM

Project: C:\Users\YeungMAECOMANZ-NAC-Sydney Metro-Sydney Metro C&SW Operational Monitoring - General\400\_Technical\432\_Traffic Analysis\SIDRA Modelling\01 Models (Geometry Only)\Block 1\Rev1\_Review\04 SM C&SW\_BGU (Block 1)\_PS.sip9

# MOVEMENT SUMMARY

Site: BGU07 [BGU07 Margaret St / Kent St / Napoleon St (Site Folder: Block 1 - 2023 PM Peak)]

Output produced by SIDRA INTERSECTION Version: 9.1.3.210

Network: BGU-N2 [BGU Network 2 (Network Folder: Block 1 Network - 2023 PM Peak)]

TCS 308

Site Category: (None)

Signals - EQUISAT (Fixed-Time/SCATS) Coordinated Cycle Time = 90 seconds (Network Site User-Given Phase Times)

| Vehicle Movement Performance |      |           |              |      |               |      |           |             |                  |                   |        |           |                |                     |             |
|------------------------------|------|-----------|--------------|------|---------------|------|-----------|-------------|------------------|-------------------|--------|-----------|----------------|---------------------|-------------|
| Mov ID                       | Turn | Mov Class | Demand Flows |      | Arrival Flows |      | Deg. Satn | Aver. Delay | Level of Service | 95% Back Of Queue |        | Prop. Que | Eff. Stop Rate | Aver. No. of Cycles | Aver. Speed |
|                              |      |           | [ Total HV ] | %    | [ Total HV ]  | %    |           |             |                  | [ Veh. veh        | Dist ] |           |                |                     |             |
| South: Kent St (S)           |      |           |              |      |               |      |           |             |                  |                   |        |           |                |                     |             |
| 1a                           | L1   | All MCs   | 52           | 18.4 | 52            | 18.4 | *0.474    | 26.0        | LOS B            | 12.4              | 91.2   | 0.69      | 0.63           | 0.69                | 20.9        |
| 2                            | T1   | All MCs   | 695          | 4.1  | 695           | 4.1  | 0.474     | 20.1        | LOS B            | 12.4              | 91.2   | 0.77      | 0.67           | 0.77                | 8.6         |
| 3                            | R2   | All MCs   | 34           | 0.0  | 34            | 0.0  | 0.474     | 56.3        | LOS D            | 8.9               | 64.1   | 0.86      | 0.73           | 0.86                | 7.3         |
| Approach                     |      |           | 780          | 4.9  | 780           | 4.9  | 0.474     | 22.0        | LOS B            | 12.4              | 91.2   | 0.77      | 0.67           | 0.77                | 9.5         |
| East: Margaret St (E)        |      |           |              |      |               |      |           |             |                  |                   |        |           |                |                     |             |
| 4                            | L2   | All MCs   | 32           | 0.0  | 32            | 0.0  | 0.109     | 40.9        | LOS C            | 1.3               | 8.9    | 0.93      | 0.71           | 0.93                | 7.7         |
| 6a                           | R1   | All MCs   | 222          | 10.0 | 222           | 10.0 | 0.657     | 34.5        | LOS C            | 8.7               | 65.3   | 0.95      | 0.83           | 0.97                | 13.6        |
| 6                            | R2   | All MCs   | 56           | 1.9  | 56            | 1.9  | *0.657    | 36.5        | LOS C            | 8.7               | 65.3   | 0.95      | 0.83           | 0.97                | 5.8         |
| Approach                     |      |           | 309          | 7.5  | 309           | 7.5  | 0.657     | 35.5        | LOS C            | 8.7               | 65.3   | 0.95      | 0.82           | 0.96                | 11.9        |
| North: Kent St (N)           |      |           |              |      |               |      |           |             |                  |                   |        |           |                |                     |             |
| 7                            | L2   | All MCs   | 52           | 0.0  | 52            | 0.0  | 0.278     | 19.1        | LOS B            | 2.8               | 19.6   | 0.39      | 0.41           | 0.39                | 25.8        |
| 8                            | T1   | All MCs   | 281          | 0.4  | 281           | 0.4  | 0.278     | 27.4        | LOS B            | 6.9               | 18.5   | 0.74      | 0.63           | 0.74                | 17.1        |
| 9b                           | R3   | All MCs   | 28           | 0.0  | 28            | 0.0  | 0.096     | 7.3         | LOS A            | 0.1               | 0.9    | 0.11      | 0.54           | 0.11                | 31.7        |
| Approach                     |      |           | 361          | 0.3  | 361           | 0.3  | 0.278     | 24.6        | LOS B            | 6.9               | 19.6   | 0.64      | 0.59           | 0.64                | 18.7        |
| NorthWest: Napoleon St (NW)  |      |           |              |      |               |      |           |             |                  |                   |        |           |                |                     |             |
| 27b                          | L3   | All MCs   | 187          | 2.2  | 187           | 2.2  | 0.327     | 9.2         | LOS A            | 4.3               | 30.6   | 0.56      | 0.67           | 0.56                | 24.1        |
| 27a                          | L1   | All MCs   | 58           | 0.0  | 58            | 0.0  | 0.327     | 20.9        | LOS B            | 4.3               | 30.6   | 0.56      | 0.67           | 0.56                | 24.1        |
| Approach                     |      |           | 245          | 1.7  | 245           | 1.7  | 0.327     | 11.9        | LOS A            | 4.3               | 30.6   | 0.56      | 0.67           | 0.56                | 24.1        |
| All Vehicles                 |      |           | 1696         | 3.9  | 1696          | 3.9  | 0.657     | 23.6        | LOS B            | 12.4              | 91.2   | 0.75      | 0.68           | 0.75                | 14.2        |

Site Level of Service (LOS) Method: Delay (RTA NSW). Site LOS Method is specified in the Network Data dialog (Override Site Data tab).

Vehicle movement LOS values are based on average delay per movement.

Intersection and Approach LOS values are based on average delay for all vehicle movements.

Delay Model: SIDRA Standard (Control Delay: Geometric Delay is included).

Queue Model: SIDRA queue estimation methods are used for Back of Queue and Queue at Start of Green.

Gap-Acceptance Capacity Formula: SIDRA Standard (Akçelik M3D).

HV (%) values are calculated for All Movement Classes of All Heavy Vehicle Model Designation.

Arrival Flows used in performance calculations are adjusted to include any Initial Queued Demand and Upstream Capacity Constraint effects.

\* Critical Movement (Signal Timing)

| Pedestrian Movement Performance |          |           |             |                  |                       |        |           |                |             |              |             |
|---------------------------------|----------|-----------|-------------|------------------|-----------------------|--------|-----------|----------------|-------------|--------------|-------------|
| Mov ID                          | Crossing | Dem. Flow | Aver. Delay | Level of Service | AVERAGE BACK OF QUEUE |        | Prop. Que | Eff. Stop Rate | Travel Time | Travel Dist. | Aver. Speed |
|                                 |          | ped/h     | sec         |                  | [ Ped                 | Dist ] |           |                | sec         | m            | m/sec       |
|                                 |          |           |             |                  | ped                   | m      |           |                |             |              |             |
| South: Kent St (S)              |          |           |             |                  |                       |        |           |                |             |              |             |
| P1                              | Full     | 882       | 33.3        | LOS D            | 2.0                   | 2.0    | 0.88      | 0.88           | 50.0        | 20.0         | 0.40        |
| East: Margaret St (E)           |          |           |             |                  |                       |        |           |                |             |              |             |
| P2                              | Full     | 144       | 36.7        | LOS D            | 0.3                   | 0.3    | 0.91      | 0.91           | 53.3        | 20.0         | 0.37        |
| North: Kent St (N)              |          |           |             |                  |                       |        |           |                |             |              |             |
| P3                              | Full     | 298       | 31.6        | LOS D            | 0.6                   | 0.6    | 0.84      | 0.84           | 48.3        | 20.0         | 0.41        |
| NorthWest: Napoleon St (NW)     |          |           |             |                  |                       |        |           |                |             |              |             |
| P7                              | Full     | 597       | 32.0        | LOS D            | 1.3                   | 1.3    | 0.85      | 0.85           | 198.7       | 200.0        | 1.01        |
| All Pedestrians                 |          | 1921      | 32.9        | LOS D            | 2.0                   | 2.0    | 0.87      | 0.87           | 96.2        | 75.9         | 0.79        |

Level of Service (LOS) Method: SIDRA Pedestrian LOS Method (Based on Average Delay)

Pedestrian movement LOS values are based on average delay per pedestrian movement.

Intersection LOS value for Pedestrians is based on average delay for all pedestrian movements.

**SIDRA INTERSECTION 9.1 | Copyright © 2000-2022 Akcelik and Associates Pty Ltd | sidrasolutions.com**

Organisation: AECOM AUSTRALIA PTY LTD | Licence: NETWORK / Enterprise Level 1 | Processed: Monday, 17 July 2023 11:58:39 AM

Project: C:\Users\YeungMA\AECOM\ANZ-NAC-Sydney Metro-Sydney Metro C&SW Operational Monitoring - General\400\_Technical\432\_Traffic Analysis\SIDRA Modelling\01 Models (Geometry Only)\Block 1\Rev1\_Review\04 SM C&SW\_BGU (Block 1)\_PS.sip9

# MOVEMENT SUMMARY

Site: BGU08 [BGU08 Margaret St / Clarence St (Site Folder: Block 1 - 2023 PM Peak)]

Output produced by SIDRA INTERSECTION Version: 9.1.3.210

Network: BGU-N2 [BGU Network 2 (Network Folder: Block 1 Network - 2023 PM Peak)]

TCS 319

Site Category: NA

Signals - EQUISAT (Fixed-Time/SCATS) Coordinated Cycle Time = 90 seconds (Network Site User-Given Phase Times)

| Vehicle Movement Performance |      |           |              |      |               |      |           |             |                  |                   |        |           |                |                     |             |
|------------------------------|------|-----------|--------------|------|---------------|------|-----------|-------------|------------------|-------------------|--------|-----------|----------------|---------------------|-------------|
| Mov ID                       | Turn | Mov Class | Demand Flows |      | Arrival Flows |      | Deg. Satn | Aver. Delay | Level of Service | 95% Back Of Queue |        | Prop. Que | Eff. Stop Rate | Aver. No. of Cycles | Aver. Speed |
|                              |      |           | [ Total HV ] | %    | [ Total HV ]  | %    |           |             |                  | [ Veh. veh        | Dist ] |           |                |                     |             |
|                              |      |           | veh/h        | %    | veh/h         | %    | v/c       | sec         |                  |                   | m      |           |                |                     | km/h        |
| South: Clarence St (S)       |      |           |              |      |               |      |           |             |                  |                   |        |           |                |                     |             |
| 1                            | L2   | All MCs   | 31           | 6.9  | 31            | 6.9  | *0.527    | 42.7        | LOS D            | 10.9              | 76.8   | 0.88      | 0.76           | 0.88                | 13.5        |
| 2                            | T1   | All MCs   | 754          | 20.3 | 754           | 20.3 | 0.527     | 26.2        | LOS B            | 12.2              | 85.6   | 0.85      | 0.72           | 0.85                | 17.1        |
| 3                            | R2   | All MCs   | 23           | 0.0  | 23            | 0.0  | 0.259     | 32.2        | LOS C            | 3.0               | 33.7   | 0.78      | 0.66           | 0.78                | 14.5        |
| Approach                     |      |           | 807          | 19.2 | 807           | 19.2 | 0.527     | 27.0        | LOS B            | 12.2              | 85.6   | 0.85      | 0.72           | 0.85                | 16.9        |
| East: Margaret St (E)        |      |           |              |      |               |      |           |             |                  |                   |        |           |                |                     |             |
| 5                            | T1   | All MCs   | 259          | 8.9  | 259           | 8.9  | 0.389     | 13.5        | LOS A            | 5.7               | 43.2   | 0.65      | 0.57           | 0.65                | 11.3        |
| 6                            | R2   | All MCs   | 101          | 68.8 | 101           | 68.8 | *0.389    | 18.9        | LOS B            | 3.6               | 36.5   | 0.77      | 0.72           | 0.77                | 14.1        |
| Approach                     |      |           | 360          | 25.7 | 360           | 25.7 | 0.389     | 15.0        | LOS B            | 5.7               | 43.2   | 0.68      | 0.61           | 0.68                | 12.4        |
| West: Margaret St (W)        |      |           |              |      |               |      |           |             |                  |                   |        |           |                |                     |             |
| 10                           | L2   | All MCs   | 92           | 2.3  | 92            | 2.3  | *0.516    | 47.3        | LOS D            | 6.5               | 46.1   | 0.99      | 0.80           | 0.99                | 7.8         |
| 11                           | T1   | All MCs   | 61           | 0.0  | 61            | 0.0  | 0.516     | 34.4        | LOS C            | 6.5               | 46.1   | 0.99      | 0.80           | 0.99                | 4.3         |
| Approach                     |      |           | 153          | 1.4  | 153           | 1.4  | 0.516     | 42.2        | LOS C            | 6.5               | 46.1   | 0.99      | 0.80           | 0.99                | 6.5         |
| All Vehicles                 |      |           | 1320         | 18.9 | 1320          | 18.9 | 0.527     | 25.5        | LOS B            | 12.2              | 85.6   | 0.82      | 0.70           | 0.82                | 14.7        |

Site Level of Service (LOS) Method: Delay (RTA NSW). Site LOS Method is specified in the Network Data dialog (Override Site Data tab).

Vehicle movement LOS values are based on average delay per movement.

Intersection and Approach LOS values are based on average delay for all vehicle movements.

Delay Model: SIDRA Standard (Control Delay: Geometric Delay is included).

Queue Model: SIDRA queue estimation methods are used for Back of Queue and Queue at Start of Green.

Gap-Acceptance Capacity Formula: SIDRA Standard (Akçelik M3D).

HV (%) values are calculated for All Movement Classes of All Heavy Vehicle Model Designation.

Arrival Flows used in performance calculations are adjusted to include any Initial Queued Demand and Upstream Capacity Constraint effects.

\* Critical Movement (Signal Timing)

| Pedestrian Movement Performance |          |           |             |                  |                       |        |           |                |             |              |             |
|---------------------------------|----------|-----------|-------------|------------------|-----------------------|--------|-----------|----------------|-------------|--------------|-------------|
| Mov ID                          | Crossing | Dem. Flow | Aver. Delay | Level of Service | AVERAGE BACK OF QUEUE |        | Prop. Que | Eff. Stop Rate | Travel Time | Travel Dist. | Aver. Speed |
|                                 |          | ped/h     | sec         |                  | [ Ped                 | Dist ] |           |                | sec         | m            | m/sec       |
|                                 |          |           |             |                  | ped                   | m      |           |                |             |              |             |
| South: Clarence St (S)          |          |           |             |                  |                       |        |           |                |             |              |             |
| P1                              | Full     | 1321      | 39.5        | LOS D            | 3.3                   | 3.3    | 0.96      | 0.96           | 56.2        | 20.0         | 0.36        |
| East: Margaret St (E)           |          |           |             |                  |                       |        |           |                |             |              |             |
| P2                              | Full     | 293       | 37.8        | LOS D            | 0.7                   | 0.7    | 0.92      | 0.92           | 54.5        | 20.0         | 0.37        |
| North: Clarence St (N)          |          |           |             |                  |                       |        |           |                |             |              |             |
| P3                              | Full     | 747       | 36.7        | LOS D            | 1.8                   | 1.8    | 0.92      | 0.92           | 53.4        | 20.0         | 0.37        |
| West: Margaret St (W)           |          |           |             |                  |                       |        |           |                |             |              |             |
| P4                              | Full     | 711       | 33.9        | LOS D            | 1.6                   | 1.6    | 0.88      | 0.88           | 50.6        | 20.0         | 0.40        |
| All Pedestrians                 |          | 3072      | 37.4        | LOS D            | 3.3                   | 3.3    | 0.93      | 0.93           | 54.1        | 20.0         | 0.37        |

Level of Service (LOS) Method: SIDRA Pedestrian LOS Method (Based on Average Delay)

Pedestrian movement LOS values are based on average delay per pedestrian movement.

Intersection LOS value for Pedestrians is based on average delay for all pedestrian movements.

**SIDRA INTERSECTION 9.1 | Copyright © 2000-2022 Akcelik and Associates Pty Ltd | sidrasolutions.com**

Organisation: AECOM AUSTRALIA PTY LTD | Licence: NETWORK / Enterprise Level 1 | Processed: Monday, 17 July 2023 11:58:39 AM

Project: C:\Users\YeungMA\AECOM\ANZ-NAC-Sydney Metro-Sydney Metro C&SW Operational Monitoring - General\400\_Technical\432\_Traffic Analysis\SIDRA Modelling\01 Models (Geometry Only)\Block 1\Rev1\_Review\04 SM C&SW\_BGU (Block 1)\_PS.sip9

# MOVEMENT SUMMARY

Site: BGU09 [BGU09 Margaret St / York St (Site Folder: Block 1 - 2023 PM Peak)]

Output produced by SIDRA INTERSECTION Version: 9.1.3.210

Network: BGU-N2 [BGU Network 2 (Network Folder: Block 1 Network - 2023 PM Peak)]

TCS 3042

Site Category: NA

Signals - EQUISAT (Fixed-Time/SCATS) Isolated Cycle Time = 90 seconds (Site User-Given Phase Times)

| Vehicle Movement Performance |      |           |                       |      |                       |      |           |             |                  |                   |               |           |                |                     |             |
|------------------------------|------|-----------|-----------------------|------|-----------------------|------|-----------|-------------|------------------|-------------------|---------------|-----------|----------------|---------------------|-------------|
| Mov ID                       | Turn | Mov Class | Demand Flows          |      | Arrival Flows         |      | Deg. Satn | Aver. Delay | Level of Service | 95% Back Of Queue |               | Prop. Que | Eff. Stop Rate | Aver. No. of Cycles | Aver. Speed |
|                              |      |           | [ Total HV ]<br>veh/h | %    | [ Total HV ]<br>veh/h | %    |           |             |                  | [ Veh. veh        | [ Dist ]<br>m |           |                |                     |             |
| East: Margaret St (E)        |      |           |                       |      |                       |      |           |             |                  |                   |               |           |                |                     |             |
| 4                            | L2   | All MCs   | 105                   | 1.0  | 105                   | 1.0  | 0.322     | 39.1        | LOS C            | 4.1               | 29.2          | 0.91      | 0.76           | 0.91                | 13.4        |
| 5                            | T1   | All MCs   | 114                   | 60.2 | 114                   | 60.2 | 0.300     | 26.0        | LOS B            | 3.9               | 41.2          | 0.80      | 0.65           | 0.80                | 8.7         |
| Approach                     |      |           | 219                   | 31.7 | 219                   | 31.7 | 0.322     | 32.3        | LOS C            | 4.1               | 41.2          | 0.86      | 0.71           | 0.86                | 11.7        |
| North: York St (N)           |      |           |                       |      |                       |      |           |             |                  |                   |               |           |                |                     |             |
| 7                            | L2   | All MCs   | 1                     | 0.0  | 1                     | 0.0  | 0.000     | 17.9        | LOS B            | 0.0               | 0.1           | 0.60      | 0.48           | 0.60                | 14.7        |
| 8                            | T1   | All MCs   | 818                   | 23.8 | 818                   | 23.8 | 0.318     | 12.1        | LOS A            | 6.6               | 55.4          | 0.59      | 0.51           | 0.59                | 25.4        |
| 9                            | R2   | All MCs   | 245                   | 8.6  | 245                   | 8.6  | *0.296    | 18.7        | LOS B            | 6.4               | 48.2          | 0.64      | 0.74           | 0.64                | 11.2        |
| Approach                     |      |           | 1064                  | 20.3 | 1064                  | 20.3 | 0.318     | 13.6        | LOS A            | 6.6               | 55.4          | 0.60      | 0.56           | 0.60                | 22.7        |
| West: Margaret St (W)        |      |           |                       |      |                       |      |           |             |                  |                   |               |           |                |                     |             |
| 12                           | R2   | All MCs   | 82                    | 0.0  | 82                    | 0.0  | *0.420    | 43.9        | LOS D            | 3.5               | 24.5          | 0.96      | 0.77           | 0.96                | 11.4        |
| Approach                     |      |           | 82                    | 0.0  | 82                    | 0.0  | 0.420     | 43.9        | LOS D            | 3.5               | 24.5          | 0.96      | 0.77           | 0.96                | 11.4        |
| All Vehicles                 |      |           | 1365                  | 20.9 | 1365                  | 20.9 | 0.420     | 18.4        | LOS B            | 6.6               | 55.4          | 0.66      | 0.60           | 0.66                | 19.2        |

Site Level of Service (LOS) Method: Delay (RTA NSW). Site LOS Method is specified in the Network Data dialog (Override Site Data tab).

Vehicle movement LOS values are based on average delay per movement.

Intersection and Approach LOS values are based on average delay for all vehicle movements.

Delay Model: SIDRA Standard (Control Delay: Geometric Delay is included).

Queue Model: SIDRA queue estimation methods are used for Back of Queue and Queue at Start of Green.

Gap-Acceptance Capacity Formula: SIDRA Standard (Akçelik M3D).

HV (%) values are calculated for All Movement Classes of All Heavy Vehicle Model Designation.

Arrival Flows used in performance calculations are adjusted to include any Initial Queued Demand and Upstream Capacity Constraint effects.

\* Critical Movement (Signal Timing)



| Pedestrian Movement Performance |          |           |             |                  |                       |        |           |                |             |              |             |
|---------------------------------|----------|-----------|-------------|------------------|-----------------------|--------|-----------|----------------|-------------|--------------|-------------|
| Mov ID                          | Crossing | Dem. Flow | Aver. Delay | Level of Service | AVERAGE BACK OF QUEUE |        | Prop. Que | Eff. Stop Rate | Travel Time | Travel Dist. | Aver. Speed |
|                                 |          | ped/h     | sec         |                  | [ Ped                 | Dist ] |           |                | sec         | m            | m/sec       |
|                                 |          |           |             |                  | ped                   | m      |           |                |             |              |             |
| South: York St (S)              |          |           |             |                  |                       |        |           |                |             |              |             |
| P1                              | Full     | 1195      | 34.7        | LOS D            | 2.8                   | 2.8    | 0.90      | 0.90           | 51.3        | 20.0         | 0.39        |
| East: Margaret St (E)           |          |           |             |                  |                       |        |           |                |             |              |             |
| P2                              | Full     | 1138      | 34.6        | LOS D            | 2.6                   | 2.6    | 0.90      | 0.90           | 51.2        | 20.0         | 0.39        |
| North: York St (N)              |          |           |             |                  |                       |        |           |                |             |              |             |
| P3                              | Full     | 666       | 32.1        | LOS D            | 1.5                   | 1.5    | 0.86      | 0.86           | 48.8        | 20.0         | 0.41        |
| West: Margaret St (W)           |          |           |             |                  |                       |        |           |                |             |              |             |
| P4                              | Full     | 541       | 36.4        | LOS D            | 1.3                   | 1.3    | 0.91      | 0.91           | 53.0        | 20.0         | 0.38        |
| All Pedestrians                 |          | 3540      | 34.4        | LOS D            | 2.8                   | 2.8    | 0.89      | 0.89           | 51.1        | 20.0         | 0.39        |

Level of Service (LOS) Method: SIDRA Pedestrian LOS Method (Based on Average Delay)

Pedestrian movement LOS values are based on average delay per pedestrian movement.

Intersection LOS value for Pedestrians is based on average delay for all pedestrian movements.

**SIDRA INTERSECTION 9.1 | Copyright © 2000-2022 Akcelik and Associates Pty Ltd | sidrasolutions.com**

Organisation: AECOM AUSTRALIA PTY LTD | Licence: NETWORK / Enterprise Level 1 | Processed: Monday, 17 July 2023 11:58:39 AM

Project: C:\Users\YeungMA\AECOM\ANZ-NAC-Sydney Metro-Sydney Metro C&SW Operational Monitoring - General\400\_Technical\432\_Traffic Analysis\SIDRA Modelling\01 Models (Geometry Only)\Block 1\Rev1\_Review\04 SM C&SW\_BGU (Block 1)\_PS.sip9

# MOVEMENT SUMMARY

 Site: BGU10 [BGU10 Pedestrian Mid-block Crossing at Sussex St under Exchange PI (Site Folder: Block 1 - 2023 PM Peak)]

 Network: BGU-N2 [BGU Network 3 (Network Folder: Block 1 Network - 2023 PM Peak)]

Output produced by SIDRA INTERSECTION Version: 9.1.3.210

TCS 3939 (?)

Site Category: (None)

Pedestrian Crossing (Signalised) - EQUISAT (Fixed-Time/SCATS) Isolated Cycle Time = 70 seconds (Site User-Given Phase Times)

| Vehicle Movement Performance |      |           |              |     |               |     |           |             |                  |                   |          |           |                |                     |             |
|------------------------------|------|-----------|--------------|-----|---------------|-----|-----------|-------------|------------------|-------------------|----------|-----------|----------------|---------------------|-------------|
| Mov ID                       | Turn | Mov Class | Demand Flows |     | Arrival Flows |     | Deg. Satn | Aver. Delay | Level of Service | 95% Back Of Queue |          | Prop. Que | Eff. Stop Rate | Aver. No. of Cycles | Aver. Speed |
|                              |      |           | [ Total HV ] | %   | [ Total HV ]  | %   |           |             |                  | [ Veh. veh        | Dist ] m |           |                |                     |             |
| South: Sussex St (S)         |      |           |              |     |               |     |           |             |                  |                   |          |           |                |                     |             |
| 2                            | T1   | All MCs   | 561          | 1.1 | 561           | 1.1 | *0.196    | 2.9         | LOS A            | 2.8               | 20.1     | 0.32      | 0.27           | 0.32                | 33.0        |
| Approach                     |      |           | 561          | 1.1 | 561           | 1.1 | 0.196     | 2.9         | LOS A            | 2.8               | 20.1     | 0.32      | 0.27           | 0.32                | 33.0        |
| North: Sussex St (N)         |      |           |              |     |               |     |           |             |                  |                   |          |           |                |                     |             |
| 8                            | T1   | All MCs   | 495          | 7.0 | 495           | 7.0 | 0.183     | 2.8         | LOS A            | 2.5               | 18.4     | 0.32      | 0.27           | 0.32                | 31.9        |
| Approach                     |      |           | 495          | 7.0 | 495           | 7.0 | 0.183     | 2.8         | LOS A            | 2.5               | 18.4     | 0.32      | 0.27           | 0.32                | 31.9        |
| All Vehicles                 |      |           | 1056         | 3.9 | 1056          | 3.9 | 0.196     | 2.9         | LOS A            | 2.8               | 20.1     | 0.32      | 0.27           | 0.32                | 32.5        |

Site Level of Service (LOS) Method: Delay (RTA NSW). Site LOS Method is specified in the Network Data dialog (Override Site Data tab).

Vehicle movement LOS values are based on average delay per movement.

Intersection and Approach LOS values are based on average delay for all vehicle movements.

Delay Model: SIDRA Standard (Control Delay: Geometric Delay is included).

Queue Model: SIDRA queue estimation methods are used for Back of Queue and Queue at Start of Green.

Gap-Acceptance Capacity Formula: SIDRA Standard (Akçelik M3D).

HV (%) values are calculated for All Movement Classes of All Heavy Vehicle Model Designation.

Arrival Flows used in performance calculations are adjusted to include any Initial Queued Demand and Upstream Capacity Constraint effects.

\* Critical Movement (Signal Timing)

| Pedestrian Movement Performance |          |           |             |                  |                       |        |           |                |             |              |             |
|---------------------------------|----------|-----------|-------------|------------------|-----------------------|--------|-----------|----------------|-------------|--------------|-------------|
| Mov ID                          | Crossing | Dem. Flow | Aver. Delay | Level of Service | AVERAGE BACK OF QUEUE |        | Prop. Que | Eff. Stop Rate | Travel Time | Travel Dist. | Aver. Speed |
|                                 |          | ped/h     | sec         |                  | [ Ped                 | Dist ] |           |                | sec         | m            | m/sec       |
|                                 |          |           |             |                  | ped                   | m      |           |                |             |              |             |
| South: Sussex St (S)            |          |           |             |                  |                       |        |           |                |             |              |             |
| P1                              | Full     | 481       | 24.5        | LOS C            | 0.8                   | 0.8    | 0.85      | 0.85           | 41.2        | 20.0         | 0.49        |
| All Pedestrians                 |          | 481       | 24.5        | LOS C            | 0.8                   | 0.8    | 0.85      | 0.85           | 41.2        | 20.0         | 0.49        |

Level of Service (LOS) Method: SIDRA Pedestrian LOS Method (Based on Average Delay)

Pedestrian movement LOS values are based on average delay per pedestrian movement.

Intersection LOS value for Pedestrians is based on average delay for all pedestrian movements.

---

**SIDRA INTERSECTION 9.1 | Copyright © 2000-2022 Akcelik and Associates Pty Ltd | sidrasolutions.com**

Organisation: AECOM AUSTRALIA PTY LTD | Licence: NETWORK / Enterprise Level 1 | Processed: Monday, 17 July 2023 11:23:46 AM

Project: C:\Users\YeungM\AECOM\ANZ-NAC-Sydney Metro-Sydney Metro C&SW Operational Monitoring - General\400\_Technical\432\_Traffic Analysis\SIDRA Modelling\01 Models (Geometry Only)\Block 1\Rev1\\_Review\04 SM C&SW\_BGU (Block 1)\_PS.sip9

# MOVEMENT SUMMARY

 Site: **BGU11 [BGU11 Pedestrian Mid-block Crossing at Kent St near Margaret St (Site Folder: Block 1 - 2023 PM Peak)]**

Output produced by SIDRA INTERSECTION Version: 9.1.3.210

 Network: **BGU-N2 [BGU Network 3 (Network Folder: Block 1 Network - 2023 PM Peak)]**

TCS 4109

Site Category: (None)

Pedestrian Crossing (Signalised) - EQUISAT (Fixed-Time/SCATS) Isolated Cycle Time = 45 seconds (Site User-Given Phase Times)

| Vehicle Movement Performance |      |           |              |     |               |     |           |             |                  |                   |          |           |                |                     |             |
|------------------------------|------|-----------|--------------|-----|---------------|-----|-----------|-------------|------------------|-------------------|----------|-----------|----------------|---------------------|-------------|
| Mov ID                       | Turn | Mov Class | Demand Flows |     | Arrival Flows |     | Deg. Satn | Aver. Delay | Level of Service | 95% Back Of Queue |          | Prop. Que | Eff. Stop Rate | Aver. No. of Cycles | Aver. Speed |
|                              |      |           | [ Total HV ] | %   | [ Total HV ]  | %   |           |             |                  | [ Veh. veh        | Dist ] m |           |                |                     |             |
| South: Kent St (S)           |      |           |              |     |               |     |           |             |                  |                   |          |           |                |                     |             |
| 2                            | T1   | All MCs   | 718          | 5.4 | 718           | 5.4 | *0.402    | 9.7         | LOS A            | 4.9               | 36.1     | 0.72      | 0.60           | 0.72                | 22.3        |
| Approach                     |      |           | 718          | 5.4 | 718           | 5.4 | 0.402     | 9.7         | LOS A            | 4.9               | 36.1     | 0.72      | 0.60           | 0.72                | 22.3        |
| North: Kent St (N)           |      |           |              |     |               |     |           |             |                  |                   |          |           |                |                     |             |
| 8                            | T1   | All MCs   | 313          | 0.3 | 313           | 0.3 | 0.185     | 8.5         | LOS A            | 2.1               | 15.0     | 0.64      | 0.51           | 0.64                | 15.3        |
| Approach                     |      |           | 313          | 0.3 | 313           | 0.3 | 0.185     | 8.5         | LOS A            | 2.1               | 15.0     | 0.64      | 0.51           | 0.64                | 15.3        |
| All Vehicles                 |      |           | 1031         | 3.9 | 1031          | 3.9 | 0.402     | 9.4         | LOS A            | 4.9               | 36.1     | 0.70      | 0.57           | 0.70                | 20.8        |

Site Level of Service (LOS) Method: Delay (RTA NSW). Site LOS Method is specified in the Network Data dialog (Override Site Data tab).

Vehicle movement LOS values are based on average delay per movement.

Intersection and Approach LOS values are based on average delay for all vehicle movements.

Delay Model: SIDRA Standard (Control Delay: Geometric Delay is included).

Queue Model: SIDRA queue estimation methods are used for Back of Queue and Queue at Start of Green.

Gap-Acceptance Capacity Formula: SIDRA Standard (Akçelik M3D).

HV (%) values are calculated for All Movement Classes of All Heavy Vehicle Model Designation.

Arrival Flows used in performance calculations are adjusted to include any Initial Queued Demand and Upstream Capacity Constraint effects.

\* Critical Movement (Signal Timing)

| Pedestrian Movement Performance |          |           |             |                  |                       |        |           |                |             |              |             |
|---------------------------------|----------|-----------|-------------|------------------|-----------------------|--------|-----------|----------------|-------------|--------------|-------------|
| Mov ID                          | Crossing | Dem. Flow | Aver. Delay | Level of Service | AVERAGE BACK OF QUEUE |        | Prop. Que | Eff. Stop Rate | Travel Time | Travel Dist. | Aver. Speed |
|                                 |          | ped/h     | sec         |                  | [ Ped                 | Dist ] |           |                | sec         | m            | m/sec       |
|                                 |          |           |             |                  | ped                   | m      |           |                |             |              |             |
| South: Kent St (S)              |          |           |             |                  |                       |        |           |                |             |              |             |
| P1                              | Full     | 975       | 12.6        | LOS B            | 1.0                   | 1.0    | 0.76      | 0.76           | 29.3        | 20.0         | 0.68        |
| All Pedestrians                 |          | 975       | 12.6        | LOS B            | 1.0                   | 1.0    | 0.76      | 0.76           | 29.3        | 20.0         | 0.68        |

Level of Service (LOS) Method: SIDRA Pedestrian LOS Method (Based on Average Delay)  
 Pedestrian movement LOS values are based on average delay per pedestrian movement.  
 Intersection LOS value for Pedestrians is based on average delay for all pedestrian movements.

---

**SIDRA INTERSECTION 9.1 | Copyright © 2000-2022 Akcelik and Associates Pty Ltd | sidrasolutions.com**  
 Organisation: AECOM AUSTRALIA PTY LTD | Licence: NETWORK / Enterprise Level 1 | Processed: Monday, 17 July 2023 11:23:46 AM  
 Project: C:\Users\YeungM\AECOM\ANZ-NAC-Sydney Metro-Sydney Metro C&SW Operational Monitoring - General\400\_Technical\432\_Traffic Analysis\SIDRA Modelling\01 Models (Geometry Only)\Block 1\Rev1\\_Review\04 SM C&SW\_BGU (Block 1)\_PS.sip9

# MOVEMENT SUMMARY

Site: BGU12 [BGU12 Sussex St / Erskine St (Site Folder: Block 1 - 2023 PM Peak)]

Output produced by SIDRA INTERSECTION Version: 9.1.3.210

Network: BGU-N2 [BGU Network 3 (Network Folder: Block 1 Network - 2023 PM Peak)]

TCS 310

Site Category: (None)

Signals - EQUISAT (Fixed-Time/SCATS) Coordinated Cycle Time = 90 seconds (Network Site User-Given Phase Times)

| Vehicle Movement Performance |      |           |              |      |               |      |           |             |                  |                   |        |           |                |                     |             |
|------------------------------|------|-----------|--------------|------|---------------|------|-----------|-------------|------------------|-------------------|--------|-----------|----------------|---------------------|-------------|
| Mov ID                       | Turn | Mov Class | Demand Flows |      | Arrival Flows |      | Deg. Satn | Aver. Delay | Level of Service | 95% Back Of Queue |        | Prop. Que | Eff. Stop Rate | Aver. No. of Cycles | Aver. Speed |
|                              |      |           | [ Total HV ] | %    | [ Total HV ]  | %    |           |             |                  | [ Veh. veh        | Dist ] |           |                |                     |             |
|                              |      |           | veh/h        | %    | veh/h         | %    | v/c       | sec         |                  | veh               | m      |           |                |                     | km/h        |
| South: Sussex St (S)         |      |           |              |      |               |      |           |             |                  |                   |        |           |                |                     |             |
| 1                            | L2   | All MCs   | 63           | 0.0  | 63            | 0.0  | *0.466    | 39.9        | LOS C            | 8.0               | 56.4   | 0.90      | 0.76           | 0.90                | 14.7        |
| 2                            | T1   | All MCs   | 399          | 0.5  | 399           | 0.5  | 0.466     | 29.5        | LOS C            | 9.3               | 65.1   | 0.89      | 0.75           | 0.89                | 15.3        |
| Approach                     |      |           | 462          | 0.5  | 462           | 0.5  | 0.466     | 30.9        | LOS C            | 9.3               | 65.1   | 0.89      | 0.75           | 0.89                | 15.2        |
| East: Erskine St (E)         |      |           |              |      |               |      |           |             |                  |                   |        |           |                |                     |             |
| 4                            | L2   | All MCs   | 394          | 1.1  | 394           | 1.1  | 0.449     | 12.7        | LOS A            | 7.8               | 54.8   | 0.48      | 0.66           | 0.48                | 25.7        |
| 5                            | T1   | All MCs   | 118          | 6.3  | 118           | 6.3  | 0.245     | 2.4         | LOS A            | 1.1               | 7.7    | 0.15      | 0.24           | 0.15                | 26.9        |
| 6                            | R2   | All MCs   | 55           | 1.9  | 55            | 1.9  | 0.245     | 6.7         | LOS A            | 1.1               | 7.7    | 0.15      | 0.24           | 0.15                | 26.9        |
| Approach                     |      |           | 566          | 2.2  | 566           | 2.2  | 0.449     | 10.0        | LOS A            | 7.8               | 54.8   | 0.38      | 0.53           | 0.38                | 25.9        |
| North: Sussex St (N)         |      |           |              |      |               |      |           |             |                  |                   |        |           |                |                     |             |
| 7                            | L2   | All MCs   | 29           | 42.9 | 29            | 42.9 | 0.073     | 26.6        | LOS B            | 0.9               | 8.7    | 0.72      | 0.67           | 0.72                | 13.9        |
| 8                            | T1   | All MCs   | 414          | 4.3  | 414           | 4.3  | 0.302     | 21.9        | LOS B            | 6.5               | 47.0   | 0.75      | 0.63           | 0.75                | 23.7        |
| 9                            | R2   | All MCs   | 15           | 21.4 | 15            | 21.4 | *0.075    | 33.2        | LOS C            | 0.5               | 4.3    | 0.86      | 0.68           | 0.86                | 11.9        |
| Approach                     |      |           | 458          | 7.4  | 458           | 7.4  | 0.302     | 22.5        | LOS B            | 6.5               | 47.0   | 0.76      | 0.63           | 0.76                | 22.8        |
| West: Erskine St (W)         |      |           |              |      |               |      |           |             |                  |                   |        |           |                |                     |             |
| 10                           | L2   | All MCs   | 96           | 3.3  | 96            | 3.3  | 0.355     | 14.0        | LOS A            | 8.9               | 63.4   | 0.60      | 0.57           | 0.60                | 12.4        |
| 11                           | T1   | All MCs   | 264          | 2.4  | 264           | 2.4  | 0.355     | 13.0        | LOS A            | 8.9               | 63.4   | 0.60      | 0.57           | 0.60                | 12.4        |
| 12                           | R2   | All MCs   | 233          | 3.2  | 233           | 3.2  | *0.533    | 24.2        | LOS B            | 7.7               | 55.5   | 0.79      | 0.78           | 0.79                | 18.9        |
| Approach                     |      |           | 593          | 2.8  | 593           | 2.8  | 0.533     | 17.6        | LOS B            | 8.9               | 63.4   | 0.68      | 0.66           | 0.68                | 16.4        |
| All Vehicles                 |      |           | 2079         | 3.1  | 2079          | 3.1  | 0.533     | 19.6        | LOS B            | 9.3               | 65.1   | 0.66      | 0.64           | 0.66                | 19.9        |

Site Level of Service (LOS) Method: Delay (RTA NSW). Site LOS Method is specified in the Network Data dialog (Override Site Data tab).

Vehicle movement LOS values are based on average delay per movement.

Intersection and Approach LOS values are based on average delay for all vehicle movements.

Delay Model: SIDRA Standard (Control Delay: Geometric Delay is included).

Queue Model: SIDRA queue estimation methods are used for Back of Queue and Queue at Start of Green.

Gap-Acceptance Capacity Formula: SIDRA Standard (Akçelik M3D).

HV (%) values are calculated for All Movement Classes of All Heavy Vehicle Model Designation.

Arrival Flows used in performance calculations are adjusted to include any Initial Queued Demand and Upstream Capacity Constraint effects.

\* Critical Movement (Signal Timing)

| Pedestrian Movement Performance |          |           |             |                  |                       |        |           |                |             |              |             |
|---------------------------------|----------|-----------|-------------|------------------|-----------------------|--------|-----------|----------------|-------------|--------------|-------------|
| Mov ID                          | Crossing | Dem. Flow | Aver. Delay | Level of Service | AVERAGE BACK OF QUEUE |        | Prop. Que | Eff. Stop Rate | Travel Time | Travel Dist. | Aver. Speed |
|                                 |          | ped/h     | sec         |                  | [ Ped                 | Dist ] |           |                | sec         | m            | m/sec       |
|                                 |          |           |             |                  | ped                   | m      |           |                |             |              |             |
| South: Sussex St (S)            |          |           |             |                  |                       |        |           |                |             |              |             |
| P1                              | Full     | 278       | 33.3        | LOS D            | 0.6                   | 0.6    | 0.87      | 0.87           | 50.0        | 20.0         | 0.40        |
| East: Erskine St (E)            |          |           |             |                  |                       |        |           |                |             |              |             |
| P2                              | Full     | 195       | 35.0        | LOS D            | 0.4                   | 0.4    | 0.88      | 0.88           | 51.6        | 20.0         | 0.39        |
| North: Sussex St (N)            |          |           |             |                  |                       |        |           |                |             |              |             |
| P3                              | Full     | 311       | 33.4        | LOS D            | 0.7                   | 0.7    | 0.87      | 0.87           | 50.0        | 20.0         | 0.40        |
| West: Erskine St (W)            |          |           |             |                  |                       |        |           |                |             |              |             |
| P4                              | Full     | 243       | 33.3        | LOS D            | 0.5                   | 0.5    | 0.86      | 0.86           | 49.9        | 20.0         | 0.40        |
| All Pedestrians                 |          | 1026      | 33.6        | LOS D            | 0.7                   | 0.7    | 0.87      | 0.87           | 50.3        | 20.0         | 0.40        |

Level of Service (LOS) Method: SIDRA Pedestrian LOS Method (Based on Average Delay)

Pedestrian movement LOS values are based on average delay per pedestrian movement.

Intersection LOS value for Pedestrians is based on average delay for all pedestrian movements.

**SIDRA INTERSECTION 9.1 | Copyright © 2000-2022 Akcelik and Associates Pty Ltd | sidrasolutions.com**

Organisation: AECOM AUSTRALIA PTY LTD | Licence: NETWORK / Enterprise Level 1 | Processed: Monday, 17 July 2023 11:23:46 AM

Project: C:\Users\YeungMAECOMANZ-NAC-Sydney Metro-Sydney Metro C&SW Operational Monitoring - General\400\_Technical\432\_Traffic Analysis\SIDRA Modelling\01 Models (Geometry Only)\Block 1\Rev1\_Review\04 SM C&SW\_BGU (Block 1)\_PS.sip9

# MOVEMENT SUMMARY

Site: BGU13 [BGU13 Kent St / Erskine St (Site Folder: Block 1 - 2023 PM Peak)]

Output produced by SIDRA INTERSECTION Version: 9.1.3.210

Network: BGU-N2 [BGU Network 3 (Network Folder: Block 1 Network - 2023 PM Peak)]

TCS 307

Site Category: (None)

Signals - EQUISAT (Fixed-Time/SCATS) Coordinated Cycle Time = 90 seconds (Network Site User-Given Phase Times)

| Vehicle Movement Performance |      |           |              |     |               |     |           |             |                  |                   |        |           |                |                     |             |
|------------------------------|------|-----------|--------------|-----|---------------|-----|-----------|-------------|------------------|-------------------|--------|-----------|----------------|---------------------|-------------|
| Mov ID                       | Turn | Mov Class | Demand Flows |     | Arrival Flows |     | Deg. Satn | Aver. Delay | Level of Service | 95% Back Of Queue |        | Prop. Que | Eff. Stop Rate | Aver. No. of Cycles | Aver. Speed |
|                              |      |           | [ Total HV ] | %   | [ Total HV ]  | %   |           |             |                  | [ Veh. veh        | Dist ] |           |                |                     |             |
|                              |      |           | veh/h        | %   | veh/h         | %   | v/c       | sec         |                  |                   | m      |           |                |                     | km/h        |
| South: Kent St (S)           |      |           |              |     |               |     |           |             |                  |                   |        |           |                |                     |             |
| 1                            | L2   | All MCs   | 141          | 0.0 | 141           | 0.0 | 0.163     | 18.2        | LOS B            | 3.5               | 24.8   | 0.61      | 0.68           | 0.61                | 20.7        |
| 2                            | T1   | All MCs   | 674          | 5.5 | 674           | 5.5 | *0.339    | 14.9        | LOS B            | 8.0               | 59.3   | 0.63      | 0.54           | 0.63                | 22.1        |
| 3                            | R2   | All MCs   | 1            | 0.0 | 1             | 0.0 | 0.024     | 8.0         | LOS A            | 1.4               | 3.9    | 0.38      | 0.29           | 0.38                | 24.8        |
| Approach                     |      |           | 816          | 4.5 | 816           | 4.5 | 0.339     | 15.4        | LOS B            | 8.0               | 59.3   | 0.63      | 0.56           | 0.63                | 21.9        |
| East: Erskine St (E)         |      |           |              |     |               |     |           |             |                  |                   |        |           |                |                     |             |
| 5                            | T1   | All MCs   | 273          | 4.2 | 273           | 4.2 | 0.349     | 32.2        | LOS C            | 5.5               | 39.6   | 0.89      | 0.72           | 0.89                | 5.7         |
| 6                            | R2   | All MCs   | 8            | 0.0 | 8             | 0.0 | 0.349     | 40.1        | LOS C            | 5.1               | 37.3   | 0.89      | 0.72           | 0.89                | 5.7         |
| Approach                     |      |           | 281          | 4.1 | 281           | 4.1 | 0.349     | 32.5        | LOS C            | 5.5               | 39.6   | 0.89      | 0.72           | 0.89                | 5.7         |
| North: Kent St (N)           |      |           |              |     |               |     |           |             |                  |                   |        |           |                |                     |             |
| 7                            | L2   | All MCs   | 1            | 0.0 | 1             | 0.0 | 0.038     | 8.0         | LOS A            | 2.5               | 6.6    | 0.38      | 0.31           | 0.38                | 21.6        |
| 8                            | T1   | All MCs   | 160          | 0.0 | 160           | 0.0 | 0.038     | 6.0         | LOS A            | 2.5               | 6.6    | 0.38      | 0.31           | 0.38                | 25.7        |
| 9                            | R2   | All MCs   | 153          | 0.7 | 153           | 0.7 | *0.801    | 51.6        | LOS D            | 7.3               | 51.7   | 1.00      | 0.98           | 1.26                | 5.9         |
| Approach                     |      |           | 314          | 0.3 | 314           | 0.3 | 0.801     | 28.2        | LOS B            | 7.3               | 51.7   | 0.68      | 0.63           | 0.81                | 14.2        |
| West: Erskine St (W)         |      |           |              |     |               |     |           |             |                  |                   |        |           |                |                     |             |
| 10                           | L2   | All MCs   | 54           | 3.9 | 54            | 3.9 | 0.364     | 29.2        | LOS C            | 4.7               | 34.8   | 0.76      | 0.66           | 0.76                | 8.7         |
| 11                           | T1   | All MCs   | 240          | 7.0 | 240           | 7.0 | *0.364    | 26.4        | LOS B            | 4.9               | 36.5   | 0.77      | 0.64           | 0.77                | 11.8        |
| Approach                     |      |           | 294          | 6.5 | 294           | 6.5 | 0.364     | 26.9        | LOS B            | 4.9               | 36.5   | 0.77      | 0.65           | 0.77                | 11.2        |
| All Vehicles                 |      |           | 1704         | 4.0 | 1704          | 4.0 | 0.801     | 22.6        | LOS B            | 8.0               | 59.3   | 0.71      | 0.62           | 0.73                | 15.7        |

Site Level of Service (LOS) Method: Delay (RTA NSW). Site LOS Method is specified in the Network Data dialog (Override Site Data tab).

Vehicle movement LOS values are based on average delay per movement.

Intersection and Approach LOS values are based on average delay for all vehicle movements.

Delay Model: SIDRA Standard (Control Delay: Geometric Delay is included).

Queue Model: SIDRA queue estimation methods are used for Back of Queue and Queue at Start of Green.

Gap-Acceptance Capacity Formula: SIDRA Standard (Akçelik M3D).

HV (%) values are calculated for All Movement Classes of All Heavy Vehicle Model Designation.

Arrival Flows used in performance calculations are adjusted to include any Initial Queued Demand and Upstream Capacity Constraint effects.

\* Critical Movement (Signal Timing)



| Pedestrian Movement Performance |          |           |             |                  |                       |        |           |                |             |              |             |
|---------------------------------|----------|-----------|-------------|------------------|-----------------------|--------|-----------|----------------|-------------|--------------|-------------|
| Mov ID                          | Crossing | Dem. Flow | Aver. Delay | Level of Service | AVERAGE BACK OF QUEUE |        | Prop. Que | Eff. Stop Rate | Travel Time | Travel Dist. | Aver. Speed |
|                                 |          | ped/h     | sec         |                  | [ Ped                 | Dist ] |           |                | sec         | m            | m/sec       |
|                                 |          |           |             |                  | ped                   | m      |           |                |             |              |             |
| South: Kent St (S)              |          |           |             |                  |                       |        |           |                |             |              |             |
| P1                              | Full     | 443       | 36.2        | LOS D            | 1.0                   | 1.0    | 0.91      | 0.91           | 52.9        | 20.0         | 0.38        |
| East: Erskine St (E)            |          |           |             |                  |                       |        |           |                |             |              |             |
| P2                              | Full     | 349       | 37.0        | LOS D            | 0.8                   | 0.8    | 0.91      | 0.91           | 53.7        | 20.0         | 0.37        |
| North: Kent St (N)              |          |           |             |                  |                       |        |           |                |             |              |             |
| P3                              | Full     | 500       | 36.3        | LOS D            | 1.2                   | 1.2    | 0.91      | 0.91           | 53.0        | 20.0         | 0.38        |
| West: Erskine St (W)            |          |           |             |                  |                       |        |           |                |             |              |             |
| P4                              | Full     | 333       | 36.1        | LOS D            | 0.8                   | 0.8    | 0.90      | 0.90           | 52.7        | 20.0         | 0.38        |
| All Pedestrians                 |          | 1625      | 36.4        | LOS D            | 1.2                   | 1.2    | 0.91      | 0.91           | 53.0        | 20.0         | 0.38        |

Level of Service (LOS) Method: SIDRA Pedestrian LOS Method (Based on Average Delay)

Pedestrian movement LOS values are based on average delay per pedestrian movement.

Intersection LOS value for Pedestrians is based on average delay for all pedestrian movements.

**SIDRA INTERSECTION 9.1 | Copyright © 2000-2022 Akcelik and Associates Pty Ltd | sidrasolutions.com**

Organisation: AECOM AUSTRALIA PTY LTD | Licence: NETWORK / Enterprise Level 1 | Processed: Monday, 17 July 2023 11:23:46 AM

Project: C:\Users\YeungMA\AECOM\ANZ-NAC-Sydney Metro-Sydney Metro C&SW Operational Monitoring - General\400\_Technical\432\_Traffic Analysis\SIDRA Modelling\01 Models (Geometry Only)\Block 1\Rev1\_Review\04 SM C&SW\_BGU (Block 1)\_PS.sip9

# MOVEMENT SUMMARY

Site: BGU14 [BGU14 Sussex St / King St (Site Folder: Block 1 - 2023 PM Peak)]

Output produced by SIDRA INTERSECTION Version: 9.1.1.200

Network: BGU-N2 [BGU Network 4 (Network Folder: Block 1 Network - 2023 PM Peak)]

TCS 284

Site Category: (None)

Signals - EQUISAT (Fixed-Time/SCATS) Coordinated Cycle Time = 90 seconds (Network Site User-Given Phase Times)

| Vehicle Movement Performance |      |           |              |      |               |      |           |             |                  |                   |          |           |                |                     |             |
|------------------------------|------|-----------|--------------|------|---------------|------|-----------|-------------|------------------|-------------------|----------|-----------|----------------|---------------------|-------------|
| Mov ID                       | Turn | Mov Class | Demand Flows |      | Arrival Flows |      | Deg. Satn | Aver. Delay | Level of Service | 95% Back Of Queue |          | Prop. Que | Eff. Stop Rate | Aver. No. of Cycles | Aver. Speed |
|                              |      |           | [ Total HV ] | %    | [ Total HV ]  | %    |           |             |                  | [ Veh. veh        | Dist ] m |           |                |                     |             |
| East: King St (E)            |      |           |              |      |               |      |           |             |                  |                   |          |           |                |                     |             |
| 4a                           | L1   | All MCs   | 155          | 0.0  | 155           | 0.0  | 0.243     | 44.0        | LOS D            | 6.6               | 17.9     | 1.00      | 0.78           | 1.00                | 18.5        |
| Approach                     |      |           | 155          | 0.0  | 155           | 0.0  | 0.243     | 44.0        | LOS D            | 6.6               | 17.9     | 1.00      | 0.78           | 1.00                | 18.5        |
| North: Sussex St (N)         |      |           |              |      |               |      |           |             |                  |                   |          |           |                |                     |             |
| 7                            | L2   | All MCs   | 154          | 12.3 | 154           | 12.3 | *0.665    | 26.6        | LOS B            | 18.9              | 136.9    | 0.85      | 0.77           | 0.85                | 18.5        |
| 8                            | T1   | All MCs   | 975          | 1.1  | 975           | 1.1  | 0.665     | 20.6        | LOS B            | 20.0              | 141.6    | 0.84      | 0.76           | 0.84                | 26.0        |
| Approach                     |      |           | 1128         | 2.6  | 1128          | 2.6  | 0.665     | 21.4        | LOS B            | 20.0              | 141.6    | 0.84      | 0.76           | 0.84                | 25.3        |
| SouthWest: King St (SW)      |      |           |              |      |               |      |           |             |                  |                   |          |           |                |                     |             |
| 30a                          | L1   | All MCs   | 448          | 0.2  | 448           | 0.2  | 0.543     | 14.5        | LOS A            | 8.9               | 62.4     | 0.79      | 0.79           | 0.79                | 36.4        |
| 32a                          | R1   | All MCs   | 935          | 3.2  | 935           | 3.2  | *0.575    | 26.4        | LOS B            | 14.8              | 106.7    | 0.83      | 0.79           | 0.83                | 28.5        |
| 32b                          | R3   | All MCs   | 179          | 10.6 | 179           | 10.6 | 0.296     | 24.5        | LOS B            | 5.3               | 40.5     | 0.71      | 0.77           | 0.71                | 31.9        |
| Approach                     |      |           | 1562         | 3.2  | 1562          | 3.2  | 0.575     | 22.8        | LOS B            | 14.8              | 106.7    | 0.81      | 0.79           | 0.81                | 31.3        |
| All Vehicles                 |      |           | 2845         | 2.8  | 2845          | 2.8  | 0.665     | 23.4        | LOS B            | 20.0              | 141.6    | 0.83      | 0.78           | 0.83                | 28.0        |

Site Level of Service (LOS) Method: Delay (RTA NSW). Site LOS Method is specified in the Network Data dialog (Override Site Data tab).

Vehicle movement LOS values are based on average delay per movement.

Intersection and Approach LOS values are based on average delay for all vehicle movements.

Delay Model: SIDRA Standard (Control Delay: Geometric Delay is included).

Queue Model: SIDRA queue estimation methods are used for Back of Queue and Queue at Start of Green.

Gap-Acceptance Capacity Formula: SIDRA Standard (Akçelik M3D).

HV (%) values are calculated for All Movement Classes of All Heavy Vehicle Model Designation.

Arrival Flows used in performance calculations are adjusted to include any Initial Queued Demand and Upstream Capacity Constraint effects.

\* Critical Movement (Signal Timing)

| Pedestrian Movement Performance |                 |                    |                    |                  |                       |             |           |                |                    |                   |                      |
|---------------------------------|-----------------|--------------------|--------------------|------------------|-----------------------|-------------|-----------|----------------|--------------------|-------------------|----------------------|
| Mov ID                          | Crossing        | Dem. Flow<br>ped/h | Aver. Delay<br>sec | Level of Service | AVERAGE BACK OF QUEUE |             | Prop. Que | Eff. Stop Rate | Travel Time<br>sec | Travel Dist.<br>m | Aver. Speed<br>m/sec |
|                                 |                 |                    |                    |                  | [ Ped<br>ped          | Dist ]<br>m |           |                |                    |                   |                      |
| South: Sussex St (S)            |                 |                    |                    |                  |                       |             |           |                |                    |                   |                      |
| P1                              | Full            | 184                | 40.4               | LOS E            | 0.4                   | 0.4         | 0.95      | 0.95           | 57.1               | 20.0              | 0.35                 |
| East: King St (E)               |                 |                    |                    |                  |                       |             |           |                |                    |                   |                      |
| P2                              | Full            | 168                | 36.7               | LOS D            | 0.4                   | 0.4         | 0.91      | 0.91           | 53.4               | 20.0              | 0.37                 |
| North: Sussex St (N)            |                 |                    |                    |                  |                       |             |           |                |                    |                   |                      |
| P3                              | Full            | 554                | 36.4               | LOS D            | 1.3                   | 1.3         | 0.91      | 0.91           | 53.1               | 20.0              | 0.38                 |
| SouthWest: King St (SW)         |                 |                    |                    |                  |                       |             |           |                |                    |                   |                      |
| P8                              | Full            | 398                | 38.0               | LOS D            | 0.9                   | 0.9         | 0.93      | 0.93           | 204.7              | 200.0             | 0.98                 |
| P8B                             | Slip/<br>Bypass | 331                | 40.7               | LOS E            | 0.8                   | 0.8         | 0.96      | 0.96           | 207.4              | 200.0             | 0.96                 |
| All Pedestrians                 |                 | 1635               | 38.1               | LOS D            | 1.3                   | 1.3         | 0.93      | 0.93           | 121.6              | 100.2             | 0.82                 |

Level of Service (LOS) Method: SIDRA Pedestrian LOS Method (Based on Average Delay)  
 Pedestrian movement LOS values are based on average delay per pedestrian movement.  
 Intersection LOS value for Pedestrians is based on average delay for all pedestrian movements.

# MOVEMENT SUMMARY

Site: BGU15 [BGU15 Kent St / King St (Site Folder: Block 1 - 2023 PM Peak)]

Output produced by SIDRA INTERSECTION Version: 9.1.1.200

Network: BGU-N2 [BGU Network 4 (Network Folder: Block 1 Network - 2023 PM Peak)]

TCS 283

Site Category: NA

Signals - EQUISAT (Fixed-Time/SCATS) Coordinated Cycle Time = 90 seconds (Network Site User-Given Phase Times)

| Vehicle Movement Performance |      |           |              |     |               |     |           |             |                  |                   |        |           |                |                     |             |
|------------------------------|------|-----------|--------------|-----|---------------|-----|-----------|-------------|------------------|-------------------|--------|-----------|----------------|---------------------|-------------|
| Mov ID                       | Turn | Mov Class | Demand Flows |     | Arrival Flows |     | Deg. Satn | Aver. Delay | Level of Service | 95% Back Of Queue |        | Prop. Que | Eff. Stop Rate | Aver. No. of Cycles | Aver. Speed |
|                              |      |           | [ Total HV ] | %   | [ Total HV ]  | %   |           |             |                  | [ Veh. veh        | Dist ] |           |                |                     |             |
|                              |      |           | veh/h        | %   | veh/h         | %   | v/c       | sec         |                  | m                 |        |           |                |                     | km/h        |
| South: Kent St (S)           |      |           |              |     |               |     |           |             |                  |                   |        |           |                |                     |             |
| 1                            | L2   | All MCs   | 15           | 0.0 | 15            | 0.0 | 0.112     | 41.6        | LOS C            | 3.1               | 8.4    | 0.94      | 0.69           | 0.94                | 14.1        |
| 2                            | T1   | All MCs   | 568          | 6.7 | 568           | 6.7 | *0.520    | 31.6        | LOS C            | 9.6               | 71.3   | 0.91      | 0.75           | 0.91                | 22.1        |
| 3                            | R2   | All MCs   | 187          | 1.1 | 187           | 1.1 | 0.404     | 36.2        | LOS C            | 6.5               | 46.2   | 0.90      | 0.77           | 0.90                | 15.6        |
| Approach                     |      |           | 771          | 5.2 | 771           | 5.2 | 0.520     | 32.9        | LOS C            | 9.6               | 71.3   | 0.90      | 0.76           | 0.90                | 20.5        |
| East: King St (E)            |      |           |              |     |               |     |           |             |                  |                   |        |           |                |                     |             |
| 5                            | T1   | All MCs   | 56           | 0.0 | 56            | 0.0 | 0.112     | 40.0        | LOS C            | 2.4               | 6.4    | 0.95      | 0.69           | 0.95                | 4.9         |
| 6                            | R2   | All MCs   | 3            | 0.0 | 3             | 0.0 | 0.112     | 49.2        | LOS D            | 2.4               | 6.4    | 0.95      | 0.69           | 0.95                | 14.6        |
| Approach                     |      |           | 59           | 0.0 | 59            | 0.0 | 0.112     | 40.5        | LOS C            | 2.4               | 6.4    | 0.95      | 0.69           | 0.95                | 5.6         |
| North: Kent St (N)           |      |           |              |     |               |     |           |             |                  |                   |        |           |                |                     |             |
| 7                            | L2   | All MCs   | 14           | 0.0 | 14            | 0.0 | 0.126     | 41.7        | LOS C            | 3.5               | 9.5    | 0.94      | 0.70           | 0.94                | 11.3        |
| 8                            | T1   | All MCs   | 77           | 0.0 | 77            | 0.0 | 0.126     | 38.3        | LOS C            | 3.5               | 9.5    | 0.94      | 0.70           | 0.94                | 20.1        |
| 9                            | R2   | All MCs   | 84           | 0.0 | 84            | 0.0 | *0.291    | 44.6        | LOS D            | 3.5               | 9.5    | 0.97      | 0.75           | 0.97                | 12.5        |
| Approach                     |      |           | 175          | 0.0 | 175           | 0.0 | 0.291     | 41.6        | LOS C            | 3.5               | 9.5    | 0.95      | 0.72           | 0.95                | 16.0        |
| West: King St (W)            |      |           |              |     |               |     |           |             |                  |                   |        |           |                |                     |             |
| 10                           | L2   | All MCs   | 184          | 0.0 | 184           | 0.0 | *0.502    | 32.6        | LOS C            | 7.5               | 53.1   | 0.78      | 0.70           | 0.78                | 19.0        |
| 11                           | T1   | All MCs   | 900          | 5.0 | 900           | 5.0 | 0.502     | 8.5         | LOS A            | 7.5               | 53.1   | 0.42      | 0.36           | 0.42                | 22.2        |
| Approach                     |      |           | 1084         | 4.2 | 1084          | 4.2 | 0.502     | 12.6        | LOS A            | 7.5               | 53.1   | 0.48      | 0.42           | 0.48                | 21.1        |
| All Vehicles                 |      |           | 2088         | 4.1 | 2088          | 4.1 | 0.520     | 23.3        | LOS B            | 9.6               | 71.3   | 0.69      | 0.58           | 0.69                | 19.7        |

Site Level of Service (LOS) Method: Delay (RTA NSW). Site LOS Method is specified in the Network Data dialog (Override Site Data tab).

Vehicle movement LOS values are based on average delay per movement.

Intersection and Approach LOS values are based on average delay for all vehicle movements.

Delay Model: SIDRA Standard (Control Delay: Geometric Delay is included).

Queue Model: SIDRA queue estimation methods are used for Back of Queue and Queue at Start of Green.

Gap-Acceptance Capacity Formula: SIDRA Standard (Akçelik M3D).

HV (%) values are calculated for All Movement Classes of All Heavy Vehicle Model Designation.

Arrival Flows used in performance calculations are adjusted to include any Initial Queued Demand and Upstream Capacity Constraint effects.

\* Critical Movement (Signal Timing)

| Pedestrian Movement Performance |          |           |             |                  |                       |        |           |                |             |              |             |
|---------------------------------|----------|-----------|-------------|------------------|-----------------------|--------|-----------|----------------|-------------|--------------|-------------|
| Mov ID                          | Crossing | Dem. Flow | Aver. Delay | Level of Service | AVERAGE BACK OF QUEUE |        | Prop. Que | Eff. Stop Rate | Travel Time | Travel Dist. | Aver. Speed |
|                                 |          | ped/h     | sec         |                  | [ Ped                 | Dist ] |           |                | sec         | m            | m/sec       |
|                                 |          |           |             |                  | ped                   | m      |           |                |             |              |             |
| South: Kent St (S)              |          |           |             |                  |                       |        |           |                |             |              |             |
| P1                              | Full     | 343       | 37.0        | LOS D            | 0.8                   | 0.8    | 0.91      | 0.91           | 53.6        | 20.0         | 0.37        |
| East: King St (E)               |          |           |             |                  |                       |        |           |                |             |              |             |
| P2                              | Full     | 252       | 37.8        | LOS D            | 0.6                   | 0.6    | 0.92      | 0.92           | 54.4        | 20.0         | 0.37        |
| North: Kent St (N)              |          |           |             |                  |                       |        |           |                |             |              |             |
| P3                              | Full     | 428       | 38.0        | LOS D            | 1.0                   | 1.0    | 0.93      | 0.93           | 54.7        | 20.0         | 0.37        |
| West: King St (W)               |          |           |             |                  |                       |        |           |                |             |              |             |
| P4                              | Full     | 460       | 38.1        | LOS D            | 1.1                   | 1.1    | 0.93      | 0.93           | 54.8        | 20.0         | 0.37        |
| All Pedestrians                 |          | 1483      | 37.8        | LOS D            | 1.1                   | 1.1    | 0.92      | 0.92           | 54.4        | 20.0         | 0.37        |

Level of Service (LOS) Method: SIDRA Pedestrian LOS Method (Based on Average Delay)

Pedestrian movement LOS values are based on average delay per pedestrian movement.

Intersection LOS value for Pedestrians is based on average delay for all pedestrian movements.

**SIDRA INTERSECTION 9.1 | Copyright © 2000-2022 Akcelik and Associates Pty Ltd | sidrasolutions.com**

Organisation: AECOM AUSTRALIA PTY LTD | Licence: NETWORK / Enterprise Level 1 | Processed: Friday, 14 July 2023 3:11:29 PM

Project: C:\Users\YeungMA\AECOM\ANZ-NAC-Sydney Metro-Sydney Metro C&SW Operational Monitoring - General\400\_Technical\432\_Traffic Analysis\SIDRA Modelling\01 Models (Geometry Only)\Block 1\Rev1\_Review\04 SM C&SW\_BGU (Block 1)\_PS.sip9

# MOVEMENT SUMMARY

Site: BGU18 [BGU18 Shelley St / Erskine St (Site Folder: Block 1 - 2023 PM Peak)]

Output produced by SIDRA INTERSECTION Version: 9.1.3.210

Network: BGU-N2 [BGU Network 3 (Network Folder: Block 1 Network - 2023 PM Peak)]

TCS 305

Site Category: (None)

Signals - EQUISAT (Fixed-Time/SCATS) Isolated Cycle Time = 45 seconds (Site User-Given Phase Times)

| Vehicle Movement Performance |      |           |                       |      |                       |      |           |             |                  |                   |               |           |                |                     |                  |
|------------------------------|------|-----------|-----------------------|------|-----------------------|------|-----------|-------------|------------------|-------------------|---------------|-----------|----------------|---------------------|------------------|
| Mov ID                       | Turn | Mov Class | Demand Flows          |      | Arrival Flows         |      | Deg. Satn | Aver. Delay | Level of Service | 95% Back Of Queue |               | Prop. Que | Eff. Stop Rate | Aver. No. of Cycles | Aver. Speed km/h |
|                              |      |           | [ Total HV ]<br>veh/h | %    | [ Total HV ]<br>veh/h | %    |           |             |                  | [ Veh. veh        | [ Dist ]<br>m |           |                |                     |                  |
| South: Shelley St (S)        |      |           |                       |      |                       |      |           |             |                  |                   |               |           |                |                     |                  |
| 1                            | L2   | All MCs   | 20                    | 5.3  | 20                    | 5.3  | 0.154     | 16.9        | LOS B            | 1.6               | 11.3          | 0.71      | 0.59           | 0.71                | 17.4             |
| 2                            | T1   | All MCs   | 82                    | 2.6  | 82                    | 2.6  | 0.154     | 10.3        | LOS A            | 1.6               | 11.3          | 0.71      | 0.59           | 0.71                | 23.9             |
| 3                            | R2   | All MCs   | 203                   | 2.6  | 203                   | 2.6  | *0.687    | 22.6        | LOS B            | 4.7               | 33.3          | 0.95      | 0.92           | 1.13                | 12.4             |
| Approach                     |      |           | 305                   | 2.8  | 305                   | 2.8  | 0.687     | 18.9        | LOS B            | 4.7               | 33.3          | 0.87      | 0.81           | 0.99                | 15.6             |
| East: Erskine St (E)         |      |           |                       |      |                       |      |           |             |                  |                   |               |           |                |                     |                  |
| 4                            | L2   | All MCs   | 49                    | 21.3 | 49                    | 21.3 | 0.147     | 19.4        | LOS B            | 0.9               | 7.6           | 0.84      | 0.70           | 0.84                | 16.5             |
| 5                            | T1   | All MCs   | 104                   | 1.0  | 104                   | 1.0  | *0.285    | 12.4        | LOS A            | 2.6               | 18.0          | 0.80      | 0.67           | 0.80                | 16.6             |
| 6                            | R2   | All MCs   | 43                    | 0.0  | 43                    | 0.0  | 0.285     | 18.5        | LOS B            | 2.6               | 18.0          | 0.80      | 0.67           | 0.80                | 17.8             |
| Approach                     |      |           | 197                   | 5.9  | 197                   | 5.9  | 0.285     | 15.5        | LOS B            | 2.6               | 18.0          | 0.81      | 0.68           | 0.81                | 16.8             |
| North: Shelley St (N)        |      |           |                       |      |                       |      |           |             |                  |                   |               |           |                |                     |                  |
| 7                            | L2   | All MCs   | 196                   | 0.0  | 196                   | 0.0  | 0.470     | 16.3        | LOS B            | 3.5               | 24.8          | 0.82      | 0.77           | 0.82                | 13.4             |
| 8                            | T1   | All MCs   | 3                     | 33.3 | 3                     | 33.3 | 0.020     | 10.6        | LOS A            | 0.1               | 1.1           | 0.69      | 0.56           | 0.69                | 22.5             |
| 9                            | R2   | All MCs   | 5                     | 20.0 | 5                     | 20.0 | 0.020     | 14.9        | LOS B            | 0.1               | 1.1           | 0.69      | 0.56           | 0.69                | 14.0             |
| Approach                     |      |           | 204                   | 1.0  | 204                   | 1.0  | 0.470     | 16.1        | LOS B            | 3.5               | 24.8          | 0.81      | 0.76           | 0.81                | 13.6             |
| West: Erskine St (W)         |      |           |                       |      |                       |      |           |             |                  |                   |               |           |                |                     |                  |
| 10                           | L2   | All MCs   | 15                    | 0.0  | 15                    | 0.0  | 0.240     | 19.5        | LOS B            | 1.6               | 12.0          | 0.76      | 0.62           | 0.76                | 19.1             |
| 11                           | T1   | All MCs   | 194                   | 6.0  | 194                   | 6.0  | 0.240     | 11.5        | LOS A            | 1.9               | 13.8          | 0.75      | 0.61           | 0.75                | 13.2             |
| 12                           | R2   | All MCs   | 4                     | 25.0 | 4                     | 25.0 | 0.240     | 19.1        | LOS B            | 1.9               | 13.8          | 0.74      | 0.60           | 0.74                | 21.6             |
| Approach                     |      |           | 213                   | 5.9  | 213                   | 5.9  | 0.240     | 12.2        | LOS A            | 1.9               | 13.8          | 0.75      | 0.61           | 0.75                | 14.0             |
| All Vehicles                 |      |           | 919                   | 3.8  | 919                   | 3.8  | 0.687     | 16.0        | LOS B            | 4.7               | 33.3          | 0.82      | 0.72           | 0.86                | 15.2             |

Site Level of Service (LOS) Method: Delay (RTA NSW). Site LOS Method is specified in the Network Data dialog (Override Site Data tab).

Vehicle movement LOS values are based on average delay per movement.

Intersection and Approach LOS values are based on average delay for all vehicle movements.

Delay Model: SIDRA Standard (Control Delay: Geometric Delay is included).

Queue Model: SIDRA queue estimation methods are used for Back of Queue and Queue at Start of Green.

Gap-Acceptance Capacity Formula: SIDRA Standard (Akçelik M3D).

HV (%) values are calculated for All Movement Classes of All Heavy Vehicle Model Designation.

Arrival Flows used in performance calculations are adjusted to include any Initial Queued Demand and Upstream Capacity Constraint effects.

\* Critical Movement (Signal Timing)

| Pedestrian Movement Performance |          |           |             |                  |                       |        |           |                |             |              |             |
|---------------------------------|----------|-----------|-------------|------------------|-----------------------|--------|-----------|----------------|-------------|--------------|-------------|
| Mov ID                          | Crossing | Dem. Flow | Aver. Delay | Level of Service | AVERAGE BACK OF QUEUE |        | Prop. Que | Eff. Stop Rate | Travel Time | Travel Dist. | Aver. Speed |
|                                 |          | ped/h     | sec         |                  | [ Ped                 | Dist ] |           |                | sec         | m            | m/sec       |
|                                 |          |           |             |                  | ped                   | m      |           |                |             |              |             |
| South: Shelley St (S)           |          |           |             |                  |                       |        |           |                |             |              |             |
| P1                              | Full     | 272       | 11.5        | LOS B            | 0.2                   | 0.2    | 0.72      | 0.72           | 178.2       | 200.0        | 1.12        |
| East: Erskine St (E)            |          |           |             |                  |                       |        |           |                |             |              |             |
| P2                              | Full     | 56        | 11.4        | LOS B            | 0.1                   | 0.1    | 0.71      | 0.71           | 178.1       | 200.0        | 1.12        |
| North: Shelley St (N)           |          |           |             |                  |                       |        |           |                |             |              |             |
| P3                              | Full     | 237       | 11.5        | LOS B            | 0.2                   | 0.2    | 0.72      | 0.72           | 178.2       | 200.0        | 1.12        |
| West: Erskine St (W)            |          |           |             |                  |                       |        |           |                |             |              |             |
| P4                              | Full     | 179       | 11.5        | LOS B            | 0.2                   | 0.2    | 0.72      | 0.72           | 178.1       | 200.0        | 1.12        |
| All Pedestrians                 |          | 743       | 11.5        | LOS B            | 0.2                   | 0.2    | 0.72      | 0.72           | 178.2       | 200.0        | 1.12        |

Level of Service (LOS) Method: SIDRA Pedestrian LOS Method (Based on Average Delay)

Pedestrian movement LOS values are based on average delay per pedestrian movement.

Intersection LOS value for Pedestrians is based on average delay for all pedestrian movements.

**SIDRA INTERSECTION 9.1 | Copyright © 2000-2022 Akcelik and Associates Pty Ltd | sidrasolutions.com**

Organisation: AECOM AUSTRALIA PTY LTD | Licence: NETWORK / Enterprise Level 1 | Processed: Monday, 17 July 2023 11:23:46 AM

Project: C:\Users\YeungMA\AECOM\ANZ-NAC-Sydney Metro-Sydney Metro C&SW Operational Monitoring - General\400\_Technical\432\_Traffic Analysis\SIDRA Modelling\01 Models (Geometry Only)\Block 1\Rev1\_Review\04 SM C&SW\_BGU (Block 1)\_PS.sip9

# MOVEMENT SUMMARY

Site: BUG01 [BGU01 Hickson Rd / Towns PI (Site Folder: Block 1 - 2023 Weekend Peak)]

Output produced by SIDRA INTERSECTION Version: 9.1.1.200

Network: BGU-N1 [BGU Network 1 (Network Folder: Block 1 Network - 2023 Weekend Peak)]

Site Category: (None)  
Give-Way (Two-Way)

| Vehicle Movement Performance |      |           |              |      |               |      |           |             |                  |                   |        |           |                |                     |             |
|------------------------------|------|-----------|--------------|------|---------------|------|-----------|-------------|------------------|-------------------|--------|-----------|----------------|---------------------|-------------|
| Mov ID                       | Turn | Mov Class | Demand Flows |      | Arrival Flows |      | Deg. Satn | Aver. Delay | Level of Service | 95% Back Of Queue |        | Prop. Que | Eff. Stop Rate | Aver. No. of Cycles | Aver. Speed |
|                              |      |           | [ Total HV ] | %    | [ Total HV ]  | %    |           |             |                  | [ Veh. veh        | Dist ] |           |                |                     |             |
| East: Hickson Rd (E)         |      |           |              |      |               |      |           |             |                  |                   |        |           |                |                     |             |
| 4a                           | L1   | All MCs   | 134          | 5.5  | 134           | 5.5  | 0.153     | 3.7         | LOS A            | 0.7               | 5.1    | 0.19      | 0.46           | 0.19                | 37.7        |
| 6a                           | R1   | All MCs   | 72           | 0.0  | 72            | 0.0  | 0.153     | 4.2         | LOS A            | 0.7               | 5.1    | 0.19      | 0.46           | 0.19                | 35.7        |
| Approach                     |      |           | 205          | 3.6  | 205           | 3.6  | 0.153     | 3.9         | NA               | 0.7               | 5.1    | 0.19      | 0.46           | 0.19                | 37.4        |
| NorthWest: Towns PI (NW)     |      |           |              |      |               |      |           |             |                  |                   |        |           |                |                     |             |
| 27a                          | L1   | All MCs   | 134          | 5.5  | 134           | 5.5  | 0.159     | 3.6         | LOS A            | 0.6               | 4.6    | 0.39      | 0.54           | 0.39                | 35.7        |
| 29                           | R2   | All MCs   | 41           | 0.0  | 41            | 0.0  | 0.159     | 6.1         | LOS A            | 0.6               | 4.6    | 0.39      | 0.54           | 0.39                | 36.8        |
| Approach                     |      |           | 175          | 4.2  | 175           | 4.2  | 0.159     | 4.2         | LOS A            | 0.6               | 4.6    | 0.39      | 0.54           | 0.39                | 36.1        |
| SouthWest: Hickson Rd (SW)   |      |           |              |      |               |      |           |             |                  |                   |        |           |                |                     |             |
| 30                           | L2   | All MCs   | 49           | 10.6 | 49            | 10.6 | 0.159     | 3.8         | LOS A            | 0.8               | 5.7    | 0.15      | 0.38           | 0.15                | 37.8        |
| 32a                          | R1   | All MCs   | 204          | 2.6  | 204           | 2.6  | 0.159     | 2.6         | LOS A            | 0.8               | 5.7    | 0.15      | 0.38           | 0.15                | 38.3        |
| Approach                     |      |           | 254          | 4.1  | 254           | 4.1  | 0.159     | 2.8         | NA               | 0.8               | 5.7    | 0.15      | 0.38           | 0.15                | 38.2        |
| All Vehicles                 |      |           | 634          | 4.0  | 634           | 4.0  | 0.159     | 3.5         | NA               | 0.8               | 5.7    | 0.23      | 0.45           | 0.23                | 37.5        |

Site Level of Service (LOS) Method: Delay (RTA NSW). Site LOS Method is specified in the Network Data dialog (Override Site Data tab).

Vehicle movement LOS values are based on average delay per movement.

Minor Road Approach LOS values are based on average delay for all vehicle movements.

NA (TWSC): Level of Service is not defined for major road approaches or the intersection as a whole for Two-Way Sign Control (HCM LOS rule).

Two-Way Sign Control Capacity Model: SIDRA Standard.

Delay Model: SIDRA Standard (Control Delay: Geometric Delay is included).

Queue Model: SIDRA queue estimation methods are used for Back of Queue and Queue at Start of Gap.

Gap-Acceptance Capacity Formula: SIDRA Standard (Akçelik M3D).

HV (%) values are calculated for All Movement Classes of All Heavy Vehicle Model Designation.

Arrival Flows used in performance calculations are adjusted to include any Initial Queued Demand and Upstream Capacity Constraint effects.



---

**SIDRA INTERSECTION 9.1 | Copyright © 2000-2022 Akcelik and Associates Pty Ltd | sidrasolutions.com**

Organisation: AECOM AUSTRALIA PTY LTD | Licence: NETWORK / Enterprise Level 1 | Processed: Friday, 14 July 2023 3:14:13 PM

Project: C:\Users\Yeung\AECOM\ANZ-NAC-Sydney Metro-Sydney Metro C&SW Operational Monitoring - General\400\_Technical\432\_Traffic Analysis\SIDRA Modelling\01 Models (Geometry Only)\Block 1\Rev1\\_Review\04 SM C&SW\_BGU (Block 1)\_PS.sip9

# MOVEMENT SUMMARY

Site: BGU02 [BGU02 Dalgety Rd / Towns PI (Site Folder: Block 1 - 2023 Weekend Peak)]

Output produced by SIDRA INTERSECTION Version: 9.1.1.200

Network: BGU-N1 [BGU Network 1 (Network Folder: Block 1 Network - 2023 Weekend Peak)]

Site Category: (None)  
Roundabout

| Vehicle Movement Performance |      |           |              |     |               |     |           |             |                  |                   |          |           |                |                     |             |
|------------------------------|------|-----------|--------------|-----|---------------|-----|-----------|-------------|------------------|-------------------|----------|-----------|----------------|---------------------|-------------|
| Mov ID                       | Turn | Mov Class | Demand Flows |     | Arrival Flows |     | Deg. Satn | Aver. Delay | Level of Service | 95% Back Of Queue |          | Prop. Que | Eff. Stop Rate | Aver. No. of Cycles | Aver. Speed |
|                              |      |           | [ Total HV ] | %   | [ Total HV ]  | %   |           |             |                  | [ Veh. veh        | Dist ] m |           |                |                     |             |
| South: Dalgety Rd (S)        |      |           |              |     |               |     |           |             |                  |                   |          |           |                |                     |             |
| 30                           | L2   | All MCs   | 5            | 0.0 | 5             | 0.0 | 0.105     | 6.3         | LOS A            | 0.6               | 4.3      | 0.19      | 0.55           | 0.19                | 24.4        |
| 3b                           | R3   | All MCs   | 133          | 4.0 | 133           | 4.0 | 0.105     | 6.5         | LOS A            | 0.6               | 4.3      | 0.19      | 0.55           | 0.19                | 31.9        |
| 32u                          | U    | All MCs   | 1            | 0.0 | 1             | 0.0 | 0.105     | 7.2         | LOS A            | 0.6               | 4.3      | 0.19      | 0.55           | 0.19                | 34.5        |
| Approach                     |      |           | 139          | 3.8 | 139           | 3.8 | 0.105     | 6.5         | LOS A            | 0.6               | 4.3      | 0.19      | 0.55           | 0.19                | 31.5        |
| SouthEast: Towns PI (SE)     |      |           |              |     |               |     |           |             |                  |                   |          |           |                |                     |             |
| 21b                          | L3   | All MCs   | 54           | 9.8 | 54            | 9.8 | 0.067     | 2.6         | LOS A            | 0.4               | 2.9      | 0.05      | 0.62           | 0.05                | 33.9        |
| 21a                          | L1   | All MCs   | 36           | 2.9 | 36            | 2.9 | 0.067     | 8.1         | LOS A            | 0.4               | 2.9      | 0.05      | 0.62           | 0.05                | 18.1        |
| 23u                          | U    | All MCs   | 13           | 0.0 | 13            | 0.0 | 0.067     | 6.9         | LOS A            | 0.4               | 2.9      | 0.05      | 0.62           | 0.05                | 27.2        |
| Approach                     |      |           | 102          | 6.2 | 102           | 6.2 | 0.067     | 5.1         | LOS A            | 0.4               | 2.9      | 0.05      | 0.62           | 0.05                | 28.1        |
| West: Parking Access (W)     |      |           |              |     |               |     |           |             |                  |                   |          |           |                |                     |             |
| 12a                          | R1   | All MCs   | 4            | 0.0 | 4             | 0.0 | 0.007     | 0.8         | LOS A            | 0.0               | 0.3      | 0.33      | 0.14           | 0.33                | 9.7         |
| 29                           | R2   | All MCs   | 3            | 0.0 | 3             | 0.0 | 0.007     | 0.8         | LOS A            | 0.0               | 0.3      | 0.33      | 0.14           | 0.33                | 21.7        |
| 29u                          | U    | All MCs   | 1            | 0.0 | 1             | 0.0 | 0.007     | 0.8         | LOS A            | 0.0               | 0.3      | 0.33      | 0.14           | 0.33                | 9.8         |
| Approach                     |      |           | 8            | 0.0 | 8             | 0.0 | 0.007     | 0.8         | LOS A            | 0.0               | 0.3      | 0.33      | 0.14           | 0.33                | 15.7        |
| All Vehicles                 |      |           | 249          | 4.6 | 249           | 4.6 | 0.105     | 5.7         | LOS A            | 0.6               | 4.3      | 0.14      | 0.57           | 0.14                | 29.5        |

Site Level of Service (LOS) Method: Delay (RTA NSW). Site LOS Method is specified in the Network Data dialog (Override Site Data tab).

Vehicle movement LOS values are based on average delay per movement.

Intersection and Approach LOS values are based on average delay for all vehicle movements.

Roundabout Capacity Model: SIDRA Standard.

Delay Model: SIDRA Standard (Control Delay: Geometric Delay is included).

Queue Model: SIDRA queue estimation methods are used for Back of Queue and Queue at Start of Gap.

Gap-Acceptance Capacity Formula: SIDRA Standard (Akçelik M3D).

HV (%) values are calculated for All Movement Classes of All Heavy Vehicle Model Designation.

Arrival Flows used in performance calculations are adjusted to include any Initial Queued Demand and Upstream Capacity Constraint effects.

---

**SIDRA INTERSECTION 9.1 | Copyright © 2000-2022 Akcelik and Associates Pty Ltd | sidrasolutions.com**

Organisation: AECOM AUSTRALIA PTY LTD | Licence: NETWORK / Enterprise Level 1 | Processed: Friday, 14 July 2023 3:14:13 PM

Project: C:\Users\Yeung\AECOM\ANZ-NAC-Sydney Metro-Sydney Metro C&SW Operational Monitoring - General\400\_Technical\432\_Traffic Analysis\SIDRA Modelling\01 Models (Geometry Only)\Block 1\Rev1\\_Review\04 SM C&SW\_BGU (Block 1)\_PS.sip9

# MOVEMENT SUMMARY

Site: **BGU03 [BGU03 Kent St / Argyle St (Site Folder: Block 1 - 2023 Weekend Peak)]**

Output produced by **SIDRA INTERSECTION Version: 9.1.1.200**

Site Category: (None)  
Give-Way (Two-Way)

| Vehicle Movement Performance |      |           |                       |      |                       |      |           |             |                  |                   |               |           |                |                     |             |
|------------------------------|------|-----------|-----------------------|------|-----------------------|------|-----------|-------------|------------------|-------------------|---------------|-----------|----------------|---------------------|-------------|
| Mov ID                       | Turn | Mov Class | Demand Flows          |      | Arrival Flows         |      | Deg. Satn | Aver. Delay | Level of Service | 95% Back Of Queue |               | Prop. Que | Eff. Stop Rate | Aver. No. of Cycles | Aver. Speed |
|                              |      |           | [ Total HV ]<br>veh/h | %    | [ Total HV ]<br>veh/h | %    |           |             |                  | [ Veh. ]<br>veh   | [ Dist ]<br>m |           |                |                     |             |
| South: Kent St (S)           |      |           |                       |      |                       |      |           |             |                  |                   |               |           |                |                     |             |
| 1                            | L2   | All MCs   | 75                    | 1.4  | 75                    | 1.4  | 0.360     | 3.7         | LOS A            | 1.6               | 11.7          | 0.40      | 0.54           | 0.40                | 36.2        |
| 2                            | T1   | All MCs   | 31                    | 0.0  | 31                    | 0.0  | 0.360     | 3.7         | LOS A            | 1.6               | 11.7          | 0.40      | 0.54           | 0.40                | 35.3        |
| 3                            | R2   | All MCs   | 208                   | 3.5  | 208                   | 3.5  | 0.360     | 6.6         | LOS A            | 1.6               | 11.7          | 0.40      | 0.54           | 0.40                | 35.3        |
| Approach                     |      |           | 314                   | 2.7  | 314                   | 2.7  | 0.360     | 5.6         | LOS A            | 1.6               | 11.7          | 0.40      | 0.54           | 0.40                | 35.5        |
| East: Argyle St (E)          |      |           |                       |      |                       |      |           |             |                  |                   |               |           |                |                     |             |
| 4                            | L2   | All MCs   | 136                   | 3.1  | 136                   | 3.1  | 0.172     | 3.7         | LOS A            | 0.8               | 6.1           | 0.19      | 0.34           | 0.19                | 36.9        |
| 5                            | T1   | All MCs   | 61                    | 15.5 | 61                    | 15.5 | 0.172     | 0.5         | LOS A            | 0.8               | 6.1           | 0.19      | 0.34           | 0.19                | 36.7        |
| 6                            | R2   | All MCs   | 18                    | 0.0  | 18                    | 0.0  | 0.172     | 3.9         | LOS A            | 0.8               | 6.1           | 0.19      | 0.34           | 0.19                | 32.3        |
| Approach                     |      |           | 215                   | 6.4  | 215                   | 6.4  | 0.172     | 2.8         | NA               | 0.8               | 6.1           | 0.19      | 0.34           | 0.19                | 36.7        |
| North: Kent St (N)           |      |           |                       |      |                       |      |           |             |                  |                   |               |           |                |                     |             |
| 7                            | L2   | All MCs   | 15                    | 0.0  | 15                    | 0.0  | 0.037     | 7.1         | LOS A            | 0.1               | 0.9           | 0.31      | 0.89           | 0.31                | 28.2        |
| 8                            | T1   | All MCs   | 16                    | 0.0  | 16                    | 0.0  | 0.037     | 8.4         | LOS A            | 0.1               | 0.9           | 0.31      | 0.89           | 0.31                | 34.0        |
| 9                            | R2   | All MCs   | 4                     | 0.0  | 4                     | 0.0  | 0.037     | 8.3         | LOS A            | 0.1               | 0.9           | 0.31      | 0.89           | 0.31                | 31.3        |
| Approach                     |      |           | 35                    | 0.0  | 35                    | 0.0  | 0.037     | 7.8         | LOS A            | 0.1               | 0.9           | 0.31      | 0.89           | 0.31                | 32.1        |
| West: Argyle PI (W)          |      |           |                       |      |                       |      |           |             |                  |                   |               |           |                |                     |             |
| 10                           | L2   | All MCs   | 1                     | 0.0  | 1                     | 0.0  | 0.101     | 3.4         | LOS A            | 0.5               | 3.4           | 0.24      | 0.33           | 0.24                | 35.4        |
| 11                           | T1   | All MCs   | 55                    | 1.9  | 55                    | 1.9  | 0.101     | 0.4         | LOS A            | 0.5               | 3.4           | 0.24      | 0.33           | 0.24                | 37.0        |
| 12                           | R2   | All MCs   | 74                    | 4.3  | 74                    | 4.3  | 0.101     | 4.3         | LOS A            | 0.5               | 3.4           | 0.24      | 0.33           | 0.24                | 37.5        |
| Approach                     |      |           | 129                   | 3.3  | 129                   | 3.3  | 0.101     | 2.6         | NA               | 0.5               | 3.4           | 0.24      | 0.33           | 0.24                | 37.3        |
| All Vehicles                 |      |           | 693                   | 3.8  | 693                   | 3.8  | 0.360     | 4.3         | NA               | 1.6               | 11.7          | 0.30      | 0.46           | 0.30                | 36.1        |

Site Level of Service (LOS) Method: Delay (RTA NSW). Site LOS Method is specified in the Parameter Settings dialog (Options tab).

Vehicle movement LOS values are based on average delay per movement.

Minor Road Approach LOS values are based on average delay for all vehicle movements.

NA (TWSC): Level of Service is not defined for major road approaches or the intersection as a whole for Two-Way Sign Control (HCM LOS rule).

Two-Way Sign Control Capacity Model: SIDRA Standard.

Delay Model: SIDRA Standard (Control Delay: Geometric Delay is included).

Queue Model: SIDRA queue estimation methods are used for Back of Queue and Queue at Start of Gap.

Gap-Acceptance Capacity Formula: SIDRA Standard (Akçelik M3D).

HV (%) values are calculated for All Movement Classes of All Heavy Vehicle Model Designation.

Arrival Flows used in performance calculations are adjusted to include any Initial Queued Demand and Upstream Capacity Constraint effects.

---

**SIDRA INTERSECTION 9.1 | Copyright © 2000-2022 Akcelik and Associates Pty Ltd | sidrasolutions.com**

Organisation: AECOM AUSTRALIA PTY LTD | Licence: NETWORK / Enterprise Level 1 | Processed: Monday, 17 July 2023 12:15:20 PM

Project: C:\Users\Yeung\AECOMANZ-NAC-Sydney Metro-Sydney Metro C&SW Operational Monitoring - General\400\_Technical\432\_Traffic Analysis\SIDRA Modelling\01 Models (Geometry Only)\Block 1\Rev1\\_Review\04 SM C&SW\_BGU (Block 1)\_PS.sip9

# CCG MOVEMENT SUMMARY

Common Control Group: CCG1 [TCS 4272]

Output produced by SIDRA INTERSECTION Version: 9.1.3.210

Network: BGU-N2 [BGU Network 2 (Network Folder: Block 1 Network - 2023 Weekend Peak)]

EQUISAT (Fixed-Time/SCATS) Coordinated Cycle Time = 65 seconds (CCG User-Given Phase Times)

| Vehicle Movement Performance (CCG)                                       |      |           |              |     |               |     |           |             |                  |                       |                   |           |                |                     |                  |
|--|------|-----------|--------------|-----|---------------|-----|-----------|-------------|------------------|-----------------------|-------------------|-----------|----------------|---------------------|------------------|
| Mov ID   | Turn | Mov Class | Demand Flows |     | Arrival Flows |     | Deg. Satn | Aver. Delay | Level of Service | 95% Back [ Veh. veh ] | Of Queue [ Dist ] | Prop. Que | Eff. Stop Rate | Aver. No. of Cycles | Aver. Speed km/h |
|  |      |           | Total HV ]   | %   | Total HV ]    | %   |           |             |                  |                       |                   |           |                |                     |                  |
| Site: BGU04 [BGU04 Pedestrian Mid-block Crossing at Kent St near Gas Ln] |      |           |              |     |               |     |           |             |                  |                       |                   |           |                |                     |                  |
| South: Kent St   |      |           |              |     |               |     |           |             |                  |                       |                   |           |                |                     |                  |
| 2  | T1   | All MCs   | 264          | 0.0 | 264           | 0.0 | 0.245     | 10.2        | LOS A            | 5.3                   | 37.0              | 0.67      | 0.52           | 0.67                | 32.6             |
| Approach   |      |           | 264          | 0.0 | 264           | 0.0 | 0.245     | 10.2        | LOS A            | 5.3                   | 37.0              | 0.67      | 0.52           | 0.67                | 32.6             |
| North: Kent St   |      |           |              |     |               |     |           |             |                  |                       |                   |           |                |                     |                  |
| 8  | T1   | All MCs   | 233          | 0.9 | 233           | 0.9 | 0.356     | 26.8        | LOS B            | 3.4                   | 24.0              | 0.93      | 0.73           | 0.93                | 24.1             |
| Approach   |      |           | 233          | 0.9 | 233           | 0.9 | 0.356     | 26.8        | LOS B            | 3.4                   | 24.0              | 0.93      | 0.73           | 0.93                | 24.1             |
| All Vehicles   |      |           | 497          | 0.4 | 497           | 0.4 | 0.356     | 18.0        | LOS B            | 5.3                   | 37.0              | 0.79      | 0.62           | 0.79                | 28.2             |
| Site: BGU05 [BGU05 Kent St / Sydney Harbour Bridge (SHB) On-ramp ]       |      |           |              |     |               |     |           |             |                  |                       |                   |           |                |                     |                  |
| South: Kent St (S)   |      |           |              |     |               |     |           |             |                  |                       |                   |           |                |                     |                  |
| 2  | T1   | All MCs   | 188          | 0.0 | 188           | 0.0 | 0.174     | 8.6         | LOS A            | 3.2                   | 22.7              | 0.58      | 0.48           | 0.58                | 28.2             |
| 3a   | R1   | All MCs   | 238          | 0.9 | 238           | 0.9 | *0.434    | 24.1        | LOS B            | 6.2                   | 43.9              | 0.89      | 0.76           | 0.89                | 23.4             |
| Approach   |      |           | 426          | 0.5 | 426           | 0.5 | 0.434     | 17.2        | LOS B            | 6.2                   | 43.9              | 0.75      | 0.64           | 0.75                | 24.8             |
| East: Clarence St (E)  |      |           |              |     |               |     |           |             |                  |                       |                   |           |                |                     |                  |
| 4  | L2   | All MCs   | 24           | 0.0 | 24            | 0.0 | 0.071     | 27.6        | LOS B            | 0.7                   | 4.6               | 0.86      | 0.68           | 0.86                | 14.8             |
| 6  | R2   | All MCs   | 92           | 0.0 | 92            | 0.0 | 0.214     | 25.8        | LOS B            | 2.4                   | 16.9              | 0.85      | 0.73           | 0.85                | 15.4             |
| Approach   |      |           | 116          | 0.0 | 116           | 0.0 | 0.214     | 26.2        | LOS B            | 2.4                   | 16.9              | 0.85      | 0.72           | 0.85                | 15.3             |
| NorthEast: SHB On-ramp (NE)  |      |           |              |     |               |     |           |             |                  |                       |                   |           |                |                     |                  |
| 24a  | L1   | All MCs   | 22           | 0.0 | 22            | 0.0 | 0.020     | 24.5        | LOS B            | 0.6                   | 1.5               | 0.86      | 0.61           | 0.86                | 21.5             |
| Approach   |      |           | 22           | 0.0 | 22            | 0.0 | 0.020     | 24.5        | LOS B            | 0.6                   | 1.5               | 0.86      | 0.61           | 0.86                | 21.5             |
| North: Kent St (N)   |      |           |              |     |               |     |           |             |                  |                       |                   |           |                |                     |                  |
| 7b   | L3   | All MCs   | 103          | 0.0 | 103           | 0.0 | *0.275    | 33.1        | LOS C            | 3.3                   | 23.4              | 1.00      | 0.82           | 1.00                | 14.8             |
| 8  | T1   | All MCs   | 124          | 1.7 | 124           | 1.7 | *0.602    | 27.9        | LOS B            | 3.8                   | 27.1              | 0.94      | 0.75           | 0.96                | 7.1              |
| Approach   |      |           | 227          | 0.9 | 227           | 0.9 | 0.602     | 30.2        | LOS C            | 3.8                   | 27.1              | 0.97      | 0.78           | 0.98                | 11.3             |
| All Vehicles   |      |           | 792          | 0.5 | 792           | 0.5 | 0.602     | 22.5        | LOS B            | 6.2                   | 43.9              | 0.83      | 0.69           | 0.83                | 19.6             |

Site Level of Service (LOS) Method: Delay (RTA NSW). Site LOS Method is specified in the Network Data dialog (Override Site Data tab).

Vehicle movement LOS values are based on average delay per movement.

Intersection and Approach LOS values are based on average delay for all vehicle movements.

Delay Model: SIDRA Standard (Control Delay: Geometric Delay is included).

Gap-Acceptance Capacity Formula: SIDRA Standard (Akçelik M3D).

HV (%) values are calculated for All Movement Classes of All Heavy Vehicle Model Designation.

Arrival Flows used in performance calculations are adjusted to include any Initial Queued Demand and Upstream Capacity Constraint effects.

\* Critical Movement (Signal Timing)

| Pedestrian Movement Performance (CCG)                                    |          |           |             |                  |                       |        |           |                |             |              |             |
|--|----------|-----------|-------------|------------------|-----------------------|--------|-----------|----------------|-------------|--------------|-------------|
| Mov ID   | Crossing | Dem. Flow | Aver. Delay | Level of Service | AVERAGE BACK OF QUEUE |        | Prop. Que | Eff. Stop Rate | Travel Time | Travel Dist. | Aver. Speed |
|  |          | ped/h     | sec         |                  | [ Ped                 | Dist ] |           |                | sec         | m            | m/sec       |
|  |          |           |             |                  | ped                   | m      |           |                |             |              |             |
| Site: BGU04 [BGU04 Pedestrian Mid-block Crossing at Kent St near Gas Ln] |          |           |             |                  |                       |        |           |                |             |              |             |
| South: Kent St   |          |           |             |                  |                       |        |           |                |             |              |             |
| P1   | Full     | 53        | 25.9        | LOS C            | 0.1                   | 0.1    | 0.89      | 0.89           | 192.6       | 200.0        | 1.04        |
| All Pedestrians  |          | 53        | 25.9        | LOS C            | 0.1                   | 0.1    | 0.89      | 0.89           | 192.6       | 200.0        | 1.04        |
| Site: BGU05 [BGU05 Kent St / Sydney Harbour Bridge (SHB) On-ramp ]       |          |           |             |                  |                       |        |           |                |             |              |             |
| South: Kent St (S)   |          |           |             |                  |                       |        |           |                |             |              |             |
| P1   | Full     | 103       | 22.5        | LOS C            | 0.2                   | 0.2    | 0.83      | 0.83           | 39.2        | 20.0         | 0.51        |
| All Pedestrians  |          | 103       | 22.5        | LOS C            | 0.2                   | 0.2    | 0.83      | 0.83           | 39.2        | 20.0         | 0.51        |

Level of Service (LOS) Method: SIDRA Pedestrian LOS Method (Based on Average Delay)  
 Pedestrian movement LOS values are based on average delay per pedestrian movement.  
 Intersection LOS value for Pedestrians is based on average delay for all pedestrian movements.

# MOVEMENT SUMMARY

Site: BGU06 [BGU06 Hickson Rd / Napoleon St / Sussex St  
(Site Folder: Block 1 - 2023 Weekend Peak)]

Output produced by SIDRA INTERSECTION Version: 9.1.3.210

Network: BGU-N2 [BGU  
Network 3 (Network Folder:  
Block 1 Network - 2023  
Weekend Peak)]

TCS 4625

Site Category: (None)

Signals - EQUISAT (Fixed-Time/SCATS) Isolated Cycle Time = 67 seconds (Site User-Given Phase Times)

| Vehicle Movement Performance |      |           |                       |      |                       |      |           |             |                  |                   |               |           |                |                     |                  |
|------------------------------|------|-----------|-----------------------|------|-----------------------|------|-----------|-------------|------------------|-------------------|---------------|-----------|----------------|---------------------|------------------|
| Mov ID                       | Turn | Mov Class | Demand Flows          |      | Arrival Flows         |      | Deg. Satn | Aver. Delay | Level of Service | 95% Back Of Queue |               | Prop. Que | Eff. Stop Rate | Aver. No. of Cycles | Aver. Speed km/h |
|                              |      |           | [ Total HV ]<br>veh/h | %    | [ Total HV ]<br>veh/h | %    |           |             |                  | [ Veh. veh        | [ Dist ]<br>m |           |                |                     |                  |
| South: Sussex St (S)         |      |           |                       |      |                       |      |           |             |                  |                   |               |           |                |                     |                  |
| 2                            | T1   | All MCs   | 318                   | 3.3  | 318                   | 3.3  | 0.322     | 9.9         | LOS A            | 6.0               | 43.0          | 0.61      | 0.52           | 0.61                | 25.5             |
| 3                            | R2   | All MCs   | 48                    | 0.0  | 48                    | 0.0  | *0.133    | 17.2        | LOS B            | 1.0               | 7.0           | 0.76      | 0.68           | 0.76                | 22.9             |
| Approach                     |      |           | 366                   | 2.9  | 366                   | 2.9  | 0.322     | 10.9        | LOS A            | 6.0               | 43.0          | 0.63      | 0.55           | 0.63                | 25.0             |
| East: Napoleon St (E)        |      |           |                       |      |                       |      |           |             |                  |                   |               |           |                |                     |                  |
| 4                            | L2   | All MCs   | 48                    | 19.6 | 48                    | 19.6 | 0.092     | 19.8        | LOS B            | 1.1               | 8.9           | 0.71      | 0.67           | 0.71                | 16.3             |
| 6                            | R2   | All MCs   | 179                   | 3.5  | 179                   | 3.5  | *0.419    | 27.2        | LOS B            | 5.1               | 36.9          | 0.89      | 0.77           | 0.89                | 16.4             |
| Approach                     |      |           | 227                   | 6.9  | 227                   | 6.9  | 0.419     | 25.7        | LOS B            | 5.1               | 36.9          | 0.85      | 0.75           | 0.85                | 16.3             |
| North: Hickson Rd (N)        |      |           |                       |      |                       |      |           |             |                  |                   |               |           |                |                     |                  |
| 7                            | L2   | All MCs   | 140                   | 3.0  | 140                   | 3.0  | 0.227     | 20.6        | LOS B            | 3.3               | 23.7          | 0.75      | 0.72           | 0.75                | 18.7             |
| 8                            | T1   | All MCs   | 288                   | 4.7  | 288                   | 4.7  | *0.415    | 17.1        | LOS B            | 7.1               | 51.7          | 0.79      | 0.67           | 0.79                | 11.8             |
| Approach                     |      |           | 428                   | 4.2  | 428                   | 4.2  | 0.415     | 18.2        | LOS B            | 7.1               | 51.7          | 0.78      | 0.69           | 0.78                | 14.9             |
| West: Car Park Access (W)    |      |           |                       |      |                       |      |           |             |                  |                   |               |           |                |                     |                  |
| 10                           | L2   | All MCs   | 1                     | 0.0  | 1                     | 0.0  | 0.038     | 41.1        | LOS C            | 0.0               | 0.3           | 1.00      | 0.57           | 1.00                | 5.6              |
| 11                           | T1   | All MCs   | 1                     | 0.0  | 1                     | 0.0  | *0.074    | 41.6        | LOS C            | 0.1               | 0.6           | 1.00      | 0.59           | 1.00                | 8.9              |
| 12                           | R2   | All MCs   | 1                     | 0.0  | 1                     | 0.0  | 0.074     | 41.6        | LOS C            | 0.1               | 0.6           | 1.00      | 0.59           | 1.00                | 2.4              |
| Approach                     |      |           | 3                     | 0.0  | 3                     | 0.0  | 0.074     | 41.4        | LOS C            | 0.1               | 0.6           | 1.00      | 0.58           | 1.00                | 5.9              |
| All Vehicles                 |      |           | 1025                  | 4.3  | 1025                  | 4.3  | 0.419     | 17.3        | LOS B            | 7.1               | 51.7          | 0.74      | 0.65           | 0.74                | 18.5             |

Site Level of Service (LOS) Method: Delay (RTA NSW). Site LOS Method is specified in the Network Data dialog (Override Site Data tab).

Vehicle movement LOS values are based on average delay per movement.

Intersection and Approach LOS values are based on average delay for all vehicle movements.

Delay Model: SIDRA Standard (Control Delay: Geometric Delay is included).

Queue Model: SIDRA queue estimation methods are used for Back of Queue and Queue at Start of Green.

Gap-Acceptance Capacity Formula: SIDRA Standard (Akçelik M3D).

HV (%) values are calculated for All Movement Classes of All Heavy Vehicle Model Designation.

Arrival Flows used in performance calculations are adjusted to include any Initial Queued Demand and Upstream Capacity Constraint effects.

\* Critical Movement (Signal Timing)



| Pedestrian Movement Performance |          |           |             |                  |                       |        |           |                |             |              |             |
|---------------------------------|----------|-----------|-------------|------------------|-----------------------|--------|-----------|----------------|-------------|--------------|-------------|
| Mov ID                          | Crossing | Dem. Flow | Aver. Delay | Level of Service | AVERAGE BACK OF QUEUE |        | Prop. Que | Eff. Stop Rate | Travel Time | Travel Dist. | Aver. Speed |
|                                 |          | ped/h     | sec         |                  | [ Ped                 | Dist ] |           |                | sec         | m            | m/sec       |
|                                 |          |           |             |                  | ped                   | m      |           |                |             |              |             |
| South: Sussex St (S)            |          |           |             |                  |                       |        |           |                |             |              |             |
| P1                              | Full     | 14        | 21.0        | LOS C            | 0.0                   | 0.0    | 0.79      | 0.79           | 37.6        | 20.0         | 0.53        |
| East: Napoleon St (E)           |          |           |             |                  |                       |        |           |                |             |              |             |
| P2                              | Full     | 82        | 21.0        | LOS C            | 0.1                   | 0.1    | 0.79      | 0.79           | 37.7        | 20.0         | 0.53        |
| North: Hickson Rd (N)           |          |           |             |                  |                       |        |           |                |             |              |             |
| P3                              | Full     | 24        | 21.0        | LOS C            | 0.0                   | 0.0    | 0.79      | 0.79           | 37.7        | 20.0         | 0.53        |
| West: Car Park Access (W)       |          |           |             |                  |                       |        |           |                |             |              |             |
| P4                              | Full     | 45        | 26.0        | LOS C            | 0.1                   | 0.1    | 0.88      | 0.88           | 42.7        | 20.0         | 0.47        |
| All Pedestrians                 |          | 165       | 22.4        | LOS C            | 0.1                   | 0.1    | 0.82      | 0.82           | 39.1        | 20.0         | 0.51        |

Level of Service (LOS) Method: SIDRA Pedestrian LOS Method (Based on Average Delay)

Pedestrian movement LOS values are based on average delay per pedestrian movement.

Intersection LOS value for Pedestrians is based on average delay for all pedestrian movements.

**SIDRA INTERSECTION 9.1 | Copyright © 2000-2022 Akcelik and Associates Pty Ltd | sidrasolutions.com**

Organisation: AECOM AUSTRALIA PTY LTD | Licence: NETWORK / Enterprise Level 1 | Processed: Monday, 17 July 2023 11:23:58 AM

Project: C:\Users\YeungMA\AECOM\ANZ-NAC-Sydney Metro-Sydney Metro C&SW Operational Monitoring - General\400\_Technical\432\_Traffic Analysis\SIDRA Modelling\01 Models (Geometry Only)\Block 1\Rev1\_Review\04 SM C&SW\_BGU (Block 1)\_PS.sip9

# MOVEMENT SUMMARY

Site: BGU07 [BGU07 Margaret St / Kent St / Napoleon St (Site Folder: Block 1 - 2023 Weekend Peak)]

Output produced by SIDRA INTERSECTION Version: 9.1.3.210

Network: BGU-N2 [BGU Network 2 (Network Folder: Block 1 Network - 2023 Weekend Peak)]

TCS 308

Site Category: (None)

Signals - EQUISAT (Fixed-Time/SCATS) Coordinated Cycle Time = 65 seconds (Network Site User-Given Phase Times)

| Vehicle Movement Performance |      |           |              |      |               |      |           |             |                  |                   |        |           |                |                     |             |
|------------------------------|------|-----------|--------------|------|---------------|------|-----------|-------------|------------------|-------------------|--------|-----------|----------------|---------------------|-------------|
| Mov ID                       | Turn | Mov Class | Demand Flows |      | Arrival Flows |      | Deg. Satn | Aver. Delay | Level of Service | 95% Back Of Queue |        | Prop. Que | Eff. Stop Rate | Aver. No. of Cycles | Aver. Speed |
|                              |      |           | [ Total HV ] | %    | [ Total HV ]  | %    |           |             |                  | [ Veh. veh        | Dist ] |           |                |                     |             |
| South: Kent St (S)           |      |           |              |      |               |      |           |             |                  |                   |        |           |                |                     |             |
| 1a                           | L1   | All MCs   | 46           | 13.6 | 46            | 13.6 | 0.318     | 15.5        | LOS B            | 5.6               | 40.0   | 0.64      | 0.57           | 0.64                | 23.8        |
| 2                            | T1   | All MCs   | 326          | 1.0  | 326           | 1.0  | 0.318     | 13.2        | LOS A            | 5.6               | 40.0   | 0.71      | 0.60           | 0.71                | 11.4        |
| 3                            | R2   | All MCs   | 15           | 0.0  | 15            | 0.0  | *0.318    | 62.2        | LOS E            | 2.6               | 18.1   | 0.93      | 0.73           | 0.93                | 7.2         |
| Approach                     |      |           | 387          | 2.4  | 387           | 2.4  | 0.318     | 15.4        | LOS B            | 5.6               | 40.0   | 0.71      | 0.61           | 0.71                | 13.1        |
| East: Margaret St (E)        |      |           |              |      |               |      |           |             |                  |                   |        |           |                |                     |             |
| 4                            | L2   | All MCs   | 26           | 12.0 | 26            | 12.0 | 0.074     | 26.4        | LOS B            | 0.7               | 5.4    | 0.85      | 0.69           | 0.85                | 10.6        |
| 6a                           | R1   | All MCs   | 168          | 5.0  | 168           | 5.0  | 0.349     | 21.9        | LOS B            | 4.7               | 34.5   | 0.85      | 0.73           | 0.85                | 18.1        |
| 6                            | R2   | All MCs   | 12           | 0.0  | 12            | 0.0  | 0.349     | 23.9        | LOS B            | 4.7               | 34.5   | 0.85      | 0.73           | 0.85                | 8.7         |
| Approach                     |      |           | 206          | 5.6  | 206           | 5.6  | 0.349     | 22.6        | LOS B            | 4.7               | 34.5   | 0.85      | 0.72           | 0.85                | 16.8        |
| North: Kent St (N)           |      |           |              |      |               |      |           |             |                  |                   |        |           |                |                     |             |
| 7                            | L2   | All MCs   | 35           | 0.0  | 35            | 0.0  | 0.335     | 48.4        | LOS D            | 4.0               | 28.0   | 0.92      | 0.75           | 0.92                | 17.4        |
| 8                            | T1   | All MCs   | 126          | 0.0  | 126           | 0.0  | *0.335    | 20.4        | LOS B            | 4.0               | 28.0   | 0.94      | 0.74           | 0.94                | 18.9        |
| 9b                           | R3   | All MCs   | 22           | 19.0 | 22            | 19.0 | 0.092     | 10.7        | LOS A            | 0.2               | 1.4    | 0.24      | 0.56           | 0.24                | 29.3        |
| Approach                     |      |           | 183          | 2.3  | 183           | 2.3  | 0.335     | 24.5        | LOS B            | 4.0               | 28.0   | 0.85      | 0.72           | 0.85                | 19.8        |
| NorthWest: Napoleon St (NW)  |      |           |              |      |               |      |           |             |                  |                   |        |           |                |                     |             |
| 27b                          | L3   | All MCs   | 116          | 3.6  | 116           | 3.6  | 0.261     | 8.3         | LOS A            | 2.9               | 20.6   | 0.65      | 0.68           | 0.65                | 23.3        |
| 27a                          | L1   | All MCs   | 72           | 1.5  | 72            | 1.5  | *0.261    | 15.1        | LOS B            | 2.9               | 20.6   | 0.65      | 0.68           | 0.65                | 23.3        |
| Approach                     |      |           | 187          | 2.8  | 187           | 2.8  | 0.261     | 10.9        | LOS A            | 2.9               | 20.6   | 0.65      | 0.68           | 0.65                | 23.3        |
| All Vehicles                 |      |           | 964          | 3.2  | 964           | 3.2  | 0.349     | 17.8        | LOS B            | 5.6               | 40.0   | 0.76      | 0.67           | 0.76                | 17.6        |

Site Level of Service (LOS) Method: Delay (RTA NSW). Site LOS Method is specified in the Network Data dialog (Override Site Data tab).

Vehicle movement LOS values are based on average delay per movement.

Intersection and Approach LOS values are based on average delay for all vehicle movements.

Delay Model: SIDRA Standard (Control Delay: Geometric Delay is included).

Queue Model: SIDRA queue estimation methods are used for Back of Queue and Queue at Start of Green.

Gap-Acceptance Capacity Formula: SIDRA Standard (Akçelik M3D).

HV (%) values are calculated for All Movement Classes of All Heavy Vehicle Model Designation.

Arrival Flows used in performance calculations are adjusted to include any Initial Queued Demand and Upstream Capacity Constraint effects.

\* Critical Movement (Signal Timing)

| Pedestrian Movement Performance |          |           |             |                  |                       |        |           |                |             |              |             |
|---------------------------------|----------|-----------|-------------|------------------|-----------------------|--------|-----------|----------------|-------------|--------------|-------------|
| Mov ID                          | Crossing | Dem. Flow | Aver. Delay | Level of Service | AVERAGE BACK OF QUEUE |        | Prop. Que | Eff. Stop Rate | Travel Time | Travel Dist. | Aver. Speed |
|                                 |          | ped/h     | sec         |                  | [ Ped                 | Dist ] |           |                | sec         | m            | m/sec       |
|                                 |          |           |             |                  | ped                   | m      |           |                |             |              |             |
| South: Kent St (S)              |          |           |             |                  |                       |        |           |                |             |              |             |
| P1                              | Full     | 161       | 20.1        | LOS C            | 0.2                   | 0.2    | 0.79      | 0.79           | 36.8        | 20.0         | 0.54        |
| East: Margaret St (E)           |          |           |             |                  |                       |        |           |                |             |              |             |
| P2                              | Full     | 28        | 24.2        | LOS C            | 0.0                   | 0.0    | 0.86      | 0.86           | 40.8        | 20.0         | 0.49        |
| North: Kent St (N)              |          |           |             |                  |                       |        |           |                |             |              |             |
| P3                              | Full     | 28        | 19.3        | LOS B            | 0.0                   | 0.0    | 0.77      | 0.77           | 35.9        | 20.0         | 0.56        |
| NorthWest: Napoleon St (NW)     |          |           |             |                  |                       |        |           |                |             |              |             |
| P7                              | Full     | 82        | 19.3        | LOS B            | 0.1                   | 0.1    | 0.77      | 0.77           | 186.0       | 200.0        | 1.08        |
| All Pedestrians                 |          | 300       | 20.2        | LOS C            | 0.2                   | 0.2    | 0.79      | 0.79           | 77.9        | 69.3         | 0.89        |

Level of Service (LOS) Method: SIDRA Pedestrian LOS Method (Based on Average Delay)

Pedestrian movement LOS values are based on average delay per pedestrian movement.

Intersection LOS value for Pedestrians is based on average delay for all pedestrian movements.

**SIDRA INTERSECTION 9.1 | Copyright © 2000-2022 Akcelik and Associates Pty Ltd | sidrasolutions.com**

Organisation: AECOM AUSTRALIA PTY LTD | Licence: NETWORK / Enterprise Level 1 | Processed: Monday, 17 July 2023 11:58:47 AM

Project: C:\Users\YeungMA\AECOM\ANZ-NAC-Sydney Metro-Sydney Metro C&SW Operational Monitoring - General\400\_Technical\432\_Traffic Analysis\SIDRA Modelling\01 Models (Geometry Only)\Block 1\Rev1\_Review\04 SM C&SW\_BGU (Block 1)\_PS.sip9

# MOVEMENT SUMMARY

Site: BGU08 [BGU08 Margaret St / Clarence St (Site Folder: Block 1 - 2023 Weekend Peak)]

Output produced by SIDRA INTERSECTION Version: 9.1.3.210

Network: BGU-N2 [BGU Network 2 (Network Folder: Block 1 Network - 2023 Weekend Peak)]

TCS 319

Site Category: NA

Signals - EQUISAT (Fixed-Time/SCATS) Coordinated Cycle Time = 65 seconds (Network User-Given Cycle Time)

| Vehicle Movement Performance |      |           |                       |      |                       |      |           |             |                  |                   |               |           |                |                     |                  |
|------------------------------|------|-----------|-----------------------|------|-----------------------|------|-----------|-------------|------------------|-------------------|---------------|-----------|----------------|---------------------|------------------|
| Mov ID                       | Turn | Mov Class | Demand Flows          |      | Arrival Flows         |      | Deg. Satn | Aver. Delay | Level of Service | 95% Back Of Queue |               | Prop. Que | Eff. Stop Rate | Aver. No. of Cycles | Aver. Speed km/h |
|                              |      |           | [ Total HV ]<br>veh/h | %    | [ Total HV ]<br>veh/h | %    |           |             |                  | [ Veh. veh        | [ Dist ]<br>m |           |                |                     |                  |
| South: Clarence St (S)       |      |           |                       |      |                       |      |           |             |                  |                   |               |           |                |                     |                  |
| 1                            | L2   | All MCs   | 20                    | 0.0  | 20                    | 0.0  | 0.334     | 20.4        | LOS B            | 4.1               | 29.3          | 0.74      | 0.62           | 0.74                | 19.2             |
| 2                            | T1   | All MCs   | 404                   | 12.5 | 404                   | 12.5 | *0.334    | 15.9        | LOS B            | 4.7               | 33.3          | 0.75      | 0.62           | 0.75                | 22.2             |
| 3                            | R2   | All MCs   | 0                     | 0.0  | 0                     | 0.0  | 0.000     | 0.0         | NA               | 0.0               | 0.0           | 0.00      | 0.00           | 0.00                | 0.0              |
| Approach                     |      |           | 424                   | 11.9 | 424                   | 11.9 | 0.334     | 16.1        | LOS B            | 4.7               | 33.3          | 0.75      | 0.62           | 0.75                | 22.1             |
| East: Margaret St (E)        |      |           |                       |      |                       |      |           |             |                  |                   |               |           |                |                     |                  |
| 5                            | T1   | All MCs   | 185                   | 6.3  | 185                   | 6.3  | 0.169     | 11.8        | LOS A            | 2.6               | 19.4          | 0.65      | 0.54           | 0.65                | 12.3             |
| 6                            | R2   | All MCs   | 40                    | 31.6 | 40                    | 31.6 | *0.169    | 16.8        | LOS B            | 1.7               | 14.1          | 0.72      | 0.63           | 0.72                | 15.8             |
| Approach                     |      |           | 225                   | 10.7 | 225                   | 10.7 | 0.169     | 12.7        | LOS A            | 2.6               | 19.4          | 0.67      | 0.56           | 0.67                | 13.2             |
| West: Margaret St (W)        |      |           |                       |      |                       |      |           |             |                  |                   |               |           |                |                     |                  |
| 10                           | L2   | All MCs   | 81                    | 0.0  | 81                    | 0.0  | 0.277     | 27.6        | LOS B            | 3.5               | 24.8          | 0.90      | 0.75           | 0.90                | 11.2             |
| 11                           | T1   | All MCs   | 44                    | 2.4  | 44                    | 2.4  | *0.277    | 22.5        | LOS B            | 3.5               | 24.8          | 0.90      | 0.75           | 0.90                | 6.5              |
| Approach                     |      |           | 125                   | 0.8  | 125                   | 0.8  | 0.277     | 25.8        | LOS B            | 3.5               | 24.8          | 0.90      | 0.75           | 0.90                | 9.7              |
| All Vehicles                 |      |           | 775                   | 9.8  | 792                   | 9.6  | 0.334     | 16.3        | LOS B            | 4.7               | 33.3          | 0.73      | 0.61           | 0.73                | 18.2             |

Site Level of Service (LOS) Method: Delay (RTA NSW). Site LOS Method is specified in the Network Data dialog (Override Site Data tab).

Vehicle movement LOS values are based on average delay per movement.

Intersection and Approach LOS values are based on average delay for all vehicle movements.

Delay Model: SIDRA Standard (Control Delay: Geometric Delay is included).

Queue Model: SIDRA queue estimation methods are used for Back of Queue and Queue at Start of Green.

Gap-Acceptance Capacity Formula: SIDRA Standard (Akçelik M3D).

HV (%) values are calculated for All Movement Classes of All Heavy Vehicle Model Designation.

Arrival Flows used in performance calculations are adjusted to include any Initial Queued Demand and Upstream Capacity Constraint effects.

\* Critical Movement (Signal Timing)

| Pedestrian Movement Performance |          |           |             |                  |                       |        |           |                |             |              |             |
|---------------------------------|----------|-----------|-------------|------------------|-----------------------|--------|-----------|----------------|-------------|--------------|-------------|
| Mov ID                          | Crossing | Dem. Flow | Aver. Delay | Level of Service | AVERAGE BACK OF QUEUE |        | Prop. Que | Eff. Stop Rate | Travel Time | Travel Dist. | Aver. Speed |
|                                 |          | ped/h     | sec         |                  | [ Ped                 | Dist ] |           |                | sec         | m            | m/sec       |
|                                 |          |           |             |                  | ped                   | m      |           |                |             |              |             |
| South: Clarence St (S)          |          |           |             |                  |                       |        |           |                |             |              |             |
| P1                              | Full     | 173       | 25.2        | LOS C            | 0.3                   | 0.3    | 0.88      | 0.88           | 41.8        | 20.0         | 0.48        |
| East: Margaret St (E)           |          |           |             |                  |                       |        |           |                |             |              |             |
| P2                              | Full     | 53        | 25.0        | LOS C            | 0.1                   | 0.1    | 0.88      | 0.88           | 41.7        | 20.0         | 0.48        |
| North: Clarence St (N)          |          |           |             |                  |                       |        |           |                |             |              |             |
| P3                              | Full     | 54        | 23.3        | LOS C            | 0.1                   | 0.1    | 0.85      | 0.85           | 40.0        | 20.0         | 0.50        |
| West: Margaret St (W)           |          |           |             |                  |                       |        |           |                |             |              |             |
| P4                              | Full     | 53        | 20.8        | LOS C            | 0.1                   | 0.1    | 0.80      | 0.80           | 37.5        | 20.0         | 0.53        |
| All Pedestrians                 |          | 332       | 24.2        | LOS C            | 0.3                   | 0.3    | 0.86      | 0.86           | 40.8        | 20.0         | 0.49        |

Level of Service (LOS) Method: SIDRA Pedestrian LOS Method (Based on Average Delay)

Pedestrian movement LOS values are based on average delay per pedestrian movement.

Intersection LOS value for Pedestrians is based on average delay for all pedestrian movements.

**SIDRA INTERSECTION 9.1 | Copyright © 2000-2022 Akcelik and Associates Pty Ltd | sidrasolutions.com**

Organisation: AECOM AUSTRALIA PTY LTD | Licence: NETWORK / Enterprise Level 1 | Processed: Monday, 17 July 2023 11:58:47 AM

Project: C:\Users\YeungMA\AECOM\ANZ-NAC-Sydney Metro-Sydney Metro C&SW Operational Monitoring - General\400\_Technical\432\_Traffic Analysis\SIDRA Modelling\01 Models (Geometry Only)\Block 1\Rev1\_Review\04 SM C&SW\_BGU (Block 1)\_PS.sip9

# MOVEMENT SUMMARY

Site: BGU09 [BGU09 Margaret St / York St (Site Folder: Block 1 - 2023 Weekend Peak)]

Output produced by SIDRA INTERSECTION Version: 9.1.3.210

Network: BGU-N2 [BGU Network 2 (Network Folder: Block 1 Network - 2023 Weekend Peak)]

TCS 3042

Site Category: NA

Signals - EQUISAT (Fixed-Time/SCATS) Isolated Cycle Time = 80 seconds (Site User-Given Phase Times)

| Vehicle Movement Performance |      |           |                       |      |                       |      |           |             |                  |                   |               |           |                |                     |             |
|------------------------------|------|-----------|-----------------------|------|-----------------------|------|-----------|-------------|------------------|-------------------|---------------|-----------|----------------|---------------------|-------------|
| Mov ID                       | Turn | Mov Class | Demand Flows          |      | Arrival Flows         |      | Deg. Satn | Aver. Delay | Level of Service | 95% Back Of Queue |               | Prop. Que | Eff. Stop Rate | Aver. No. of Cycles | Aver. Speed |
|                              |      |           | [ Total HV ]<br>veh/h | %    | [ Total HV ]<br>veh/h | %    |           |             |                  | [ Veh. veh        | [ Dist ]<br>m |           |                |                     |             |
| East: Margaret St (E)        |      |           |                       |      |                       |      |           |             |                  |                   |               |           |                |                     |             |
| 4                            | L2   | All MCs   | 42                    | 5.0  | 42                    | 5.0  | 0.091     | 27.6        | LOS B            | 1.3               | 9.1           | 0.79      | 0.69           | 0.79                | 16.6        |
| 5                            | T1   | All MCs   | 37                    | 42.9 | 37                    | 42.9 | 0.077     | 18.9        | LOS B            | 1.0               | 9.3           | 0.70      | 0.53           | 0.70                | 11.0        |
| Approach                     |      |           | 79                    | 22.7 | 79                    | 22.7 | 0.091     | 23.5        | LOS B            | 1.3               | 9.3           | 0.75      | 0.61           | 0.75                | 14.8        |
| North: York St (N)           |      |           |                       |      |                       |      |           |             |                  |                   |               |           |                |                     |             |
| 7                            | L2   | All MCs   | 1                     | 0.0  | 1                     | 0.0  | 0.000     | 16.7        | LOS B            | 0.0               | 0.1           | 0.61      | 0.48           | 0.61                | 15.2        |
| 8                            | T1   | All MCs   | 622                   | 9.0  | 622                   | 9.0  | *0.238    | 12.8        | LOS A            | 4.7               | 35.3          | 0.62      | 0.52           | 0.62                | 24.9        |
| 9                            | R2   | All MCs   | 178                   | 4.7  | 178                   | 4.7  | 0.224     | 18.4        | LOS B            | 4.2               | 30.9          | 0.65      | 0.73           | 0.65                | 11.3        |
| Approach                     |      |           | 801                   | 8.0  | 801                   | 8.0  | 0.238     | 14.0        | LOS A            | 4.7               | 35.3          | 0.62      | 0.56           | 0.62                | 22.4        |
| West: Margaret St (W)        |      |           |                       |      |                       |      |           |             |                  |                   |               |           |                |                     |             |
| 12                           | R2   | All MCs   | 67                    | 1.6  | 51                    | 2.1  | *0.139    | 28.9        | LOS C            | 1.6               | 11.2          | 0.81      | 0.71           | 0.81                | 15.0        |
| Approach                     |      |           | 67                    | 1.6  | 51                    | 2.1  | 0.139     | 28.9        | LOS C            | 1.6               | 11.2          | 0.81      | 0.71           | 0.81                | 15.0        |
| All Vehicles                 |      |           | 947                   | 8.8  | 931                   | 8.9  | 0.238     | 15.6        | LOS B            | 4.7               | 35.3          | 0.64      | 0.58           | 0.64                | 21.1        |

Site Level of Service (LOS) Method: Delay (RTA NSW). Site LOS Method is specified in the Network Data dialog (Override Site Data tab).

Vehicle movement LOS values are based on average delay per movement.

Intersection and Approach LOS values are based on average delay for all vehicle movements.

Delay Model: SIDRA Standard (Control Delay: Geometric Delay is included).

Queue Model: SIDRA queue estimation methods are used for Back of Queue and Queue at Start of Green.

Gap-Acceptance Capacity Formula: SIDRA Standard (Akçelik M3D).

HV (%) values are calculated for All Movement Classes of All Heavy Vehicle Model Designation.

Arrival Flows used in performance calculations are adjusted to include any Initial Queued Demand and Upstream Capacity Constraint effects.

\* Critical Movement (Signal Timing)

| Pedestrian Movement Performance |          |           |             |                  |                       |        |           |                |             |              |             |
|---------------------------------|----------|-----------|-------------|------------------|-----------------------|--------|-----------|----------------|-------------|--------------|-------------|
| Mov ID                          | Crossing | Dem. Flow | Aver. Delay | Level of Service | AVERAGE BACK OF QUEUE |        | Prop. Que | Eff. Stop Rate | Travel Time | Travel Dist. | Aver. Speed |
|                                 |          | ped/h     | sec         |                  | [ Ped                 | Dist ] |           |                | sec         | m            | m/sec       |
|                                 |          |           |             |                  | ped                   | m      |           |                |             |              |             |
| South: York St (S)              |          |           |             |                  |                       |        |           |                |             |              |             |
| P1                              | Full     | 174       | 28.3        | LOS C            | 0.3                   | 0.3    | 0.84      | 0.84           | 44.9        | 20.0         | 0.45        |
| East: Margaret St (E)           |          |           |             |                  |                       |        |           |                |             |              |             |
| P2                              | Full     | 277       | 28.4        | LOS C            | 0.5                   | 0.5    | 0.85      | 0.85           | 45.1        | 20.0         | 0.44        |
| North: York St (N)              |          |           |             |                  |                       |        |           |                |             |              |             |
| P3                              | Full     | 96        | 26.5        | LOS C            | 0.2                   | 0.2    | 0.82      | 0.82           | 43.2        | 20.0         | 0.46        |
| West: Margaret St (W)           |          |           |             |                  |                       |        |           |                |             |              |             |
| P4                              | Full     | 189       | 30.9        | LOS D            | 0.4                   | 0.4    | 0.88      | 0.88           | 47.5        | 20.0         | 0.42        |
| All Pedestrians                 |          | 736       | 28.8        | LOS C            | 0.5                   | 0.5    | 0.85      | 0.85           | 45.4        | 20.0         | 0.44        |

Level of Service (LOS) Method: SIDRA Pedestrian LOS Method (Based on Average Delay)

Pedestrian movement LOS values are based on average delay per pedestrian movement.

Intersection LOS value for Pedestrians is based on average delay for all pedestrian movements.

**SIDRA INTERSECTION 9.1 | Copyright © 2000-2022 Akcelik and Associates Pty Ltd | sidrasolutions.com**

Organisation: AECOM AUSTRALIA PTY LTD | Licence: NETWORK / Enterprise Level 1 | Processed: Monday, 17 July 2023 11:58:47 AM

Project: C:\Users\YeungMA\AECOM\ANZ-NAC-Sydney Metro-Sydney Metro C&SW Operational Monitoring - General\400\_Technical\432\_Traffic Analysis\SIDRA Modelling\01 Models (Geometry Only)\Block 1\Rev1\_Review\04 SM C&SW\_BGU (Block 1)\_PS.sip9

# MOVEMENT SUMMARY

 Site: BGU10 [BGU10 Pedestrian Mid-block Crossing at Sussex St under Exchange PI (Site Folder: Block 1 - 2023 Weekend Peak)]

 Network: BGU-N2 [BGU Network 3 (Network Folder: Block 1 Network - 2023 Weekend Peak)]

Output produced by SIDRA INTERSECTION Version: 9.1.3.210

TCS 3939 (?)

Site Category: (None)

Pedestrian Crossing (Signalised) - EQUISAT (Fixed-Time/SCATS) Isolated Cycle Time = 70 seconds (Site User-Given Phase Times)

| Vehicle Movement Performance |      |           |              |     |               |     |           |             |                  |                   |          |           |                |                     |             |
|------------------------------|------|-----------|--------------|-----|---------------|-----|-----------|-------------|------------------|-------------------|----------|-----------|----------------|---------------------|-------------|
| Mov ID                       | Turn | Mov Class | Demand Flows |     | Arrival Flows |     | Deg. Satn | Aver. Delay | Level of Service | 95% Back Of Queue |          | Prop. Que | Eff. Stop Rate | Aver. No. of Cycles | Aver. Speed |
|                              |      |           | [ Total HV ] | %   | [ Total HV ]  | %   |           |             |                  | [ Veh. veh        | Dist ] m |           |                |                     |             |
| South: Sussex St (S)         |      |           |              |     |               |     |           |             |                  |                   |          |           |                |                     |             |
| 2                            | T1   | All MCs   | 365          | 3.5 | 365           | 3.5 | *0.130    | 2.7         | LOS A            | 1.8               | 12.6     | 0.30      | 0.25           | 0.30                | 33.3        |
| Approach                     |      |           | 365          | 3.5 | 365           | 3.5 | 0.130     | 2.7         | LOS A            | 1.8               | 12.6     | 0.30      | 0.25           | 0.30                | 33.3        |
| North: Sussex St (N)         |      |           |              |     |               |     |           |             |                  |                   |          |           |                |                     |             |
| 8                            | T1   | All MCs   | 289          | 8.0 | 289           | 8.0 | 0.108     | 2.7         | LOS A            | 1.4               | 10.2     | 0.30      | 0.24           | 0.30                | 32.3        |
| Approach                     |      |           | 289          | 8.0 | 289           | 8.0 | 0.108     | 2.7         | LOS A            | 1.4               | 10.2     | 0.30      | 0.24           | 0.30                | 32.3        |
| All Vehicles                 |      |           | 655          | 5.5 | 655           | 5.5 | 0.130     | 2.7         | LOS A            | 1.8               | 12.6     | 0.30      | 0.25           | 0.30                | 32.9        |

Site Level of Service (LOS) Method: Delay (RTA NSW). Site LOS Method is specified in the Network Data dialog (Override Site Data tab).

Vehicle movement LOS values are based on average delay per movement.

Intersection and Approach LOS values are based on average delay for all vehicle movements.

Delay Model: SIDRA Standard (Control Delay: Geometric Delay is included).

Queue Model: SIDRA queue estimation methods are used for Back of Queue and Queue at Start of Green.

Gap-Acceptance Capacity Formula: SIDRA Standard (Akçelik M3D).

HV (%) values are calculated for All Movement Classes of All Heavy Vehicle Model Designation.

Arrival Flows used in performance calculations are adjusted to include any Initial Queued Demand and Upstream Capacity Constraint effects.

\* Critical Movement (Signal Timing)



| Pedestrian Movement Performance |          |           |             |                  |                       |        |           |                |             |              |             |
|---------------------------------|----------|-----------|-------------|------------------|-----------------------|--------|-----------|----------------|-------------|--------------|-------------|
| Mov ID                          | Crossing | Dem. Flow | Aver. Delay | Level of Service | AVERAGE BACK OF QUEUE |        | Prop. Que | Eff. Stop Rate | Travel Time | Travel Dist. | Aver. Speed |
|                                 |          | ped/h     | sec         |                  | [ Ped                 | Dist ] |           |                | sec         | m            | m/sec       |
|                                 |          |           |             |                  | ped                   | m      |           |                |             |              |             |
| South: Sussex St (S)            |          |           |             |                  |                       |        |           |                |             |              |             |
| P1                              | Full     | 62        | 24.1        | LOS C            | 0.1                   | 0.1    | 0.83      | 0.83           | 40.8        | 20.0         | 0.49        |
| All Pedestrians                 |          | 62        | 24.1        | LOS C            | 0.1                   | 0.1    | 0.83      | 0.83           | 40.8        | 20.0         | 0.49        |

Level of Service (LOS) Method: SIDRA Pedestrian LOS Method (Based on Average Delay)

Pedestrian movement LOS values are based on average delay per pedestrian movement.

Intersection LOS value for Pedestrians is based on average delay for all pedestrian movements.

---

**SIDRA INTERSECTION 9.1 | Copyright © 2000-2022 Akcelik and Associates Pty Ltd | sidrasolutions.com**

Organisation: AECOM AUSTRALIA PTY LTD | Licence: NETWORK / Enterprise Level 1 | Processed: Monday, 17 July 2023 11:23:58 AM

Project: C:\Users\YeungM\AECOM\ANZ-NAC-Sydney Metro-Sydney Metro C&SW Operational Monitoring - General\400\_Technical\432\_Traffic Analysis\SIDRA Modelling\01 Models (Geometry Only)\Block 1\Rev1\\_Review\04 SM C&SW\_BGU (Block 1)\_PS.sip9

# MOVEMENT SUMMARY

 Site: **BGU11 [BGU11 Pedestrian Mid-block Crossing at Kent St near Margaret St (Site Folder: Block 1 - 2023 Weekend Peak)]**

Output produced by SIDRA INTERSECTION Version: 9.1.3.210

 Network: **BGU-N2 [BGU Network 3 (Network Folder: Block 1 Network - 2023 Weekend Peak)]**

TCS 4109

Site Category: (None)

Pedestrian Crossing (Signalised) - EQUISAT (Fixed-Time/SCATS) Isolated Cycle Time = 45 seconds (Site User-Given Phase Times)

| Vehicle Movement Performance |      |           |                       |     |                       |     |           |             |                  |                   |               |           |                |                     |             |
|------------------------------|------|-----------|-----------------------|-----|-----------------------|-----|-----------|-------------|------------------|-------------------|---------------|-----------|----------------|---------------------|-------------|
| Mov ID                       | Turn | Mov Class | Demand Flows          |     | Arrival Flows         |     | Deg. Satn | Aver. Delay | Level of Service | 95% Back Of Queue |               | Prop. Que | Eff. Stop Rate | Aver. No. of Cycles | Aver. Speed |
|                              |      |           | [ Total HV ]<br>veh/h | %   | [ Total HV ]<br>veh/h | %   |           |             |                  | [ Veh. veh        | [ Dist ]<br>m |           |                |                     |             |
| South: Kent St (S)           |      |           |                       |     |                       |     |           |             |                  |                   |               |           |                |                     |             |
| 2                            | T1   | All MCs   | 397                   | 2.9 | 397                   | 2.9 | *0.242    | 9.2         | LOS A            | 2.8               | 20.0          | 0.68      | 0.55           | 0.68                | 23.4        |
| Approach                     |      |           | 397                   | 2.9 | 397                   | 2.9 | 0.242     | 9.2         | LOS A            | 2.8               | 20.0          | 0.68      | 0.55           | 0.68                | 23.4        |
| North: Kent St (N)           |      |           |                       |     |                       |     |           |             |                  |                   |               |           |                |                     |             |
| 8                            | T1   | All MCs   | 184                   | 4.6 | 184                   | 4.6 | 0.207     | 8.9         | LOS A            | 2.3               | 16.8          | 0.66      | 0.53           | 0.66                | 15.6        |
| Approach                     |      |           | 184                   | 4.6 | 184                   | 4.6 | 0.207     | 8.9         | LOS A            | 2.3               | 16.8          | 0.66      | 0.53           | 0.66                | 15.6        |
| All Vehicles                 |      |           | 581                   | 3.4 | 581                   | 3.4 | 0.242     | 9.1         | LOS A            | 2.8               | 20.0          | 0.67      | 0.55           | 0.67                | 21.5        |

Site Level of Service (LOS) Method: Delay (RTA NSW). Site LOS Method is specified in the Network Data dialog (Override Site Data tab).

Vehicle movement LOS values are based on average delay per movement.

Intersection and Approach LOS values are based on average delay for all vehicle movements.

Delay Model: SIDRA Standard (Control Delay: Geometric Delay is included).

Queue Model: SIDRA queue estimation methods are used for Back of Queue and Queue at Start of Green.

Gap-Acceptance Capacity Formula: SIDRA Standard (Akçelik M3D).

HV (%) values are calculated for All Movement Classes of All Heavy Vehicle Model Designation.

Arrival Flows used in performance calculations are adjusted to include any Initial Queued Demand and Upstream Capacity Constraint effects.

\* Critical Movement (Signal Timing)

| Pedestrian Movement Performance |          |           |             |                  |                       |        |           |                |             |              |             |
|---------------------------------|----------|-----------|-------------|------------------|-----------------------|--------|-----------|----------------|-------------|--------------|-------------|
| Mov ID                          | Crossing | Dem. Flow | Aver. Delay | Level of Service | AVERAGE BACK OF QUEUE |        | Prop. Que | Eff. Stop Rate | Travel Time | Travel Dist. | Aver. Speed |
|                                 |          | ped/h     | sec         |                  | [ Ped                 | Dist ] |           |                | sec         | m            | m/sec       |
|                                 |          |           |             |                  | ped                   | m      |           |                |             |              |             |
| South: Kent St (S)              |          |           |             |                  |                       |        |           |                |             |              |             |
| P1                              | Full     | 14        | 12.1        | LOS B            | 0.0                   | 0.0    | 0.73      | 0.73           | 28.8        | 20.0         | 0.70        |
| All Pedestrians                 |          | 14        | 12.1        | LOS B            | 0.0                   | 0.0    | 0.73      | 0.73           | 28.8        | 20.0         | 0.70        |

Level of Service (LOS) Method: SIDRA Pedestrian LOS Method (Based on Average Delay)

Pedestrian movement LOS values are based on average delay per pedestrian movement.

Intersection LOS value for Pedestrians is based on average delay for all pedestrian movements.

---

**SIDRA INTERSECTION 9.1 | Copyright © 2000-2022 Akcelik and Associates Pty Ltd | sidrasolutions.com**

Organisation: AECOM AUSTRALIA PTY LTD | Licence: NETWORK / Enterprise Level 1 | Processed: Monday, 17 July 2023 11:23:58 AM

Project: C:\Users\YeungM\AECOM\ANZ-NAC-Sydney Metro-Sydney Metro C&SW Operational Monitoring - General\400\_Technical\432\_Traffic Analysis\SIDRA Modelling\01 Models (Geometry Only)\Block 1\Rev1\\_Review\04 SM C&SW\_BGU (Block 1)\_PS.sip9

# MOVEMENT SUMMARY

Site: BGU12 [BGU12 Sussex St / Erskine St (Site Folder: Block 1 - 2023 Weekend Peak)]

Output produced by SIDRA INTERSECTION Version: 9.1.3.210

Network: BGU-N2 [BGU Network 3 (Network Folder: Block 1 Network - 2023 Weekend Peak)]

TCS 310

Site Category: (None)

Signals - EQUISAT (Fixed-Time/SCATS) Coordinated Cycle Time = 90 seconds (Network Site User-Given Phase Times)

| Vehicle Movement Performance |      |           |              |      |               |      |           |             |                  |                   |        |           |                |                     |             |
|------------------------------|------|-----------|--------------|------|---------------|------|-----------|-------------|------------------|-------------------|--------|-----------|----------------|---------------------|-------------|
| Mov ID                       | Turn | Mov Class | Demand Flows |      | Arrival Flows |      | Deg. Satn | Aver. Delay | Level of Service | 95% Back Of Queue |        | Prop. Que | Eff. Stop Rate | Aver. No. of Cycles | Aver. Speed |
|                              |      |           | [ Total HV ] | %    | [ Total HV ]  | %    |           |             |                  | [ Veh. veh        | Dist ] |           |                |                     |             |
| South: Sussex St (S)         |      |           |              |      |               |      |           |             |                  |                   |        |           |                |                     |             |
| 1                            | L2   | All MCs   | 66           | 0.0  | 66            | 0.0  | 0.278     | 30.4        | LOS C            | 5.1               | 36.4   | 0.81      | 0.70           | 0.81                | 16.3        |
| 2                            | T1   | All MCs   | 242          | 3.5  | 242           | 3.5  | *0.278    | 25.8        | LOS B            | 5.3               | 38.3   | 0.81      | 0.67           | 0.81                | 16.7        |
| Approach                     |      |           | 308          | 2.7  | 308           | 2.7  | 0.278     | 26.8        | LOS B            | 5.3               | 38.3   | 0.81      | 0.68           | 0.81                | 16.6        |
| East: Erskine St (E)         |      |           |              |      |               |      |           |             |                  |                   |        |           |                |                     |             |
| 4                            | L2   | All MCs   | 365          | 1.7  | 365           | 1.7  | 0.401     | 10.7        | LOS A            | 6.0               | 42.3   | 0.40      | 0.62           | 0.40                | 27.1        |
| 5                            | T1   | All MCs   | 133          | 4.0  | 133           | 4.0  | 0.226     | 2.7         | LOS A            | 1.1               | 8.0    | 0.15      | 0.22           | 0.15                | 27.0        |
| 6                            | R2   | All MCs   | 42           | 0.0  | 42            | 0.0  | 0.226     | 7.2         | LOS A            | 1.1               | 8.0    | 0.15      | 0.22           | 0.15                | 27.0        |
| Approach                     |      |           | 540          | 2.1  | 540           | 2.1  | 0.401     | 8.5         | LOS A            | 6.0               | 42.3   | 0.32      | 0.49           | 0.32                | 27.1        |
| North: Sussex St (N)         |      |           |              |      |               |      |           |             |                  |                   |        |           |                |                     |             |
| 7                            | L2   | All MCs   | 20           | 36.8 | 20            | 36.8 | 0.041     | 23.5        | LOS B            | 0.6               | 5.2    | 0.67      | 0.64           | 0.67                | 15.1        |
| 8                            | T1   | All MCs   | 280          | 5.6  | 280           | 5.6  | 0.201     | 20.2        | LOS B            | 4.1               | 30.3   | 0.71      | 0.58           | 0.71                | 24.4        |
| 9                            | R2   | All MCs   | 15           | 0.0  | 15            | 0.0  | *0.047    | 26.6        | LOS B            | 0.5               | 3.2    | 0.78      | 0.66           | 0.78                | 13.8        |
| Approach                     |      |           | 315          | 7.4  | 315           | 7.4  | 0.201     | 20.8        | LOS B            | 4.1               | 30.3   | 0.71      | 0.59           | 0.71                | 23.6        |
| West: Erskine St (W)         |      |           |              |      |               |      |           |             |                  |                   |        |           |                |                     |             |
| 10                           | L2   | All MCs   | 87           | 3.6  | 87            | 3.6  | 0.154     | 13.3        | LOS A            | 3.2               | 23.4   | 0.51      | 0.55           | 0.51                | 12.8        |
| 11                           | T1   | All MCs   | 214          | 3.9  | 214           | 3.9  | 0.748     | 16.9        | LOS B            | 10.2              | 73.4   | 0.76      | 0.76           | 0.80                | 8.4         |
| 12                           | R2   | All MCs   | 269          | 2.7  | 269           | 2.7  | *0.748    | 28.1        | LOS B            | 10.2              | 73.4   | 0.87      | 0.85           | 0.92                | 18.7        |
| Approach                     |      |           | 571          | 3.3  | 571           | 3.3  | 0.748     | 21.6        | LOS B            | 10.2              | 73.4   | 0.77      | 0.77           | 0.81                | 15.4        |
| All Vehicles                 |      |           | 1734         | 3.6  | 1734          | 3.6  | 0.748     | 18.3        | LOS B            | 10.2              | 73.4   | 0.63      | 0.63           | 0.64                | 20.4        |

Site Level of Service (LOS) Method: Delay (RTA NSW). Site LOS Method is specified in the Network Data dialog (Override Site Data tab).

Vehicle movement LOS values are based on average delay per movement.

Intersection and Approach LOS values are based on average delay for all vehicle movements.

Delay Model: SIDRA Standard (Control Delay: Geometric Delay is included).

Queue Model: SIDRA queue estimation methods are used for Back of Queue and Queue at Start of Green.

Gap-Acceptance Capacity Formula: SIDRA Standard (Akçelik M3D).

HV (%) values are calculated for All Movement Classes of All Heavy Vehicle Model Designation.

Arrival Flows used in performance calculations are adjusted to include any Initial Queued Demand and Upstream Capacity Constraint effects.

\* Critical Movement (Signal Timing)

| Pedestrian Movement Performance |          |           |             |                  |                       |        |           |                |             |              |             |
|---------------------------------|----------|-----------|-------------|------------------|-----------------------|--------|-----------|----------------|-------------|--------------|-------------|
| Mov ID                          | Crossing | Dem. Flow | Aver. Delay | Level of Service | AVERAGE BACK OF QUEUE |        | Prop. Que | Eff. Stop Rate | Travel Time | Travel Dist. | Aver. Speed |
|                                 |          | ped/h     | sec         |                  | [ Ped                 | Dist ] |           |                | sec         | m            | m/sec       |
|                                 |          |           |             |                  | ped                   | m      |           |                |             |              |             |
| South: Sussex St (S)            |          |           |             |                  |                       |        |           |                |             |              |             |
| P1                              | Full     | 96        | 33.1        | LOS D            | 0.2                   | 0.2    | 0.86      | 0.86           | 49.7        | 20.0         | 0.40        |
| East: Erskine St (E)            |          |           |             |                  |                       |        |           |                |             |              |             |
| P2                              | Full     | 27        | 34.7        | LOS D            | 0.1                   | 0.1    | 0.88      | 0.88           | 51.4        | 20.0         | 0.39        |
| North: Sussex St (N)            |          |           |             |                  |                       |        |           |                |             |              |             |
| P3                              | Full     | 143       | 33.1        | LOS D            | 0.3                   | 0.3    | 0.86      | 0.86           | 49.8        | 20.0         | 0.40        |
| West: Erskine St (W)            |          |           |             |                  |                       |        |           |                |             |              |             |
| P4                              | Full     | 37        | 33.0        | LOS D            | 0.1                   | 0.1    | 0.86      | 0.86           | 49.7        | 20.0         | 0.40        |
| All Pedestrians                 |          | 303       | 33.2        | LOS D            | 0.3                   | 0.3    | 0.86      | 0.86           | 49.9        | 20.0         | 0.40        |

Level of Service (LOS) Method: SIDRA Pedestrian LOS Method (Based on Average Delay)  
 Pedestrian movement LOS values are based on average delay per pedestrian movement.  
 Intersection LOS value for Pedestrians is based on average delay for all pedestrian movements.

# MOVEMENT SUMMARY

Site: BGU13 [BGU13 Kent St / Erskine St (Site Folder: Block 1 - 2023 Weekend Peak)]

Output produced by SIDRA INTERSECTION Version: 9.1.3.210

Network: BGU-N2 [BGU Network 3 (Network Folder: Block 1 Network - 2023 Weekend Peak)]

TCS 307

Site Category: (None)

Signals - EQUISAT (Fixed-Time/SCATS) Coordinated Cycle Time = 90 seconds (Network Site User-Given Phase Times)

| Vehicle Movement Performance |      |           |              |     |               |     |           |             |                  |                   |        |           |                |                     |             |
|------------------------------|------|-----------|--------------|-----|---------------|-----|-----------|-------------|------------------|-------------------|--------|-----------|----------------|---------------------|-------------|
| Mov ID                       | Turn | Mov Class | Demand Flows |     | Arrival Flows |     | Deg. Satn | Aver. Delay | Level of Service | 95% Back Of Queue |        | Prop. Que | Eff. Stop Rate | Aver. No. of Cycles | Aver. Speed |
|                              |      |           | [ Total HV ] | %   | [ Total HV ]  | %   |           |             |                  | [ Veh. veh        | Dist ] |           |                |                     |             |
|                              |      |           | veh/h        | %   | veh/h         | %   | v/c       | sec         |                  | m                 |        |           |                |                     | km/h        |
| South: Kent St (S)           |      |           |              |     |               |     |           |             |                  |                   |        |           |                |                     |             |
| 1                            | L2   | All MCs   | 93           | 0.0 | 93            | 0.0 | 0.121     | 20.9        | LOS B            | 2.5               | 17.5   | 0.65      | 0.68           | 0.65                | 19.2        |
| 2                            | T1   | All MCs   | 309          | 2.4 | 309           | 2.4 | *0.192    | 17.8        | LOS B            | 4.2               | 29.9   | 0.67      | 0.55           | 0.67                | 20.8        |
| 3                            | R2   | All MCs   | 1            | 0.0 | 1             | 0.0 | 0.004     | 10.2        | LOS A            | 0.2               | 0.5    | 0.43      | 0.31           | 0.43                | 23.5        |
| Approach                     |      |           | 403          | 1.8 | 403           | 1.8 | 0.192     | 18.5        | LOS B            | 4.2               | 29.9   | 0.66      | 0.58           | 0.66                | 20.4        |
| East: Erskine St (E)         |      |           |              |     |               |     |           |             |                  |                   |        |           |                |                     |             |
| 5                            | T1   | All MCs   | 309          | 2.7 | 309           | 2.7 | 0.489     | 44.6        | LOS D            | 6.0               | 42.7   | 0.88      | 0.72           | 0.88                | 6.2         |
| 6                            | R2   | All MCs   | 8            | 0.0 | 8             | 0.0 | *0.489    | 52.4        | LOS D            | 5.8               | 41.7   | 0.88      | 0.72           | 0.88                | 6.2         |
| Approach                     |      |           | 318          | 2.6 | 318           | 2.6 | 0.489     | 44.8        | LOS D            | 6.0               | 42.7   | 0.88      | 0.72           | 0.88                | 6.2         |
| North: Kent St (N)           |      |           |              |     |               |     |           |             |                  |                   |        |           |                |                     |             |
| 7                            | L2   | All MCs   | 5            | 0.0 | 5             | 0.0 | 0.006     | 10.0        | LOS A            | 0.4               | 1.0    | 0.43      | 0.34           | 0.43                | 19.6        |
| 8                            | T1   | All MCs   | 17           | 0.0 | 17            | 0.0 | 0.006     | 7.8         | LOS A            | 0.4               | 1.0    | 0.43      | 0.34           | 0.43                | 24.3        |
| 9                            | R2   | All MCs   | 138          | 2.3 | 138           | 2.3 | *0.715    | 48.9        | LOS D            | 6.4               | 45.5   | 1.00      | 0.89           | 1.14                | 6.2         |
| Approach                     |      |           | 160          | 2.0 | 160           | 2.0 | 0.715     | 43.3        | LOS D            | 6.4               | 45.5   | 0.92      | 0.82           | 1.04                | 7.9         |
| West: Erskine St (W)         |      |           |              |     |               |     |           |             |                  |                   |        |           |                |                     |             |
| 10                           | L2   | All MCs   | 68           | 3.1 | 68            | 3.1 | 0.137     | 28.1        | LOS B            | 1.7               | 12.3   | 0.59      | 0.65           | 0.59                | 9.7         |
| 11                           | T1   | All MCs   | 165          | 8.3 | 165           | 8.3 | 0.367     | 26.8        | LOS B            | 4.8               | 35.9   | 0.69      | 0.57           | 0.69                | 13.9        |
| Approach                     |      |           | 234          | 6.8 | 234           | 6.8 | 0.367     | 27.1        | LOS B            | 4.8               | 35.9   | 0.66      | 0.59           | 0.66                | 12.7        |
| All Vehicles                 |      |           | 1115         | 3.1 | 1115          | 3.1 | 0.715     | 31.4        | LOS C            | 6.4               | 45.5   | 0.76      | 0.66           | 0.78                | 12.8        |

Site Level of Service (LOS) Method: Delay (RTA NSW). Site LOS Method is specified in the Network Data dialog (Override Site Data tab).

Vehicle movement LOS values are based on average delay per movement.

Intersection and Approach LOS values are based on average delay for all vehicle movements.

Delay Model: SIDRA Standard (Control Delay: Geometric Delay is included).

Queue Model: SIDRA queue estimation methods are used for Back of Queue and Queue at Start of Green.

Gap-Acceptance Capacity Formula: SIDRA Standard (Akçelik M3D).

HV (%) values are calculated for All Movement Classes of All Heavy Vehicle Model Designation.

Arrival Flows used in performance calculations are adjusted to include any Initial Queued Demand and Upstream Capacity Constraint effects.

\* Critical Movement (Signal Timing)

| Pedestrian Movement Performance |          |           |             |                  |                       |        |           |                |             |              |             |
|---------------------------------|----------|-----------|-------------|------------------|-----------------------|--------|-----------|----------------|-------------|--------------|-------------|
| Mov ID                          | Crossing | Dem. Flow | Aver. Delay | Level of Service | AVERAGE BACK OF QUEUE |        | Prop. Que | Eff. Stop Rate | Travel Time | Travel Dist. | Aver. Speed |
|                                 |          | ped/h     | sec         |                  | [ Ped                 | Dist ] |           |                | sec         | m            | m/sec       |
|                                 |          |           |             |                  | ped                   | m      |           |                |             |              |             |
| South: Kent St (S)              |          |           |             |                  |                       |        |           |                |             |              |             |
| P1                              | Full     | 148       | 35.8        | LOS D            | 0.3                   | 0.3    | 0.89      | 0.89           | 52.4        | 20.0         | 0.38        |
| East: Erskine St (E)            |          |           |             |                  |                       |        |           |                |             |              |             |
| P2                              | Full     | 80        | 36.6        | LOS D            | 0.2                   | 0.2    | 0.90      | 0.90           | 53.2        | 20.0         | 0.38        |
| North: Kent St (N)              |          |           |             |                  |                       |        |           |                |             |              |             |
| P3                              | Full     | 106       | 35.7        | LOS D            | 0.2                   | 0.2    | 0.89      | 0.89           | 52.4        | 20.0         | 0.38        |
| West: Erskine St (W)            |          |           |             |                  |                       |        |           |                |             |              |             |
| P4                              | Full     | 58        | 35.6        | LOS D            | 0.1                   | 0.1    | 0.89      | 0.89           | 52.3        | 20.0         | 0.38        |
| All Pedestrians                 |          | 393       | 35.9        | LOS D            | 0.3                   | 0.3    | 0.90      | 0.90           | 52.6        | 20.0         | 0.38        |

Level of Service (LOS) Method: SIDRA Pedestrian LOS Method (Based on Average Delay)

Pedestrian movement LOS values are based on average delay per pedestrian movement.

Intersection LOS value for Pedestrians is based on average delay for all pedestrian movements.

**SIDRA INTERSECTION 9.1 | Copyright © 2000-2022 Akcelik and Associates Pty Ltd | sidrasolutions.com**

Organisation: AECOM AUSTRALIA PTY LTD | Licence: NETWORK / Enterprise Level 1 | Processed: Monday, 17 July 2023 11:23:58 AM

Project: C:\Users\YeungMA\AECOM\ANZ-NAC-Sydney Metro-Sydney Metro C&SW Operational Monitoring - General\400\_Technical\432\_Traffic Analysis\SIDRA Modelling\01 Models (Geometry Only)\Block 1\Rev1\_Review\04 SM C&SW\_BGU (Block 1)\_PS.sip9

# MOVEMENT SUMMARY

Site: BGU14 [BGU14 Sussex St / King St (Site Folder: Block 1 - 2023 Weekend Peak)]

Output produced by SIDRA INTERSECTION Version: 9.1.1.200

Network: BGU-N2 [BGU Network 4 (Network Folder: Block 1 Network - 2023 Weekend Peak)]

TCS 284

Site Category: (None)

Signals - EQUISAT (Fixed-Time/SCATS) Coordinated Cycle Time = 90 seconds (Network Site User-Given Phase Times)

| Vehicle Movement Performance |      |           |              |      |               |      |           |             |                  |                   |          |           |                |                     |             |
|------------------------------|------|-----------|--------------|------|---------------|------|-----------|-------------|------------------|-------------------|----------|-----------|----------------|---------------------|-------------|
| Mov ID                       | Turn | Mov Class | Demand Flows |      | Arrival Flows |      | Deg. Satn | Aver. Delay | Level of Service | 95% Back Of Queue |          | Prop. Que | Eff. Stop Rate | Aver. No. of Cycles | Aver. Speed |
|                              |      |           | [ Total HV ] | %    | [ Total HV ]  | %    |           |             |                  | [ Veh. veh        | Dist ] m |           |                |                     |             |
| East: King St (E)            |      |           |              |      |               |      |           |             |                  |                   |          |           |                |                     |             |
| 4a                           | L1   | All MCs   | 18           | 0.0  | 18            | 0.0  | 0.025     | 41.9        | LOS C            | 0.8               | 2.0      | 1.00      | 0.68           | 1.00                | 18.8        |
| Approach                     |      |           | 18           | 0.0  | 18            | 0.0  | 0.025     | 41.9        | LOS C            | 0.8               | 2.0      | 1.00      | 0.68           | 1.00                | 18.8        |
| North: Sussex St (N)         |      |           |              |      |               |      |           |             |                  |                   |          |           |                |                     |             |
| 7                            | L2   | All MCs   | 98           | 10.8 | 98            | 10.8 | 0.492     | 22.4        | LOS B            | 12.8              | 92.5     | 0.73      | 0.67           | 0.73                | 20.6        |
| 8                            | T1   | All MCs   | 781          | 1.6  | 781           | 1.6  | 0.492     | 17.0        | LOS B            | 13.5              | 95.6     | 0.73      | 0.65           | 0.73                | 27.7        |
| Approach                     |      |           | 879          | 2.6  | 879           | 2.6  | 0.492     | 17.6        | LOS B            | 13.5              | 95.6     | 0.73      | 0.66           | 0.73                | 27.1        |
| SouthWest: King St (SW)      |      |           |              |      |               |      |           |             |                  |                   |          |           |                |                     |             |
| 30a                          | L1   | All MCs   | 325          | 3.9  | 325           | 3.9  | *0.420    | 14.1        | LOS A            | 6.0               | 43.1     | 0.75      | 0.76           | 0.75                | 36.7        |
| 32a                          | R1   | All MCs   | 859          | 0.9  | 859           | 0.9  | *0.568    | 27.0        | LOS B            | 14.5              | 102.0    | 0.84      | 0.80           | 0.84                | 28.7        |
| 32b                          | R3   | All MCs   | 173          | 8.5  | 173           | 8.5  | 0.296     | 25.8        | LOS B            | 5.3               | 39.6     | 0.73      | 0.77           | 0.73                | 31.4        |
| Approach                     |      |           | 1357         | 2.6  | 1357          | 2.6  | 0.568     | 23.7        | LOS B            | 14.5              | 102.0    | 0.80      | 0.78           | 0.80                | 31.0        |
| All Vehicles                 |      |           | 2254         | 2.6  | 2254          | 2.6  | 0.568     | 21.5        | LOS B            | 14.5              | 102.0    | 0.78      | 0.73           | 0.78                | 29.6        |

Site Level of Service (LOS) Method: Delay (RTA NSW). Site LOS Method is specified in the Network Data dialog (Override Site Data tab).

Vehicle movement LOS values are based on average delay per movement.

Intersection and Approach LOS values are based on average delay for all vehicle movements.

Delay Model: SIDRA Standard (Control Delay: Geometric Delay is included).

Queue Model: SIDRA queue estimation methods are used for Back of Queue and Queue at Start of Green.

Gap-Acceptance Capacity Formula: SIDRA Standard (Akçelik M3D).

HV (%) values are calculated for All Movement Classes of All Heavy Vehicle Model Designation.

Arrival Flows used in performance calculations are adjusted to include any Initial Queued Demand and Upstream Capacity Constraint effects.

\* Critical Movement (Signal Timing)



| Pedestrian Movement Performance |                 |                    |                    |                  |                       |             |           |                |                    |                   |                      |
|---------------------------------|-----------------|--------------------|--------------------|------------------|-----------------------|-------------|-----------|----------------|--------------------|-------------------|----------------------|
| Mov ID                          | Crossing        | Dem. Flow<br>ped/h | Aver. Delay<br>sec | Level of Service | AVERAGE BACK OF QUEUE |             | Prop. Que | Eff. Stop Rate | Travel Time<br>sec | Travel Dist.<br>m | Aver. Speed<br>m/sec |
|                                 |                 |                    |                    |                  | [ Ped<br>ped          | Dist ]<br>m |           |                |                    |                   |                      |
| South: Sussex St (S)            |                 |                    |                    |                  |                       |             |           |                |                    |                   |                      |
| P1                              | Full            | 129                | 40.4               | LOS E            | 0.3                   | 0.3         | 0.95      | 0.95           | 57.0               | 20.0              | 0.35                 |
| East: King St (E)               |                 |                    |                    |                  |                       |             |           |                |                    |                   |                      |
| P2                              | Full            | 143                | 36.7               | LOS D            | 0.3                   | 0.3         | 0.91      | 0.91           | 53.3               | 20.0              | 0.37                 |
| North: Sussex St (N)            |                 |                    |                    |                  |                       |             |           |                |                    |                   |                      |
| P3                              | Full            | 152                | 35.8               | LOS D            | 0.3                   | 0.3         | 0.89      | 0.89           | 52.4               | 20.0              | 0.38                 |
| SouthWest: King St (SW)         |                 |                    |                    |                  |                       |             |           |                |                    |                   |                      |
| P8                              | Full            | 100                | 37.5               | LOS D            | 0.2                   | 0.2         | 0.91      | 0.91           | 204.2              | 200.0             | 0.98                 |
| P8B                             | Slip/<br>Bypass | 38                 | 40.2               | LOS E            | 0.1                   | 0.1         | 0.95      | 0.95           | 206.9              | 200.0             | 0.97                 |
| All Pedestrians                 |                 | 562                | 37.7               | LOS D            | 0.3                   | 0.3         | 0.92      | 0.92           | 91.1               | 64.2              | 0.70                 |

Level of Service (LOS) Method: SIDRA Pedestrian LOS Method (Based on Average Delay)  
Pedestrian movement LOS values are based on average delay per pedestrian movement.  
Intersection LOS value for Pedestrians is based on average delay for all pedestrian movements.

# MOVEMENT SUMMARY

Site: BGU15 [BGU15 Kent St / King St (Site Folder: Block 1 - 2023 Weekend Peak)]

Output produced by SIDRA INTERSECTION Version: 9.1.1.200

Network: BGU-N2 [BGU Network 4 (Network Folder: Block 1 Network - 2023 Weekend Peak)]

TCS 283

Site Category: NA

Signals - EQUISAT (Fixed-Time/SCATS) Coordinated Cycle Time = 90 seconds (Network Site User-Given Phase Times)

| Vehicle Movement Performance |      |           |              |     |               |     |           |             |                  |                   |        |           |                |                     |             |
|------------------------------|------|-----------|--------------|-----|---------------|-----|-----------|-------------|------------------|-------------------|--------|-----------|----------------|---------------------|-------------|
| Mov ID                       | Turn | Mov Class | Demand Flows |     | Arrival Flows |     | Deg. Satn | Aver. Delay | Level of Service | 95% Back Of Queue |        | Prop. Que | Eff. Stop Rate | Aver. No. of Cycles | Aver. Speed |
|                              |      |           | [ Total HV ] | %   | [ Total HV ]  | %   |           |             |                  | [ Veh. veh        | Dist ] |           |                |                     |             |
|                              |      |           | veh/h        | %   | veh/h         | %   | v/c       | sec         |                  | m                 |        |           |                |                     | km/h        |
| South: Kent St (S)           |      |           |              |     |               |     |           |             |                  |                   |        |           |                |                     |             |
| 1                            | L2   | All MCs   | 2            | 0.0 | 2             | 0.0 | 0.013     | 40.8        | LOS C            | 0.4               | 1.0    | 0.91      | 0.60           | 0.91                | 14.2        |
| 2                            | T1   | All MCs   | 266          | 2.0 | 266           | 2.0 | *0.376    | 26.9        | LOS B            | 7.5               | 53.7   | 0.82      | 0.67           | 0.82                | 23.7        |
| 3                            | R2   | All MCs   | 143          | 0.0 | 143           | 0.0 | 0.281     | 32.3        | LOS C            | 4.9               | 34.2   | 0.84      | 0.75           | 0.84                | 16.6        |
| Approach                     |      |           | 412          | 1.3 | 412           | 1.3 | 0.376     | 28.8        | LOS C            | 7.5               | 53.7   | 0.83      | 0.70           | 0.83                | 21.4        |
| East: King St (E)            |      |           |              |     |               |     |           |             |                  |                   |        |           |                |                     |             |
| 5                            | T1   | All MCs   | 11           | 0.0 | 11            | 0.0 | 0.023     | 38.2        | LOS C            | 0.5               | 1.2    | 0.93      | 0.61           | 0.93                | 5.1         |
| 6                            | R2   | All MCs   | 1            | 0.0 | 1             | 0.0 | 0.023     | 47.2        | LOS D            | 0.5               | 1.2    | 0.93      | 0.61           | 0.93                | 14.9        |
| Approach                     |      |           | 12           | 0.0 | 12            | 0.0 | 0.023     | 39.0        | LOS C            | 0.5               | 1.2    | 0.93      | 0.61           | 0.93                | 6.3         |
| North: Kent St (N)           |      |           |              |     |               |     |           |             |                  |                   |        |           |                |                     |             |
| 7                            | L2   | All MCs   | 4            | 0.0 | 4             | 0.0 | 0.016     | 40.8        | LOS C            | 0.4               | 1.2    | 0.91      | 0.61           | 0.91                | 11.3        |
| 8                            | T1   | All MCs   | 7            | 0.0 | 7             | 0.0 | *0.016    | 37.4        | LOS C            | 0.4               | 1.2    | 0.91      | 0.61           | 0.91                | 20.1        |
| 9                            | R2   | All MCs   | 5            | 0.0 | 5             | 0.0 | 0.017     | 41.5        | LOS C            | 0.2               | 0.6    | 0.91      | 0.63           | 0.91                | 13.1        |
| Approach                     |      |           | 17           | 0.0 | 17            | 0.0 | 0.017     | 39.6        | LOS C            | 0.4               | 1.2    | 0.91      | 0.62           | 0.91                | 15.8        |
| West: King St (W)            |      |           |              |     |               |     |           |             |                  |                   |        |           |                |                     |             |
| 10                           | L2   | All MCs   | 147          | 0.0 | 147           | 0.0 | *0.497    | 44.3        | LOS D            | 7.9               | 55.4   | 0.96      | 0.80           | 0.96                | 15.6        |
| 11                           | T1   | All MCs   | 801          | 2.5 | 801           | 2.5 | *0.497    | 9.5         | LOS A            | 7.9               | 55.4   | 0.45      | 0.38           | 0.45                | 21.4        |
| Approach                     |      |           | 948          | 2.1 | 948           | 2.1 | 0.497     | 14.9        | LOS B            | 7.9               | 55.4   | 0.53      | 0.45           | 0.53                | 19.4        |
| All Vehicles                 |      |           | 1388         | 1.8 | 1388          | 1.8 | 0.497     | 19.5        | LOS B            | 7.9               | 55.4   | 0.63      | 0.53           | 0.63                | 20.1        |

Site Level of Service (LOS) Method: Delay (RTA NSW). Site LOS Method is specified in the Network Data dialog (Override Site Data tab).

Vehicle movement LOS values are based on average delay per movement.

Intersection and Approach LOS values are based on average delay for all vehicle movements.

Delay Model: SIDRA Standard (Control Delay: Geometric Delay is included).

Queue Model: SIDRA queue estimation methods are used for Back of Queue and Queue at Start of Green.

Gap-Acceptance Capacity Formula: SIDRA Standard (Akçelik M3D).

HV (%) values are calculated for All Movement Classes of All Heavy Vehicle Model Designation.

Arrival Flows used in performance calculations are adjusted to include any Initial Queued Demand and Upstream Capacity Constraint effects.

\* Critical Movement (Signal Timing)

| Pedestrian Movement Performance |          |           |             |                  |                       |        |           |                |             |              |             |
|---------------------------------|----------|-----------|-------------|------------------|-----------------------|--------|-----------|----------------|-------------|--------------|-------------|
| Mov ID                          | Crossing | Dem. Flow | Aver. Delay | Level of Service | AVERAGE BACK OF QUEUE |        | Prop. Que | Eff. Stop Rate | Travel Time | Travel Dist. | Aver. Speed |
|                                 |          | ped/h     | sec         |                  | [ Ped                 | Dist ] |           |                | sec         | m            | m/sec       |
|                                 |          |           |             |                  | ped                   | m      |           |                |             |              |             |
| South: Kent St (S)              |          |           |             |                  |                       |        |           |                |             |              |             |
| P1                              | Full     | 127       | 36.6        | LOS D            | 0.3                   | 0.3    | 0.90      | 0.90           | 53.3        | 20.0         | 0.38        |
| East: King St (E)               |          |           |             |                  |                       |        |           |                |             |              |             |
| P2                              | Full     | 173       | 37.6        | LOS D            | 0.4                   | 0.4    | 0.92      | 0.92           | 54.3        | 20.0         | 0.37        |
| North: Kent St (N)              |          |           |             |                  |                       |        |           |                |             |              |             |
| P3                              | Full     | 118       | 37.5        | LOS D            | 0.3                   | 0.3    | 0.92      | 0.92           | 54.2        | 20.0         | 0.37        |
| West: King St (W)               |          |           |             |                  |                       |        |           |                |             |              |             |
| P4                              | Full     | 93        | 37.5        | LOS D            | 0.2                   | 0.2    | 0.91      | 0.91           | 54.2        | 20.0         | 0.37        |
| All Pedestrians                 |          | 511       | 37.3        | LOS D            | 0.4                   | 0.4    | 0.91      | 0.91           | 54.0        | 20.0         | 0.37        |

Level of Service (LOS) Method: SIDRA Pedestrian LOS Method (Based on Average Delay)

Pedestrian movement LOS values are based on average delay per pedestrian movement.

Intersection LOS value for Pedestrians is based on average delay for all pedestrian movements.

**SIDRA INTERSECTION 9.1 | Copyright © 2000-2022 Akcelik and Associates Pty Ltd | sidrasolutions.com**

Organisation: AECOM AUSTRALIA PTY LTD | Licence: NETWORK / Enterprise Level 1 | Processed: Friday, 14 July 2023 3:11:39 PM

Project: C:\Users\YeungMA\AECOM\ANZ-NAC-Sydney Metro-Sydney Metro C&SW Operational Monitoring - General\400\_Technical\432\_Traffic Analysis\SIDRA Modelling\01 Models (Geometry Only)\Block 1\Rev1\_Review\04 SM C&SW\_BGU (Block 1)\_PS.sip9

# MOVEMENT SUMMARY

Site: BGU18 [BGU18 Shelley St / Erskine St (Site Folder: Block 1 - 2023 Weekend Peak)]

Output produced by SIDRA INTERSECTION Version: 9.1.3.210

Network: BGU-N2 [BGU Network 3 (Network Folder: Block 1 Network - 2023 Weekend Peak)]

TCS 305

Site Category: (None)

Signals - EQUISAT (Fixed-Time/SCATS) Isolated Cycle Time = 45 seconds (Site User-Given Phase Times)

| Vehicle Movement Performance |      |           |                       |      |                       |      |           |             |                  |                   |               |           |                |                     |                  |
|------------------------------|------|-----------|-----------------------|------|-----------------------|------|-----------|-------------|------------------|-------------------|---------------|-----------|----------------|---------------------|------------------|
| Mov ID                       | Turn | Mov Class | Demand Flows          |      | Arrival Flows         |      | Deg. Satn | Aver. Delay | Level of Service | 95% Back Of Queue |               | Prop. Que | Eff. Stop Rate | Aver. No. of Cycles | Aver. Speed km/h |
|                              |      |           | [ Total HV ]<br>veh/h | %    | [ Total HV ]<br>veh/h | %    |           |             |                  | [ Veh. veh        | [ Dist ]<br>m |           |                |                     |                  |
| South: Shelley St (S)        |      |           |                       |      |                       |      |           |             |                  |                   |               |           |                |                     |                  |
| 1                            | L2   | All MCs   | 33                    | 6.5  | 33                    | 6.5  | 0.145     | 14.6        | LOS B            | 1.5               | 10.4          | 0.69      | 0.59           | 0.69                | 17.6             |
| 2                            | T1   | All MCs   | 66                    | 0.0  | 66                    | 0.0  | 0.145     | 9.7         | LOS A            | 1.5               | 10.4          | 0.69      | 0.59           | 0.69                | 24.2             |
| 3                            | R2   | All MCs   | 232                   | 3.2  | 232                   | 3.2  | *0.975    | 60.3        | LOS E            | 10.2              | 73.6          | 1.00      | 1.62           | 2.40                | 5.8              |
| Approach                     |      |           | 331                   | 2.9  | 331                   | 2.9  | 0.975     | 45.7        | LOS D            | 10.2              | 73.6          | 0.91      | 1.31           | 1.89                | 8.3              |
| East: Erskine St (E)         |      |           |                       |      |                       |      |           |             |                  |                   |               |           |                |                     |                  |
| 4                            | L2   | All MCs   | 76                    | 5.6  | 76                    | 5.6  | 0.162     | 17.6        | LOS B            | 1.3               | 9.7           | 0.80      | 0.71           | 0.80                | 17.5             |
| 5                            | T1   | All MCs   | 116                   | 0.9  | 116                   | 0.9  | 0.228     | 10.9        | LOS A            | 2.2               | 15.5          | 0.74      | 0.61           | 0.74                | 18.3             |
| 6                            | R2   | All MCs   | 22                    | 0.0  | 22                    | 0.0  | 0.228     | 16.7        | LOS B            | 2.2               | 15.5          | 0.74      | 0.61           | 0.74                | 19.5             |
| Approach                     |      |           | 214                   | 2.5  | 214                   | 2.5  | 0.228     | 13.9        | LOS A            | 2.2               | 15.5          | 0.76      | 0.65           | 0.76                | 18.0             |
| North: Shelley St (N)        |      |           |                       |      |                       |      |           |             |                  |                   |               |           |                |                     |                  |
| 7                            | L2   | All MCs   | 140                   | 2.3  | 140                   | 2.3  | 0.204     | 13.9        | LOS A            | 2.1               | 15.2          | 0.71      | 0.70           | 0.71                | 14.8             |
| 8                            | T1   | All MCs   | 22                    | 0.0  | 22                    | 0.0  | 0.055     | 9.5         | LOS A            | 0.5               | 3.4           | 0.66      | 0.55           | 0.66                | 24.4             |
| 9                            | R2   | All MCs   | 12                    | 0.0  | 12                    | 0.0  | 0.055     | 13.6        | LOS A            | 0.5               | 3.4           | 0.66      | 0.55           | 0.66                | 15.1             |
| Approach                     |      |           | 174                   | 1.8  | 174                   | 1.8  | 0.204     | 13.3        | LOS A            | 2.1               | 15.2          | 0.70      | 0.67           | 0.70                | 16.3             |
| West: Erskine St (W)         |      |           |                       |      |                       |      |           |             |                  |                   |               |           |                |                     |                  |
| 10                           | L2   | All MCs   | 18                    | 0.0  | 18                    | 0.0  | 0.251     | 17.0        | LOS B            | 2.6               | 18.8          | 0.75      | 0.62           | 0.75                | 19.9             |
| 11                           | T1   | All MCs   | 199                   | 4.2  | 199                   | 4.2  | *0.251    | 11.4        | LOS A            | 2.6               | 18.8          | 0.76      | 0.63           | 0.76                | 13.0             |
| 12                           | R2   | All MCs   | 20                    | 10.5 | 20                    | 10.5 | 0.251     | 20.2        | LOS B            | 1.3               | 9.7           | 0.78      | 0.65           | 0.78                | 19.7             |
| Approach                     |      |           | 237                   | 4.4  | 237                   | 4.4  | 0.251     | 12.6        | LOS A            | 2.6               | 18.8          | 0.76      | 0.63           | 0.76                | 14.5             |
| All Vehicles                 |      |           | 955                   | 3.0  | 955                   | 3.0  | 0.975     | 24.5        | LOS B            | 10.2              | 73.6          | 0.80      | 0.88           | 1.14                | 11.7             |

Site Level of Service (LOS) Method: Delay (RTA NSW). Site LOS Method is specified in the Network Data dialog (Override Site Data tab).

Vehicle movement LOS values are based on average delay per movement.

Intersection and Approach LOS values are based on average delay for all vehicle movements.

Delay Model: SIDRA Standard (Control Delay: Geometric Delay is included).

Queue Model: SIDRA queue estimation methods are used for Back of Queue and Queue at Start of Green.

Gap-Acceptance Capacity Formula: SIDRA Standard (Akçelik M3D).

HV (%) values are calculated for All Movement Classes of All Heavy Vehicle Model Designation.

Arrival Flows used in performance calculations are adjusted to include any Initial Queued Demand and Upstream Capacity Constraint effects.

\* Critical Movement (Signal Timing)

| Pedestrian Movement Performance |          |           |             |                  |                       |        |           |                |             |              |             |
|---------------------------------|----------|-----------|-------------|------------------|-----------------------|--------|-----------|----------------|-------------|--------------|-------------|
| Mov ID                          | Crossing | Dem. Flow | Aver. Delay | Level of Service | AVERAGE BACK OF QUEUE |        | Prop. Que | Eff. Stop Rate | Travel Time | Travel Dist. | Aver. Speed |
|                                 |          | ped/h     | sec         |                  | [ Ped                 | Dist ] |           |                | sec         | m            | m/sec       |
|                                 |          |           |             |                  | ped                   | m      |           |                |             |              |             |
| South: Shelley St (S)           |          |           |             |                  |                       |        |           |                |             |              |             |
| P1                              | Full     | 191       | 11.5        | LOS B            | 0.2                   | 0.2    | 0.72      | 0.72           | 178.1       | 200.0        | 1.12        |
| East: Erskine St (E)            |          |           |             |                  |                       |        |           |                |             |              |             |
| P2                              | Full     | 12        | 11.4        | LOS B            | 0.0                   | 0.0    | 0.71      | 0.71           | 178.0       | 200.0        | 1.12        |
| North: Shelley St (N)           |          |           |             |                  |                       |        |           |                |             |              |             |
| P3                              | Full     | 117       | 11.4        | LOS B            | 0.1                   | 0.1    | 0.71      | 0.71           | 178.1       | 200.0        | 1.12        |
| West: Erskine St (W)            |          |           |             |                  |                       |        |           |                |             |              |             |
| P4                              | Full     | 71        | 11.4        | LOS B            | 0.1                   | 0.1    | 0.71      | 0.71           | 178.1       | 200.0        | 1.12        |
| All Pedestrians                 |          | 389       | 11.4        | LOS B            | 0.2                   | 0.2    | 0.72      | 0.72           | 178.1       | 200.0        | 1.12        |

Level of Service (LOS) Method: SIDRA Pedestrian LOS Method (Based on Average Delay)

Pedestrian movement LOS values are based on average delay per pedestrian movement.

Intersection LOS value for Pedestrians is based on average delay for all pedestrian movements.

**SIDRA INTERSECTION 9.1 | Copyright © 2000-2022 Akcelik and Associates Pty Ltd | sidrasolutions.com**

Organisation: AECOM AUSTRALIA PTY LTD | Licence: NETWORK / Enterprise Level 1 | Processed: Monday, 17 July 2023 11:23:58 AM

Project: C:\Users\YeungMA\AECOM\ANZ-NAC-Sydney Metro-Sydney Metro C&SW Operational Monitoring - General\400\_Technical\432\_Traffic Analysis\SIDRA Modelling\01 Models (Geometry Only)\Block 1\Rev1\_Review\04 SM C&SW\_BGU (Block 1)\_PS.sip9

# MOVEMENT SUMMARY

Site: MPL01 [MPL01 Hunter St / Castlereagh St / Bligh St (Site Folder: Block 1 Model - 2023 AM Peak)]

Output produced by SIDRA INTERSECTION Version: 9.1.1.200

Network: MPL-N1 [MPL Network 1 (Network Folder: Block 1 Network - 2023 AM Peak)]

TCS 244

Site Category: (None)

Signals - EQUISAT (Fixed-Time/SCATS) Coordinated Cycle Time = 90 seconds (Network Site User-Given Phase Times)

| Vehicle Movement Performance |      |           |              |              |               |            |           |             |                  |                   |      |           |                |                     |             |
|------------------------------|------|-----------|--------------|--------------|---------------|------------|-----------|-------------|------------------|-------------------|------|-----------|----------------|---------------------|-------------|
| Mov ID                       | Turn | Mov Class | Demand Flows |              | Arrival Flows |            | Deg. Satn | Aver. Delay | Level of Service | 95% Back Of Queue |      | Prop. Que | Eff. Stop Rate | Aver. No. of Cycles | Aver. Speed |
|                              |      |           | [ Total HV ] | [ Total HV ] | [ Veh. veh ]  | [ Dist ] m |           |             |                  |                   |      |           |                |                     |             |
|                              |      |           | veh/h        | %            | veh/h         | %          | v/c       | sec         |                  |                   |      |           |                |                     | km/h        |
| East: Hunter St (E)          |      |           |              |              |               |            |           |             |                  |                   |      |           |                |                     |             |
| 4                            | L2   | All MCs   | 249          | 20.3         | 249           | 20.3       | *0.421    | 25.1        | LOS B            | 7.9               | 65.3 | 0.78      | 0.76           | 0.78                | 15.8        |
| 6a                           | R1   | All MCs   | 326          | 4.8          | 326           | 4.8        | 0.394     | 16.5        | LOS B            | 8.5               | 61.9 | 0.63      | 0.65           | 0.63                | 18.7        |
| Approach                     |      |           | 576          | 11.5         | 576           | 11.5       | 0.421     | 20.2        | LOS B            | 8.5               | 65.3 | 0.70      | 0.70           | 0.70                | 17.2        |
| North: Bligh St (N)          |      |           |              |              |               |            |           |             |                  |                   |      |           |                |                     |             |
| 7                            | L2   | All MCs   | 96           | 34.1         | 96            | 34.1       | *0.421    | 45.0        | LOS D            | 3.6               | 26.9 | 0.85      | 0.74           | 0.85                | 12.9        |
| 8                            | T1   | All MCs   | 82           | 15.4         | 82            | 15.4       | 0.106     | 31.3        | LOS C            | 1.5               | 9.1  | 0.76      | 0.58           | 0.76                | 20.9        |
| 9b                           | R3   | All MCs   | 6            | 50.0         | 6             | 50.0       | 0.106     | 36.2        | LOS C            | 1.3               | 8.8  | 0.76      | 0.59           | 0.76                | 18.9        |
| Approach                     |      |           | 184          | 26.3         | 184           | 26.3       | 0.421     | 38.6        | LOS C            | 3.6               | 26.9 | 0.81      | 0.67           | 0.81                | 16.8        |
| NorthWest: Hunter St (NW)    |      |           |              |              |               |            |           |             |                  |                   |      |           |                |                     |             |
| 27a                          | L1   | All MCs   | 252          | 10.9         | 252           | 10.9       | 0.288     | 13.3        | LOS A            | 4.1               | 31.2 | 0.58      | 0.64           | 0.58                | 18.0        |
| 29a                          | R1   | All MCs   | 86           | 8.5          | 86            | 8.5        | *0.288    | 16.2        | LOS B            | 4.1               | 31.2 | 0.67      | 0.68           | 0.67                | 23.9        |
| Approach                     |      |           | 338          | 10.3         | 338           | 10.3       | 0.288     | 14.1        | LOS A            | 4.1               | 31.2 | 0.60      | 0.65           | 0.60                | 20.1        |
| All Vehicles                 |      |           | 1098         | 13.6         | 1098          | 13.6       | 0.421     | 21.4        | LOS B            | 8.5               | 65.3 | 0.69      | 0.68           | 0.69                | 17.8        |

Site Level of Service (LOS) Method: Delay (RTA NSW). Site LOS Method is specified in the Network Data dialog (Override Site Data tab).

Vehicle movement LOS values are based on average delay per movement.

Intersection and Approach LOS values are based on average delay for all vehicle movements.

Delay Model: SIDRA Standard (Control Delay: Geometric Delay is included).

Queue Model: SIDRA queue estimation methods are used for Back of Queue and Queue at Start of Green.

Gap-Acceptance Capacity Formula: SIDRA Standard (Akçelik M3D).

HV (%) values are calculated for All Movement Classes of All Heavy Vehicle Model Designation.

Arrival Flows used in performance calculations are adjusted to include any Initial Queued Demand and Upstream Capacity Constraint effects.

\* Critical Movement (Signal Timing)

| Pedestrian Movement Performance |          |           |             |                  |                       |        |           |                |             |              |             |
|---------------------------------|----------|-----------|-------------|------------------|-----------------------|--------|-----------|----------------|-------------|--------------|-------------|
| Mov ID                          | Crossing | Dem. Flow | Aver. Delay | Level of Service | AVERAGE BACK OF QUEUE |        | Prop. Que | Eff. Stop Rate | Travel Time | Travel Dist. | Aver. Speed |
|                                 |          | ped/h     | sec         |                  | [ Ped                 | Dist ] |           |                | sec         | m            | m/sec       |
|                                 |          |           |             |                  | ped                   | m      |           |                |             |              |             |
| South: Castlereagh St (S)       |          |           |             |                  |                       |        |           |                |             |              |             |
| P1                              | Full     | 571       | 39.2        | LOS D            | 1.4                   | 1.4    | 0.94      | 0.94           | 205.9       | 200.0        | 0.97        |
| East: Hunter St (E)             |          |           |             |                  |                       |        |           |                |             |              |             |
| P2                              | Full     | 256       | 35.0        | LOS D            | 0.6                   | 0.6    | 0.89      | 0.89           | 201.7       | 200.0        | 0.99        |
| North: Bligh St (N)             |          |           |             |                  |                       |        |           |                |             |              |             |
| P3                              | Full     | 618       | 39.3        | LOS D            | 1.5                   | 1.5    | 0.95      | 0.95           | 206.0       | 200.0        | 0.97        |
| NorthWest: Hunter St (NW)       |          |           |             |                  |                       |        |           |                |             |              |             |
| P7                              | Full     | 387       | 36.1        | LOS D            | 0.9                   | 0.9    | 0.90      | 0.90           | 202.8       | 200.0        | 0.99        |
| All Pedestrians                 |          | 1832      | 38.0        | LOS D            | 1.5                   | 1.5    | 0.93      | 0.93           | 204.7       | 200.0        | 0.98        |

Level of Service (LOS) Method: SIDRA Pedestrian LOS Method (Based on Average Delay)

Pedestrian movement LOS values are based on average delay per pedestrian movement.

Intersection LOS value for Pedestrians is based on average delay for all pedestrian movements.

**SIDRA INTERSECTION 9.1 | Copyright © 2000-2022 Akcelik and Associates Pty Ltd | sidrasolutions.com**

Organisation: AECOM AUSTRALIA PTY LTD | Licence: NETWORK / Enterprise Level 1 | Processed: Friday, 14 July 2023 11:34:14 AM

Project: C:\Users\YeungMA\AECOM\ANZ-NAC-Sydney Metro-Sydney Metro C&SW Operational Monitoring - General\400\_Technical\432\_Traffic Analysis\SIDRA Modelling\01 Models (Geometry Only)\Block 1\Rev1\_Review\05 SM C&SW\_MPL (Block 1)\_PS.sip9

# MOVEMENT SUMMARY

Site: MPL02 [MPL02 Hunter St / Elizabeth St / Chifley Square  
(Site Folder: Block 1 Model - 2023 AM Peak)]

Output produced by SIDRA INTERSECTION Version: 9.1.1.200

Network: MPL-N1 [MPL  
Network 1 (Network Folder:  
Block 1 Network - 2023 AM  
Peak)]

TCS 302

Site Category: (None)

Signals - EQUISAT (Fixed-Time/SCATS) Coordinated Cycle Time = 90 seconds (Network Site User-Given Phase Times)

| Vehicle Movement Performance   |      |           |              |      |               |      |           |             |                  |                   |        |           |                |                     |             |
|--------------------------------|------|-----------|--------------|------|---------------|------|-----------|-------------|------------------|-------------------|--------|-----------|----------------|---------------------|-------------|
| Mov ID                         | Turn | Mov Class | Demand Flows |      | Arrival Flows |      | Deg. Satn | Aver. Delay | Level of Service | 95% Back Of Queue |        | Prop. Que | Eff. Stop Rate | Aver. No. of Cycles | Aver. Speed |
|                                |      |           | [ Total HV ] | %    | [ Total HV ]  | %    |           |             |                  | [ Veh. veh        | Dist ] |           |                |                     |             |
|                                |      |           | veh/h        | %    | veh/h         | %    | v/c       | sec         |                  | m                 |        |           |                |                     | km/h        |
| South: Elizabeth St (S)        |      |           |              |      |               |      |           |             |                  |                   |        |           |                |                     |             |
| 1                              | L2   | All MCs   | 328          | 14.7 | 328           | 14.7 | 0.369     | 25.1        | LOS B            | 8.0               | 48.5   | 0.60      | 0.70           | 0.60                | 18.4        |
| 3a                             | R1   | All MCs   | 575          | 20.0 | 575           | 20.0 | *0.935    | 61.3        | LOS E            | 33.1              | 271.0  | 1.00      | 1.21           | 1.37                | 8.4         |
| 3                              | R2   | All MCs   | 140          | 8.3  | 140           | 8.3  | 0.408     | 29.4        | LOS C            | 4.9               | 26.9   | 0.88      | 0.77           | 0.88                | 17.7        |
| Approach                       |      |           | 1043         | 16.8 | 1043          | 16.8 | 0.935     | 45.6        | LOS D            | 33.1              | 271.0  | 0.86      | 0.99           | 1.06                | 11.4        |
| East: Hunter St (E)            |      |           |              |      |               |      |           |             |                  |                   |        |           |                |                     |             |
| 4                              | L2   | All MCs   | 121          | 1.7  | 121           | 1.7  | 0.533     | 25.5        | LOS B            | 7.9               | 41.6   | 0.87      | 0.77           | 0.87                | 17.6        |
| 5                              | T1   | All MCs   | 244          | 8.6  | 244           | 8.6  | *0.533    | 32.0        | LOS C            | 7.9               | 41.6   | 0.88      | 0.75           | 0.88                | 11.9        |
| Approach                       |      |           | 365          | 6.3  | 365           | 6.3  | 0.533     | 29.8        | LOS C            | 7.9               | 41.6   | 0.88      | 0.76           | 0.88                | 14.1        |
| NorthEast: Chifley Square (NE) |      |           |              |      |               |      |           |             |                  |                   |        |           |                |                     |             |
| 24b                            | L3   | All MCs   | 54           | 5.9  | 54            | 5.9  | 0.293     | 37.3        | LOS C            | 3.2               | 30.2   | 0.86      | 0.75           | 0.86                | 16.5        |
| 24a                            | L1   | All MCs   | 232          | 36.4 | 232           | 36.4 | 0.443     | 30.1        | LOS C            | 7.2               | 61.9   | 0.86      | 0.76           | 0.86                | 18.0        |
| Approach                       |      |           | 285          | 30.6 | 285           | 30.6 | 0.443     | 31.4        | LOS C            | 7.2               | 61.9   | 0.86      | 0.76           | 0.86                | 17.7        |
| West: Hunter St (W)            |      |           |              |      |               |      |           |             |                  |                   |        |           |                |                     |             |
| 10a                            | L1   | All MCs   | 149          | 9.9  | 149           | 9.9  | 0.430     | 37.0        | LOS C            | 9.3               | 62.6   | 0.93      | 0.80           | 0.93                | 5.3         |
| 11                             | T1   | All MCs   | 102          | 5.2  | 102           | 5.2  | 0.430     | 24.3        | LOS B            | 9.3               | 62.6   | 0.93      | 0.80           | 0.93                | 13.1        |
| 12                             | R2   | All MCs   | 92           | 44.8 | 92            | 44.8 | *0.430    | 36.4        | LOS C            | 4.0               | 33.1   | 0.96      | 0.79           | 0.96                | 12.9        |
| Approach                       |      |           | 343          | 17.8 | 343           | 17.8 | 0.430     | 33.0        | LOS C            | 9.3               | 62.6   | 0.94      | 0.80           | 0.94                | 10.2        |
| All Vehicles                   |      |           | 2037         | 17.0 | 2037          | 17.0 | 0.935     | 38.7        | LOS C            | 33.1              | 271.0  | 0.87      | 0.88           | 0.98                | 12.7        |

Site Level of Service (LOS) Method: Delay (RTA NSW). Site LOS Method is specified in the Network Data dialog (Override Site Data tab).

Vehicle movement LOS values are based on average delay per movement.

Intersection and Approach LOS values are based on average delay for all vehicle movements.

Delay Model: SIDRA Standard (Control Delay: Geometric Delay is included).

Queue Model: SIDRA queue estimation methods are used for Back of Queue and Queue at Start of Green.

Gap-Acceptance Capacity Formula: SIDRA Standard (Akçelik M3D).

HV (%) values are calculated for All Movement Classes of All Heavy Vehicle Model Designation.

Arrival Flows used in performance calculations are adjusted to include any Initial Queued Demand and Upstream Capacity Constraint effects.

\* Critical Movement (Signal Timing)



| Pedestrian Movement Performance |          |           |             |                  |                       |        |           |                |             |              |             |
|---------------------------------|----------|-----------|-------------|------------------|-----------------------|--------|-----------|----------------|-------------|--------------|-------------|
| Mov ID                          | Crossing | Dem. Flow | Aver. Delay | Level of Service | AVERAGE BACK OF QUEUE |        | Prop. Que | Eff. Stop Rate | Travel Time | Travel Dist. | Aver. Speed |
|                                 |          | ped/h     | sec         |                  | [ Ped                 | Dist ] |           |                | sec         | m            | m/sec       |
|                                 |          |           |             |                  | ped                   | m      |           |                |             |              |             |
| South: Elizabeth St (S)         |          |           |             |                  |                       |        |           |                |             |              |             |
| P1                              | Full     | 673       | 33.0        | LOS D            | 1.5                   | 1.5    | 0.87      | 0.87           | 199.7       | 200.0        | 1.00        |
| East: Hunter St (E)             |          |           |             |                  |                       |        |           |                |             |              |             |
| P2                              | Full     | 833       | 38.7        | LOS D            | 2.0                   | 2.0    | 0.94      | 0.94           | 205.4       | 200.0        | 0.97        |
| NorthEast: Chifley Square (NE)  |          |           |             |                  |                       |        |           |                |             |              |             |
| P6                              | Full     | 521       | 32.8        | LOS D            | 1.1                   | 1.1    | 0.86      | 0.86           | 199.5       | 200.0        | 1.00        |
| West: Hunter St (W)             |          |           |             |                  |                       |        |           |                |             |              |             |
| P4                              | Full     | 246       | 35.9        | LOS D            | 0.6                   | 0.6    | 0.90      | 0.90           | 202.6       | 200.0        | 0.99        |
| All Pedestrians                 |          | 2273      | 35.4        | LOS D            | 2.0                   | 2.0    | 0.90      | 0.90           | 202.0       | 200.0        | 0.99        |

Level of Service (LOS) Method: SIDRA Pedestrian LOS Method (Based on Average Delay)  
 Pedestrian movement LOS values are based on average delay per pedestrian movement.  
 Intersection LOS value for Pedestrians is based on average delay for all pedestrian movements.

# MOVEMENT SUMMARY

Site: MPL03 [MPL03 Bent St / Bligh St (Site Folder: Block 1 Model - 2023 AM Peak)]

Output produced by SIDRA INTERSECTION Version: 9.1.1.200

Network: MPL-N1 [MPL Network 1 (Network Folder: Block 1 Network - 2023 AM Peak)]

TCS 1412

Site Category: (None)

Signals - EQUISAT (Fixed-Time/SCATS) Coordinated Cycle Time = 90 seconds (Network Site User-Given Phase Times)

| Vehicle Movement Performance |      |           |              |      |               |      |           |             |                  |                   |        |           |                |                     |             |
|------------------------------|------|-----------|--------------|------|---------------|------|-----------|-------------|------------------|-------------------|--------|-----------|----------------|---------------------|-------------|
| Mov ID                       | Turn | Mov Class | Demand Flows |      | Arrival Flows |      | Deg. Satn | Aver. Delay | Level of Service | 95% Back Of Queue |        | Prop. Que | Eff. Stop Rate | Aver. No. of Cycles | Aver. Speed |
|                              |      |           | [ Total HV ] | %    | [ Total HV ]  | %    |           |             |                  | [ Veh. veh        | Dist ] |           |                |                     |             |
|                              |      |           | veh/h        | %    | veh/h         | %    | v/c       | sec         |                  |                   |        |           |                |                     | km/h        |
| SouthEast: Bent St (SE)      |      |           |              |      |               |      |           |             |                  |                   |        |           |                |                     |             |
| 21                           | L2   | All MCs   | 158          | 26.0 | 158           | 26.0 | 0.273     | 7.5         | LOS A            | 4.2               | 33.9   | 0.35      | 0.45           | 0.35                | 16.7        |
| 22                           | T1   | All MCs   | 473          | 10.2 | 473           | 10.2 | *0.273    | 2.6         | LOS A            | 4.2               | 33.9   | 0.21      | 0.23           | 0.21                | 29.2        |
| Approach                     |      |           | 631          | 14.2 | 631           | 14.2 | 0.273     | 3.8         | LOS A            | 4.2               | 33.9   | 0.24      | 0.29           | 0.24                | 26.3        |
| NorthWest: Bent St (NW)      |      |           |              |      |               |      |           |             |                  |                   |        |           |                |                     |             |
| 28                           | T1   | All MCs   | 123          | 4.3  | 123           | 4.3  | 0.085     | 2.5         | LOS A            | 1.3               | 9.1    | 0.25      | 0.21           | 0.25                | 26.6        |
| 29                           | R2   | All MCs   | 80           | 18.4 | 80            | 18.4 | *0.175    | 8.1         | LOS A            | 1.1               | 9.2    | 0.41      | 0.62           | 0.41                | 15.4        |
| Approach                     |      |           | 203          | 9.8  | 203           | 9.8  | 0.175     | 4.7         | LOS A            | 1.3               | 9.2    | 0.31      | 0.37           | 0.31                | 20.6        |
| All Vehicles                 |      |           | 834          | 13.1 | 834           | 13.1 | 0.273     | 4.0         | LOS A            | 4.2               | 33.9   | 0.26      | 0.31           | 0.26                | 25.0        |

Site Level of Service (LOS) Method: Delay (RTA NSW). Site LOS Method is specified in the Network Data dialog (Override Site Data tab).

Vehicle movement LOS values are based on average delay per movement.

Intersection and Approach LOS values are based on average delay for all vehicle movements.

Delay Model: SIDRA Standard (Control Delay: Geometric Delay is included).

Queue Model: SIDRA queue estimation methods are used for Back of Queue and Queue at Start of Green.

Gap-Acceptance Capacity Formula: SIDRA Standard (Akçelik M3D).

HV (%) values are calculated for All Movement Classes of All Heavy Vehicle Model Designation.

Arrival Flows used in performance calculations are adjusted to include any Initial Queued Demand and Upstream Capacity Constraint effects.

\* Critical Movement (Signal Timing)

| Pedestrian Movement Performance |          |           |             |                  |                       |        |           |                |             |              |             |
|---------------------------------|----------|-----------|-------------|------------------|-----------------------|--------|-----------|----------------|-------------|--------------|-------------|
| Mov ID                          | Crossing | Dem. Flow | Aver. Delay | Level of Service | AVERAGE BACK OF QUEUE |        | Prop. Que | Eff. Stop Rate | Travel Time | Travel Dist. | Aver. Speed |
|                                 |          | ped/h     | sec         |                  | [ Ped                 | Dist ] |           |                | sec         | m            | m/sec       |
|                                 |          |           |             |                  | ped                   | m      |           |                |             |              |             |
| SouthEast: Bent St (SE)         |          |           |             |                  |                       |        |           |                |             |              |             |
| P5                              | Full     | 197       | 35.8        | LOS D            | 0.5                   | 0.5    | 0.90      | 0.90           | 202.5       | 200.0        | 0.99        |
| NorthWest: Bent St (NW)         |          |           |             |                  |                       |        |           |                |             |              |             |
| P7                              | Full     | 504       | 36.3        | LOS D            | 1.2                   | 1.2    | 0.91      | 0.91           | 203.0       | 200.0        | 0.99        |
| SouthWest: Bligh St (SW)        |          |           |             |                  |                       |        |           |                |             |              |             |
| P8                              | Full     | 353       | 37.0        | LOS D            | 0.8                   | 0.8    | 0.91      | 0.91           | 203.7       | 200.0        | 0.98        |
| All Pedestrians                 |          | 1054      | 36.5        | LOS D            | 1.2                   | 1.2    | 0.91      | 0.91           | 203.1       | 200.0        | 0.98        |

Level of Service (LOS) Method: SIDRA Pedestrian LOS Method (Based on Average Delay)

Pedestrian movement LOS values are based on average delay per pedestrian movement.

Intersection LOS value for Pedestrians is based on average delay for all pedestrian movements.

**SIDRA INTERSECTION 9.1 | Copyright © 2000-2022 Akcelik and Associates Pty Ltd | sidrasolutions.com**

Organisation: AECOM AUSTRALIA PTY LTD | Licence: NETWORK / Enterprise Level 1 | Processed: Friday, 14 July 2023 11:34:14 AM

Project: C:\Users\YeungM\AECOM\ANZ-NAC-Sydney Metro-Sydney Metro C&SW Operational Monitoring - General\400\_Technical\432\_Traffic Analysis\SIDRA Modelling\01 Models (Geometry Only)\Block 1\Rev1\_Review\05 SM C&SW\_MPL (Block 1)\_PS.sip9

# MOVEMENT SUMMARY

Site: MPL04 [MPL04 Bent St / Phillip St (Site Folder: Block 1 Model - 2023 AM Peak)]

Output produced by SIDRA INTERSECTION Version: 9.1.1.200

Network: MPL-N1 [MPL Network 1 (Network Folder: Block 1 Network - 2023 AM Peak)]

TCS 242

Site Category: (None)

Signals - EQUISAT (Fixed-Time/SCATS) Coordinated Cycle Time = 90 seconds (Network Site User-Given Phase Times)

| Vehicle Movement Performance |      |           |              |      |               |      |           |             |                  |                   |        |           |                |                     |             |
|------------------------------|------|-----------|--------------|------|---------------|------|-----------|-------------|------------------|-------------------|--------|-----------|----------------|---------------------|-------------|
| Mov ID                       | Turn | Mov Class | Demand Flows |      | Arrival Flows |      | Deg. Satn | Aver. Delay | Level of Service | 95% Back Of Queue |        | Prop. Que | Eff. Stop Rate | Aver. No. of Cycles | Aver. Speed |
|                              |      |           | [ Total HV ] | %    | [ Total HV ]  | %    |           |             |                  | [ Veh. veh        | Dist ] |           |                |                     |             |
|                              |      |           | veh/h        | %    | veh/h         | %    | v/c       | sec         |                  | m                 |        |           |                |                     | km/h        |
| SouthEast: Bent St (SE)      |      |           |              |      |               |      |           |             |                  |                   |        |           |                |                     |             |
| 21                           | L2   | All MCs   | 102          | 35.1 | 102           | 35.1 | 0.132     | 25.4        | LOS B            | 1.0               | 9.1    | 0.24      | 0.50           | 0.24                | 25.9        |
| 22                           | T1   | All MCs   | 380          | 4.4  | 380           | 4.4  | 0.984     | 88.4        | LOS F            | 20.5              | 149.1  | 1.00      | 1.40           | 1.71                | 4.5         |
| 23a                          | R1   | All MCs   | 93           | 3.4  | 93            | 3.4  | *0.984    | 80.7        | LOS F            | 9.1               | 65.7   | 1.00      | 1.33           | 1.86                | 9.2         |
| Approach                     |      |           | 575          | 9.7  | 575           | 9.7  | 0.984     | 75.9        | LOS F            | 20.5              | 149.1  | 0.86      | 1.23           | 1.47                | 6.3         |
| North: Phillip St (N)        |      |           |              |      |               |      |           |             |                  |                   |        |           |                |                     |             |
| 7a                           | L1   | All MCs   | 132          | 7.2  | 132           | 7.2  | *0.167    | 14.4        | LOS A            | 3.2               | 25.5   | 0.54      | 0.62           | 0.54                | 24.5        |
| 9a                           | R1   | All MCs   | 178          | 29.0 | 178           | 29.0 | 0.167     | 8.8         | LOS A            | 3.2               | 25.5   | 0.43      | 0.53           | 0.43                | 25.6        |
| Approach                     |      |           | 309          | 19.7 | 309           | 19.7 | 0.167     | 11.2        | LOS A            | 3.2               | 25.5   | 0.48      | 0.57           | 0.48                | 25.0        |
| NorthWest: Bent St (NW)      |      |           |              |      |               |      |           |             |                  |                   |        |           |                |                     |             |
| 27b                          | L3   | All MCs   | 12           | 0.0  | 12            | 0.0  | 0.240     | 42.5        | LOS D            | 2.1               | 15.2   | 0.82      | 0.64           | 0.82                | 14.4        |
| 28                           | T1   | All MCs   | 102          | 5.2  | 102           | 5.2  | 0.240     | 31.2        | LOS C            | 2.1               | 15.6   | 0.82      | 0.64           | 0.82                | 11.1        |
| 29                           | R2   | All MCs   | 5            | 0.0  | 5             | 0.0  | 0.240     | 46.3        | LOS D            | 2.1               | 15.6   | 0.82      | 0.63           | 0.82                | 5.2         |
| Approach                     |      |           | 119          | 4.4  | 119           | 4.4  | 0.240     | 33.0        | LOS C            | 2.1               | 15.6   | 0.82      | 0.64           | 0.82                | 11.2        |
| SouthWest: Phillip St (SW)   |      |           |              |      |               |      |           |             |                  |                   |        |           |                |                     |             |
| 30                           | L2   | All MCs   | 253          | 25.8 | 253           | 25.8 | 0.271     | 10.5        | LOS A            | 4.6               | 39.7   | 0.45      | 0.64           | 0.45                | 22.6        |
| 30a                          | L1   | All MCs   | 313          | 19.2 | 313           | 19.2 | 0.268     | 7.4         | LOS A            | 5.6               | 45.9   | 0.45      | 0.49           | 0.45                | 31.3        |
| 32                           | R2   | All MCs   | 159          | 2.6  | 159           | 2.6  | *0.277    | 17.2        | LOS B            | 4.3               | 31.0   | 0.76      | 0.68           | 0.76                | 21.7        |
| Approach                     |      |           | 724          | 17.9 | 724           | 17.9 | 0.277     | 10.7        | LOS A            | 5.6               | 45.9   | 0.52      | 0.58           | 0.52                | 26.5        |
| All Vehicles                 |      |           | 1727         | 14.6 | 1727          | 14.6 | 0.984     | 34.0        | LOS C            | 20.5              | 149.1  | 0.65      | 0.80           | 0.85                | 14.7        |

Site Level of Service (LOS) Method: Delay (RTA NSW). Site LOS Method is specified in the Network Data dialog (Override Site Data tab).

Vehicle movement LOS values are based on average delay per movement.

Intersection and Approach LOS values are based on average delay for all vehicle movements.

Delay Model: SIDRA Standard (Control Delay: Geometric Delay is included).

Queue Model: SIDRA queue estimation methods are used for Back of Queue and Queue at Start of Green.

Gap-Acceptance Capacity Formula: SIDRA Standard (Akçelik M3D).

HV (%) values are calculated for All Movement Classes of All Heavy Vehicle Model Designation.

Arrival Flows used in performance calculations are adjusted to include any Initial Queued Demand and Upstream Capacity Constraint effects.

\* Critical Movement (Signal Timing)

| Pedestrian Movement Performance |          |           |             |                  |                       |        |           |                |             |              |             |
|---------------------------------|----------|-----------|-------------|------------------|-----------------------|--------|-----------|----------------|-------------|--------------|-------------|
| Mov ID                          | Crossing | Dem. Flow | Aver. Delay | Level of Service | AVERAGE BACK OF QUEUE |        | Prop. Que | Eff. Stop Rate | Travel Time | Travel Dist. | Aver. Speed |
|                                 |          | ped/h     | sec         |                  | [ Ped                 | Dist ] |           |                | sec         | m            | m/sec       |
|                                 |          |           |             |                  | ped                   | m      |           |                |             |              |             |
| SouthEast: Bent St (SE)         |          |           |             |                  |                       |        |           |                |             |              |             |
| P5                              | Full     | 640       | 34.7        | LOS D            | 1.5                   | 1.5    | 0.89      | 0.89           | 201.4       | 200.0        | 0.99        |
| North: Phillip St (N)           |          |           |             |                  |                       |        |           |                |             |              |             |
| P3                              | Full     | 538       | 36.4        | LOS D            | 1.3                   | 1.3    | 0.91      | 0.91           | 203.0       | 200.0        | 0.99        |
| NorthWest: Bent St (NW)         |          |           |             |                  |                       |        |           |                |             |              |             |
| P7                              | Full     | 386       | 36.1        | LOS D            | 0.9                   | 0.9    | 0.90      | 0.90           | 202.8       | 200.0        | 0.99        |
| SouthWest: Phillip St (SW)      |          |           |             |                  |                       |        |           |                |             |              |             |
| P8                              | Full     | 529       | 34.6        | LOS D            | 1.2                   | 1.2    | 0.89      | 0.89           | 201.2       | 200.0        | 0.99        |
| All Pedestrians                 |          | 2094      | 35.4        | LOS D            | 1.5                   | 1.5    | 0.90      | 0.90           | 202.0       | 200.0        | 0.99        |

Level of Service (LOS) Method: SIDRA Pedestrian LOS Method (Based on Average Delay)

Pedestrian movement LOS values are based on average delay per pedestrian movement.

Intersection LOS value for Pedestrians is based on average delay for all pedestrian movements.

**SIDRA INTERSECTION 9.1 | Copyright © 2000-2022 Akcelik and Associates Pty Ltd | sidrasolutions.com**

Organisation: AECOM AUSTRALIA PTY LTD | Licence: NETWORK / Enterprise Level 1 | Processed: Friday, 14 July 2023 11:34:14 AM

Project: C:\Users\YeungMA\AECOM\ANZ-NAC-Sydney Metro-Sydney Metro C&SW Operational Monitoring - General\400\_Technical\432\_Traffic Analysis\SIDRA Modelling\01 Models (Geometry Only)\Block 1\Rev1\_Review\05 SM C&SW\_MPL (Block 1)\_PS.sip9

# MOVEMENT SUMMARY

 Site: MPL05 [MPL05 Pedestrian Mid-block Crossing at Castlereagh St (Site Folder: Block 1 Model - 2023 AM Peak)]

Output produced by SIDRA INTERSECTION Version: 9.1.1.200

TCS 245

Site Category: (None)

Pedestrian Crossing (Signalised) - EQUISAT (Fixed-Time/SCATS) Isolated Cycle Time = 47 seconds (Site User-Given Phase Times)

| Vehicle Movement Performance |      |           |                       |      |                       |      |           |             |                  |                   |               |           |                |                     |             |
|------------------------------|------|-----------|-----------------------|------|-----------------------|------|-----------|-------------|------------------|-------------------|---------------|-----------|----------------|---------------------|-------------|
| Mov ID                       | Turn | Mov Class | Demand Flows          |      | Arrival Flows         |      | Deg. Satn | Aver. Delay | Level of Service | 95% Back Of Queue |               | Prop. Que | Eff. Stop Rate | Aver. No. of Cycles | Aver. Speed |
|                              |      |           | [ Total HV ]<br>veh/h | %    | [ Total HV ]<br>veh/h | %    |           |             |                  | [ Veh. ]<br>veh   | [ Dist ]<br>m |           |                |                     |             |
| North: Castlereagh St (N)    |      |           |                       |      |                       |      |           |             |                  |                   |               |           |                |                     |             |
| 8                            | T1   | All MCs   | 484                   | 17.2 | 484                   | 17.2 | * 0.699   | 14.6        | LOS B            | 9.7               | 75.8          | 0.89      | 0.82           | 0.96                | 25.0        |
| Approach                     |      |           | 484                   | 17.2 | 484                   | 17.2 | 0.699     | 14.6        | LOS B            | 9.7               | 75.8          | 0.89      | 0.82           | 0.96                | 25.0        |
| All Vehicles                 |      |           | 484                   | 17.2 | 484                   | 17.2 | 0.699     | 14.6        | LOS B            | 9.7               | 75.8          | 0.89      | 0.82           | 0.96                | 25.0        |

Site Level of Service (LOS) Method: Delay (RTA NSW). Site LOS Method is specified in the Parameter Settings dialog (Options tab).

Vehicle movement LOS values are based on average delay per movement.

Intersection and Approach LOS values are based on average delay for all vehicle movements.

Delay Model: SIDRA Standard (Control Delay: Geometric Delay is included).

Queue Model: SIDRA queue estimation methods are used for Back of Queue and Queue at Start of Green.

Gap-Acceptance Capacity Formula: SIDRA Standard (Akçelik M3D).

HV (%) values are calculated for All Movement Classes of All Heavy Vehicle Model Designation.

Arrival Flows used in performance calculations are adjusted to include any Initial Queued Demand and Upstream Capacity Constraint effects.

\* Critical Movement (Signal Timing)

| Pedestrian Movement Performance |          |            |           |             |                  |                       |        |           |                |             |              |             |
|---------------------------------|----------|------------|-----------|-------------|------------------|-----------------------|--------|-----------|----------------|-------------|--------------|-------------|
| Mov ID                          | Crossing | Input Vol. | Dem. Flow | Aver. Delay | Level of Service | AVERAGE BACK OF QUEUE |        | Prop. Que | Eff. Stop Rate | Travel Time | Travel Dist. | Aver. Speed |
|                                 |          | ped/h      | ped/h     | sec         |                  | [ Ped                 | Dist ] |           |                | sec         | m            | m/sec       |
|                                 |          |            |           |             |                  | ped                   | m      |           |                |             |              |             |
| South: Castlereagh St (S)       |          |            |           |             |                  |                       |        |           |                |             |              |             |
| P1                              | Full     | 2824       | 2973      | 17.5        | LOS B            | 3.7                   | 3.7    | 0.92      | 0.92           | 184.2       | 200.0        | 1.09        |
| All                             |          | 2824       | 2973      | 17.5        | LOS B            | 3.7                   | 3.7    | 0.92      | 0.92           | 184.2       | 200.0        | 1.09        |
| Pedestrians                     |          |            |           |             |                  |                       |        |           |                |             |              |             |

Level of Service (LOS) Method: SIDRA Pedestrian LOS Method (Based on Average Delay)

Pedestrian movement LOS values are based on average delay per pedestrian movement.

Intersection LOS value for Pedestrians is based on average delay for all pedestrian movements.

**SIDRA INTERSECTION 9.1 | Copyright © 2000-2022 Akcelik and Associates Pty Ltd | sidrasolutions.com**

Organisation: AECOM AUSTRALIA PTY LTD | Licence: NETWORK / Enterprise Level 1 | Processed: Friday, 14 July 2023 11:34:05 AM

Project: C:\Users\Yeung\MAECOMANZ-NAC-Sydney Metro-Sydney Metro C&SW Operational Monitoring - General\400\_Technical\432\_Traffic Analysis\SIDRA Modelling\01 Models (Geometry Only)\Block 1\Rev1\_Review\05 SM C&SW\_MPL (Block 1)\_PS.sip9

# MOVEMENT SUMMARY

 Site: MPL06 [MPL06 Pedestrian Mid-block Crossing at Elizabeth St (Site Folder: Block 1 Model - 2023 AM Peak)]

Output produced by SIDRA INTERSECTION Version: 9.1.1.200

TCS 287

Site Category: (None)

Pedestrian Crossing (Signalised) - EQUISAT (Fixed-Time/SCATS) Isolated Cycle Time = 72 seconds (Site User-Given Phase Times)

| Vehicle Movement Performance |      |           |                       |      |                       |      |           |             |                  |                   |               |           |                |                     |             |
|------------------------------|------|-----------|-----------------------|------|-----------------------|------|-----------|-------------|------------------|-------------------|---------------|-----------|----------------|---------------------|-------------|
| Mov ID                       | Turn | Mov Class | Demand Flows          |      | Arrival Flows         |      | Deg. Satn | Aver. Delay | Level of Service | 95% Back Of Queue |               | Prop. Que | Eff. Stop Rate | Aver. No. of Cycles | Aver. Speed |
|                              |      |           | [ Total HV ]<br>veh/h | %    | [ Total HV ]<br>veh/h | %    |           |             |                  | [ Veh. ]<br>veh   | [ Dist ]<br>m |           |                |                     |             |
| South: Elizabeth St (S)      |      |           |                       |      |                       |      |           |             |                  |                   |               |           |                |                     |             |
| 2                            | T1   | All MCs   | 1041                  | 15.5 | 1041                  | 15.5 | * 0.542   | 14.4        | LOS A            | 11.4              | 90.6          | 0.66      | 0.58           | 0.66                | 27.8        |
| Approach                     |      |           | 1041                  | 15.5 | 1041                  | 15.5 | 0.542     | 11.6        | LOS A            | 11.4              | 90.6          | 0.66      | 0.58           | 0.66                | 27.8        |
| North: Elizabeth St (N)      |      |           |                       |      |                       |      |           |             |                  |                   |               |           |                |                     |             |
| 8                            | T1   | All MCs   | 457                   | 28.1 | 457                   | 28.1 | 0.340     | 9.3         | LOS A            | 6.7               | 49.2          | 0.57      | 0.49           | 0.57                | 29.0        |
| Approach                     |      |           | 457                   | 28.1 | 457                   | 28.1 | 0.340     | 9.3         | LOS A            | 6.7               | 49.2          | 0.57      | 0.49           | 0.57                | 29.0        |
| All Vehicles                 |      |           | 1498                  | 19.3 | 1498                  | 19.3 | 0.542     | 12.9        | LOS A            | 11.4              | 90.6          | 0.64      | 0.55           | 0.64                | 28.1        |

Site Level of Service (LOS) Method: Delay (RTA NSW). Site LOS Method is specified in the Parameter Settings dialog (Options tab).

Vehicle movement LOS values are based on average delay per movement.

Intersection and Approach LOS values are based on average delay for all vehicle movements.

Delay Model: SIDRA Standard (Control Delay: Geometric Delay is included).

Queue Model: SIDRA queue estimation methods are used for Back of Queue and Queue at Start of Green.

Gap-Acceptance Capacity Formula: SIDRA Standard (Akçelik M3D).

HV (%) values are calculated for All Movement Classes of All Heavy Vehicle Model Designation.

Arrival Flows used in performance calculations are adjusted to include any Initial Queued Demand and Upstream Capacity Constraint effects.

\* Critical Movement (Signal Timing)



| Pedestrian Movement Performance |          |       |       |       |                  |                       |        |           |                |             |              |             |       |
|---------------------------------|----------|-------|-------|-------|------------------|-----------------------|--------|-----------|----------------|-------------|--------------|-------------|-------|
| Mov ID                          | Crossing | Input | Dem.  | Aver. | Level of Service | AVERAGE BACK OF QUEUE |        | Prop. Que | Eff. Stop Rate | Travel Time | Travel Dist. | Aver. Speed |       |
|                                 |          | Vol.  | Flow  | Delay |                  | [ Ped                 | Dist ] |           |                |             |              |             |       |
|                                 |          | ped/h | ped/h | sec   |                  |                       | ped    | m         |                |             | sec          | m           | m/sec |
| South: Elizabeth St (S)         |          |       |       |       |                  |                       |        |           |                |             |              |             |       |
| P1                              | Full     | 3716  | 3912  | 31.9  | LOS D            | 8.2                   | 8.2    | 1.03      | 1.03           | 198.6       | 200.0        | 1.01        |       |
| All                             |          | 3716  | 3912  | 31.9  | LOS D            | 8.2                   | 8.2    | 1.03      | 1.03           | 198.6       | 200.0        | 1.01        |       |
| Pedestrians                     |          |       |       |       |                  |                       |        |           |                |             |              |             |       |

Level of Service (LOS) Method: SIDRA Pedestrian LOS Method (Based on Average Delay)

Pedestrian movement LOS values are based on average delay per pedestrian movement.

Intersection LOS value for Pedestrians is based on average delay for all pedestrian movements.

---

**SIDRA INTERSECTION 9.1 | Copyright © 2000-2022 Akcelik and Associates Pty Ltd | sidrasolutions.com**

Organisation: AECOM AUSTRALIA PTY LTD | Licence: NETWORK / Enterprise Level 1 | Processed: Friday, 14 July 2023 11:34:06 AM

Project: C:\Users\YeungMAE\COMANZ-NAC-Sydney Metro-Sydney Metro C&SW Operational Monitoring - General\400\_Technical\432\_Traffic Analysis\SIDRA Modelling\01 Models (Geometry Only)\Block 1\Rev1\_Review\05 SM C&SW\_MPL (Block 1)\_PS.sip9

# MOVEMENT SUMMARY

Site: MPL01 [MPL01 Hunter St / Castlereagh St / Bligh St (Site Folder: Block 1 Model - 2023 PM Peak)]

Output produced by SIDRA INTERSECTION Version: 9.1.1.200

Network: MPL-N1 [MPL Network 1 (Network Folder: Block 1 Network - 2023 PM Peak)]

TCS 244

Site Category: (None)

Signals - EQUISAT (Fixed-Time/SCATS) Coordinated Cycle Time = 90 seconds (Network Site User-Given Phase Times)

| Vehicle Movement Performance |      |           |              |              |               |          |           |             |                  |                   |      |           |                |                     |             |
|------------------------------|------|-----------|--------------|--------------|---------------|----------|-----------|-------------|------------------|-------------------|------|-----------|----------------|---------------------|-------------|
| Mov ID                       | Turn | Mov Class | Demand Flows |              | Arrival Flows |          | Deg. Satn | Aver. Delay | Level of Service | 95% Back Of Queue |      | Prop. Que | Eff. Stop Rate | Aver. No. of Cycles | Aver. Speed |
|                              |      |           | [ Total HV ] | [ Total HV ] | [ Veh. veh ]  | [ Dist ] |           |             |                  | v/c               | sec  |           |                |                     |             |
| East: Hunter St (E)          |      |           |              |              |               |          |           |             |                  |                   |      |           |                |                     |             |
| 4                            | L2   | All MCs   | 172          | 20.2         | 172           | 20.2     | *0.319    | 20.2        | LOS B            | 5.6               | 44.8 | 0.64      | 0.69           | 0.64                | 18.4        |
| 6a                           | R1   | All MCs   | 328          | 0.6          | 328           | 0.6      | 0.319     | 14.1        | LOS A            | 6.6               | 46.3 | 0.56      | 0.61           | 0.56                | 19.8        |
| Approach                     |      |           | 500          | 7.4          | 500           | 7.4      | 0.319     | 16.2        | LOS B            | 6.6               | 46.3 | 0.59      | 0.64           | 0.59                | 19.2        |
| North: Bligh St (N)          |      |           |              |              |               |          |           |             |                  |                   |      |           |                |                     |             |
| 7                            | L2   | All MCs   | 123          | 15.4         | 123           | 15.4     | *0.665    | 59.1        | LOS E            | 5.3               | 33.3 | 0.97      | 0.83           | 1.05                | 11.1        |
| 8                            | T1   | All MCs   | 126          | 11.7         | 126           | 11.7     | 0.190     | 40.5        | LOS C            | 2.7               | 15.9 | 0.86      | 0.67           | 0.86                | 18.9        |
| 9b                           | R3   | All MCs   | 11           | 0.0          | 11            | 0.0      | 0.190     | 43.2        | LOS D            | 2.3               | 14.2 | 0.86      | 0.68           | 0.86                | 17.1        |
| Approach                     |      |           | 260          | 13.0         | 260           | 13.0     | 0.665     | 49.4        | LOS D            | 5.3               | 33.3 | 0.91      | 0.75           | 0.95                | 15.2        |
| NorthWest: Hunter St (NW)    |      |           |              |              |               |          |           |             |                  |                   |      |           |                |                     |             |
| 27a                          | L1   | All MCs   | 379          | 6.9          | 379           | 6.9      | 0.396     | 11.2        | LOS A            | 5.9               | 43.3 | 0.56      | 0.64           | 0.56                | 19.2        |
| 29a                          | R1   | All MCs   | 117          | 3.6          | 117           | 3.6      | *0.396    | 12.8        | LOS A            | 5.9               | 43.3 | 0.61      | 0.67           | 0.61                | 25.4        |
| Approach                     |      |           | 496          | 6.2          | 496           | 6.2      | 0.396     | 11.6        | LOS A            | 5.9               | 43.3 | 0.57      | 0.65           | 0.57                | 21.3        |
| All Vehicles                 |      |           | 1256         | 8.0          | 1256          | 8.0      | 0.665     | 21.3        | LOS B            | 6.6               | 46.3 | 0.65      | 0.67           | 0.66                | 18.4        |

Site Level of Service (LOS) Method: Delay (RTA NSW). Site LOS Method is specified in the Network Data dialog (Override Site Data tab).

Vehicle movement LOS values are based on average delay per movement.

Intersection and Approach LOS values are based on average delay for all vehicle movements.

Delay Model: SIDRA Standard (Control Delay: Geometric Delay is included).

Queue Model: SIDRA queue estimation methods are used for Back of Queue and Queue at Start of Green.

Gap-Acceptance Capacity Formula: SIDRA Standard (Akçelik M3D).

HV (%) values are calculated for All Movement Classes of All Heavy Vehicle Model Designation.

Arrival Flows used in performance calculations are adjusted to include any Initial Queued Demand and Upstream Capacity Constraint effects.

\* Critical Movement (Signal Timing)

| Pedestrian Movement Performance |          |           |             |                  |                       |        |           |                |             |              |             |
|---------------------------------|----------|-----------|-------------|------------------|-----------------------|--------|-----------|----------------|-------------|--------------|-------------|
| Mov ID                          | Crossing | Dem. Flow | Aver. Delay | Level of Service | AVERAGE BACK OF QUEUE |        | Prop. Que | Eff. Stop Rate | Travel Time | Travel Dist. | Aver. Speed |
|                                 |          | ped/h     | sec         |                  | [ Ped                 | Dist ] |           |                | sec         | m            | m/sec       |
|                                 |          |           |             |                  | ped                   | m      |           |                |             |              |             |
| South: Castlereagh St (S)       |          |           |             |                  |                       |        |           |                |             |              |             |
| P1                              | Full     | 669       | 39.4        | LOS D            | 1.6                   | 1.6    | 0.95      | 0.95           | 206.0       | 200.0        | 0.97        |
| East: Hunter St (E)             |          |           |             |                  |                       |        |           |                |             |              |             |
| P2                              | Full     | 297       | 35.1        | LOS D            | 0.7                   | 0.7    | 0.89      | 0.89           | 201.8       | 200.0        | 0.99        |
| North: Bligh St (N)             |          |           |             |                  |                       |        |           |                |             |              |             |
| P3                              | Full     | 326       | 38.8        | LOS D            | 0.8                   | 0.8    | 0.93      | 0.93           | 205.5       | 200.0        | 0.97        |
| NorthWest: Hunter St (NW)       |          |           |             |                  |                       |        |           |                |             |              |             |
| P7                              | Full     | 435       | 36.2        | LOS D            | 1.0                   | 1.0    | 0.91      | 0.91           | 202.9       | 200.0        | 0.99        |
| All Pedestrians                 |          | 1727      | 37.7        | LOS D            | 1.6                   | 1.6    | 0.92      | 0.92           | 204.4       | 200.0        | 0.98        |

Level of Service (LOS) Method: SIDRA Pedestrian LOS Method (Based on Average Delay)

Pedestrian movement LOS values are based on average delay per pedestrian movement.

Intersection LOS value for Pedestrians is based on average delay for all pedestrian movements.

**SIDRA INTERSECTION 9.1 | Copyright © 2000-2022 Akcelik and Associates Pty Ltd | sidrasolutions.com**

Organisation: AECOM AUSTRALIA PTY LTD | Licence: NETWORK / Enterprise Level 1 | Processed: Friday, 14 July 2023 11:34:17 AM

Project: C:\Users\YeungMA\AECOM\ANZ-NAC-Sydney Metro-Sydney Metro C&SW Operational Monitoring - General\400\_Technical\432\_Traffic Analysis\SIDRA Modelling\01 Models (Geometry Only)\Block 1\Rev1\_Review\05 SM C&SW\_MPL (Block 1)\_PS.sip9

# MOVEMENT SUMMARY

Site: MPL02 [MPL02 Hunter St / Elizabeth St / Chifley Square  
(Site Folder: Block 1 Model - 2023 PM Peak)]

Output produced by SIDRA INTERSECTION Version: 9.1.1.200

Network: MPL-N1 [MPL  
Network 1 (Network Folder:  
Block 1 Network - 2023 PM  
Peak)]

TCS 302

Site Category: (None)

Signals - EQUISAT (Fixed-Time/SCATS) Coordinated Cycle Time = 90 seconds (Network Site User-Given Phase Times)

| Vehicle Movement Performance   |      |           |              |      |               |      |           |             |                  |                   |        |           |                |                     |             |
|--------------------------------|------|-----------|--------------|------|---------------|------|-----------|-------------|------------------|-------------------|--------|-----------|----------------|---------------------|-------------|
| Mov ID                         | Turn | Mov Class | Demand Flows |      | Arrival Flows |      | Deg. Satn | Aver. Delay | Level of Service | 95% Back Of Queue |        | Prop. Que | Eff. Stop Rate | Aver. No. of Cycles | Aver. Speed |
|                                |      |           | [ Total HV ] | %    | [ Total HV ]  | %    |           |             |                  | [ Veh. veh        | Dist ] |           |                |                     |             |
|                                |      |           | veh/h        | %    | veh/h         | %    | v/c       | sec         |                  |                   | m      |           |                |                     | km/h        |
| South: Elizabeth St (S)        |      |           |              |      |               |      |           |             |                  |                   |        |           |                |                     |             |
| 1                              | L2   | All MCs   | 254          | 2.1  | 254           | 2.1  | 0.242     | 24.1        | LOS B            | 5.4               | 27.9   | 0.52      | 0.66           | 0.52                | 19.8        |
| 3a                             | R1   | All MCs   | 633          | 13.6 | 633           | 13.6 | *0.909    | 54.0        | LOS D            | 33.1              | 259.0  | 1.00      | 1.11           | 1.27                | 9.7         |
| 3                              | R2   | All MCs   | 131          | 0.8  | 131           | 0.8  | 0.332     | 28.3        | LOS B            | 4.4               | 22.5   | 0.86      | 0.76           | 0.86                | 18.1        |
| Approach                       |      |           | 1017         | 9.1  | 1017          | 9.1  | 0.909     | 43.2        | LOS D            | 33.1              | 259.0  | 0.86      | 0.95           | 1.03                | 12.2        |
| East: Hunter St (E)            |      |           |              |      |               |      |           |             |                  |                   |        |           |                |                     |             |
| 4                              | L2   | All MCs   | 109          | 4.8  | 109           | 4.8  | 0.391     | 23.4        | LOS B            | 6.8               | 38.3   | 0.83      | 0.74           | 0.83                | 18.0        |
| 5                              | T1   | All MCs   | 238          | 13.3 | 238           | 13.3 | *0.391    | 31.2        | LOS C            | 6.8               | 38.3   | 0.85      | 0.72           | 0.85                | 12.3        |
| Approach                       |      |           | 347          | 10.6 | 347           | 10.6 | 0.391     | 28.7        | LOS C            | 6.8               | 38.3   | 0.84      | 0.72           | 0.84                | 14.4        |
| NorthEast: Chifley Square (NE) |      |           |              |      |               |      |           |             |                  |                   |        |           |                |                     |             |
| 24b                            | L3   | All MCs   | 32           | 10.0 | 32            | 10.0 | 0.319     | 40.2        | LOS C            | 2.9               | 31.7   | 0.87      | 0.74           | 0.87                | 16.2        |
| 24a                            | L1   | All MCs   | 282          | 19.0 | 282           | 19.0 | 0.481     | 33.2        | LOS C            | 9.1               | 65.3   | 0.90      | 0.78           | 0.90                | 17.1        |
| Approach                       |      |           | 314          | 18.1 | 314           | 18.1 | 0.481     | 33.9        | LOS C            | 9.1               | 65.3   | 0.90      | 0.78           | 0.90                | 17.0        |
| West: Hunter St (W)            |      |           |              |      |               |      |           |             |                  |                   |        |           |                |                     |             |
| 10a                            | L1   | All MCs   | 196          | 0.5  | 196           | 0.5  | 0.504     | 37.8        | LOS C            | 10.2              | 65.3   | 0.94      | 0.82           | 0.94                | 5.1         |
| 11                             | T1   | All MCs   | 214          | 2.5  | 214           | 2.5  | 0.504     | 25.0        | LOS B            | 10.2              | 65.3   | 0.94      | 0.80           | 0.94                | 13.5        |
| 12                             | R2   | All MCs   | 93           | 40.9 | 93            | 40.9 | *0.504    | 35.6        | LOS C            | 7.7               | 50.4   | 0.93      | 0.78           | 0.93                | 14.4        |
| Approach                       |      |           | 502          | 8.8  | 502           | 8.8  | 0.504     | 31.9        | LOS C            | 10.2              | 65.3   | 0.94      | 0.80           | 0.94                | 10.8        |
| All Vehicles                   |      |           | 2180         | 10.6 | 2180          | 10.6 | 0.909     | 37.0        | LOS C            | 33.1              | 259.0  | 0.88      | 0.86           | 0.96                | 13.1        |

Site Level of Service (LOS) Method: Delay (RTA NSW). Site LOS Method is specified in the Network Data dialog (Override Site Data tab).

Vehicle movement LOS values are based on average delay per movement.

Intersection and Approach LOS values are based on average delay for all vehicle movements.

Delay Model: SIDRA Standard (Control Delay: Geometric Delay is included).

Queue Model: SIDRA queue estimation methods are used for Back of Queue and Queue at Start of Green.

Gap-Acceptance Capacity Formula: SIDRA Standard (Akçelik M3D).

HV (%) values are calculated for All Movement Classes of All Heavy Vehicle Model Designation.

Arrival Flows used in performance calculations are adjusted to include any Initial Queued Demand and Upstream Capacity Constraint effects.

\* Critical Movement (Signal Timing)

| Pedestrian Movement Performance |          |           |             |                  |                       |        |           |                |             |              |             |
|---------------------------------|----------|-----------|-------------|------------------|-----------------------|--------|-----------|----------------|-------------|--------------|-------------|
| Mov ID                          | Crossing | Dem. Flow | Aver. Delay | Level of Service | AVERAGE BACK OF QUEUE |        | Prop. Que | Eff. Stop Rate | Travel Time | Travel Dist. | Aver. Speed |
|                                 |          | ped/h     | sec         |                  | [ Ped                 | Dist ] |           |                | sec         | m            | m/sec       |
|                                 |          |           |             |                  | ped                   | m      |           |                |             |              |             |
| South: Elizabeth St (S)         |          |           |             |                  |                       |        |           |                |             |              |             |
| P1                              | Full     | 688       | 33.0        | LOS D            | 1.5                   | 1.5    | 0.87      | 0.87           | 199.7       | 200.0        | 1.00        |
| East: Hunter St (E)             |          |           |             |                  |                       |        |           |                |             |              |             |
| P2                              | Full     | 847       | 38.7        | LOS D            | 2.0                   | 2.0    | 0.94      | 0.94           | 205.4       | 200.0        | 0.97        |
| NorthEast: Chifley Square (NE)  |          |           |             |                  |                       |        |           |                |             |              |             |
| P6                              | Full     | 458       | 32.7        | LOS D            | 1.0                   | 1.0    | 0.86      | 0.86           | 199.4       | 200.0        | 1.00        |
| West: Hunter St (W)             |          |           |             |                  |                       |        |           |                |             |              |             |
| P4                              | Full     | 209       | 35.9        | LOS D            | 0.5                   | 0.5    | 0.90      | 0.90           | 202.5       | 200.0        | 0.99        |
| All Pedestrians                 |          | 2203      | 35.4        | LOS D            | 2.0                   | 2.0    | 0.90      | 0.90           | 202.1       | 200.0        | 0.99        |

Level of Service (LOS) Method: SIDRA Pedestrian LOS Method (Based on Average Delay)

Pedestrian movement LOS values are based on average delay per pedestrian movement.

Intersection LOS value for Pedestrians is based on average delay for all pedestrian movements.

**SIDRA INTERSECTION 9.1 | Copyright © 2000-2022 Akcelik and Associates Pty Ltd | sidrasolutions.com**

Organisation: AECOM AUSTRALIA PTY LTD | Licence: NETWORK / Enterprise Level 1 | Processed: Friday, 14 July 2023 11:34:17 AM

Project: C:\Users\YeungMA\AECOM\ANZ-NAC-Sydney Metro-Sydney Metro C&SW Operational Monitoring - General\400\_Technical\432\_Traffic Analysis\SIDRA Modelling\01 Models (Geometry Only)\Block 1\Rev1\_Review\05 SM C&SW\_MPL (Block 1)\_PS.sip9

# MOVEMENT SUMMARY

Site: MPL03 [MPL03 Bent St / Bligh St (Site Folder: Block 1 Model - 2023 PM Peak)]

Output produced by SIDRA INTERSECTION Version: 9.1.1.200

Network: MPL-N1 [MPL Network 1 (Network Folder: Block 1 Network - 2023 PM Peak)]

TCS 1412

Site Category: (None)

Signals - EQUISAT (Fixed-Time/SCATS) Coordinated Cycle Time = 90 seconds (Network Site User-Given Phase Times)

| Vehicle Movement Performance |      |           |              |      |               |      |           |             |                  |                   |        |           |                |                     |             |
|------------------------------|------|-----------|--------------|------|---------------|------|-----------|-------------|------------------|-------------------|--------|-----------|----------------|---------------------|-------------|
| Mov ID                       | Turn | Mov Class | Demand Flows |      | Arrival Flows |      | Deg. Satn | Aver. Delay | Level of Service | 95% Back Of Queue |        | Prop. Que | Eff. Stop Rate | Aver. No. of Cycles | Aver. Speed |
|                              |      |           | [ Total HV ] | %    | [ Total HV ]  | %    |           |             |                  | [ Veh. veh        | Dist ] |           |                |                     |             |
|                              |      |           | veh/h        | %    | veh/h         | %    | v/c       | sec         |                  |                   |        |           |                |                     | km/h        |
| SouthEast: Bent St (SE)      |      |           |              |      |               |      |           |             |                  |                   |        |           |                |                     |             |
| 21                           | L2   | All MCs   | 144          | 21.9 | 144           | 21.9 | 0.239     | 6.8         | LOS A            | 3.0               | 23.3   | 0.27      | 0.41           | 0.27                | 18.3        |
| 22                           | T1   | All MCs   | 420          | 5.8  | 420           | 5.8  | *0.239    | 3.3         | LOS A            | 3.0               | 23.3   | 0.25      | 0.27           | 0.25                | 27.6        |
| Approach                     |      |           | 564          | 9.9  | 564           | 9.9  | 0.239     | 4.1         | LOS A            | 3.0               | 23.3   | 0.26      | 0.30           | 0.26                | 25.6        |
| NorthWest: Bent St (NW)      |      |           |              |      |               |      |           |             |                  |                   |        |           |                |                     |             |
| 28                           | T1   | All MCs   | 199          | 0.0  | 199           | 0.0  | 0.133     | 2.9         | LOS A            | 2.2               | 15.5   | 0.28      | 0.23           | 0.28                | 25.3        |
| 29                           | R2   | All MCs   | 86           | 2.4  | 86            | 2.4  | *0.152    | 7.7         | LOS A            | 1.1               | 8.2    | 0.39      | 0.61           | 0.39                | 16.0        |
| Approach                     |      |           | 285          | 0.7  | 285           | 0.7  | 0.152     | 4.3         | LOS A            | 2.2               | 15.5   | 0.31      | 0.35           | 0.31                | 21.4        |
| All Vehicles                 |      |           | 849          | 6.8  | 849           | 6.8  | 0.239     | 4.2         | LOS A            | 3.0               | 23.3   | 0.27      | 0.32           | 0.27                | 24.4        |

Site Level of Service (LOS) Method: Delay (RTA NSW). Site LOS Method is specified in the Network Data dialog (Override Site Data tab).

Vehicle movement LOS values are based on average delay per movement.

Intersection and Approach LOS values are based on average delay for all vehicle movements.

Delay Model: SIDRA Standard (Control Delay: Geometric Delay is included).

Queue Model: SIDRA queue estimation methods are used for Back of Queue and Queue at Start of Green.

Gap-Acceptance Capacity Formula: SIDRA Standard (Akçelik M3D).

HV (%) values are calculated for All Movement Classes of All Heavy Vehicle Model Designation.

Arrival Flows used in performance calculations are adjusted to include any Initial Queued Demand and Upstream Capacity Constraint effects.

\* Critical Movement (Signal Timing)

| Pedestrian Movement Performance |          |           |             |                  |                       |        |           |                |             |              |             |
|---------------------------------|----------|-----------|-------------|------------------|-----------------------|--------|-----------|----------------|-------------|--------------|-------------|
| Mov ID                          | Crossing | Dem. Flow | Aver. Delay | Level of Service | AVERAGE BACK OF QUEUE |        | Prop. Que | Eff. Stop Rate | Travel Time | Travel Dist. | Aver. Speed |
|                                 |          | ped/h     | sec         |                  | [ Ped                 | Dist ] |           |                | sec         | m            | m/sec       |
|                                 |          |           |             |                  | ped                   | m      |           |                |             |              |             |
| SouthEast: Bent St (SE)         |          |           |             |                  |                       |        |           |                |             |              |             |
| P5                              | Full     | 187       | 35.8        | LOS D            | 0.4                   | 0.4    | 0.90      | 0.90           | 202.5       | 200.0        | 0.99        |
| NorthWest: Bent St (NW)         |          |           |             |                  |                       |        |           |                |             |              |             |
| P7                              | Full     | 742       | 36.7        | LOS D            | 1.7                   | 1.7    | 0.92      | 0.92           | 203.4       | 200.0        | 0.98        |
| SouthWest: Bligh St (SW)        |          |           |             |                  |                       |        |           |                |             |              |             |
| P8                              | Full     | 278       | 36.9        | LOS D            | 0.6                   | 0.6    | 0.91      | 0.91           | 203.5       | 200.0        | 0.98        |
| All Pedestrians                 |          | 1207      | 36.6        | LOS D            | 1.7                   | 1.7    | 0.91      | 0.91           | 203.3       | 200.0        | 0.98        |

Level of Service (LOS) Method: SIDRA Pedestrian LOS Method (Based on Average Delay)

Pedestrian movement LOS values are based on average delay per pedestrian movement.

Intersection LOS value for Pedestrians is based on average delay for all pedestrian movements.

**SIDRA INTERSECTION 9.1 | Copyright © 2000-2022 Akcelik and Associates Pty Ltd | sidrasolutions.com**

Organisation: AECOM AUSTRALIA PTY LTD | Licence: NETWORK / Enterprise Level 1 | Processed: Friday, 14 July 2023 11:34:17 AM

Project: C:\Users\YeungM\AECOM\ANZ-NAC-Sydney Metro-Sydney Metro C&SW Operational Monitoring - General\400\_Technical\432\_Traffic Analysis\SIDRA Modelling\01 Models (Geometry Only)\Block 1\Rev1\_Review\05 SM C&SW\_MPL (Block 1)\_PS.sip9

# MOVEMENT SUMMARY

Site: MPL04 [MPL04 Bent St / Phillip St (Site Folder: Block 1 Model - 2023 PM Peak)]

Output produced by SIDRA INTERSECTION Version: 9.1.1.200

Network: MPL-N1 [MPL Network 1 (Network Folder: Block 1 Network - 2023 PM Peak)]

TCS 242

Site Category: (None)

Signals - EQUISAT (Fixed-Time/SCATS) Coordinated Cycle Time = 90 seconds (Network Site User-Given Phase Times)

| Vehicle Movement Performance |      |           |              |      |               |      |           |             |                  |                   |        |           |                |                     |             |
|------------------------------|------|-----------|--------------|------|---------------|------|-----------|-------------|------------------|-------------------|--------|-----------|----------------|---------------------|-------------|
| Mov ID                       | Turn | Mov Class | Demand Flows |      | Arrival Flows |      | Deg. Satn | Aver. Delay | Level of Service | 95% Back Of Queue |        | Prop. Que | Eff. Stop Rate | Aver. No. of Cycles | Aver. Speed |
|                              |      |           | [ Total HV ] | %    | [ Total HV ]  | %    |           |             |                  | [ Veh. veh        | Dist ] |           |                |                     |             |
|                              |      |           | veh/h        | %    | veh/h         | %    | v/c       | sec         |                  |                   | m      |           |                |                     | km/h        |
| SouthEast: Bent St (SE)      |      |           |              |      |               |      |           |             |                  |                   |        |           |                |                     |             |
| 21                           | L2   | All MCs   | 75           | 7.0  | 75            | 7.0  | 0.074     | 17.0        | LOS B            | 0.7               | 4.9    | 0.26      | 0.50           | 0.26                | 26.1        |
| 22                           | T1   | All MCs   | 300          | 3.5  | 300           | 3.5  | 0.747     | 46.5        | LOS D            | 9.4               | 67.5   | 1.00      | 0.93           | 1.15                | 7.1         |
| 23a                          | R1   | All MCs   | 44           | 7.1  | 44            | 7.1  | *0.747    | 51.9        | LOS D            | 6.4               | 46.9   | 1.00      | 0.93           | 1.19                | 13.3        |
| Approach                     |      |           | 419          | 4.5  | 419           | 4.5  | 0.747     | 41.8        | LOS C            | 9.4               | 67.5   | 0.87      | 0.85           | 1.00                | 9.1         |
| North: Phillip St (N)        |      |           |              |      |               |      |           |             |                  |                   |        |           |                |                     |             |
| 7a                           | L1   | All MCs   | 148          | 0.0  | 148           | 0.0  | *0.196    | 15.9        | LOS B            | 4.0               | 30.6   | 0.58      | 0.64           | 0.58                | 23.7        |
| 9a                           | R1   | All MCs   | 217          | 24.8 | 217           | 24.8 | 0.196     | 9.8         | LOS A            | 4.0               | 30.6   | 0.47      | 0.55           | 0.47                | 24.5        |
| Approach                     |      |           | 365          | 14.7 | 365           | 14.7 | 0.196     | 12.3        | LOS A            | 4.0               | 30.6   | 0.51      | 0.59           | 0.51                | 24.1        |
| NorthWest: Bent St (NW)      |      |           |              |      |               |      |           |             |                  |                   |        |           |                |                     |             |
| 27b                          | L3   | All MCs   | 24           | 0.0  | 24            | 0.0  | 0.489     | 44.7        | LOS D            | 4.2               | 29.7   | 0.88      | 0.71           | 0.88                | 13.9        |
| 28                           | T1   | All MCs   | 149          | 0.0  | 149           | 0.0  | 0.489     | 32.7        | LOS C            | 4.2               | 29.7   | 0.88      | 0.71           | 0.88                | 10.5        |
| 29                           | R2   | All MCs   | 24           | 0.0  | 24            | 0.0  | 0.489     | 44.8        | LOS D            | 3.5               | 24.4   | 0.88      | 0.70           | 0.88                | 4.8         |
| Approach                     |      |           | 198          | 0.0  | 198           | 0.0  | 0.489     | 35.6        | LOS C            | 4.2               | 29.7   | 0.88      | 0.71           | 0.88                | 10.4        |
| SouthWest: Phillip St (SW)   |      |           |              |      |               |      |           |             |                  |                   |        |           |                |                     |             |
| 30                           | L2   | All MCs   | 262          | 17.3 | 262           | 17.3 | 0.247     | 9.7         | LOS A            | 4.5               | 36.4   | 0.42      | 0.63           | 0.42                | 23.5        |
| 30a                          | L1   | All MCs   | 329          | 11.5 | 329           | 11.5 | 0.268     | 7.2         | LOS A            | 5.6               | 42.9   | 0.42      | 0.51           | 0.42                | 31.5        |
| 32                           | R2   | All MCs   | 238          | 2.2  | 238           | 2.2  | *0.438    | 20.2        | LOS B            | 7.3               | 52.2   | 0.85      | 0.71           | 0.85                | 20.2        |
| Approach                     |      |           | 829          | 10.7 | 829           | 10.7 | 0.438     | 11.7        | LOS A            | 7.3               | 52.2   | 0.54      | 0.61           | 0.54                | 25.7        |
| All Vehicles                 |      |           | 1812         | 8.9  | 1812          | 8.9  | 0.747     | 21.4        | LOS B            | 9.4               | 67.5   | 0.65      | 0.67           | 0.68                | 18.5        |

Site Level of Service (LOS) Method: Delay (RTA NSW). Site LOS Method is specified in the Network Data dialog (Override Site Data tab).

Vehicle movement LOS values are based on average delay per movement.

Intersection and Approach LOS values are based on average delay for all vehicle movements.

Delay Model: SIDRA Standard (Control Delay: Geometric Delay is included).

Queue Model: SIDRA queue estimation methods are used for Back of Queue and Queue at Start of Green.

Gap-Acceptance Capacity Formula: SIDRA Standard (Akçelik M3D).

HV (%) values are calculated for All Movement Classes of All Heavy Vehicle Model Designation.

Arrival Flows used in performance calculations are adjusted to include any Initial Queued Demand and Upstream Capacity Constraint effects.

\* Critical Movement (Signal Timing)



| Pedestrian Movement Performance |          |           |             |                  |                       |        |           |                |             |              |             |
|---------------------------------|----------|-----------|-------------|------------------|-----------------------|--------|-----------|----------------|-------------|--------------|-------------|
| Mov ID                          | Crossing | Dem. Flow | Aver. Delay | Level of Service | AVERAGE BACK OF QUEUE |        | Prop. Que | Eff. Stop Rate | Travel Time | Travel Dist. | Aver. Speed |
|                                 |          | ped/h     | sec         |                  | [ Ped                 | Dist ] |           |                | sec         | m            | m/sec       |
|                                 |          |           |             |                  | ped                   | m      |           |                |             |              |             |
| SouthEast: Bent St (SE)         |          |           |             |                  |                       |        |           |                |             |              |             |
| P5                              | Full     | 728       | 34.9        | LOS D            | 1.7                   | 1.7    | 0.89      | 0.89           | 201.5       | 200.0        | 0.99        |
| North: Phillip St (N)           |          |           |             |                  |                       |        |           |                |             |              |             |
| P3                              | Full     | 529       | 36.4        | LOS D            | 1.2                   | 1.2    | 0.91      | 0.91           | 203.0       | 200.0        | 0.99        |
| NorthWest: Bent St (NW)         |          |           |             |                  |                       |        |           |                |             |              |             |
| P7                              | Full     | 373       | 36.1        | LOS D            | 0.9                   | 0.9    | 0.90      | 0.90           | 202.8       | 200.0        | 0.99        |
| SouthWest: Phillip St (SW)      |          |           |             |                  |                       |        |           |                |             |              |             |
| P8                              | Full     | 416       | 34.4        | LOS D            | 0.9                   | 0.9    | 0.88      | 0.88           | 201.1       | 200.0        | 0.99        |
| All Pedestrians                 |          | 2046      | 35.4        | LOS D            | 1.7                   | 1.7    | 0.90      | 0.90           | 202.0       | 200.0        | 0.99        |

Level of Service (LOS) Method: SIDRA Pedestrian LOS Method (Based on Average Delay)

Pedestrian movement LOS values are based on average delay per pedestrian movement.

Intersection LOS value for Pedestrians is based on average delay for all pedestrian movements.

**SIDRA INTERSECTION 9.1 | Copyright © 2000-2022 Akcelik and Associates Pty Ltd | sidrasolutions.com**

Organisation: AECOM AUSTRALIA PTY LTD | Licence: NETWORK / Enterprise Level 1 | Processed: Friday, 14 July 2023 11:34:17 AM

Project: C:\Users\YeungMA\AECOM\ANZ-NAC-Sydney Metro-Sydney Metro C&SW Operational Monitoring - General\400\_Technical\432\_Traffic Analysis\SIDRA Modelling\01 Models (Geometry Only)\Block 1\Rev1\_Review\05 SM C&SW\_MPL (Block 1)\_PS.sip9

# MOVEMENT SUMMARY

 Site: MPL05 [MPL05 Pedestrian Mid-block Crossing at Castlereagh St (Site Folder: Block 1 Model - 2023 PM Peak)]

Output produced by SIDRA INTERSECTION Version: 9.1.1.200

TCS 245

Site Category: (None)

Pedestrian Crossing (Signalised) - EQUISAT (Fixed-Time/SCATS) Isolated Cycle Time = 44 seconds (Site User-Given Phase Times)

| Vehicle Movement Performance |      |           |                       |     |                       |     |           |             |                  |                   |               |           |                |                     |             |
|------------------------------|------|-----------|-----------------------|-----|-----------------------|-----|-----------|-------------|------------------|-------------------|---------------|-----------|----------------|---------------------|-------------|
| Mov ID                       | Turn | Mov Class | Demand Flows          |     | Arrival Flows         |     | Deg. Satn | Aver. Delay | Level of Service | 95% Back Of Queue |               | Prop. Que | Eff. Stop Rate | Aver. No. of Cycles | Aver. Speed |
|                              |      |           | [ Total HV ]<br>veh/h | %   | [ Total HV ]<br>veh/h | %   |           |             |                  | [ Veh. ]<br>veh   | [ Dist ]<br>m |           |                |                     |             |
| North: Castlereagh St (N)    |      |           |                       |     |                       |     |           |             |                  |                   |               |           |                |                     |             |
| 8                            | T1   | All MCs   | 416                   | 9.4 | 416                   | 9.4 | * 0.557   | 12.3        | LOS A            | 6.9               | 49.0          | 0.84      | 0.71           | 0.84                | 26.5        |
| Approach                     |      |           | 416                   | 9.4 | 416                   | 9.4 | 0.557     | 12.3        | LOS A            | 6.9               | 49.0          | 0.84      | 0.71           | 0.84                | 26.5        |
| All Vehicles                 |      |           | 416                   | 9.4 | 416                   | 9.4 | 0.557     | 12.3        | LOS A            | 6.9               | 49.0          | 0.84      | 0.71           | 0.84                | 26.5        |

Site Level of Service (LOS) Method: Delay (RTA NSW). Site LOS Method is specified in the Parameter Settings dialog (Options tab).

Vehicle movement LOS values are based on average delay per movement.

Intersection and Approach LOS values are based on average delay for all vehicle movements.

Delay Model: SIDRA Standard (Control Delay: Geometric Delay is included).

Queue Model: SIDRA queue estimation methods are used for Back of Queue and Queue at Start of Green.

Gap-Acceptance Capacity Formula: SIDRA Standard (Akçelik M3D).

HV (%) values are calculated for All Movement Classes of All Heavy Vehicle Model Designation.

Arrival Flows used in performance calculations are adjusted to include any Initial Queued Demand and Upstream Capacity Constraint effects.

\* Critical Movement (Signal Timing)

| Pedestrian Movement Performance |          |            |           |             |                  |                       |        |           |                |             |              |             |
|---------------------------------|----------|------------|-----------|-------------|------------------|-----------------------|--------|-----------|----------------|-------------|--------------|-------------|
| Mov ID                          | Crossing | Input Vol. | Dem. Flow | Aver. Delay | Level of Service | AVERAGE BACK OF QUEUE |        | Prop. Que | Eff. Stop Rate | Travel Time | Travel Dist. | Aver. Speed |
|                                 |          | ped/h      | ped/h     | sec         |                  | [ Ped                 | Dist ] |           |                | sec         | m            | m/sec       |
|                                 |          |            |           |             |                  | ped                   | m      |           |                |             |              |             |
| South: Castlereagh St (S)       |          |            |           |             |                  |                       |        |           |                |             |              |             |
| P1                              | Full     | 2706       | 2848      | 15.8        | LOS B            | 3.2                   | 3.2    | 0.90      | 0.90           | 182.5       | 200.0        | 1.10        |
| All                             |          | 2706       | 2848      | 15.8        | LOS B            | 3.2                   | 3.2    | 0.90      | 0.90           | 182.5       | 200.0        | 1.10        |
| Pedestrians                     |          |            |           |             |                  |                       |        |           |                |             |              |             |

Level of Service (LOS) Method: SIDRA Pedestrian LOS Method (Based on Average Delay)

Pedestrian movement LOS values are based on average delay per pedestrian movement.

Intersection LOS value for Pedestrians is based on average delay for all pedestrian movements.

**SIDRA INTERSECTION 9.1 | Copyright © 2000-2022 Akcelik and Associates Pty Ltd | sidrasolutions.com**

Organisation: AECOM AUSTRALIA PTY LTD | Licence: NETWORK / Enterprise Level 1 | Processed: Friday, 14 July 2023 11:33:59 AM

Project: C:\Users\Yeung\MAECOMANZ-NAC-Sydney Metro-Sydney Metro C&SW Operational Monitoring - General\400\_Technical\432\_Traffic Analysis\SIDRA Modelling\01 Models (Geometry Only)\Block 1\Rev1\Review\05 SM C&SW\_MPL (Block 1)\_PS.sip9

# MOVEMENT SUMMARY

 **Site: MPL06 [MPL06 Pedestrian Mid-block Crossing at Elizabeth St (Site Folder: Block 1 Model - 2023 PM Peak)]**

**Output produced by SIDRA INTERSECTION Version: 9.1.1.200**

TCS 287

Site Category: (None)

Pedestrian Crossing (Signalised) - EQUISAT (Fixed-Time/SCATS) Isolated Cycle Time = 91 seconds (Site User-Given Phase Times)

| Vehicle Movement Performance |      |           |                       |      |                       |      |           |             |                  |                   |               |           |                |                     |             |
|------------------------------|------|-----------|-----------------------|------|-----------------------|------|-----------|-------------|------------------|-------------------|---------------|-----------|----------------|---------------------|-------------|
| Mov ID                       | Turn | Mov Class | Demand Flows          |      | Arrival Flows         |      | Deg. Satn | Aver. Delay | Level of Service | 95% Back Of Queue |               | Prop. Que | Eff. Stop Rate | Aver. No. of Cycles | Aver. Speed |
|                              |      |           | [ Total HV ]<br>veh/h | %    | [ Total HV ]<br>veh/h | %    |           |             |                  | [ Veh. ]<br>veh   | [ Dist ]<br>m |           |                |                     |             |
| South: Elizabeth St (S)      |      |           |                       |      |                       |      |           |             |                  |                   |               |           |                |                     |             |
| 2                            | T1   | All MCs   | 1025                  | 9.8  | 1025                  | 9.8  | * 0.434   | 11.0        | LOSA             | 10.8              | 81.6          | 0.51      | 0.45           | 0.51                | 30.0        |
| Approach                     |      |           | 1025                  | 9.8  | 1025                  | 9.8  | 0.434     | 8.8         | LOSA             | 10.8              | 81.6          | 0.51      | 0.45           | 0.51                | 30.0        |
| North: Elizabeth St (N)      |      |           |                       |      |                       |      |           |             |                  |                   |               |           |                |                     |             |
| 8                            | T1   | All MCs   | 483                   | 21.1 | 483                   | 21.1 | 0.310     | 7.3         | LOSA             | 7.4               | 52.7          | 0.46      | 0.40           | 0.46                | 30.7        |
| Approach                     |      |           | 483                   | 21.1 | 483                   | 21.1 | 0.310     | 7.3         | LOSA             | 7.4               | 52.7          | 0.46      | 0.40           | 0.46                | 30.7        |
| All Vehicles                 |      |           | 1508                  | 13.4 | 1508                  | 13.4 | 0.434     | 9.8         | LOSA             | 10.8              | 81.6          | 0.50      | 0.44           | 0.50                | 30.2        |

Site Level of Service (LOS) Method: Delay (RTA NSW). Site LOS Method is specified in the Parameter Settings dialog (Options tab).

Vehicle movement LOS values are based on average delay per movement.

Intersection and Approach LOS values are based on average delay for all vehicle movements.

Delay Model: SIDRA Standard (Control Delay: Geometric Delay is included).

Queue Model: SIDRA queue estimation methods are used for Back of Queue and Queue at Start of Green.

Gap-Acceptance Capacity Formula: SIDRA Standard (Akçelik M3D).

HV (%) values are calculated for All Movement Classes of All Heavy Vehicle Model Designation.

Arrival Flows used in performance calculations are adjusted to include any Initial Queued Demand and Upstream Capacity Constraint effects.

\* Critical Movement (Signal Timing)

| Pedestrian Movement Performance |          |            |           |             |                  |                       |        |           |                |             |              |             |
|---------------------------------|----------|------------|-----------|-------------|------------------|-----------------------|--------|-----------|----------------|-------------|--------------|-------------|
| Mov ID                          | Crossing | Input Vol. | Dem. Flow | Aver. Delay | Level of Service | AVERAGE BACK OF QUEUE |        | Prop. Que | Eff. Stop Rate | Travel Time | Travel Dist. | Aver. Speed |
|                                 |          | ped/h      | ped/h     | sec         |                  | [ Ped                 | Dist ] |           |                | sec         | m            | m/sec       |
|                                 |          |            |           |             |                  | ped                   | m      |           |                |             |              |             |
| South: Elizabeth St (S)         |          |            |           |             |                  |                       |        |           |                |             |              |             |
| P1                              | Full     | 4943       | 5203      | 46.0        | LOS E            | 15.3                  | 15.3   | 1.14      | 1.14           | 212.7       | 200.0        | 0.94        |
| All                             |          | 4943       | 5203      | 46.0        | LOS E            | 15.3                  | 15.3   | 1.14      | 1.14           | 212.7       | 200.0        | 0.94        |
| Pedestrians                     |          |            |           |             |                  |                       |        |           |                |             |              |             |

Level of Service (LOS) Method: SIDRA Pedestrian LOS Method (Based on Average Delay)

Pedestrian movement LOS values are based on average delay per pedestrian movement.

Intersection LOS value for Pedestrians is based on average delay for all pedestrian movements.

**SIDRA INTERSECTION 9.1 | Copyright © 2000-2022 Akcelik and Associates Pty Ltd | sidrasolutions.com**

Organisation: AECOM AUSTRALIA PTY LTD | Licence: NETWORK / Enterprise Level 1 | Processed: Friday, 14 July 2023 11:33:59 AM

Project: C:\Users\YeungMAE\COMANZ-NAC-Sydney Metro-Sydney Metro C&SW Operational Monitoring - General\400\_Technical\432\_Traffic Analysis\SIDRA Modelling\01 Models (Geometry Only)\Block 1\Rev1\_Review\05 SM C&SW\_MPL (Block 1)\_PS.sip9

# MOVEMENT SUMMARY

Site: MPL01 [MPL01 Hunter St / Castlereagh St / Bligh St (Site Folder: Block 1 Model - 2023 Weekend Peak)]

Output produced by SIDRA INTERSECTION Version: 9.1.1.200

Network: MPL-N1 [MPL Network 1 (Network Folder: Block 1 Network - 2023 Weekend Peak)]

TCS 244

Site Category: (None)

Signals - EQUISAT (Fixed-Time/SCATS) Coordinated Cycle Time = 65 seconds (Network Site User-Given Phase Times)

| Vehicle Movement Performance |      |           |              |              |               |          |           |             |                  |                   |      |           |                |                     |             |
|------------------------------|------|-----------|--------------|--------------|---------------|----------|-----------|-------------|------------------|-------------------|------|-----------|----------------|---------------------|-------------|
| Mov ID                       | Turn | Mov Class | Demand Flows |              | Arrival Flows |          | Deg. Satn | Aver. Delay | Level of Service | 95% Back Of Queue |      | Prop. Que | Eff. Stop Rate | Aver. No. of Cycles | Aver. Speed |
|                              |      |           | [ Total HV ] | [ Total HV ] | [ Veh. veh ]  | [ Dist ] |           |             |                  | v/c               | sec  |           |                |                     |             |
| East: Hunter St (E)          |      |           |              |              |               |          |           |             |                  |                   |      |           |                |                     |             |
| 4                            | L2   | All MCs   | 81           | 2.6          | 81            | 2.6      | 0.108     | 15.7        | LOS B            | 1.3               | 9.3  | 0.53      | 0.63           | 0.53                | 21.8        |
| 6a                           | R1   | All MCs   | 209          | 1.0          | 209           | 1.0      | *0.258    | 13.3        | LOS A            | 3.4               | 24.3 | 0.55      | 0.58           | 0.55                | 22.7        |
| Approach                     |      |           | 291          | 1.4          | 291           | 1.4      | 0.258     | 13.9        | LOS A            | 3.4               | 24.3 | 0.54      | 0.60           | 0.54                | 22.4        |
| North: Bligh St (N)          |      |           |              |              |               |          |           |             |                  |                   |      |           |                |                     |             |
| 7                            | L2   | All MCs   | 66           | 33.3         | 66            | 33.3     | *0.263    | 29.2        | LOS C            | 1.9               | 14.5 | 0.89      | 0.74           | 0.89                | 14.6        |
| 8                            | T1   | All MCs   | 37           | 8.6          | 37            | 8.6      | 0.055     | 21.7        | LOS B            | 0.6               | 3.3  | 0.83      | 0.61           | 0.83                | 22.4        |
| 9b                           | R3   | All MCs   | 6            | 0.0          | 6             | 0.0      | 0.055     | 28.6        | LOS C            | 0.5               | 3.2  | 0.83      | 0.63           | 0.83                | 20.3        |
| Approach                     |      |           | 109          | 23.1         | 109           | 23.1     | 0.263     | 26.6        | LOS B            | 1.9               | 14.5 | 0.86      | 0.69           | 0.86                | 17.8        |
| NorthWest: Hunter St (NW)    |      |           |              |              |               |          |           |             |                  |                   |      |           |                |                     |             |
| 27a                          | L1   | All MCs   | 192          | 6.6          | 192           | 6.6      | 0.127     | 9.6         | LOS A            | 1.9               | 14.0 | 0.50      | 0.58           | 0.50                | 20.9        |
| 29a                          | R1   | All MCs   | 43           | 0.0          | 43            | 0.0      | *0.127    | 10.7        | LOS A            | 1.7               | 12.5 | 0.53      | 0.58           | 0.53                | 26.5        |
| Approach                     |      |           | 235          | 5.4          | 235           | 5.4      | 0.127     | 9.8         | LOS A            | 1.9               | 14.0 | 0.51      | 0.58           | 0.51                | 22.4        |
| All Vehicles                 |      |           | 635          | 6.6          | 635           | 6.6      | 0.263     | 14.6        | LOS B            | 3.4               | 24.3 | 0.58      | 0.61           | 0.58                | 21.1        |

Site Level of Service (LOS) Method: Delay (RTA NSW). Site LOS Method is specified in the Network Data dialog (Override Site Data tab).

Vehicle movement LOS values are based on average delay per movement.

Intersection and Approach LOS values are based on average delay for all vehicle movements.

Delay Model: SIDRA Standard (Control Delay: Geometric Delay is included).

Queue Model: SIDRA queue estimation methods are used for Back of Queue and Queue at Start of Green.

Gap-Acceptance Capacity Formula: SIDRA Standard (Akçelik M3D).

HV (%) values are calculated for All Movement Classes of All Heavy Vehicle Model Designation.

Arrival Flows used in performance calculations are adjusted to include any Initial Queued Demand and Upstream Capacity Constraint effects.

\* Critical Movement (Signal Timing)

| Pedestrian Movement Performance |          |           |             |                  |                       |        |           |                |             |              |             |
|---------------------------------|----------|-----------|-------------|------------------|-----------------------|--------|-----------|----------------|-------------|--------------|-------------|
| Mov ID                          | Crossing | Dem. Flow | Aver. Delay | Level of Service | AVERAGE BACK OF QUEUE |        | Prop. Que | Eff. Stop Rate | Travel Time | Travel Dist. | Aver. Speed |
|                                 |          | ped/h     | sec         |                  | [ Ped                 | Dist ] |           |                | sec         | m            | m/sec       |
|                                 |          |           |             |                  | ped                   | m      |           |                |             |              |             |
| South: Castlereagh St (S)       |          |           |             |                  |                       |        |           |                |             |              |             |
| P1                              | Full     | 151       | 26.0        | LOS C            | 0.2                   | 0.2    | 0.90      | 0.90           | 192.7       | 200.0        | 1.04        |
| East: Hunter St (E)             |          |           |             |                  |                       |        |           |                |             |              |             |
| P2                              | Full     | 93        | 22.5        | LOS C            | 0.1                   | 0.1    | 0.83      | 0.83           | 189.2       | 200.0        | 1.06        |
| North: Bligh St (N)             |          |           |             |                  |                       |        |           |                |             |              |             |
| P3                              | Full     | 82        | 26.0        | LOS C            | 0.1                   | 0.1    | 0.90      | 0.90           | 192.6       | 200.0        | 1.04        |
| NorthWest: Hunter St (NW)       |          |           |             |                  |                       |        |           |                |             |              |             |
| P7                              | Full     | 96        | 23.4        | LOS C            | 0.2                   | 0.2    | 0.85      | 0.85           | 190.0       | 200.0        | 1.05        |
| All Pedestrians                 |          | 421       | 24.6        | LOS C            | 0.2                   | 0.2    | 0.87      | 0.87           | 191.3       | 200.0        | 1.05        |

Level of Service (LOS) Method: SIDRA Pedestrian LOS Method (Based on Average Delay)  
 Pedestrian movement LOS values are based on average delay per pedestrian movement.  
 Intersection LOS value for Pedestrians is based on average delay for all pedestrian movements.

# MOVEMENT SUMMARY

Site: MPL02 [MPL02 Hunter St / Elizabeth St / Chifley Square  
(Site Folder: Block 1 Model - 2023 Weekend Peak)]

Output produced by SIDRA INTERSECTION Version: 9.1.1.200

Network: MPL-N1 [MPL  
Network 1 (Network Folder:  
Block 1 Network - 2023  
Weekend Peak)]

TCS 302

Site Category: (None)

Signals - EQUISAT (Fixed-Time/SCATS) Coordinated Cycle Time = 65 seconds (Network Site User-Given Phase Times)

| Vehicle Movement Performance   |      |           |              |      |               |      |           |             |                  |                   |            |           |                |                     |             |
|--------------------------------|------|-----------|--------------|------|---------------|------|-----------|-------------|------------------|-------------------|------------|-----------|----------------|---------------------|-------------|
| Mov ID                         | Turn | Mov Class | Demand Flows |      | Arrival Flows |      | Deg. Satn | Aver. Delay | Level of Service | 95% Back Of Queue |            | Prop. Que | Eff. Stop Rate | Aver. No. of Cycles | Aver. Speed |
|                                |      |           | [ Total HV ] | %    | [ Total HV ]  | %    |           |             |                  | [ Veh. veh        | [ Dist ] m |           |                |                     |             |
| South: Elizabeth St (S)        |      |           |              |      |               |      |           |             |                  |                   |            |           |                |                     |             |
| 1                              | L2   | All MCs   | 138          | 1.5  | 138           | 1.5  | 0.153     | 13.2        | LOS A            | 2.4               | 12.2       | 0.58      | 0.66           | 0.58                | 20.0        |
| 3a                             | R1   | All MCs   | 440          | 17.0 | 440           | 17.0 | 0.679     | 19.8        | LOS B            | 11.9              | 95.8       | 0.88      | 0.81           | 0.90                | 16.4        |
| 3                              | R2   | All MCs   | 134          | 2.4  | 134           | 2.4  | *0.359    | 21.7        | LOS B            | 3.3               | 16.8       | 0.88      | 0.76           | 0.88                | 20.6        |
| Approach                       |      |           | 712          | 11.2 | 712           | 11.2 | 0.679     | 18.9        | LOS B            | 11.9              | 95.8       | 0.82      | 0.77           | 0.83                | 18.0        |
| East: Hunter St (E)            |      |           |              |      |               |      |           |             |                  |                   |            |           |                |                     |             |
| 4                              | L2   | All MCs   | 74           | 7.1  | 74            | 7.1  | 0.093     | 14.4        | LOS A            | 1.3               | 7.2        | 0.59      | 0.65           | 0.59                | 24.5        |
| 5                              | T1   | All MCs   | 152          | 1.4  | 152           | 1.4  | *0.247    | 18.0        | LOS B            | 3.6               | 18.3       | 0.78      | 0.63           | 0.78                | 16.9        |
| Approach                       |      |           | 225          | 3.3  | 225           | 3.3  | 0.247     | 16.9        | LOS B            | 3.6               | 18.3       | 0.71      | 0.64           | 0.71                | 19.8        |
| NorthEast: Chifley Square (NE) |      |           |              |      |               |      |           |             |                  |                   |            |           |                |                     |             |
| 24b                            | L3   | All MCs   | 22           | 4.8  | 22            | 4.8  | 0.194     | 30.7        | LOS C            | 1.2               | 12.4       | 0.87      | 0.72           | 0.87                | 18.4        |
| 24a                            | L1   | All MCs   | 135          | 27.3 | 135           | 27.3 | *0.293    | 25.7        | LOS B            | 3.1               | 24.5       | 0.88      | 0.74           | 0.88                | 19.6        |
| Approach                       |      |           | 157          | 24.2 | 157           | 24.2 | 0.293     | 26.4        | LOS B            | 3.1               | 24.5       | 0.88      | 0.73           | 0.88                | 19.4        |
| West: Hunter St (W)            |      |           |              |      |               |      |           |             |                  |                   |            |           |                |                     |             |
| 10a                            | L1   | All MCs   | 108          | 3.9  | 108           | 3.9  | 0.212     | 20.0        | LOS B            | 4.0               | 26.0       | 0.81      | 0.69           | 0.81                | 8.6         |
| 11                             | T1   | All MCs   | 79           | 1.3  | 79            | 1.3  | 0.212     | 13.1        | LOS A            | 4.0               | 26.0       | 0.82      | 0.70           | 0.82                | 19.1        |
| 12                             | R2   | All MCs   | 66           | 46.0 | 66            | 46.0 | *0.212    | 18.5        | LOS B            | 2.0               | 15.8       | 0.83      | 0.72           | 0.83                | 19.7        |
| Approach                       |      |           | 254          | 14.1 | 254           | 14.1 | 0.212     | 17.5        | LOS B            | 4.0               | 26.0       | 0.82      | 0.70           | 0.82                | 15.8        |
| All Vehicles                   |      |           | 1347         | 12.0 | 1347          | 12.0 | 0.679     | 19.1        | LOS B            | 11.9              | 95.8       | 0.81      | 0.73           | 0.82                | 18.2        |

Site Level of Service (LOS) Method: Delay (RTA NSW). Site LOS Method is specified in the Network Data dialog (Override Site Data tab).

Vehicle movement LOS values are based on average delay per movement.

Intersection and Approach LOS values are based on average delay for all vehicle movements.

Delay Model: SIDRA Standard (Control Delay: Geometric Delay is included).

Queue Model: SIDRA queue estimation methods are used for Back of Queue and Queue at Start of Green.

Gap-Acceptance Capacity Formula: SIDRA Standard (Akçelik M3D).

HV (%) values are calculated for All Movement Classes of All Heavy Vehicle Model Designation.

Arrival Flows used in performance calculations are adjusted to include any Initial Queued Demand and Upstream Capacity Constraint effects.

\* Critical Movement (Signal Timing)



| Pedestrian Movement Performance |          |           |             |                  |                       |        |           |                |             |              |             |
|---------------------------------|----------|-----------|-------------|------------------|-----------------------|--------|-----------|----------------|-------------|--------------|-------------|
| Mov ID                          | Crossing | Dem. Flow | Aver. Delay | Level of Service | AVERAGE BACK OF QUEUE |        | Prop. Que | Eff. Stop Rate | Travel Time | Travel Dist. | Aver. Speed |
|                                 |          | ped/h     | sec         |                  | [ Ped                 | Dist ] |           |                | sec         | m            | m/sec       |
|                                 |          |           |             |                  | ped                   | m      |           |                |             |              |             |
| South: Elizabeth St (S)         |          |           |             |                  |                       |        |           |                |             |              |             |
| P1                              | Full     | 53        | 20.1        | LOS C            | 0.1                   | 0.1    | 0.79      | 0.79           | 186.7       | 200.0        | 1.07        |
| East: Hunter St (E)             |          |           |             |                  |                       |        |           |                |             |              |             |
| P2                              | Full     | 120       | 25.1        | LOS C            | 0.2                   | 0.2    | 0.88      | 0.88           | 191.8       | 200.0        | 1.04        |
| NorthEast: Chifley Square (NE)  |          |           |             |                  |                       |        |           |                |             |              |             |
| P6                              | Full     | 158       | 20.1        | LOS C            | 0.2                   | 0.2    | 0.79      | 0.79           | 186.8       | 200.0        | 1.07        |
| West: Hunter St (W)             |          |           |             |                  |                       |        |           |                |             |              |             |
| P4                              | Full     | 112       | 23.4        | LOS C            | 0.2                   | 0.2    | 0.85      | 0.85           | 190.0       | 200.0        | 1.05        |
| All Pedestrians                 |          | 442       | 22.3        | LOS C            | 0.2                   | 0.2    | 0.83      | 0.83           | 189.0       | 200.0        | 1.06        |

Level of Service (LOS) Method: SIDRA Pedestrian LOS Method (Based on Average Delay)

Pedestrian movement LOS values are based on average delay per pedestrian movement.

Intersection LOS value for Pedestrians is based on average delay for all pedestrian movements.

**SIDRA INTERSECTION 9.1 | Copyright © 2000-2022 Akcelik and Associates Pty Ltd | sidrasolutions.com**

Organisation: AECOM AUSTRALIA PTY LTD | Licence: NETWORK / Enterprise Level 1 | Processed: Friday, 14 July 2023 11:34:19 AM

Project: C:\Users\YeungMA\AECOM\ANZ-NAC-Sydney Metro-Sydney Metro C&SW Operational Monitoring - General\400\_Technical\432\_Traffic Analysis\SIDRA Modelling\01 Models (Geometry Only)\Block 1\Rev1\_Review\05 SM C&SW\_MPL (Block 1)\_PS.sip9

# MOVEMENT SUMMARY

Site: MPL03 [MPL03 Bent St / Bligh St (Site Folder: Block 1 Model - 2023 Weekend Peak)]

Output produced by SIDRA INTERSECTION Version: 9.1.1.200

Network: MPL-N1 [MPL Network 1 (Network Folder: Block 1 Network - 2023 Weekend Peak)]

TCS 1412

Site Category: (None)

Signals - EQUISAT (Fixed-Time/SCATS) Coordinated Cycle Time = 65 seconds (Network Site User-Given Phase Times)

| Vehicle Movement Performance |      |           |              |      |               |      |           |             |                  |                   |        |           |                |                     |             |
|------------------------------|------|-----------|--------------|------|---------------|------|-----------|-------------|------------------|-------------------|--------|-----------|----------------|---------------------|-------------|
| Mov ID                       | Turn | Mov Class | Demand Flows |      | Arrival Flows |      | Deg. Satn | Aver. Delay | Level of Service | 95% Back Of Queue |        | Prop. Que | Eff. Stop Rate | Aver. No. of Cycles | Aver. Speed |
|                              |      |           | [ Total HV ] | %    | [ Total HV ]  | %    |           |             |                  | [ Veh. veh        | Dist ] |           |                |                     |             |
|                              |      |           | veh/h        | %    | veh/h         | %    | v/c       | sec         |                  |                   |        |           |                |                     | km/h        |
| SouthEast: Bent St (SE)      |      |           |              |      |               |      |           |             |                  |                   |        |           |                |                     |             |
| 21                           | L2   | All MCs   | 71           | 28.4 | 71            | 28.4 | 0.085     | 6.2         | LOS A            | 0.4               | 3.6    | 0.19      | 0.51           | 0.19                | 18.2        |
| 22                           | T1   | All MCs   | 402          | 5.0  | 402           | 5.0  | *0.390    | 3.4         | LOS A            | 3.1               | 22.6   | 0.26      | 0.23           | 0.26                | 29.9        |
| Approach                     |      |           | 473          | 8.5  | 473           | 8.5  | 0.390     | 3.8         | LOS A            | 3.1               | 22.6   | 0.25      | 0.27           | 0.25                | 28.2        |
| NorthWest: Bent St (NW)      |      |           |              |      |               |      |           |             |                  |                   |        |           |                |                     |             |
| 28                           | T1   | All MCs   | 160          | 1.3  | 160           | 1.3  | 0.098     | 3.5         | LOS A            | 1.3               | 9.5    | 0.36      | 0.32           | 0.36                | 22.2        |
| 29                           | R2   | All MCs   | 38           | 13.9 | 38            | 13.9 | *0.098    | 8.2         | LOS A            | 0.7               | 5.6    | 0.43      | 0.49           | 0.43                | 18.2        |
| Approach                     |      |           | 198          | 3.7  | 198           | 3.7  | 0.098     | 4.4         | LOS A            | 1.3               | 9.5    | 0.38      | 0.36           | 0.38                | 21.3        |
| All Vehicles                 |      |           | 671          | 7.1  | 671           | 7.1  | 0.390     | 4.0         | LOS A            | 3.1               | 22.6   | 0.29      | 0.29           | 0.29                | 26.4        |

Site Level of Service (LOS) Method: Delay (RTA NSW). Site LOS Method is specified in the Network Data dialog (Override Site Data tab).

Vehicle movement LOS values are based on average delay per movement.

Intersection and Approach LOS values are based on average delay for all vehicle movements.

Delay Model: SIDRA Standard (Control Delay: Geometric Delay is included).

Queue Model: SIDRA queue estimation methods are used for Back of Queue and Queue at Start of Green.

Gap-Acceptance Capacity Formula: SIDRA Standard (Akçelik M3D).

HV (%) values are calculated for All Movement Classes of All Heavy Vehicle Model Designation.

Arrival Flows used in performance calculations are adjusted to include any Initial Queued Demand and Upstream Capacity Constraint effects.

\* Critical Movement (Signal Timing)

| Pedestrian Movement Performance |          |           |             |                  |                       |        |           |                |             |              |             |
|---------------------------------|----------|-----------|-------------|------------------|-----------------------|--------|-----------|----------------|-------------|--------------|-------------|
| Mov ID                          | Crossing | Dem. Flow | Aver. Delay | Level of Service | AVERAGE BACK OF QUEUE |        | Prop. Que | Eff. Stop Rate | Travel Time | Travel Dist. | Aver. Speed |
|                                 |          | ped/h     | sec         |                  | [ Ped                 | Dist ] |           |                | sec         | m            | m/sec       |
|                                 |          |           |             |                  | ped                   | m      |           |                |             |              |             |
| SouthEast: Bent St (SE)         |          |           |             |                  |                       |        |           |                |             |              |             |
| P5                              | Full     | 25        | 23.3        | LOS C            | 0.0                   | 0.0    | 0.85      | 0.85           | 190.0       | 200.0        | 1.05        |
| NorthWest: Bent St (NW)         |          |           |             |                  |                       |        |           |                |             |              |             |
| P7                              | Full     | 104       | 23.4        | LOS C            | 0.2                   | 0.2    | 0.85      | 0.85           | 190.0       | 200.0        | 1.05        |
| SouthWest: Bligh St (SW)        |          |           |             |                  |                       |        |           |                |             |              |             |
| P8                              | Full     | 49        | 24.2        | LOS C            | 0.1                   | 0.1    | 0.86      | 0.86           | 190.8       | 200.0        | 1.05        |
| All Pedestrians                 |          | 179       | 23.6        | LOS C            | 0.2                   | 0.2    | 0.85      | 0.85           | 190.2       | 200.0        | 1.05        |

Level of Service (LOS) Method: SIDRA Pedestrian LOS Method (Based on Average Delay)

Pedestrian movement LOS values are based on average delay per pedestrian movement.

Intersection LOS value for Pedestrians is based on average delay for all pedestrian movements.

**SIDRA INTERSECTION 9.1 | Copyright © 2000-2022 Akcelik and Associates Pty Ltd | sidrasolutions.com**

Organisation: AECOM AUSTRALIA PTY LTD | Licence: NETWORK / Enterprise Level 1 | Processed: Friday, 14 July 2023 11:34:19 AM

Project: C:\Users\YeungM\AECOM\ANZ-NAC-Sydney Metro-Sydney Metro C&SW Operational Monitoring - General\400\_Technical\432\_Traffic Analysis\SIDRA Modelling\01 Models (Geometry Only)\Block 1\Rev1\_Review\05 SM C&SW\_MPL (Block 1)\_PS.sip9

# MOVEMENT SUMMARY

Site: MPL04 [MPL04 Bent St / Phillip St (Site Folder: Block 1 Model - 2023 Weekend Peak)]

Output produced by SIDRA INTERSECTION Version: 9.1.1.200

Network: MPL-N1 [MPL Network 1 (Network Folder: Block 1 Network - 2023 Weekend Peak)]

TCS 242

Site Category: (None)

Signals - EQUISAT (Fixed-Time/SCATS) Coordinated Cycle Time = 65 seconds (Network Site User-Given Phase Times)

| Vehicle Movement Performance |      |           |              |      |               |      |           |             |                  |                   |        |           |                |                     |             |
|------------------------------|------|-----------|--------------|------|---------------|------|-----------|-------------|------------------|-------------------|--------|-----------|----------------|---------------------|-------------|
| Mov ID                       | Turn | Mov Class | Demand Flows |      | Arrival Flows |      | Deg. Satn | Aver. Delay | Level of Service | 95% Back Of Queue |        | Prop. Que | Eff. Stop Rate | Aver. No. of Cycles | Aver. Speed |
|                              |      |           | [ Total HV ] | %    | [ Total HV ]  | %    |           |             |                  | [ Veh. veh        | Dist ] |           |                |                     |             |
|                              |      |           | veh/h        | %    | veh/h         | %    | v/c       | sec         |                  |                   | m      |           |                |                     | km/h        |
| SouthEast: Bent St (SE)      |      |           |              |      |               |      |           |             |                  |                   |        |           |                |                     |             |
| 21                           | L2   | All MCs   | 28           | 7.4  | 28            | 7.4  | 0.023     | 4.2         | LOS A            | 0.1               | 0.9    | 0.18      | 0.46           | 0.18                | 28.4        |
| 22                           | T1   | All MCs   | 319          | 2.6  | 319           | 2.6  | *0.790    | 29.0        | LOS C            | 10.0              | 71.7   | 0.97      | 0.93           | 1.14                | 9.7         |
| 23a                          | R1   | All MCs   | 38           | 5.6  | 38            | 5.6  | 0.790     | 35.7        | LOS C            | 10.0              | 71.7   | 1.00      | 1.00           | 1.22                | 17.2        |
| Approach                     |      |           | 385          | 3.3  | 385           | 3.3  | 0.790     | 27.8        | LOS B            | 10.0              | 71.7   | 0.91      | 0.90           | 1.08                | 11.2        |
| North: Phillip St (N)        |      |           |              |      |               |      |           |             |                  |                   |        |           |                |                     |             |
| 7a                           | L1   | All MCs   | 38           | 2.8  | 38            | 2.8  | 0.104     | 13.8        | LOS A            | 1.4               | 11.1   | 0.58      | 0.60           | 0.58                | 25.6        |
| 9a                           | R1   | All MCs   | 118          | 30.4 | 118           | 30.4 | *0.104    | 11.0        | LOS A            | 1.4               | 11.1   | 0.56      | 0.58           | 0.56                | 23.3        |
| Approach                     |      |           | 156          | 23.6 | 156           | 23.6 | 0.104     | 11.7        | LOS A            | 1.4               | 11.2   | 0.56      | 0.58           | 0.56                | 24.0        |
| NorthWest: Bent St (NW)      |      |           |              |      |               |      |           |             |                  |                   |        |           |                |                     |             |
| 27b                          | L3   | All MCs   | 7            | 0.0  | 7             | 0.0  | 0.229     | 24.0        | LOS B            | 2.2               | 15.6   | 0.75      | 0.60           | 0.75                | 19.2        |
| 28                           | T1   | All MCs   | 147          | 0.7  | 147           | 0.7  | 0.229     | 20.4        | LOS B            | 2.2               | 15.6   | 0.78      | 0.62           | 0.78                | 14.8        |
| 29                           | R2   | All MCs   | 12           | 0.0  | 12            | 0.0  | 0.229     | 31.9        | LOS C            | 1.9               | 13.2   | 0.82      | 0.64           | 0.82                | 7.0         |
| Approach                     |      |           | 166          | 0.6  | 166           | 0.6  | 0.229     | 21.4        | LOS B            | 2.2               | 15.6   | 0.78      | 0.62           | 0.78                | 14.6        |
| SouthWest: Phillip St (SW)   |      |           |              |      |               |      |           |             |                  |                   |        |           |                |                     |             |
| 30                           | L2   | All MCs   | 168          | 19.4 | 168           | 19.4 | 0.183     | 13.3        | LOS A            | 3.4               | 27.7   | 0.67      | 0.60           | 0.67                | 20.7        |
| 30a                          | L1   | All MCs   | 229          | 17.9 | 229           | 17.9 | 0.221     | 10.3        | LOS A            | 4.6               | 37.4   | 0.68      | 0.51           | 0.68                | 29.0        |
| 32                           | R2   | All MCs   | 151          | 3.5  | 151           | 3.5  | *0.238    | 16.1        | LOS B            | 3.5               | 25.6   | 0.96      | 0.61           | 0.96                | 22.3        |
| Approach                     |      |           | 548          | 14.4 | 548           | 14.4 | 0.238     | 12.8        | LOS A            | 4.6               | 37.4   | 0.75      | 0.56           | 0.75                | 25.1        |
| All Vehicles                 |      |           | 1256         | 10.3 | 1256          | 10.3 | 0.790     | 18.4        | LOS B            | 10.0              | 71.7   | 0.78      | 0.68           | 0.83                | 19.0        |

Site Level of Service (LOS) Method: Delay (RTA NSW). Site LOS Method is specified in the Network Data dialog (Override Site Data tab).

Vehicle movement LOS values are based on average delay per movement.

Intersection and Approach LOS values are based on average delay for all vehicle movements.

Delay Model: SIDRA Standard (Control Delay: Geometric Delay is included).

Queue Model: SIDRA queue estimation methods are used for Back of Queue and Queue at Start of Green.

Gap-Acceptance Capacity Formula: SIDRA Standard (Akçelik M3D).

HV (%) values are calculated for All Movement Classes of All Heavy Vehicle Model Designation.

Arrival Flows used in performance calculations are adjusted to include any Initial Queued Demand and Upstream Capacity Constraint effects.

\* Critical Movement (Signal Timing)

| Pedestrian Movement Performance |          |           |             |                  |                       |        |           |                |             |              |             |
|---------------------------------|----------|-----------|-------------|------------------|-----------------------|--------|-----------|----------------|-------------|--------------|-------------|
| Mov ID                          | Crossing | Dem. Flow | Aver. Delay | Level of Service | AVERAGE BACK OF QUEUE |        | Prop. Que | Eff. Stop Rate | Travel Time | Travel Dist. | Aver. Speed |
|                                 |          | ped/h     | sec         |                  | [ Ped                 | Dist ] |           |                | sec         | m            | m/sec       |
|                                 |          |           |             |                  | ped                   | m      |           |                |             |              |             |
| SouthEast: Bent St (SE)         |          |           |             |                  |                       |        |           |                |             |              |             |
| P5                              | Full     | 118       | 21.7        | LOS C            | 0.2                   | 0.2    | 0.82      | 0.82           | 188.4       | 200.0        | 1.06        |
| North: Phillip St (N)           |          |           |             |                  |                       |        |           |                |             |              |             |
| P3                              | Full     | 28        | 23.3        | LOS C            | 0.0                   | 0.0    | 0.85      | 0.85           | 190.0       | 200.0        | 1.05        |
| NorthWest: Bent St (NW)         |          |           |             |                  |                       |        |           |                |             |              |             |
| P7                              | Full     | 83        | 23.4        | LOS C            | 0.1                   | 0.1    | 0.85      | 0.85           | 190.0       | 200.0        | 1.05        |
| SouthWest: Phillip St (SW)      |          |           |             |                  |                       |        |           |                |             |              |             |
| P8                              | Full     | 78        | 21.7        | LOS C            | 0.1                   | 0.1    | 0.82      | 0.82           | 188.3       | 200.0        | 1.06        |
| All Pedestrians                 |          | 307       | 22.3        | LOS C            | 0.2                   | 0.2    | 0.83      | 0.83           | 189.0       | 200.0        | 1.06        |

Level of Service (LOS) Method: SIDRA Pedestrian LOS Method (Based on Average Delay)

Pedestrian movement LOS values are based on average delay per pedestrian movement.

Intersection LOS value for Pedestrians is based on average delay for all pedestrian movements.

**SIDRA INTERSECTION 9.1 | Copyright © 2000-2022 Akcelik and Associates Pty Ltd | sidrasolutions.com**

Organisation: AECOM AUSTRALIA PTY LTD | Licence: NETWORK / Enterprise Level 1 | Processed: Friday, 14 July 2023 11:34:19 AM

Project: C:\Users\YeungMA\AECOM\ANZ-NAC-Sydney Metro-Sydney Metro C&SW Operational Monitoring - General\400\_Technical\432\_Traffic Analysis\SIDRA Modelling\01 Models (Geometry Only)\Block 1\Rev1\_Review\05 SM C&SW\_MPL (Block 1)\_PS.sip9

# MOVEMENT SUMMARY

 **Site: MPL05 [MPL05 Pedestrian Mid-block Crossing at Castlereagh St (Site Folder: Block 1 Model - 2023 Weekend Peak)]**

Output produced by SIDRA INTERSECTION Version: 9.1.1.200

TCS 245

Site Category: (None)

Pedestrian Crossing (Signalised) - EQUISAT (Fixed-Time/SCATS) Isolated Cycle Time = 51 seconds (Site User-Given Phase Times)

| Vehicle Movement Performance |      |           |                       |     |                       |     |           |             |                  |                   |               |           |                |                     |             |
|------------------------------|------|-----------|-----------------------|-----|-----------------------|-----|-----------|-------------|------------------|-------------------|---------------|-----------|----------------|---------------------|-------------|
| Mov ID                       | Turn | Mov Class | Demand Flows          |     | Arrival Flows         |     | Deg. Satn | Aver. Delay | Level of Service | 95% Back Of Queue |               | Prop. Que | Eff. Stop Rate | Aver. No. of Cycles | Aver. Speed |
|                              |      |           | [ Total HV ]<br>veh/h | %   | [ Total HV ]<br>veh/h | %   |           |             |                  | [ Veh. ]<br>veh   | [ Dist ]<br>m |           |                |                     |             |
| North: Castlereagh St (N)    |      |           |                       |     |                       |     |           |             |                  |                   |               |           |                |                     |             |
| 8                            | T1   | All MCs   | 216                   | 5.4 | 216                   | 5.4 | *0.211    | 6.4         | LOSA             | 2.7               | 20.1          | 0.54      | 0.45           | 0.54                | 31.7        |
| Approach                     |      |           | 216                   | 5.4 | 216                   | 5.4 | 0.211     | 6.4         | LOSA             | 2.7               | 20.1          | 0.54      | 0.45           | 0.54                | 31.7        |
| All Vehicles                 |      |           | 216                   | 5.4 | 216                   | 5.4 | 0.211     | 6.4         | LOSA             | 2.7               | 20.1          | 0.54      | 0.45           | 0.54                | 31.7        |

Site Level of Service (LOS) Method: Delay (RTA NSW). Site LOS Method is specified in the Parameter Settings dialog (Options tab).

Vehicle movement LOS values are based on average delay per movement.

Intersection and Approach LOS values are based on average delay for all vehicle movements.

Delay Model: SIDRA Standard (Control Delay: Geometric Delay is included).

Queue Model: SIDRA queue estimation methods are used for Back of Queue and Queue at Start of Green.

Gap-Acceptance Capacity Formula: SIDRA Standard (Akçelik M3D).

HV (%) values are calculated for All Movement Classes of All Heavy Vehicle Model Designation.

Arrival Flows used in performance calculations are adjusted to include any Initial Queued Demand and Upstream Capacity Constraint effects.

\* Critical Movement (Signal Timing)

| Pedestrian Movement Performance |          |       |       |       |                  |                       |        |           |                |             |              |             |       |
|---------------------------------|----------|-------|-------|-------|------------------|-----------------------|--------|-----------|----------------|-------------|--------------|-------------|-------|
| Mov ID                          | Crossing | Input | Dem.  | Aver. | Level of Service | AVERAGE BACK OF QUEUE |        | Prop. Que | Eff. Stop Rate | Travel Time | Travel Dist. | Aver. Speed |       |
|                                 |          | Vol.  | Flow  | Delay |                  | [ Ped                 | Dist ] |           |                |             |              |             |       |
|                                 |          | ped/h | ped/h | sec   |                  |                       | ped    | m         |                |             | sec          | m           | m/sec |
| South: Castlereagh St (S)       |          |       |       |       |                  |                       |        |           |                |             |              |             |       |
| P1                              | Full     | 589   | 620   | 17.8  | LOS B            | 0.8                   | 0.8    | 0.85      | 0.85           | 184.4       | 200.0        | 1.08        |       |
| All                             |          | 589   | 620   | 17.8  | LOS B            | 0.8                   | 0.8    | 0.85      | 0.85           | 184.4       | 200.0        | 1.08        |       |
| Pedestrians                     |          |       |       |       |                  |                       |        |           |                |             |              |             |       |

Level of Service (LOS) Method: SIDRA Pedestrian LOS Method (Based on Average Delay)

Pedestrian movement LOS values are based on average delay per pedestrian movement.

Intersection LOS value for Pedestrians is based on average delay for all pedestrian movements.

---

**SIDRA INTERSECTION 9.1 | Copyright © 2000-2022 Akcelik and Associates Pty Ltd | sidrasolutions.com**

Organisation: AECOM AUSTRALIA PTY LTD | Licence: NETWORK / Enterprise Level 1 | Processed: Friday, 14 July 2023 11:34:02 AM

Project: C:\Users\Yeung\MAECOMANZ-NAC-Sydney Metro-Sydney Metro C&SW Operational Monitoring - General\400\_Technical\432\_Traffic Analysis\SIDRA Modelling\01 Models (Geometry Only)\Block 1\Rev1\_Review\05 SM C&SW\_MPL (Block 1)\_PS.sip9

# MOVEMENT SUMMARY

 **Site: MPL06 [MPL06 Pedestrian Mid-block Crossing at Elizabeth St (Site Folder: Block 1 Model - 2023 Weekend Peak)]**

**Output produced by SIDRA INTERSECTION Version: 9.1.1.200**

TCS 287

Site Category: (None)

Pedestrian Crossing (Signalised) - EQUISAT (Fixed-Time/SCATS) Isolated Cycle Time = 45 seconds (Site User-Given Phase Times)

| Vehicle Movement Performance |      |           |                       |      |                       |      |           |             |                  |                   |               |           |                |                     |             |
|------------------------------|------|-----------|-----------------------|------|-----------------------|------|-----------|-------------|------------------|-------------------|---------------|-----------|----------------|---------------------|-------------|
| Mov ID                       | Turn | Mov Class | Demand Flows          |      | Arrival Flows         |      | Deg. Satn | Aver. Delay | Level of Service | 95% Back Of Queue |               | Prop. Que | Eff. Stop Rate | Aver. No. of Cycles | Aver. Speed |
|                              |      |           | [ Total HV ]<br>veh/h | %    | [ Total HV ]<br>veh/h | %    |           |             |                  | [ Veh. ]<br>veh   | [ Dist ]<br>m |           |                |                     |             |
| South: Elizabeth St (S)      |      |           |                       |      |                       |      |           |             |                  |                   |               |           |                |                     |             |
| 2                            | T1   | All MCs   | 709                   | 11.0 | 709                   | 11.0 | * 0.672   | 20.7        | LOS B            | 7.2               | 55.4          | 0.92      | 0.83           | 1.00                | 23.8        |
| Approach                     |      |           | 709                   | 11.0 | 709                   | 11.0 | 0.672     | 17.5        | LOS B            | 7.2               | 55.4          | 0.92      | 0.83           | 1.00                | 23.8        |
| North: Elizabeth St (N)      |      |           |                       |      |                       |      |           |             |                  |                   |               |           |                |                     |             |
| 8                            | T1   | All MCs   | 274                   | 26.2 | 274                   | 26.2 | 0.389     | 14.3        | LOS A            | 3.9               | 28.0          | 0.83      | 0.68           | 0.83                | 25.2        |
| Approach                     |      |           | 274                   | 26.2 | 274                   | 26.2 | 0.389     | 14.3        | LOS A            | 3.9               | 28.0          | 0.83      | 0.68           | 0.83                | 25.2        |
| All Vehicles                 |      |           | 983                   | 15.2 | 983                   | 15.2 | 0.672     | 18.9        | LOS B            | 7.2               | 55.4          | 0.90      | 0.79           | 0.96                | 24.1        |

Site Level of Service (LOS) Method: Delay (RTA NSW). Site LOS Method is specified in the Parameter Settings dialog (Options tab).

Vehicle movement LOS values are based on average delay per movement.

Intersection and Approach LOS values are based on average delay for all vehicle movements.

Delay Model: SIDRA Standard (Control Delay: Geometric Delay is included).

Queue Model: SIDRA queue estimation methods are used for Back of Queue and Queue at Start of Green.

Gap-Acceptance Capacity Formula: SIDRA Standard (Akçelik M3D).

HV (%) values are calculated for All Movement Classes of All Heavy Vehicle Model Designation.

Arrival Flows used in performance calculations are adjusted to include any Initial Queued Demand and Upstream Capacity Constraint effects.

\* Critical Movement (Signal Timing)



| Pedestrian Movement Performance |          |       |       |       |                  |                       |        |           |                |             |              |             |       |
|---------------------------------|----------|-------|-------|-------|------------------|-----------------------|--------|-----------|----------------|-------------|--------------|-------------|-------|
| Mov ID                          | Crossing | Input | Dem.  | Aver. | Level of Service | AVERAGE BACK OF QUEUE |        | Prop. Que | Eff. Stop Rate | Travel Time | Travel Dist. | Aver. Speed |       |
|                                 |          | Vol.  | Flow  | Delay |                  | [ Ped                 | Dist ] |           |                |             |              |             |       |
|                                 |          | ped/h | ped/h | sec   |                  |                       | ped    | m         |                |             | sec          | m           | m/sec |
| South: Elizabeth St (S)         |          |       |       |       |                  |                       |        |           |                |             |              |             |       |
| P1                              | Full     | 600   | 632   | 14.0  | LOS B            | 0.6                   | 0.6    | 0.80      | 0.80           | 180.6       | 200.0        | 1.11        |       |
| All                             |          | 600   | 632   | 14.0  | LOS B            | 0.6                   | 0.6    | 0.80      | 0.80           | 180.6       | 200.0        | 1.11        |       |
| Pedestrians                     |          |       |       |       |                  |                       |        |           |                |             |              |             |       |

Level of Service (LOS) Method: SIDRA Pedestrian LOS Method (Based on Average Delay)

Pedestrian movement LOS values are based on average delay per pedestrian movement.

Intersection LOS value for Pedestrians is based on average delay for all pedestrian movements.

---

**SIDRA INTERSECTION 9.1 | Copyright © 2000-2022 Akcelik and Associates Pty Ltd | sidrasolutions.com**

Organisation: AECOM AUSTRALIA PTY LTD | Licence: NETWORK / Enterprise Level 1 | Processed: Friday, 14 July 2023 11:34:02 AM

Project: C:\Users\YeungM\AECOM\ANZ-NAC-Sydney Metro-Sydney Metro C&SW Operational Monitoring - General\400\_Technical\432\_Traffic Analysis\SIDRA Modelling\01 Models (Geometry Only)\Block 1\Rev1\Review\05 SM C&SW\_MPL (Block 1)\_PS.sip9

# MOVEMENT SUMMARY

Site: PIT01 [PIT01 Pitt St / Bathurst St (Site Folder: Block 1 Model - 2023 AM Peak)]

Output produced by SIDRA INTERSECTION Version: 9.1.1.200

Network: PIT-N1 [PIT Network 1 (Network Folder: Block 1 Network - 2023 AM Peak)]

TCS 2312

Site Category: (None)

Signals - EQUISAT (Fixed-Time/SCATS) Coordinated Cycle Time = 52 seconds (Network Site User-Given Phase Times)

| Vehicle Movement Performance |      |           |              |     |               |     |           |             |                  |                   |          |           |                |                     |             |
|------------------------------|------|-----------|--------------|-----|---------------|-----|-----------|-------------|------------------|-------------------|----------|-----------|----------------|---------------------|-------------|
| Mov ID                       | Turn | Mov Class | Demand Flows |     | Arrival Flows |     | Deg. Satn | Aver. Delay | Level of Service | 95% Back Of Queue |          | Prop. Que | Eff. Stop Rate | Aver. No. of Cycles | Aver. Speed |
|                              |      |           | [ Total HV ] | %   | [ Total HV ]  | %   |           |             |                  | [ Veh. veh        | Dist ] m |           |                |                     |             |
| South: Pitt St (S)           |      |           |              |     |               |     |           |             |                  |                   |          |           |                |                     |             |
| 2                            | T1   | All MCs   | 271          | 7.0 | 271           | 7.0 | *0.297    | 17.7        | LOS B            | 2.9               | 21.5     | 0.85      | 0.68           | 0.85                | 21.8        |
| 3                            | R2   | All MCs   | 108          | 8.7 | 108           | 8.7 | 0.369     | 25.7        | LOS B            | 2.6               | 19.5     | 0.92      | 0.77           | 0.92                | 17.9        |
| Approach                     |      |           | 379          | 7.5 | 379           | 7.5 | 0.369     | 20.0        | LOS B            | 2.9               | 21.5     | 0.87      | 0.71           | 0.87                | 20.6        |
| West: Bathurst St (W)        |      |           |              |     |               |     |           |             |                  |                   |          |           |                |                     |             |
| 10                           | L2   | All MCs   | 245          | 3.9 | 245           | 3.9 | *0.374    | 16.0        | LOS B            | 4.4               | 31.5     | 0.73      | 0.74           | 0.73                | 14.8        |
| 11                           | T1   | All MCs   | 945          | 4.6 | 945           | 4.6 | 0.338     | 8.3         | LOS A            | 4.9               | 35.7     | 0.62      | 0.53           | 0.62                | 20.5        |
| Approach                     |      |           | 1191         | 4.4 | 1191          | 4.4 | 0.374     | 9.9         | LOS A            | 4.9               | 35.7     | 0.64      | 0.57           | 0.64                | 19.0        |
| All Vehicles                 |      |           | 1569         | 5.2 | 1569          | 5.2 | 0.374     | 12.4        | LOS A            | 4.9               | 35.7     | 0.70      | 0.61           | 0.70                | 19.6        |

Site Level of Service (LOS) Method: Delay (RTA NSW). Site LOS Method is specified in the Network Data dialog (Override Site Data tab).

Vehicle movement LOS values are based on average delay per movement.

Intersection and Approach LOS values are based on average delay for all vehicle movements.

Delay Model: SIDRA Standard (Control Delay: Geometric Delay is included).

Queue Model: SIDRA queue estimation methods are used for Back of Queue and Queue at Start of Green.

Gap-Acceptance Capacity Formula: SIDRA Standard (Akçelik M3D).

HV (%) values are calculated for All Movement Classes of All Heavy Vehicle Model Designation.

Arrival Flows used in performance calculations are adjusted to include any Initial Queued Demand and Upstream Capacity Constraint effects.

\* Critical Movement (Signal Timing)

| Pedestrian Movement Performance |          |           |             |                  |                       |        |           |                |             |              |             |
|---------------------------------|----------|-----------|-------------|------------------|-----------------------|--------|-----------|----------------|-------------|--------------|-------------|
| Mov ID                          | Crossing | Dem. Flow | Aver. Delay | Level of Service | AVERAGE BACK OF QUEUE |        | Prop. Que | Eff. Stop Rate | Travel Time | Travel Dist. | Aver. Speed |
|                                 |          | ped/h     | sec         |                  | [ Ped                 | Dist ] |           |                | sec         | m            | m/sec       |
|                                 |          |           |             |                  | ped                   | m      |           |                |             |              |             |
| South: Pitt St (S)              |          |           |             |                  |                       |        |           |                |             |              |             |
| P1                              | Full     | 752       | 21.0        | LOS C            | 1.0                   | 1.0    | 0.91      | 0.91           | 37.7        | 20.0         | 0.53        |
| East: Bathurst St (E)           |          |           |             |                  |                       |        |           |                |             |              |             |
| P2                              | Full     | 369       | 20.7        | LOS C            | 0.5                   | 0.5    | 0.90      | 0.90           | 37.3        | 20.0         | 0.54        |
| North: Pitt St (N)              |          |           |             |                  |                       |        |           |                |             |              |             |
| P3                              | Full     | 803       | 21.1        | LOS C            | 1.1                   | 1.1    | 0.92      | 0.92           | 37.7        | 20.0         | 0.53        |
| West: Bathurst St (W)           |          |           |             |                  |                       |        |           |                |             |              |             |
| P4                              | Full     | 678       | 18.3        | LOS B            | 0.9                   | 0.9    | 0.85      | 0.85           | 35.0        | 20.0         | 0.57        |
| All Pedestrians                 |          | 2602      | 20.3        | LOS C            | 1.1                   | 1.1    | 0.90      | 0.90           | 36.9        | 20.0         | 0.54        |

Level of Service (LOS) Method: SIDRA Pedestrian LOS Method (Based on Average Delay)  
 Pedestrian movement LOS values are based on average delay per pedestrian movement.  
 Intersection LOS value for Pedestrians is based on average delay for all pedestrian movements.

# MOVEMENT SUMMARY

Site: PIT02 [PIT02 Castlereagh St / Bathurst St (Site Folder: Block 1 Model - 2023 AM Peak)]

Output produced by SIDRA INTERSECTION Version: 9.1.1.200

Network: PIT-N1 [PIT Network 1 (Network Folder: Block 1 Network - 2023 AM Peak)]

TCS 2281

Site Category: (None)

Signals - EQUISAT (Fixed-Time/SCATS) Coordinated Cycle Time = 52 seconds (Network Site User-Given Phase Times)

| Vehicle Movement Performance |      |           |              |      |               |      |           |             |                  |                   |        |           |                |                     |             |
|------------------------------|------|-----------|--------------|------|---------------|------|-----------|-------------|------------------|-------------------|--------|-----------|----------------|---------------------|-------------|
| Mov ID                       | Turn | Mov Class | Demand Flows |      | Arrival Flows |      | Deg. Satn | Aver. Delay | Level of Service | 95% Back Of Queue |        | Prop. Que | Eff. Stop Rate | Aver. No. of Cycles | Aver. Speed |
|                              |      |           | [ Total HV ] | %    | [ Total HV ]  | %    |           |             |                  | [ Veh. veh        | Dist ] |           |                |                     |             |
|                              |      |           | veh/h        | %    | veh/h         | %    | v/c       | sec         |                  |                   | m      |           |                |                     | km/h        |
| North: Castlereagh St (N)    |      |           |              |      |               |      |           |             |                  |                   |        |           |                |                     |             |
| 7                            | L2   | All MCs   | 85           | 8.6  | 85            | 8.6  | 0.326     | 26.0        | LOS B            | 2.1               | 15.5   | 0.93      | 0.75           | 0.93                | 15.0        |
| 8                            | T1   | All MCs   | 262          | 10.0 | 262           | 10.0 | *0.256    | 15.8        | LOS B            | 2.6               | 20.1   | 0.81      | 0.65           | 0.81                | 27.0        |
| Approach                     |      |           | 347          | 9.7  | 347           | 9.7  | 0.326     | 18.3        | LOS B            | 2.6               | 20.1   | 0.84      | 0.67           | 0.84                | 24.3        |
| West: Bathurst St (W)        |      |           |              |      |               |      |           |             |                  |                   |        |           |                |                     |             |
| 11                           | T1   | All MCs   | 888          | 4.5  | 888           | 4.5  | 0.319     | 3.4         | LOS A            | 3.2               | 23.1   | 0.30      | 0.26           | 0.30                | 30.1        |
| 12                           | R2   | All MCs   | 156          | 7.4  | 156           | 7.4  | *0.319    | 13.3        | LOS A            | 2.5               | 18.8   | 0.55      | 0.66           | 0.55                | 26.7        |
| Approach                     |      |           | 1044         | 4.9  | 1044          | 4.9  | 0.319     | 4.9         | LOS A            | 3.2               | 23.1   | 0.33      | 0.32           | 0.33                | 29.0        |
| All Vehicles                 |      |           | 1392         | 6.1  | 1392          | 6.1  | 0.326     | 8.2         | LOS A            | 3.2               | 23.1   | 0.46      | 0.41           | 0.46                | 26.9        |

Site Level of Service (LOS) Method: Delay (RTA NSW). Site LOS Method is specified in the Network Data dialog (Override Site Data tab).

Vehicle movement LOS values are based on average delay per movement.

Intersection and Approach LOS values are based on average delay for all vehicle movements.

Delay Model: SIDRA Standard (Control Delay: Geometric Delay is included).

Queue Model: SIDRA queue estimation methods are used for Back of Queue and Queue at Start of Green.

Gap-Acceptance Capacity Formula: SIDRA Standard (Akçelik M3D).

HV (%) values are calculated for All Movement Classes of All Heavy Vehicle Model Designation.

Arrival Flows used in performance calculations are adjusted to include any Initial Queued Demand and Upstream Capacity Constraint effects.

\* Critical Movement (Signal Timing)

| Pedestrian Movement Performance |          |           |             |                  |                       |        |           |                |             |              |             |
|---------------------------------|----------|-----------|-------------|------------------|-----------------------|--------|-----------|----------------|-------------|--------------|-------------|
| Mov ID                          | Crossing | Dem. Flow | Aver. Delay | Level of Service | AVERAGE BACK OF QUEUE |        | Prop. Que | Eff. Stop Rate | Travel Time | Travel Dist. | Aver. Speed |
|                                 |          | ped/h     | sec         |                  | [ Ped                 | Dist ] |           |                | sec         | m            | m/sec       |
|                                 |          |           |             |                  | ped                   | m      |           |                |             |              |             |
| South: Castlereagh St (S)       |          |           |             |                  |                       |        |           |                |             |              |             |
| P1                              | Full     | 746       | 16.7        | LOS B            | 0.9                   | 0.9    | 0.81      | 0.81           | 33.3        | 20.0         | 0.60        |
| East: Bathurst St (E)           |          |           |             |                  |                       |        |           |                |             |              |             |
| P2                              | Full     | 371       | 15.6        | LOS B            | 0.4                   | 0.4    | 0.78      | 0.78           | 32.3        | 20.0         | 0.62        |
| North: Castlereagh St (N)       |          |           |             |                  |                       |        |           |                |             |              |             |
| P3                              | Full     | 424       | 19.8        | LOS B            | 0.6                   | 0.6    | 0.88      | 0.88           | 36.5        | 20.0         | 0.55        |
| West: Bathurst St (W)           |          |           |             |                  |                       |        |           |                |             |              |             |
| P4                              | Full     | 347       | 16.4        | LOS B            | 0.4                   | 0.4    | 0.80      | 0.80           | 33.1        | 20.0         | 0.60        |
| All Pedestrians                 |          | 1888      | 17.1        | LOS B            | 0.9                   | 0.9    | 0.82      | 0.82           | 33.8        | 20.0         | 0.59        |

Level of Service (LOS) Method: SIDRA Pedestrian LOS Method (Based on Average Delay)

Pedestrian movement LOS values are based on average delay per pedestrian movement.

Intersection LOS value for Pedestrians is based on average delay for all pedestrian movements.

**SIDRA INTERSECTION 9.1 | Copyright © 2000-2022 Akcelik and Associates Pty Ltd | sidrasolutions.com**

Organisation: AECOM AUSTRALIA PTY LTD | Licence: NETWORK / Enterprise Level 1 | Processed: Friday, 14 July 2023 11:24:47 AM

Project: C:\Users\YeungMAECOMANZ-NAC-Sydney Metro-Sydney Metro C&SW Operational Monitoring - General\400\_Technical\432\_Traffic Analysis\SIDRA Modelling\01 Models (Geometry Only)\Block 1\Rev1\_Review\06 SM C&SW\_PIT (Block 1)\_PS.sip9

# MOVEMENT SUMMARY

Site: PIT03 [PIT03 Park St / Castlereagh St (Site Folder: Block 1 Model - 2023 AM Peak)]

Output produced by SIDRA INTERSECTION Version: 9.1.1.200

Network: PIT-N1 [PIT Network 1 (Network Folder: Block 1 Network - 2023 AM Peak)]

TCS 250

Site Category: (None)

Signals - EQUISAT (Fixed-Time/SCATS) Isolated Cycle Time = 91 seconds (Site User-Given Phase Times)

| Vehicle Movement Performance |      |           |                       |      |                       |      |           |             |                  |                   |               |           |                |                     |                  |
|------------------------------|------|-----------|-----------------------|------|-----------------------|------|-----------|-------------|------------------|-------------------|---------------|-----------|----------------|---------------------|------------------|
| Mov ID                       | Turn | Mov Class | Demand Flows          |      | Arrival Flows         |      | Deg. Satn | Aver. Delay | Level of Service | 95% Back Of Queue |               | Prop. Que | Eff. Stop Rate | Aver. No. of Cycles | Aver. Speed km/h |
|                              |      |           | [ Total HV ]<br>veh/h | %    | [ Total HV ]<br>veh/h | %    |           |             |                  | [ Veh. veh        | [ Dist ]<br>m |           |                |                     |                  |
| East: Park St (E)            |      |           |                       |      |                       |      |           |             |                  |                   |               |           |                |                     |                  |
| 4                            | L2   | All MCs   | 97                    | 4.3  | 97                    | 4.3  | 0.108     | 15.5        | LOS B            | 2.2               | 16.1          | 0.55      | 0.64           | 0.55                | 9.1              |
| 5                            | T1   | All MCs   | 397                   | 17.8 | 397                   | 17.8 | *0.349    | 10.9        | LOS A            | 8.2               | 60.7          | 0.56      | 0.48           | 0.56                | 11.9             |
| Approach                     |      |           | 494                   | 15.1 | 494                   | 15.1 | 0.349     | 11.8        | LOS A            | 8.2               | 60.7          | 0.56      | 0.52           | 0.56                | 11.2             |
| North: Castlereagh St (N)    |      |           |                       |      |                       |      |           |             |                  |                   |               |           |                |                     |                  |
| 7                            | L2   | All MCs   | 143                   | 8.8  | 143                   | 8.8  | 0.320     | 32.9        | LOS C            | 5.2               | 39.1          | 0.85      | 0.76           | 0.85                | 17.7             |
| 8                            | T1   | All MCs   | 226                   | 8.4  | 226                   | 8.4  | *0.567    | 34.9        | LOS C            | 9.1               | 68.3          | 0.94      | 0.78           | 0.94                | 16.5             |
| 9                            | R2   | All MCs   | 91                    | 10.5 | 91                    | 10.5 | 0.432     | 44.7        | LOS D            | 3.9               | 29.6          | 0.96      | 0.77           | 0.96                | 13.8             |
| Approach                     |      |           | 460                   | 8.9  | 460                   | 8.9  | 0.567     | 36.2        | LOS C            | 9.1               | 68.3          | 0.92      | 0.77           | 0.92                | 16.3             |
| West: Park St (W)            |      |           |                       |      |                       |      |           |             |                  |                   |               |           |                |                     |                  |
| 11                           | T1   | All MCs   | 139                   | 30.3 | 139                   | 30.3 | 0.214     | 11.0        | LOS A            | 3.3               | 25.2          | 0.56      | 0.50           | 0.56                | 19.2             |
| 12                           | R2   | All MCs   | 49                    | 25.5 | 49                    | 25.5 | *0.214    | 15.1        | LOS B            | 3.3               | 25.2          | 0.59      | 0.54           | 0.59                | 15.4             |
| Approach                     |      |           | 188                   | 29.1 | 188                   | 29.1 | 0.214     | 12.1        | LOS A            | 3.3               | 25.2          | 0.57      | 0.51           | 0.57                | 18.3             |
| All Vehicles                 |      |           | 1142                  | 14.9 | 1142                  | 14.9 | 0.567     | 21.7        | LOS B            | 9.1               | 68.3          | 0.70      | 0.62           | 0.70                | 15.5             |

Site Level of Service (LOS) Method: Delay (RTA NSW). Site LOS Method is specified in the Network Data dialog (Override Site Data tab).

Vehicle movement LOS values are based on average delay per movement.

Intersection and Approach LOS values are based on average delay for all vehicle movements.

Delay Model: SIDRA Standard (Control Delay: Geometric Delay is included).

Queue Model: SIDRA queue estimation methods are used for Back of Queue and Queue at Start of Green.

Gap-Acceptance Capacity Formula: SIDRA Standard (Akçelik M3D).

HV (%) values are calculated for All Movement Classes of All Heavy Vehicle Model Designation.

Arrival Flows used in performance calculations are adjusted to include any Initial Queued Demand and Upstream Capacity Constraint effects.

\* Critical Movement (Signal Timing)

| Pedestrian Movement Performance |          |           |             |                  |                       |        |           |                |             |              |             |
|---------------------------------|----------|-----------|-------------|------------------|-----------------------|--------|-----------|----------------|-------------|--------------|-------------|
| Mov ID                          | Crossing | Dem. Flow | Aver. Delay | Level of Service | AVERAGE BACK OF QUEUE |        | Prop. Que | Eff. Stop Rate | Travel Time | Travel Dist. | Aver. Speed |
|                                 |          | ped/h     | sec         |                  | [ Ped                 | Dist ] |           |                | sec         | m            | m/sec       |
|                                 |          |           |             |                  | ped                   | m      |           |                |             |              |             |
| South: Castlereagh St (S)       |          |           |             |                  |                       |        |           |                |             |              |             |
| P1                              | Full     | 801       | 40.1        | LOS E            | 2.0                   | 2.0    | 0.95      | 0.95           | 56.8        | 20.0         | 0.35        |
| East: Park St (E)               |          |           |             |                  |                       |        |           |                |             |              |             |
| P2                              | Full     | 283       | 33.8        | LOS D            | 0.6                   | 0.6    | 0.87      | 0.87           | 50.5        | 20.0         | 0.40        |
| North: Castlereagh St (N)       |          |           |             |                  |                       |        |           |                |             |              |             |
| P3                              | Full     | 581       | 36.9        | LOS D            | 1.4                   | 1.4    | 0.91      | 0.91           | 53.6        | 20.0         | 0.37        |
| West: Park St (W)               |          |           |             |                  |                       |        |           |                |             |              |             |
| P4                              | Full     | 333       | 33.9        | LOS D            | 0.7                   | 0.7    | 0.87      | 0.87           | 50.6        | 20.0         | 0.40        |
| All Pedestrians                 |          | 1998      | 37.3        | LOS D            | 2.0                   | 2.0    | 0.92      | 0.92           | 53.9        | 20.0         | 0.37        |

Level of Service (LOS) Method: SIDRA Pedestrian LOS Method (Based on Average Delay)

Pedestrian movement LOS values are based on average delay per pedestrian movement.

Intersection LOS value for Pedestrians is based on average delay for all pedestrian movements.

**SIDRA INTERSECTION 9.1 | Copyright © 2000-2022 Akcelik and Associates Pty Ltd | sidrasolutions.com**

Organisation: AECOM AUSTRALIA PTY LTD | Licence: NETWORK / Enterprise Level 1 | Processed: Friday, 14 July 2023 11:24:47 AM

Project: C:\Users\YeungMA\Documents\ANZ-NAC-Sydney Metro-Sydney Metro C&SW Operational Monitoring - General\400\_Technical\432\_Traffic Analysis\SIDRA Modelling\01 Models (Geometry Only)\Block 1\Rev1\_Review\06 SM C&SW\_PIT (Block 1)\_PS.sip9

# MOVEMENT SUMMARY

Site: PIT04 [PIT04 Park St / Pitt St (Site Folder: Block 1 Model - 2023 AM Peak)]

Output produced by SIDRA INTERSECTION Version: 9.1.1.200

Network: PIT-N1 [PIT Network 1 (Network Folder: Block 1 Network - 2023 AM Peak)]

TCS 235

Site Category: (None)

Signals - EQUISAT (Fixed-Time/SCATS) Isolated Cycle Time = 91 seconds (Site User-Given Phase Times)

| Vehicle Movement Performance |      |           |                       |      |                       |      |           |             |                  |                   |             |           |                |                     |                  |
|------------------------------|------|-----------|-----------------------|------|-----------------------|------|-----------|-------------|------------------|-------------------|-------------|-----------|----------------|---------------------|------------------|
| Mov ID                       | Turn | Mov Class | Demand Flows          |      | Arrival Flows         |      | Deg. Satn | Aver. Delay | Level of Service | 95% Back Of Queue |             | Prop. Que | Eff. Stop Rate | Aver. No. of Cycles | Aver. Speed km/h |
|                              |      |           | [ Total HV ]<br>veh/h | %    | [ Total HV ]<br>veh/h | %    |           |             |                  | [ Veh. veh        | Dist ]<br>m |           |                |                     |                  |
| South: Pitt St (S)           |      |           |                       |      |                       |      |           |             |                  |                   |             |           |                |                     |                  |
| 1                            | L2   | All MCs   | 136                   | 6.2  | 136                   | 6.2  | * 0.887   | 36.8        | LOS C            | 4.3               | 32.1        | 1.00      | 0.99           | 1.48                | 13.3             |
| 2                            | T1   | All MCs   | 274                   | 6.5  | 274                   | 6.5  | 0.537     | 26.7        | LOS B            | 5.8               | 42.6        | 0.86      | 0.72           | 0.86                | 28.2             |
| 3                            | R2   | All MCs   | 97                    | 3.3  | 97                    | 3.3  | 0.351     | 36.2        | LOS C            | 2.3               | 16.3        | 0.93      | 0.75           | 0.93                | 13.9             |
| Approach                     |      |           | 506                   | 5.8  | 506                   | 5.8  | 0.887     | 31.2        | LOS C            | 5.8               | 42.6        | 0.91      | 0.80           | 1.04                | 21.4             |
| East: Park St (E)            |      |           |                       |      |                       |      |           |             |                  |                   |             |           |                |                     |                  |
| 5                            | T1   | All MCs   | 393                   | 19.6 | 393                   | 19.6 | 0.738     | 14.6        | LOS B            | 9.5               | 69.9        | 0.89      | 0.79           | 0.93                | 18.8             |
| 6                            | R2   | All MCs   | 95                    | 3.3  | 95                    | 3.3  | * 0.738   | 19.9        | LOS B            | 9.5               | 69.9        | 0.93      | 0.84           | 0.97                | 24.6             |
| Approach                     |      |           | 487                   | 16.4 | 487                   | 16.4 | 0.738     | 15.7        | LOS B            | 9.5               | 69.9        | 0.90      | 0.80           | 0.93                | 20.4             |
| West: Park St (W)            |      |           |                       |      |                       |      |           |             |                  |                   |             |           |                |                     |                  |
| 10                           | L2   | All MCs   | 1                     | 100. | 1                     | 100. | 0.136     | 18.2        | LOS B            | 0.8               | 10.2        | 0.68      | 0.53           | 0.68                | 28.1             |
| 11                           | T1   | All MCs   | 49                    | 100. | 49                    | 100. | 0.136     | 10.3        | LOS A            | 0.8               | 10.2        | 0.68      | 0.53           | 0.68                | 16.7             |
| Approach                     |      |           | 51                    | 100. | 51                    | 100. | 0.136     | 10.4        | LOS A            | 0.8               | 10.2        | 0.68      | 0.53           | 0.68                | 17.2             |
| All Vehicles                 |      |           | 1044                  | 15.3 | 1044                  | 15.3 | 0.887     | 23.0        | LOS B            | 9.5               | 69.9        | 0.90      | 0.79           | 0.97                | 20.9             |

Site Level of Service (LOS) Method: Delay (RTA NSW). Site LOS Method is specified in the Network Data dialog (Override Site Data tab).

Vehicle movement LOS values are based on average delay per movement.

Intersection and Approach LOS values are based on average delay for all vehicle movements.

Delay Model: SIDRA Standard (Control Delay: Geometric Delay is included).

Queue Model: SIDRA queue estimation methods are used for Back of Queue and Queue at Start of Green.

Gap-Acceptance Capacity Formula: SIDRA Standard (Akçelik M3D).

HV (%) values are calculated for All Movement Classes of All Heavy Vehicle Model Designation.

Arrival Flows used in performance calculations are adjusted to include any Initial Queued Demand and Upstream Capacity Constraint effects.

\* Critical Movement (Signal Timing)



| Pedestrian Movement Performance |          |           |             |                  |                       |        |           |                |             |              |             |
|---------------------------------|----------|-----------|-------------|------------------|-----------------------|--------|-----------|----------------|-------------|--------------|-------------|
| Mov ID                          | Crossing | Dem. Flow | Aver. Delay | Level of Service | AVERAGE BACK OF QUEUE |        | Prop. Que | Eff. Stop Rate | Travel Time | Travel Dist. | Aver. Speed |
|                                 |          | ped/h     | sec         |                  | [ Ped                 | Dist ] |           |                | sec         | m            | m/sec       |
|                                 |          |           |             |                  | ped                   | m      |           |                |             |              |             |
| South: Pitt St (S)              |          |           |             |                  |                       |        |           |                |             |              |             |
| P1                              | Full     | 991       | 17.1        | LOS B            | 1.2                   | 1.2    | 0.88      | 0.88           | 33.8        | 20.0         | 0.59        |
| East: Park St (E)               |          |           |             |                  |                       |        |           |                |             |              |             |
| P2                              | Full     | 385       | 13.4        | LOS B            | 0.4                   | 0.4    | 0.77      | 0.77           | 30.1        | 20.0         | 0.66        |
| North: Pitt St (N)              |          |           |             |                  |                       |        |           |                |             |              |             |
| P3                              | Full     | 584       | 18.6        | LOS B            | 0.7                   | 0.7    | 0.91      | 0.91           | 35.3        | 20.0         | 0.57        |
| West: Park St (W)               |          |           |             |                  |                       |        |           |                |             |              |             |
| P4                              | Full     | 806       | 12.9        | LOS B            | 0.9                   | 0.9    | 0.76      | 0.76           | 29.6        | 20.0         | 0.68        |
| All Pedestrians                 |          | 2766      | 15.7        | LOS B            | 1.2                   | 1.2    | 0.84      | 0.84           | 32.4        | 20.0         | 0.62        |

Level of Service (LOS) Method: SIDRA Pedestrian LOS Method (Based on Average Delay)

Pedestrian movement LOS values are based on average delay per pedestrian movement.

Intersection LOS value for Pedestrians is based on average delay for all pedestrian movements.

**SIDRA INTERSECTION 9.1 | Copyright © 2000-2022 Akcelik and Associates Pty Ltd | sidrasolutions.com**

Organisation: AECOM AUSTRALIA PTY LTD | Licence: NETWORK / Enterprise Level 1 | Processed: Friday, 14 July 2023 11:24:47 AM

Project: C:\Users\YeungMAECOMANZ-NAC-Sydney Metro-Sydney Metro C&SW Operational Monitoring - General\400\_Technical\432\_Traffic Analysis\SIDRA Modelling\01 Models (Geometry Only)\Block 1\Rev1\_Review\06 SM C&SW\_PIT (Block 1)\_PS.sip9

# MOVEMENT SUMMARY

Site: PIT01 [PIT01 Pitt St / Bathurst St (Site Folder: Block 1 Model - 2023 PM Peak)]

Output produced by SIDRA INTERSECTION Version: 9.1.1.200

Network: PIT-N1 [PIT Network 1 (Network Folder: Block 1 Network - 2023 PM Peak)]

TCS 2312

Site Category: (None)

Signals - EQUISAT (Fixed-Time/SCATS) Coordinated Cycle Time = 90 seconds (Network Site User-Given Phase Times)

| Vehicle Movement Performance |      |           |              |     |               |     |           |             |                  |                   |          |           |                |                     |             |
|------------------------------|------|-----------|--------------|-----|---------------|-----|-----------|-------------|------------------|-------------------|----------|-----------|----------------|---------------------|-------------|
| Mov ID                       | Turn | Mov Class | Demand Flows |     | Arrival Flows |     | Deg. Satn | Aver. Delay | Level of Service | 95% Back Of Queue |          | Prop. Que | Eff. Stop Rate | Aver. No. of Cycles | Aver. Speed |
|                              |      |           | [ Total HV ] | %   | [ Total HV ]  | %   |           |             |                  | [ Veh. veh        | Dist ] m |           |                |                     |             |
| South: Pitt St (S)           |      |           |              |     |               |     |           |             |                  |                   |          |           |                |                     |             |
| 2                            | T1   | All MCs   | 298          | 0.4 | 298           | 0.4 | 0.432     | 39.9        | LOS C            | 7.7               | 54.3     | 0.89      | 0.73           | 0.89                | 16.2        |
| 3                            | R2   | All MCs   | 164          | 3.2 | 164           | 3.2 | *0.690    | 70.8        | LOS F            | 7.1               | 51.4     | 0.98      | 0.85           | 1.08                | 13.0        |
| Approach                     |      |           | 462          | 1.4 | 462           | 1.4 | 0.690     | 50.9        | LOS D            | 7.7               | 54.3     | 0.92      | 0.77           | 0.96                | 14.9        |
| West: Bathurst St (W)        |      |           |              |     |               |     |           |             |                  |                   |          |           |                |                     |             |
| 10                           | L2   | All MCs   | 191          | 4.4 | 191           | 4.4 | 0.226     | 17.2        | LOS B            | 4.1               | 29.9     | 0.53      | 0.66           | 0.53                | 15.4        |
| 11                           | T1   | All MCs   | 1149         | 1.6 | 1149          | 1.6 | *0.347    | 9.7         | LOS A            | 8.7               | 61.4     | 0.52      | 0.45           | 0.52                | 19.6        |
| Approach                     |      |           | 1340         | 2.0 | 1340          | 2.0 | 0.347     | 10.7        | LOS A            | 8.7               | 61.4     | 0.52      | 0.48           | 0.52                | 18.9        |
| All Vehicles                 |      |           | 1802         | 1.8 | 1802          | 1.8 | 0.690     | 21.0        | LOS B            | 8.7               | 61.4     | 0.62      | 0.56           | 0.63                | 16.8        |

Site Level of Service (LOS) Method: Delay (RTA NSW). Site LOS Method is specified in the Network Data dialog (Override Site Data tab).

Vehicle movement LOS values are based on average delay per movement.

Intersection and Approach LOS values are based on average delay for all vehicle movements.

Delay Model: SIDRA Standard (Control Delay: Geometric Delay is included).

Queue Model: SIDRA queue estimation methods are used for Back of Queue and Queue at Start of Green.

Gap-Acceptance Capacity Formula: SIDRA Standard (Akçelik M3D).

HV (%) values are calculated for All Movement Classes of All Heavy Vehicle Model Designation.

Arrival Flows used in performance calculations are adjusted to include any Initial Queued Demand and Upstream Capacity Constraint effects.

\* Critical Movement (Signal Timing)

| Pedestrian Movement Performance |          |           |             |                  |                       |        |           |                |             |              |             |
|---------------------------------|----------|-----------|-------------|------------------|-----------------------|--------|-----------|----------------|-------------|--------------|-------------|
| Mov ID                          | Crossing | Dem. Flow | Aver. Delay | Level of Service | AVERAGE BACK OF QUEUE |        | Prop. Que | Eff. Stop Rate | Travel Time | Travel Dist. | Aver. Speed |
|                                 |          | ped/h     | sec         |                  | [ Ped                 | Dist ] |           |                | sec         | m            | m/sec       |
|                                 |          |           |             |                  | ped                   | m      |           |                |             |              |             |
| South: Pitt St (S)              |          |           |             |                  |                       |        |           |                |             |              |             |
| P1                              | Full     | 714       | 40.4        | LOS E            | 1.8                   | 1.8    | 0.96      | 0.96           | 57.1        | 20.0         | 0.35        |
| East: Bathurst St (E)           |          |           |             |                  |                       |        |           |                |             |              |             |
| P2                              | Full     | 589       | 40.2        | LOS E            | 1.4                   | 1.4    | 0.96      | 0.96           | 56.9        | 20.0         | 0.35        |
| North: Pitt St (N)              |          |           |             |                  |                       |        |           |                |             |              |             |
| P3                              | Full     | 1135      | 41.1        | LOS E            | 2.8                   | 2.8    | 0.98      | 0.98           | 57.8        | 20.0         | 0.35        |
| West: Bathurst St (W)           |          |           |             |                  |                       |        |           |                |             |              |             |
| P4                              | Full     | 927       | 37.9        | LOS D            | 2.2                   | 2.2    | 0.94      | 0.94           | 54.6        | 20.0         | 0.37        |
| All Pedestrians                 |          | 3365      | 39.9        | LOS D            | 2.8                   | 2.8    | 0.96      | 0.96           | 56.6        | 20.0         | 0.35        |

Level of Service (LOS) Method: SIDRA Pedestrian LOS Method (Based on Average Delay)

Pedestrian movement LOS values are based on average delay per pedestrian movement.

Intersection LOS value for Pedestrians is based on average delay for all pedestrian movements.

**SIDRA INTERSECTION 9.1 | Copyright © 2000-2022 Akcelik and Associates Pty Ltd | sidrasolutions.com**

Organisation: AECOM AUSTRALIA PTY LTD | Licence: NETWORK / Enterprise Level 1 | Processed: Friday, 14 July 2023 11:24:49 AM

Project: C:\Users\YeungMA\AECOM\ANZ-NAC-Sydney Metro-Sydney Metro C&SW Operational Monitoring - General\400\_Technical\432\_Traffic Analysis\SIDRA Modelling\01 Models (Geometry Only)\Block 1\Rev1\_Review\06 SM C&SW\_PIT (Block 1)\_PS.sip9

# MOVEMENT SUMMARY

Site: PIT02 [PIT02 Castlereagh St / Bathurst St (Site Folder: Block 1 Model - 2023 PM Peak)]

Output produced by SIDRA INTERSECTION Version: 9.1.1.200

Network: PIT-N1 [PIT Network 1 (Network Folder: Block 1 Network - 2023 PM Peak)]

TCS 2281

Site Category: (None)

Signals - EQUISAT (Fixed-Time/SCATS) Coordinated Cycle Time = 90 seconds (Network Site User-Given Phase Times)

| Vehicle Movement Performance |      |           |              |      |               |      |           |             |                  |                   |        |           |                |                     |             |
|------------------------------|------|-----------|--------------|------|---------------|------|-----------|-------------|------------------|-------------------|--------|-----------|----------------|---------------------|-------------|
| Mov ID                       | Turn | Mov Class | Demand Flows |      | Arrival Flows |      | Deg. Satn | Aver. Delay | Level of Service | 95% Back Of Queue |        | Prop. Que | Eff. Stop Rate | Aver. No. of Cycles | Aver. Speed |
|                              |      |           | [ Total HV ] | %    | [ Total HV ]  | %    |           |             |                  | [ Veh. veh        | Dist ] |           |                |                     |             |
|                              |      |           | veh/h        | %    | veh/h         | %    | v/c       | sec         |                  |                   | m      |           |                |                     | km/h        |
| North: Castlereagh St (N)    |      |           |              |      |               |      |           |             |                  |                   |        |           |                |                     |             |
| 7                            | L2   | All MCs   | 140          | 9.8  | 140           | 9.8  | *0.441    | 39.3        | LOS C            | 5.6               | 42.6   | 0.93      | 0.78           | 0.93                | 11.5        |
| 8                            | T1   | All MCs   | 285          | 22.1 | 285           | 22.1 | 0.439     | 29.7        | LOS C            | 8.3               | 59.0   | 0.87      | 0.71           | 0.87                | 21.1        |
| Approach                     |      |           | 425          | 18.1 | 425           | 18.1 | 0.441     | 32.8        | LOS C            | 8.3               | 59.0   | 0.89      | 0.74           | 0.89                | 18.1        |
| West: Bathurst St (W)        |      |           |              |      |               |      |           |             |                  |                   |        |           |                |                     |             |
| 11                           | T1   | All MCs   | 1153         | 1.7  | 1153          | 1.7  | 0.292     | 3.9         | LOS A            | 5.9               | 41.8   | 0.25      | 0.23           | 0.25                | 28.7        |
| 12                           | R2   | All MCs   | 143          | 3.7  | 143           | 3.7  | *0.292    | 14.0        | LOS A            | 5.1               | 36.7   | 0.44      | 0.53           | 0.44                | 27.9        |
| Approach                     |      |           | 1296         | 1.9  | 1296          | 1.9  | 0.292     | 5.0         | LOS A            | 5.9               | 41.8   | 0.27      | 0.27           | 0.27                | 28.5        |
| All Vehicles                 |      |           | 1721         | 5.9  | 1721          | 5.9  | 0.441     | 11.9        | LOS A            | 8.3               | 59.0   | 0.42      | 0.38           | 0.42                | 23.1        |

Site Level of Service (LOS) Method: Delay (RTA NSW). Site LOS Method is specified in the Network Data dialog (Override Site Data tab).

Vehicle movement LOS values are based on average delay per movement.

Intersection and Approach LOS values are based on average delay for all vehicle movements.

Delay Model: SIDRA Standard (Control Delay: Geometric Delay is included).

Queue Model: SIDRA queue estimation methods are used for Back of Queue and Queue at Start of Green.

Gap-Acceptance Capacity Formula: SIDRA Standard (Akçelik M3D).

HV (%) values are calculated for All Movement Classes of All Heavy Vehicle Model Designation.

Arrival Flows used in performance calculations are adjusted to include any Initial Queued Demand and Upstream Capacity Constraint effects.

\* Critical Movement (Signal Timing)

| Pedestrian Movement Performance |          |           |             |                  |                       |        |           |                |             |              |             |
|---------------------------------|----------|-----------|-------------|------------------|-----------------------|--------|-----------|----------------|-------------|--------------|-------------|
| Mov ID                          | Crossing | Dem. Flow | Aver. Delay | Level of Service | AVERAGE BACK OF QUEUE |        | Prop. Que | Eff. Stop Rate | Travel Time | Travel Dist. | Aver. Speed |
|                                 |          | ped/h     | sec         |                  | [ Ped                 | Dist ] |           |                | sec         | m            | m/sec       |
|                                 |          |           |             |                  | ped                   | m      |           |                |             |              |             |
| South: Castlereagh St (S)       |          |           |             |                  |                       |        |           |                |             |              |             |
| P1                              | Full     | 409       | 35.3        | LOS D            | 0.9                   | 0.9    | 0.89      | 0.89           | 51.9        | 20.0         | 0.39        |
| East: Bathurst St (E)           |          |           |             |                  |                       |        |           |                |             |              |             |
| P2                              | Full     | 293       | 34.2        | LOS D            | 0.7                   | 0.7    | 0.88      | 0.88           | 50.9        | 20.0         | 0.39        |
| North: Castlereagh St (N)       |          |           |             |                  |                       |        |           |                |             |              |             |
| P3                              | Full     | 1037      | 40.0        | LOS E            | 2.6                   | 2.6    | 0.96      | 0.96           | 56.7        | 20.0         | 0.35        |
| West: Bathurst St (W)           |          |           |             |                  |                       |        |           |                |             |              |             |
| P4                              | Full     | 1064      | 36.3        | LOS D            | 2.5                   | 2.5    | 0.92      | 0.92           | 52.9        | 20.0         | 0.38        |
| All Pedestrians                 |          | 2803      | 37.3        | LOS D            | 2.6                   | 2.6    | 0.93      | 0.93           | 54.0        | 20.0         | 0.37        |

Level of Service (LOS) Method: SIDRA Pedestrian LOS Method (Based on Average Delay)

Pedestrian movement LOS values are based on average delay per pedestrian movement.

Intersection LOS value for Pedestrians is based on average delay for all pedestrian movements.

**SIDRA INTERSECTION 9.1 | Copyright © 2000-2022 Akcelik and Associates Pty Ltd | sidrasolutions.com**

Organisation: AECOM AUSTRALIA PTY LTD | Licence: NETWORK / Enterprise Level 1 | Processed: Friday, 14 July 2023 11:24:49 AM

Project: C:\Users\YeungMA\AECOM\ANZ-NAC-Sydney Metro-Sydney Metro C&SW Operational Monitoring - General\400\_Technical\432\_Traffic Analysis\SIDRA Modelling\01 Models (Geometry Only)\Block 1\Rev1\_Review\06 SM C&SW\_PIT (Block 1)\_PS.sip9

# MOVEMENT SUMMARY

Site: PIT03 [PIT03 Park St / Castlereagh St (Site Folder: Block 1 Model - 2023 PM Peak)]

Output produced by SIDRA INTERSECTION Version: 9.1.1.200

Network: PIT-N1 [PIT Network 1 (Network Folder: Block 1 Network - 2023 PM Peak)]

TCS 250

Site Category: (None)

Signals - EQUISAT (Fixed-Time/SCATS) Isolated Cycle Time = 91 seconds (Site User-Given Phase Times)

| Vehicle Movement Performance |      |           |                       |      |                       |      |           |             |                  |                   |               |           |                |                     |                  |
|------------------------------|------|-----------|-----------------------|------|-----------------------|------|-----------|-------------|------------------|-------------------|---------------|-----------|----------------|---------------------|------------------|
| Mov ID                       | Turn | Mov Class | Demand Flows          |      | Arrival Flows         |      | Deg. Satn | Aver. Delay | Level of Service | 95% Back Of Queue |               | Prop. Que | Eff. Stop Rate | Aver. No. of Cycles | Aver. Speed km/h |
|                              |      |           | [ Total HV ]<br>veh/h | %    | [ Total HV ]<br>veh/h | %    |           |             |                  | [ Veh. veh        | [ Dist ]<br>m |           |                |                     |                  |
| East: Park St (E)            |      |           |                       |      |                       |      |           |             |                  |                   |               |           |                |                     |                  |
| 4                            | L2   | All MCs   | 61                    | 12.1 | 61                    | 12.1 | 0.100     | 16.5        | LOS B            | 1.7               | 14.6          | 0.56      | 0.61           | 0.56                | 9.1              |
| 5                            | T1   | All MCs   | 433                   | 16.5 | 433                   | 16.5 | *0.349    | 11.9        | LOS A            | 9.0               | 63.9          | 0.58      | 0.51           | 0.58                | 11.1             |
| Approach                     |      |           | 494                   | 16.0 | 494                   | 16.0 | 0.349     | 12.5        | LOS A            | 9.0               | 63.9          | 0.58      | 0.52           | 0.58                | 10.8             |
| North: Castlereagh St (N)    |      |           |                       |      |                       |      |           |             |                  |                   |               |           |                |                     |                  |
| 7                            | L2   | All MCs   | 151                   | 0.7  | 151                   | 0.7  | 0.286     | 30.8        | LOS C            | 5.2               | 36.9          | 0.82      | 0.75           | 0.82                | 18.4             |
| 8                            | T1   | All MCs   | 273                   | 19.7 | 273                   | 19.7 | 0.674     | 54.1        | LOS D            | 9.5               | 67.8          | 0.94      | 0.81           | 0.98                | 16.5             |
| 9                            | R2   | All MCs   | 86                    | 7.3  | 86                    | 7.3  | *0.772    | 74.5        | LOS F            | 4.1               | 30.9          | 1.00      | 0.95           | 1.32                | 12.5             |
| Approach                     |      |           | 509                   | 12.0 | 509                   | 12.0 | 0.772     | 50.7        | LOS D            | 9.5               | 67.8          | 0.92      | 0.81           | 0.99                | 16.2             |
| West: Park St (W)            |      |           |                       |      |                       |      |           |             |                  |                   |               |           |                |                     |                  |
| 11                           | T1   | All MCs   | 174                   | 27.3 | 174                   | 27.3 | 0.298     | 12.7        | LOS A            | 4.9               | 37.8          | 0.61      | 0.54           | 0.61                | 17.9             |
| 12                           | R2   | All MCs   | 65                    | 32.3 | 65                    | 32.3 | *0.298    | 17.0        | LOS B            | 4.9               | 37.8          | 0.64      | 0.59           | 0.64                | 14.1             |
| Approach                     |      |           | 239                   | 28.6 | 239                   | 28.6 | 0.298     | 13.8        | LOS A            | 4.9               | 37.8          | 0.62      | 0.55           | 0.62                | 16.9             |
| All Vehicles                 |      |           | 1242                  | 16.8 | 1242                  | 16.8 | 0.772     | 28.4        | LOS B            | 9.5               | 67.8          | 0.73      | 0.65           | 0.76                | 15.3             |

Site Level of Service (LOS) Method: Delay (RTA NSW). Site LOS Method is specified in the Network Data dialog (Override Site Data tab).

Vehicle movement LOS values are based on average delay per movement.

Intersection and Approach LOS values are based on average delay for all vehicle movements.

Delay Model: SIDRA Standard (Control Delay: Geometric Delay is included).

Queue Model: SIDRA queue estimation methods are used for Back of Queue and Queue at Start of Green.

Gap-Acceptance Capacity Formula: SIDRA Standard (Akçelik M3D).

HV (%) values are calculated for All Movement Classes of All Heavy Vehicle Model Designation.

Arrival Flows used in performance calculations are adjusted to include any Initial Queued Demand and Upstream Capacity Constraint effects.

\* Critical Movement (Signal Timing)

| Pedestrian Movement Performance |          |           |             |                  |                       |        |           |                |             |              |             |
|---------------------------------|----------|-----------|-------------|------------------|-----------------------|--------|-----------|----------------|-------------|--------------|-------------|
| Mov ID                          | Crossing | Dem. Flow | Aver. Delay | Level of Service | AVERAGE BACK OF QUEUE |        | Prop. Que | Eff. Stop Rate | Travel Time | Travel Dist. | Aver. Speed |
|                                 |          | ped/h     | sec         |                  | [ Ped                 | Dist ] |           |                | sec         | m            | m/sec       |
|                                 |          |           |             |                  | ped                   | m      |           |                |             |              |             |
| South: Castlereagh St (S)       |          |           |             |                  |                       |        |           |                |             |              |             |
| P1                              | Full     | 1183      | 40.8        | LOS E            | 3.0                   | 3.0    | 0.97      | 0.97           | 57.4        | 20.0         | 0.35        |
| East: Park St (E)               |          |           |             |                  |                       |        |           |                |             |              |             |
| P2                              | Full     | 327       | 33.9        | LOS D            | 0.7                   | 0.7    | 0.87      | 0.87           | 50.6        | 20.0         | 0.40        |
| North: Castlereagh St (N)       |          |           |             |                  |                       |        |           |                |             |              |             |
| P3                              | Full     | 1086      | 37.8        | LOS D            | 2.6                   | 2.6    | 0.93      | 0.93           | 54.4        | 20.0         | 0.37        |
| West: Park St (W)               |          |           |             |                  |                       |        |           |                |             |              |             |
| P4                              | Full     | 573       | 34.2        | LOS D            | 1.3                   | 1.3    | 0.88      | 0.88           | 50.9        | 20.0         | 0.39        |
| All Pedestrians                 |          | 3169      | 37.9        | LOS D            | 3.0                   | 3.0    | 0.93      | 0.93           | 54.5        | 20.0         | 0.37        |

Level of Service (LOS) Method: SIDRA Pedestrian LOS Method (Based on Average Delay)

Pedestrian movement LOS values are based on average delay per pedestrian movement.

Intersection LOS value for Pedestrians is based on average delay for all pedestrian movements.

**SIDRA INTERSECTION 9.1 | Copyright © 2000-2022 Akcelik and Associates Pty Ltd | sidrasolutions.com**

Organisation: AECOM AUSTRALIA PTY LTD | Licence: NETWORK / Enterprise Level 1 | Processed: Friday, 14 July 2023 11:24:49 AM

Project: C:\Users\YeungMAECOMANZ-NAC-Sydney Metro-Sydney Metro C&SW Operational Monitoring - General\400\_Technical\432\_Traffic Analysis\SIDRA Modelling\01 Models (Geometry Only)\Block 1\Rev1\_Review\06 SM C&SW\_PIT (Block 1)\_PS.sip9

# MOVEMENT SUMMARY

Site: PIT04 [PIT04 Park St / Pitt St (Site Folder: Block 1 Model - 2023 PM Peak)]

Output produced by SIDRA INTERSECTION Version: 9.1.1.200

Network: PIT-N1 [PIT Network 1 (Network Folder: Block 1 Network - 2023 PM Peak)]

TCS 235

Site Category: (None)

Signals - EQUISAT (Fixed-Time/SCATS) Isolated Cycle Time = 90 seconds (Site User-Given Phase Times)

| Vehicle Movement Performance |      |           |                       |      |                       |      |           |             |                  |                   |             |           |                |                     |                  |
|------------------------------|------|-----------|-----------------------|------|-----------------------|------|-----------|-------------|------------------|-------------------|-------------|-----------|----------------|---------------------|------------------|
| Mov ID                       | Turn | Mov Class | Demand Flows          |      | Arrival Flows         |      | Deg. Satn | Aver. Delay | Level of Service | 95% Back Of Queue |             | Prop. Que | Eff. Stop Rate | Aver. No. of Cycles | Aver. Speed km/h |
|                              |      |           | [ Total HV ]<br>veh/h | %    | [ Total HV ]<br>veh/h | %    |           |             |                  | [ Veh. veh        | Dist ]<br>m |           |                |                     |                  |
| South: Pitt St (S)           |      |           |                       |      |                       |      |           |             |                  |                   |             |           |                |                     |                  |
| 1                            | L2   | All MCs   | 151                   | 5.6  | 151                   | 5.6  | *0.967    | 51.3        | LOS D            | 5.8               | 42.4        | 1.00      | 1.12           | 1.76                | 10.6             |
| 2                            | T1   | All MCs   | 224                   | 0.0  | 224                   | 0.0  | 0.407     | 20.6        | LOS B            | 4.3               | 30.4        | 0.82      | 0.67           | 0.82                | 28.9             |
| 3                            | R2   | All MCs   | 116                   | 2.7  | 116                   | 2.7  | 0.601     | 34.1        | LOS C            | 2.9               | 20.9        | 1.00      | 0.79           | 1.03                | 12.9             |
| Approach                     |      |           | 491                   | 2.4  | 491                   | 2.4  | 0.967     | 33.2        | LOS C            | 5.8               | 42.4        | 0.91      | 0.84           | 1.16                | 18.4             |
| East: Park St (E)            |      |           |                       |      |                       |      |           |             |                  |                   |             |           |                |                     |                  |
| 5                            | T1   | All MCs   | 460                   | 16.7 | 460                   | 16.7 | 0.697     | 13.2        | LOS A            | 8.9               | 63.4        | 0.88      | 0.75           | 0.88                | 20.0             |
| 6                            | R2   | All MCs   | 59                    | 1.8  | 59                    | 1.8  | *0.697    | 19.2        | LOS B            | 8.9               | 63.4        | 0.91      | 0.79           | 0.91                | 25.7             |
| Approach                     |      |           | 519                   | 15.0 | 519                   | 15.0 | 0.697     | 13.9        | LOS A            | 8.9               | 63.4        | 0.88      | 0.76           | 0.88                | 20.9             |
| West: Park St (W)            |      |           |                       |      |                       |      |           |             |                  |                   |             |           |                |                     |                  |
| 10                           | L2   | All MCs   | 100                   | 0    | 100                   | 0    | 0.178     | 18.6        | LOS B            | 1.0               | 13.4        | 0.70      | 0.55           | 0.70                | 27.9             |
| 11                           | T1   | All MCs   | 64                    | 100  | 64                    | 100  | 0.178     | 10.6        | LOS A            | 1.0               | 13.4        | 0.70      | 0.55           | 0.70                | 16.4             |
| Approach                     |      |           | 65                    | 100  | 65                    | 100  | 0.178     | 10.8        | LOS A            | 1.0               | 13.4        | 0.70      | 0.55           | 0.70                | 16.8             |
| All Vehicles                 |      |           | 1075                  | 14.4 | 1075                  | 14.4 | 0.967     | 22.5        | LOS B            | 8.9               | 63.4        | 0.89      | 0.78           | 1.00                | 19.3             |

Site Level of Service (LOS) Method: Delay (RTA NSW). Site LOS Method is specified in the Network Data dialog (Override Site Data tab).

Vehicle movement LOS values are based on average delay per movement.

Intersection and Approach LOS values are based on average delay for all vehicle movements.

Delay Model: SIDRA Standard (Control Delay: Geometric Delay is included).

Queue Model: SIDRA queue estimation methods are used for Back of Queue and Queue at Start of Green.

Gap-Acceptance Capacity Formula: SIDRA Standard (Akçelik M3D).

HV (%) values are calculated for All Movement Classes of All Heavy Vehicle Model Designation.

Arrival Flows used in performance calculations are adjusted to include any Initial Queued Demand and Upstream Capacity Constraint effects.

\* Critical Movement (Signal Timing)



| Pedestrian Movement Performance |          |           |             |                  |                       |        |           |                |             |              |             |
|---------------------------------|----------|-----------|-------------|------------------|-----------------------|--------|-----------|----------------|-------------|--------------|-------------|
| Mov ID                          | Crossing | Dem. Flow | Aver. Delay | Level of Service | AVERAGE BACK OF QUEUE |        | Prop. Que | Eff. Stop Rate | Travel Time | Travel Dist. | Aver. Speed |
|                                 |          | ped/h     | sec         |                  | [ Ped                 | Dist ] |           |                | sec         | m            | m/sec       |
|                                 |          |           |             |                  | ped                   | m      |           |                |             |              |             |
| South: Pitt St (S)              |          |           |             |                  |                       |        |           |                |             |              |             |
| P1                              | Full     | 1582      | 17.3        | LOS B            | 2.0                   | 2.0    | 0.90      | 0.90           | 34.0        | 20.0         | 0.59        |
| East: Park St (E)               |          |           |             |                  |                       |        |           |                |             |              |             |
| P2                              | Full     | 1468      | 13.8        | LOS B            | 1.6                   | 1.6    | 0.80      | 0.80           | 30.5        | 20.0         | 0.66        |
| North: Pitt St (N)              |          |           |             |                  |                       |        |           |                |             |              |             |
| P3                              | Full     | 1461      | 19.0        | LOS B            | 1.9                   | 1.9    | 0.95      | 0.95           | 35.7        | 20.0         | 0.56        |
| West: Park St (W)               |          |           |             |                  |                       |        |           |                |             |              |             |
| P4                              | Full     | 1529      | 13.0        | LOS B            | 1.7                   | 1.7    | 0.78      | 0.78           | 29.7        | 20.0         | 0.67        |
| All Pedestrians                 |          | 6041      | 15.8        | LOS B            | 2.0                   | 2.0    | 0.86      | 0.86           | 32.4        | 20.0         | 0.62        |

Level of Service (LOS) Method: SIDRA Pedestrian LOS Method (Based on Average Delay)

Pedestrian movement LOS values are based on average delay per pedestrian movement.

Intersection LOS value for Pedestrians is based on average delay for all pedestrian movements.

**SIDRA INTERSECTION 9.1 | Copyright © 2000-2022 Akcelik and Associates Pty Ltd | sidrasolutions.com**

Organisation: AECOM AUSTRALIA PTY LTD | Licence: NETWORK / Enterprise Level 1 | Processed: Friday, 14 July 2023 11:24:49 AM

Project: C:\Users\YeungMA\AECOM\ANZ-NAC-Sydney Metro-Sydney Metro C&SW Operational Monitoring - General\400\_Technical\432\_Traffic Analysis\SIDRA Modelling\01 Models (Geometry Only)\Block 1\Rev1\_Review\06 SM C&SW\_PIT (Block 1)\_PS.sip9

# MOVEMENT SUMMARY

Site: PIT01 [PIT01 Pitt St / Bathurst St (Site Folder: Block 1 Model - 2023 Weekend Peak)]

Output produced by SIDRA INTERSECTION Version: 9.1.1.200

Network: PIT-N1 [PIT Network 1 (Network Folder: Block 1 Network - 2023 Weekend Peak)]

TCS 2312

Site Category: (None)

Signals - EQUISAT (Fixed-Time/SCATS) Coordinated Cycle Time = 45 seconds (Network Site User-Given Phase Times)

| Vehicle Movement Performance |      |           |              |     |               |     |           |             |                  |                   |          |           |                |                     |             |
|------------------------------|------|-----------|--------------|-----|---------------|-----|-----------|-------------|------------------|-------------------|----------|-----------|----------------|---------------------|-------------|
| Mov ID                       | Turn | Mov Class | Demand Flows |     | Arrival Flows |     | Deg. Satn | Aver. Delay | Level of Service | 95% Back Of Queue |          | Prop. Que | Eff. Stop Rate | Aver. No. of Cycles | Aver. Speed |
|                              |      |           | [ Total HV ] | %   | [ Total HV ]  | %   |           |             |                  | [ Veh. veh        | Dist ] m |           |                |                     |             |
| South: Pitt St (S)           |      |           |              |     |               |     |           |             |                  |                   |          |           |                |                     |             |
| 2                            | T1   | All MCs   | 222          | 0.9 | 222           | 0.9 | 0.235     | 15.3        | LOS B            | 2.0               | 14.4     | 0.84      | 0.66           | 0.84                | 23.3        |
| 3                            | R2   | All MCs   | 107          | 4.9 | 107           | 4.9 | *0.391    | 23.8        | LOS B            | 2.3               | 16.7     | 0.94      | 0.77           | 0.94                | 18.6        |
| Approach                     |      |           | 329          | 2.2 | 329           | 2.2 | 0.391     | 18.1        | LOS B            | 2.3               | 16.7     | 0.87      | 0.69           | 0.87                | 21.5        |
| West: Bathurst St (W)        |      |           |              |     |               |     |           |             |                  |                   |          |           |                |                     |             |
| 10                           | L2   | All MCs   | 216          | 1.5 | 216           | 1.5 | 0.280     | 13.9        | LOS A            | 3.2               | 22.6     | 0.69      | 0.71           | 0.69                | 16.1        |
| 11                           | T1   | All MCs   | 1039         | 1.5 | 1039          | 1.5 | *0.381    | 8.3         | LOS A            | 5.0               | 35.8     | 0.67      | 0.57           | 0.67                | 20.6        |
| Approach                     |      |           | 1255         | 1.5 | 1255          | 1.5 | 0.381     | 9.2         | LOS A            | 5.0               | 35.8     | 0.67      | 0.59           | 0.67                | 19.6        |
| All Vehicles                 |      |           | 1584         | 1.7 | 1584          | 1.7 | 0.391     | 11.1        | LOS A            | 5.0               | 35.8     | 0.71      | 0.62           | 0.71                | 20.3        |

Site Level of Service (LOS) Method: Delay (RTA NSW). Site LOS Method is specified in the Network Data dialog (Override Site Data tab).

Vehicle movement LOS values are based on average delay per movement.

Intersection and Approach LOS values are based on average delay for all vehicle movements.

Delay Model: SIDRA Standard (Control Delay: Geometric Delay is included).

Queue Model: SIDRA queue estimation methods are used for Back of Queue and Queue at Start of Green.

Gap-Acceptance Capacity Formula: SIDRA Standard (Akçelik M3D).

HV (%) values are calculated for All Movement Classes of All Heavy Vehicle Model Designation.

Arrival Flows used in performance calculations are adjusted to include any Initial Queued Demand and Upstream Capacity Constraint effects.

\* Critical Movement (Signal Timing)

| Pedestrian Movement Performance |          |           |             |                  |                       |        |           |                |             |              |             |
|---------------------------------|----------|-----------|-------------|------------------|-----------------------|--------|-----------|----------------|-------------|--------------|-------------|
| Mov ID                          | Crossing | Dem. Flow | Aver. Delay | Level of Service | AVERAGE BACK OF QUEUE |        | Prop. Que | Eff. Stop Rate | Travel Time | Travel Dist. | Aver. Speed |
|                                 |          | ped/h     | sec         |                  | [ Ped                 | Dist ] |           |                | sec         | m            | m/sec       |
|                                 |          |           |             |                  | ped                   | m      |           |                |             |              |             |
| South: Pitt St (S)              |          |           |             |                  |                       |        |           |                |             |              |             |
| P1                              | Full     | 303       | 17.1        | LOS B            | 0.3                   | 0.3    | 0.88      | 0.88           | 33.8        | 20.0         | 0.59        |
| East: Bathurst St (E)           |          |           |             |                  |                       |        |           |                |             |              |             |
| P2                              | Full     | 301       | 17.1        | LOS B            | 0.3                   | 0.3    | 0.88      | 0.88           | 33.8        | 20.0         | 0.59        |
| North: Pitt St (N)              |          |           |             |                  |                       |        |           |                |             |              |             |
| P3                              | Full     | 198       | 17.0        | LOS B            | 0.2                   | 0.2    | 0.87      | 0.87           | 33.7        | 20.0         | 0.59        |
| West: Bathurst St (W)           |          |           |             |                  |                       |        |           |                |             |              |             |
| P4                              | Full     | 449       | 14.7        | LOS B            | 0.5                   | 0.5    | 0.82      | 0.82           | 31.3        | 20.0         | 0.64        |
| All Pedestrians                 |          | 1252      | 16.2        | LOS B            | 0.5                   | 0.5    | 0.85      | 0.85           | 32.9        | 20.0         | 0.61        |

Level of Service (LOS) Method: SIDRA Pedestrian LOS Method (Based on Average Delay)  
 Pedestrian movement LOS values are based on average delay per pedestrian movement.  
 Intersection LOS value for Pedestrians is based on average delay for all pedestrian movements.

# MOVEMENT SUMMARY

Site: PIT02 [PIT02 Castlereagh St / Bathurst St (Site Folder: Block 1 Model - 2023 Weekend Peak)]

Output produced by SIDRA INTERSECTION Version: 9.1.1.200

Network: PIT-N1 [PIT Network 1 (Network Folder: Block 1 Network - 2023 Weekend Peak)]

TCS 2281

Site Category: (None)

Signals - EQUISAT (Fixed-Time/SCATS) Coordinated Cycle Time = 45 seconds (Network Site User-Given Phase Times)

| Vehicle Movement Performance |      |           |              |     |               |     |           |             |                  |                   |        |           |                |                     |             |
|------------------------------|------|-----------|--------------|-----|---------------|-----|-----------|-------------|------------------|-------------------|--------|-----------|----------------|---------------------|-------------|
| Mov ID                       | Turn | Mov Class | Demand Flows |     | Arrival Flows |     | Deg. Satn | Aver. Delay | Level of Service | 95% Back Of Queue |        | Prop. Que | Eff. Stop Rate | Aver. No. of Cycles | Aver. Speed |
|                              |      |           | [ Total HV ] | %   | [ Total HV ]  | %   |           |             |                  | [ Veh. veh        | Dist ] |           |                |                     |             |
|                              |      |           | veh/h        | %   | veh/h         | %   | v/c       | sec         |                  |                   | m      |           |                |                     | km/h        |
| North: Castlereagh St (N)    |      |           |              |     |               |     |           |             |                  |                   |        |           |                |                     |             |
| 7                            | L2   | All MCs   | 73           | 1.4 | 73            | 1.4 | 0.162     | 18.4        | LOS B            | 1.3               | 9.3    | 0.82      | 0.71           | 0.82                | 18.2        |
| 8                            | T1   | All MCs   | 168          | 8.1 | 168           | 8.1 | *0.150    | 12.4        | LOS A            | 1.4               | 10.3   | 0.76      | 0.59           | 0.76                | 29.0        |
| Approach                     |      |           | 241          | 6.1 | 241           | 6.1 | 0.162     | 14.2        | LOS A            | 1.4               | 10.3   | 0.78      | 0.63           | 0.78                | 26.3        |
| West: Bathurst St (W)        |      |           |              |     |               |     |           |             |                  |                   |        |           |                |                     |             |
| 11                           | T1   | All MCs   | 1023         | 1.5 | 1023          | 1.5 | 0.382     | 3.6         | LOS A            | 3.2               | 22.5   | 0.34      | 0.30           | 0.34                | 29.5        |
| 12                           | R2   | All MCs   | 131          | 3.2 | 131           | 3.2 | *0.382    | 11.2        | LOS A            | 2.3               | 16.8   | 0.48      | 0.57           | 0.48                | 29.3        |
| Approach                     |      |           | 1154         | 1.7 | 1154          | 1.7 | 0.382     | 4.5         | LOS A            | 3.2               | 22.5   | 0.36      | 0.33           | 0.36                | 29.5        |
| All Vehicles                 |      |           | 1395         | 2.5 | 1395          | 2.5 | 0.382     | 6.1         | LOS A            | 3.2               | 22.5   | 0.43      | 0.38           | 0.43                | 28.4        |

Site Level of Service (LOS) Method: Delay (RTA NSW). Site LOS Method is specified in the Network Data dialog (Override Site Data tab).

Vehicle movement LOS values are based on average delay per movement.

Intersection and Approach LOS values are based on average delay for all vehicle movements.

Delay Model: SIDRA Standard (Control Delay: Geometric Delay is included).

Queue Model: SIDRA queue estimation methods are used for Back of Queue and Queue at Start of Green.

Gap-Acceptance Capacity Formula: SIDRA Standard (Akçelik M3D).

HV (%) values are calculated for All Movement Classes of All Heavy Vehicle Model Designation.

Arrival Flows used in performance calculations are adjusted to include any Initial Queued Demand and Upstream Capacity Constraint effects.

\* Critical Movement (Signal Timing)

| Pedestrian Movement Performance |          |           |             |                  |                       |        |           |                |             |              |             |
|---------------------------------|----------|-----------|-------------|------------------|-----------------------|--------|-----------|----------------|-------------|--------------|-------------|
| Mov ID                          | Crossing | Dem. Flow | Aver. Delay | Level of Service | AVERAGE BACK OF QUEUE |        | Prop. Que | Eff. Stop Rate | Travel Time | Travel Dist. | Aver. Speed |
|                                 |          | ped/h     | sec         |                  | [ Ped                 | Dist ] |           |                | sec         | m            | m/sec       |
|                                 |          |           |             |                  | ped                   | m      |           |                |             |              |             |
| South: Castlereagh St (S)       |          |           |             |                  |                       |        |           |                |             |              |             |
| P1                              | Full     | 439       | 14.7        | LOS B            | 0.5                   | 0.5    | 0.81      | 0.81           | 31.3        | 20.0         | 0.64        |
| East: Bathurst St (E)           |          |           |             |                  |                       |        |           |                |             |              |             |
| P2                              | Full     | 140       | 12.2        | LOS B            | 0.1                   | 0.1    | 0.74      | 0.74           | 28.8        | 20.0         | 0.69        |
| North: Castlereagh St (N)       |          |           |             |                  |                       |        |           |                |             |              |             |
| P3                              | Full     | 224       | 16.2        | LOS B            | 0.2                   | 0.2    | 0.85      | 0.85           | 32.9        | 20.0         | 0.61        |
| West: Bathurst St (W)           |          |           |             |                  |                       |        |           |                |             |              |             |
| P4                              | Full     | 171       | 12.9        | LOS B            | 0.2                   | 0.2    | 0.76      | 0.76           | 29.6        | 20.0         | 0.68        |
| All Pedestrians                 |          | 974       | 14.4        | LOS B            | 0.5                   | 0.5    | 0.80      | 0.80           | 31.0        | 20.0         | 0.64        |

Level of Service (LOS) Method: SIDRA Pedestrian LOS Method (Based on Average Delay)

Pedestrian movement LOS values are based on average delay per pedestrian movement.

Intersection LOS value for Pedestrians is based on average delay for all pedestrian movements.

**SIDRA INTERSECTION 9.1 | Copyright © 2000-2022 Akcelik and Associates Pty Ltd | sidrasolutions.com**

Organisation: AECOM AUSTRALIA PTY LTD | Licence: NETWORK / Enterprise Level 1 | Processed: Friday, 14 July 2023 11:24:51 AM

Project: C:\Users\YeungMAECOMANZ-NAC-Sydney Metro-Sydney Metro C&SW Operational Monitoring - General\400\_Technical\432\_Traffic Analysis\SIDRA Modelling\01 Models (Geometry Only)\Block 1\Rev1\_Review\06 SM C&SW\_PIT (Block 1)\_PS.sip9

# MOVEMENT SUMMARY

Site: PIT03 [PIT03 Park St / Castlereagh St (Site Folder: Block 1 Model - 2023 Weekend Peak)]

Output produced by SIDRA INTERSECTION Version: 9.1.1.200

Network: PIT-N1 [PIT Network 1 (Network Folder: Block 1 Network - 2023 Weekend Peak)]

TCS 250

Site Category: (None)

Signals - EQUISAT (Fixed-Time/SCATS) Isolated Cycle Time = 90 seconds (Site User-Given Phase Times)

| Vehicle Movement Performance |      |           |                       |      |                       |      |           |             |                  |                   |               |           |                |                     |             |
|------------------------------|------|-----------|-----------------------|------|-----------------------|------|-----------|-------------|------------------|-------------------|---------------|-----------|----------------|---------------------|-------------|
| Mov ID                       | Turn | Mov Class | Demand Flows          |      | Arrival Flows         |      | Deg. Satn | Aver. Delay | Level of Service | 95% Back Of Queue |               | Prop. Que | Eff. Stop Rate | Aver. No. of Cycles | Aver. Speed |
|                              |      |           | [ Total HV ]<br>veh/h | %    | [ Total HV ]<br>veh/h | %    |           |             |                  | [ Veh. veh        | [ Dist ]<br>m |           |                |                     |             |
| East: Park St (E)            |      |           |                       |      |                       |      |           |             |                  |                   |               |           |                |                     |             |
| 4                            | L2   | All MCs   | 43                    | 2.4  | 43                    | 2.4  | 0.047     | 12.7        | LOS A            | 0.9               | 6.5           | 0.48      | 0.59           | 0.48                | 10.7        |
| 5                            | T1   | All MCs   | 465                   | 8.1  | 465                   | 8.1  | *0.481    | 10.2        | LOS A            | 10.5              | 74.9          | 0.58      | 0.51           | 0.58                | 12.5        |
| Approach                     |      |           | 508                   | 7.7  | 508                   | 7.7  | 0.481     | 10.4        | LOS A            | 10.5              | 74.9          | 0.57      | 0.52           | 0.57                | 12.3        |
| North: Castlereagh St (N)    |      |           |                       |      |                       |      |           |             |                  |                   |               |           |                |                     |             |
| 7                            | L2   | All MCs   | 101                   | 2.1  | 101                   | 2.1  | 0.209     | 31.3        | LOS C            | 3.5               | 24.8          | 0.82      | 0.73           | 0.82                | 18.2        |
| 8                            | T1   | All MCs   | 155                   | 5.4  | 155                   | 5.4  | *0.381    | 33.4        | LOS C            | 5.8               | 42.0          | 0.90      | 0.73           | 0.90                | 17.0        |
| 9                            | R2   | All MCs   | 69                    | 4.5  | 69                    | 4.5  | 0.507     | 48.1        | LOS D            | 3.1               | 22.7          | 0.99      | 0.77           | 0.99                | 13.1        |
| Approach                     |      |           | 325                   | 4.2  | 325                   | 4.2  | 0.507     | 35.9        | LOS C            | 5.8               | 42.0          | 0.89      | 0.74           | 0.89                | 16.4        |
| West: Park St (W)            |      |           |                       |      |                       |      |           |             |                  |                   |               |           |                |                     |             |
| 11                           | T1   | All MCs   | 105                   | 27.0 | 105                   | 27.0 | 0.151     | 8.7         | LOS A            | 2.3               | 16.9          | 0.51      | 0.46           | 0.51                | 20.8        |
| 12                           | R2   | All MCs   | 36                    | 8.8  | 36                    | 8.8  | *0.151    | 14.5        | LOS A            | 2.3               | 16.9          | 0.54      | 0.50           | 0.54                | 16.9        |
| Approach                     |      |           | 141                   | 22.4 | 141                   | 22.4 | 0.151     | 10.2        | LOS A            | 2.3               | 16.9          | 0.52      | 0.47           | 0.52                | 19.9        |
| All Vehicles                 |      |           | 975                   | 8.6  | 975                   | 8.6  | 0.507     | 18.9        | LOS B            | 10.5              | 74.9          | 0.67      | 0.59           | 0.67                | 15.7        |

Site Level of Service (LOS) Method: Delay (RTA NSW). Site LOS Method is specified in the Network Data dialog (Override Site Data tab).

Vehicle movement LOS values are based on average delay per movement.

Intersection and Approach LOS values are based on average delay for all vehicle movements.

Delay Model: SIDRA Standard (Control Delay: Geometric Delay is included).

Queue Model: SIDRA queue estimation methods are used for Back of Queue and Queue at Start of Green.

Gap-Acceptance Capacity Formula: SIDRA Standard (Akçelik M3D).

HV (%) values are calculated for All Movement Classes of All Heavy Vehicle Model Designation.

Arrival Flows used in performance calculations are adjusted to include any Initial Queued Demand and Upstream Capacity Constraint effects.

\* Critical Movement (Signal Timing)

| Pedestrian Movement Performance |          |           |             |                  |                       |        |           |                |             |              |             |
|---------------------------------|----------|-----------|-------------|------------------|-----------------------|--------|-----------|----------------|-------------|--------------|-------------|
| Mov ID                          | Crossing | Dem. Flow | Aver. Delay | Level of Service | AVERAGE BACK OF QUEUE |        | Prop. Que | Eff. Stop Rate | Travel Time | Travel Dist. | Aver. Speed |
|                                 |          | ped/h     | sec         |                  | [ Ped                 | Dist ] |           |                | sec         | m            | m/sec       |
|                                 |          |           |             |                  | ped                   | m      |           |                |             |              |             |
| South: Castlereagh St (S)       |          |           |             |                  |                       |        |           |                |             |              |             |
| P1                              | Full     | 579       | 39.2        | LOS D            | 1.4                   | 1.4    | 0.95      | 0.95           | 55.9        | 20.0         | 0.36        |
| East: Park St (E)               |          |           |             |                  |                       |        |           |                |             |              |             |
| P2                              | Full     | 222       | 33.2        | LOS D            | 0.5                   | 0.5    | 0.86      | 0.86           | 49.9        | 20.0         | 0.40        |
| North: Castlereagh St (N)       |          |           |             |                  |                       |        |           |                |             |              |             |
| P3                              | Full     | 304       | 36.0        | LOS D            | 0.7                   | 0.7    | 0.90      | 0.90           | 52.7        | 20.0         | 0.38        |
| West: Park St (W)               |          |           |             |                  |                       |        |           |                |             |              |             |
| P4                              | Full     | 492       | 33.6        | LOS D            | 1.1                   | 1.1    | 0.87      | 0.87           | 50.3        | 20.0         | 0.40        |
| All Pedestrians                 |          | 1597      | 36.1        | LOS D            | 1.4                   | 1.4    | 0.90      | 0.90           | 52.7        | 20.0         | 0.38        |

Level of Service (LOS) Method: SIDRA Pedestrian LOS Method (Based on Average Delay)

Pedestrian movement LOS values are based on average delay per pedestrian movement.

Intersection LOS value for Pedestrians is based on average delay for all pedestrian movements.

**SIDRA INTERSECTION 9.1 | Copyright © 2000-2022 Akcelik and Associates Pty Ltd | sidrasolutions.com**

Organisation: AECOM AUSTRALIA PTY LTD | Licence: NETWORK / Enterprise Level 1 | Processed: Friday, 14 July 2023 11:24:51 AM

Project: C:\Users\YeungMAECOMANZ-NAC-Sydney Metro-Sydney Metro C&SW Operational Monitoring - General\400\_Technical\432\_Traffic Analysis\SIDRA Modelling\01 Models (Geometry Only)\Block 1\Rev1\_Review\06 SM C&SW\_PIT (Block 1)\_PS.sip9

# MOVEMENT SUMMARY

Site: PIT04 [PIT04 Park St / Pitt St (Site Folder: Block 1 Model - 2023 Weekend Peak)]

Output produced by SIDRA INTERSECTION Version: 9.1.1.200

Network: PIT-N1 [PIT Network 1 (Network Folder: Block 1 Network - 2023 Weekend Peak)]

TCS 235

Site Category: (None)

Signals - EQUISAT (Fixed-Time/SCATS) Isolated Cycle Time = 90 seconds (Site User-Given Phase Times)

| Vehicle Movement Performance |      |           |                       |     |                       |     |           |             |                  |                   |             |           |                |                     |             |
|------------------------------|------|-----------|-----------------------|-----|-----------------------|-----|-----------|-------------|------------------|-------------------|-------------|-----------|----------------|---------------------|-------------|
| Mov ID                       | Turn | Mov Class | Demand Flows          |     | Arrival Flows         |     | Deg. Satn | Aver. Delay | Level of Service | 95% Back Of Queue |             | Prop. Que | Eff. Stop Rate | Aver. No. of Cycles | Aver. Speed |
|                              |      |           | [ Total HV ]<br>veh/h | %   | [ Total HV ]<br>veh/h | %   |           |             |                  | [ Veh. veh        | Dist ]<br>m |           |                |                     |             |
| South: Pitt St (S)           |      |           |                       |     |                       |     |           |             |                  |                   |             |           |                |                     |             |
| 1                            | L2   | All MCs   | 138                   | 1.5 | 138                   | 1.5 | *0.970    | 51.7        | LOS D            | 5.4               | 38.2        | 1.00      | 1.11           | 1.79                | 10.6        |
| 2                            | T1   | All MCs   | 226                   | 0.9 | 226                   | 0.9 | 0.401     | 21.7        | LOS B            | 4.5               | 31.6        | 0.82      | 0.68           | 0.82                | 28.6        |
| 3                            | R2   | All MCs   | 64                    | 1.6 | 64                    | 1.6 | 0.352     | 34.4        | LOS C            | 1.6               | 11.1        | 0.97      | 0.74           | 0.97                | 13.0        |
| Approach                     |      |           | 428                   | 1.2 | 428                   | 1.2 | 0.970     | 33.3        | LOS C            | 5.4               | 38.2        | 0.90      | 0.83           | 1.16                | 19.2        |
| East: Park St (E)            |      |           |                       |     |                       |     |           |             |                  |                   |             |           |                |                     |             |
| 5                            | T1   | All MCs   | 447                   | 8.9 | 447                   | 8.9 | 0.788     | 16.7        | LOS B            | 11.9              | 84.9        | 0.93      | 0.86           | 1.00                | 17.7        |
| 6                            | R2   | All MCs   | 87                    | 1.2 | 87                    | 1.2 | *0.788    | 20.7        | LOS B            | 11.9              | 84.9        | 0.95      | 0.89           | 1.03                | 23.8        |
| Approach                     |      |           | 535                   | 7.7 | 535                   | 7.7 | 0.788     | 17.4        | LOS B            | 11.9              | 84.9        | 0.93      | 0.86           | 1.01                | 19.1        |
| West: Park St (W)            |      |           |                       |     |                       |     |           |             |                  |                   |             |           |                |                     |             |
| 10                           | L2   | All MCs   | 100.                  |     | 100.                  |     | 0.079     | 17.4        | LOS B            | 0.4               | 5.8         | 0.66      | 0.50           | 0.66                | 28.5        |
| 11                           | T1   | All MCs   | 280.                  |     | 280.                  |     | 0.079     | 9.7         | LOS A            | 0.4               | 5.8         | 0.66      | 0.50           | 0.66                | 17.2        |
| Approach                     |      |           | 290.                  |     | 290.                  |     | 0.079     | 10.0        | LOS A            | 0.4               | 5.8         | 0.66      | 0.50           | 0.66                | 18.0        |
| All Vehicles                 |      |           | 993                   | 7.6 | 993                   | 7.6 | 0.970     | 24.0        | LOS B            | 11.9              | 84.9        | 0.91      | 0.84           | 1.06                | 19.1        |

Site Level of Service (LOS) Method: Delay (RTA NSW). Site LOS Method is specified in the Network Data dialog (Override Site Data tab).

Vehicle movement LOS values are based on average delay per movement.

Intersection and Approach LOS values are based on average delay for all vehicle movements.

Delay Model: SIDRA Standard (Control Delay: Geometric Delay is included).

Queue Model: SIDRA queue estimation methods are used for Back of Queue and Queue at Start of Green.

Gap-Acceptance Capacity Formula: SIDRA Standard (Akçelik M3D).

HV (%) values are calculated for All Movement Classes of All Heavy Vehicle Model Designation.

Arrival Flows used in performance calculations are adjusted to include any Initial Queued Demand and Upstream Capacity Constraint effects.

\* Critical Movement (Signal Timing)



| Pedestrian Movement Performance |          |           |             |                  |                       |        |           |                |             |              |             |
|---------------------------------|----------|-----------|-------------|------------------|-----------------------|--------|-----------|----------------|-------------|--------------|-------------|
| Mov ID                          | Crossing | Dem. Flow | Aver. Delay | Level of Service | AVERAGE BACK OF QUEUE |        | Prop. Que | Eff. Stop Rate | Travel Time | Travel Dist. | Aver. Speed |
|                                 |          | ped/h     | sec         |                  | [ Ped                 | Dist ] |           |                | sec         | m            | m/sec       |
|                                 |          |           |             |                  | ped                   | m      |           |                |             |              |             |
| South: Pitt St (S)              |          |           |             |                  |                       |        |           |                |             |              |             |
| P1                              | Full     | 900       | 16.8        | LOS B            | 1.1                   | 1.1    | 0.88      | 0.88           | 33.4        | 20.0         | 0.60        |
| East: Park St (E)               |          |           |             |                  |                       |        |           |                |             |              |             |
| P2                              | Full     | 667       | 13.4        | LOS B            | 0.7                   | 0.7    | 0.78      | 0.78           | 30.1        | 20.0         | 0.67        |
| North: Pitt St (N)              |          |           |             |                  |                       |        |           |                |             |              |             |
| P3                              | Full     | 340       | 18.1        | LOS B            | 0.4                   | 0.4    | 0.90      | 0.90           | 34.8        | 20.0         | 0.57        |
| West: Park St (W)               |          |           |             |                  |                       |        |           |                |             |              |             |
| P4                              | Full     | 881       | 12.7        | LOS B            | 1.0                   | 1.0    | 0.76      | 0.76           | 29.4        | 20.0         | 0.68        |
| All Pedestrians                 |          | 2788      | 14.9        | LOS B            | 1.1                   | 1.1    | 0.82      | 0.82           | 31.5        | 20.0         | 0.63        |

Level of Service (LOS) Method: SIDRA Pedestrian LOS Method (Based on Average Delay)

Pedestrian movement LOS values are based on average delay per pedestrian movement.

Intersection LOS value for Pedestrians is based on average delay for all pedestrian movements.

**SIDRA INTERSECTION 9.1 | Copyright © 2000-2022 Akcelik and Associates Pty Ltd | sidrasolutions.com**

Organisation: AECOM AUSTRALIA PTY LTD | Licence: NETWORK / Enterprise Level 1 | Processed: Friday, 14 July 2023 11:24:51 AM

Project: C:\Users\YeungMA\AECOM\ANZ-NAC-Sydney Metro-Sydney Metro C&SW Operational Monitoring - General\400\_Technical\432\_Traffic Analysis\SIDRA Modelling\01 Models (Geometry Only)\Block 1\Rev1\_Review\06 SM C&SW\_PIT (Block 1)\_PS.sip9

# CCG MOVEMENT SUMMARY

Common Control Group: CCG1 [CEN-N1]

Output produced by SIDRA INTERSECTION Version: 9.1.1.200

Network: CEN-N1 [CEN Network 1 (Network Folder: Block 1 Network - 2023 AM Peak)]

EQUISAT (Fixed-Time/SCATS) Isolated Cycle Time = 108 seconds (CCG User-Given Phase Times)

| Vehicle Movement Performance (CCG)            |      |           |              |      |               |      |           |             |                  |                   |        |           |                |                     |             |
|---|------|-----------|--------------|------|---------------|------|-----------|-------------|------------------|-------------------|--------|-----------|----------------|---------------------|-------------|
| Mov ID  | Turn | Mov Class | Demand Flows |      | Arrival Flows |      | Deg. Satn | Aver. Delay | Level of Service | 95% Back Of Queue |        | Prop. Que | Eff. Stop Rate | Aver. No. of Cycles | Aver. Speed |
|   |      |           | [ Total HV ] | %    | [ Total HV ]  | %    |           |             |                  | [ Veh. veh        | Dist ] |           |                |                     |             |
|   |      |           | veh/h        |      | veh/h         | %    | v/c       | sec         |                  | m                 |        |           |                |                     | km/h        |
| Site: CEN01 [CEN01 Elizabeth St / Eddy Ave]   |      |           |              |      |               |      |           |             |                  |                   |        |           |                |                     |             |
| South: Elizabeth St (S)                       |      |           |              |      |               |      |           |             |                  |                   |        |           |                |                     |             |
| 1a  | L1   | All MCs   | 340          | 5.6  | 340           | 5.6  | 0.311     | 2.1         | LOS A            | 0.8               | 6.3    | 0.06      | 0.34           | 0.06                | 30.8        |
| 2   | T1   | All MCs   | 1123         | 7.3  | 1123          | 7.3  | *0.649    | 8.4         | LOS A            | 7.9               | 57.1   | 0.55      | 0.55           | 0.55                | 25.0        |
| Approach                                      |      |           | 1463         | 6.9  | 1463          | 6.9  | 0.649     | 7.0         | LOS A            | 7.9               | 57.1   | 0.44      | 0.50           | 0.44                | 25.8        |
| North: Elizabeth St (N)                       |      |           |              |      |               |      |           |             |                  |                   |        |           |                |                     |             |
| 8   | T1   | All MCs   | 493          | 10.3 | 493           | 10.3 | *0.833    | 39.2        | LOS C            | 25.2              | 185.7  | 0.96      | 0.94           | 1.08                | 8.8         |
| 9b  | R3   | All MCs   | 208          | 18.7 | 208           | 18.7 | 0.548     | 53.1        | LOS D            | 5.4               | 43.6   | 0.98      | 0.79           | 0.98                | 9.6         |
| Approach                                      |      |           | 701          | 12.8 | 701           | 12.8 | 0.833     | 43.3        | LOS D            | 25.2              | 185.7  | 0.97      | 0.90           | 1.05                | 9.1         |
| NorthWest: Eddy Ave (NW)                      |      |           |              |      |               |      |           |             |                  |                   |        |           |                |                     |             |
| 27b   | L3   | All MCs   | 707          | 8.5  | 707           | 8.5  | *0.981    | 72.6        | LOS F            | 20.9              | 157.2  | 1.00      | 1.27           | 1.56                | 7.7         |
| 29a   | R1   | All MCs   | 156          | 10.8 | 156           | 10.8 | 0.892     | 66.4        | LOS E            | 9.5               | 72.9   | 1.00      | 1.11           | 1.41                | 3.5         |
| Approach                                      |      |           | 863          | 8.9  | 863           | 8.9  | 0.981     | 71.5        | LOS F            | 20.9              | 157.2  | 1.00      | 1.24           | 1.53                | 7.1         |
| All Vehicles                                  |      |           | 3027         | 8.8  | 3027          | 8.8  | 0.981     | 33.8        | LOS C            | 25.2              | 185.7  | 0.72      | 0.81           | 0.89                | 11.5        |
| Site: CEN02 [CEN02 Elizabeth St / Foveaux St] |      |           |              |      |               |      |           |             |                  |                   |        |           |                |                     |             |
| South: Elizabeth St (S)                       |      |           |              |      |               |      |           |             |                  |                   |        |           |                |                     |             |
| 2   | T1   | All MCs   | 961          | 8.0  | 961           | 8.0  | 0.719     | 31.5        | LOS C            | 21.8              | 162.8  | 0.92      | 0.81           | 0.92                | 12.0        |
| Approach                                      |      |           | 961          | 8.0  | 961           | 8.0  | 0.719     | 31.5        | LOS C            | 21.8              | 162.8  | 0.92      | 0.81           | 0.92                | 12.0        |
| SouthEast: Foveaux St (SE)                    |      |           |              |      |               |      |           |             |                  |                   |        |           |                |                     |             |
| 21b   | L3   | All MCs   | 151          | 2.1  | 151           | 2.1  | 0.284     | 32.7        | LOS C            | 5.9               | 41.7   | 0.78      | 0.75           | 0.78                | 17.2        |
| 23a   | R1   | All MCs   | 502          | 4.8  | 502           | 4.8  | 0.608     | 26.9        | LOS B            | 10.2              | 74.4   | 0.81      | 0.78           | 0.81                | 12.3        |
| Approach                                      |      |           | 653          | 4.2  | 653           | 4.2  | 0.608     | 28.2        | LOS B            | 10.2              | 74.4   | 0.80      | 0.77           | 0.80                | 13.8        |
| North: Elizabeth St (N)                       |      |           |              |      |               |      |           |             |                  |                   |        |           |                |                     |             |
| 8   | T1   | All MCs   | 648          | 10.4 | 648           | 10.4 | 0.403     | 10.0        | LOS A            | 7.8               | 57.1   | 0.34      | 0.29           | 0.34                | 25.1        |
| Approach                                      |      |           | 648          | 10.4 | 648           | 10.4 | 0.403     | 10.0        | LOS A            | 7.8               | 57.1   | 0.34      | 0.29           | 0.34                | 25.1        |
| All Vehicles                                  |      |           | 2262         | 7.6  | 2262          | 7.6  | 0.719     | 24.4        | LOS B            | 21.8              | 162.8  | 0.72      | 0.65           | 0.72                | 15.1        |

Site Level of Service (LOS) Method: Delay (RTA NSW). Site LOS Method is specified in the Network Data dialog (Override Site Data tab).

Vehicle movement LOS values are based on average delay per movement.

Intersection and Approach LOS values are based on average delay for all vehicle movements.

Delay Model: SIDRA Standard (Control Delay: Geometric Delay is included).

Gap-Acceptance Capacity Formula: SIDRA Standard (Akçelik M3D).

HV (%) values are calculated for All Movement Classes of All Heavy Vehicle Model Designation.

Arrival Flows used in performance calculations are adjusted to include any Initial Queued Demand and Upstream Capacity Constraint effects.

\* Critical Movement (Signal Timing)

---

**SIDRA INTERSECTION 9.1 | Copyright © 2000-2022 Akcelik and Associates Pty Ltd | sidrasolutions.com**

Organisation: AECOM AUSTRALIA PTY LTD | Licence: NETWORK / Enterprise Level 1 | Processed: Friday, 14 July 2023 4:22:01 PM

Project: C:\Users\Yeung\AECOMANZ-NAC-Sydney Metro-Sydney Metro C&SW Operational Monitoring - General\400\_Technical\432\_Traffic Analysis\SIDRA Modelling\01 Models (Geometry Only)\Block 1\Rev1\Test\07 SM C&SW\_CEN (Block 1)\_PS\_TEST.sip9

# MOVEMENT SUMMARY

Site: CEN03 [CEN03 Elizabeth St / Cooper St (Site Folder: Block 1 Model - 2023 AM Peak)]

Output produced by SIDRA INTERSECTION Version: 9.1.1.200

Network: CEN-N2 [CEN Network 2 (Network Folder: Block 1 Network - 2023 AM Peak)]

NA  
 Site Category: (None)  
 Give-Way (Two-Way)

| Vehicle Movement Performance |      |           |                       |      |                       |      |           |             |                  |                   |               |           |                |                     |             |
|------------------------------|------|-----------|-----------------------|------|-----------------------|------|-----------|-------------|------------------|-------------------|---------------|-----------|----------------|---------------------|-------------|
| Mov ID                       | Turn | Mov Class | Demand Flows          |      | Arrival Flows         |      | Deg. Satn | Aver. Delay | Level of Service | 95% Back Of Queue |               | Prop. Que | Eff. Stop Rate | Aver. No. of Cycles | Aver. Speed |
|                              |      |           | [ Total HV ]<br>veh/h | %    | [ Total HV ]<br>veh/h | %    |           |             |                  | [ Veh. veh        | [ Dist ]<br>m |           |                |                     |             |
| SouthEast: Cooper St (SE)    |      |           |                       |      |                       |      |           |             |                  |                   |               |           |                |                     |             |
| 21b                          | L3   | All MCs   | 89                    | 4.7  | 89                    | 4.7  | 0.090     | 6.2         | LOS A            | 0.4               | 2.7           | 0.48      | 0.64           | 0.48                | 33.7        |
| Approach                     |      |           | 89                    | 4.7  | 89                    | 4.7  | 0.090     | 6.2         | LOS A            | 0.4               | 2.7           | 0.48      | 0.64           | 0.48                | 33.7        |
| North: Elizabeth St (N)      |      |           |                       |      |                       |      |           |             |                  |                   |               |           |                |                     |             |
| 7a                           | L1   | All MCs   | 67                    | 3.1  | 67                    | 3.1  | 0.156     | 5.0         | LOS A            | 0.5               | 4.0           | 0.24      | 0.26           | 0.24                | 36.5        |
| 8                            | T1   | All MCs   | 705                   | 12.5 | 705                   | 12.5 | 0.156     | 0.0         | LOS A            | 0.5               | 4.0           | 0.06      | 0.06           | 0.06                | 38.8        |
| Approach                     |      |           | 773                   | 11.7 | 773                   | 11.7 | 0.156     | 0.4         | NA               | 0.5               | 4.0           | 0.07      | 0.08           | 0.07                | 38.3        |
| All Vehicles                 |      |           | 862                   | 11.0 | 862                   | 11.0 | 0.156     | 1.0         | NA               | 0.5               | 4.0           | 0.11      | 0.14           | 0.11                | 37.0        |

Site Level of Service (LOS) Method: Delay (RTA NSW). Site LOS Method is specified in the Network Data dialog (Override Site Data tab).

Vehicle movement LOS values are based on average delay per movement.

Minor Road Approach LOS values are based on average delay for all vehicle movements.

NA (TWSC): Level of Service is not defined for major road approaches or the intersection as a whole for Two-Way Sign Control (HCM LOS rule).

Two-Way Sign Control Capacity Model: SIDRA Standard.

Delay Model: SIDRA Standard (Control Delay: Geometric Delay is included).

Queue Model: SIDRA queue estimation methods are used for Back of Queue and Queue at Start of Gap.

Gap-Acceptance Capacity Formula: SIDRA Standard (Akçelik M3D).

HV (%) values are calculated for All Movement Classes of All Heavy Vehicle Model Designation.

Arrival Flows used in performance calculations are adjusted to include any Initial Queued Demand and Upstream Capacity Constraint effects.

---

**SIDRA INTERSECTION 9.1 | Copyright © 2000-2022 Akcelik and Associates Pty Ltd | sidrasolutions.com**

Organisation: AECOM AUSTRALIA PTY LTD | Licence: NETWORK / Enterprise Level 1 | Processed: Friday, 14 July 2023 3:32:52 PM

Project: C:\Users\Yeung\AECOM\ANZ-NAC-Sydney Metro-Sydney Metro C&SW Operational Monitoring - General\400\_Technical\432\_Traffic Analysis\SIDRA Modelling\01 Models (Geometry Only)\Block 1\Rev1\Test\07 SM C&SW\_CEN (Block 1)\_PS\_TEST.sip9

# MOVEMENT SUMMARY

Site: CEN05 [CEN05 Elizabeth St / Randle St (Site Folder: Block 1 Model - 2023 AM Peak)]

Output produced by SIDRA INTERSECTION Version: 9.1.1.200

Network: CEN-N2 [CEN Network 2 (Network Folder: Block 1 Network - 2023 AM Peak)]

TCS 2916

Site Category: (None)

Signals - EQUISAT (Fixed-Time/SCATS) Isolated Cycle Time = 110 seconds (Site User-Given Phase Times)

| Vehicle Movement Performance |      |           |                       |      |                       |      |           |             |                  |                   |               |           |                |                     |                  |
|------------------------------|------|-----------|-----------------------|------|-----------------------|------|-----------|-------------|------------------|-------------------|---------------|-----------|----------------|---------------------|------------------|
| Mov ID                       | Turn | Mov Class | Demand Flows          |      | Arrival Flows         |      | Deg. Satn | Aver. Delay | Level of Service | 95% Back Of Queue |               | Prop. Que | Eff. Stop Rate | Aver. No. of Cycles | Aver. Speed km/h |
|                              |      |           | [ Total HV ]<br>veh/h | %    | [ Total HV ]<br>veh/h | %    |           |             |                  | [ Veh. veh        | [ Dist ]<br>m |           |                |                     |                  |
| North: Elizabeth St (N)      |      |           |                       |      |                       |      |           |             |                  |                   |               |           |                |                     |                  |
| 8                            | T1   | All MCs   | 700                   | 11.4 | 700                   | 11.4 | 0.247     | 2.6         | LOS A            | 4.4               | 33.7          | 0.26      | 0.23           | 0.26                | 33.5             |
| Approach                     |      |           | 700                   | 11.4 | 700                   | 11.4 | 0.247     | 2.6         | LOS A            | 4.4               | 33.7          | 0.26      | 0.23           | 0.26                | 33.5             |
| SouthWest: Randle St (SW)    |      |           |                       |      |                       |      |           |             |                  |                   |               |           |                |                     |                  |
| 30a                          | L1   | All MCs   | 1058                  | 8.1  | 1058                  | 8.1  | * 0.705   | 30.8        | LOS C            | 22.6              | 169.0         | 0.76      | 0.78           | 0.76                | 20.6             |
| 32b                          | R3   | All MCs   | 73                    | 14.5 | 73                    | 14.5 | * 0.705   | 5.3         | LOS A            | 16.2              | 122.5         | 0.78      | 0.81           | 0.78                | 13.5             |
| Approach                     |      |           | 1131                  | 8.5  | 1131                  | 8.5  | 0.705     | 29.1        | LOS C            | 22.6              | 169.0         | 0.76      | 0.78           | 0.76                | 20.3             |
| All Vehicles                 |      |           | 1831                  | 9.6  | 1831                  | 9.6  | 0.705     | 19.0        | LOS B            | 22.6              | 169.0         | 0.57      | 0.57           | 0.57                | 22.7             |

Site Level of Service (LOS) Method: Delay (RTA NSW). Site LOS Method is specified in the Network Data dialog (Override Site Data tab).

Vehicle movement LOS values are based on average delay per movement.

Intersection and Approach LOS values are based on average delay for all vehicle movements.

Delay Model: SIDRA Standard (Control Delay: Geometric Delay is included).

Queue Model: SIDRA queue estimation methods are used for Back of Queue and Queue at Start of Green.

Gap-Acceptance Capacity Formula: SIDRA Standard (Akçelik M3D).

HV (%) values are calculated for All Movement Classes of All Heavy Vehicle Model Designation.

Arrival Flows used in performance calculations are adjusted to include any Initial Queued Demand and Upstream Capacity Constraint effects.

\* Critical Movement (Signal Timing)

| Pedestrian Movement Performance |          |           |             |                  |                       |        |           |                |             |              |             |
|---------------------------------|----------|-----------|-------------|------------------|-----------------------|--------|-----------|----------------|-------------|--------------|-------------|
| Mov ID                          | Crossing | Dem. Flow | Aver. Delay | Level of Service | AVERAGE BACK OF QUEUE |        | Prop. Que | Eff. Stop Rate | Travel Time | Travel Dist. | Aver. Speed |
|                                 |          | ped/h     | sec         |                  | [ Ped                 | Dist ] |           |                | sec         | m            | m/sec       |
|                                 |          |           |             |                  | ped                   | m      |           |                |             |              |             |
| South: Elizabeth St (S)         |          |           |             |                  |                       |        |           |                |             |              |             |
| P1                              | Full     | 407       | 49.1        | LOS E            | 1.2                   | 1.2    | 0.95      | 0.95           | 215.7       | 200.0        | 0.93        |
| SouthWest: Randle St (SW)       |          |           |             |                  |                       |        |           |                |             |              |             |
| P8                              | Full     | 287       | 45.1        | LOS E            | 0.8                   | 0.8    | 0.91      | 0.91           | 211.8       | 200.0        | 0.94        |
| All Pedestrians                 |          | 695       | 47.4        | LOS E            | 1.2                   | 1.2    | 0.94      | 0.94           | 214.1       | 200.0        | 0.93        |

Level of Service (LOS) Method: SIDRA Pedestrian LOS Method (Based on Average Delay)

Pedestrian movement LOS values are based on average delay per pedestrian movement.

Intersection LOS value for Pedestrians is based on average delay for all pedestrian movements.

---

**SIDRA INTERSECTION 9.1 | Copyright © 2000-2022 Akcelik and Associates Pty Ltd | sidrasolutions.com**

Organisation: AECOM AUSTRALIA PTY LTD | Licence: NETWORK / Enterprise Level 1 | Processed: Friday, 14 July 2023 3:32:52 PM

Project: C:\Users\YeungM\AECOM\ANZ-NAC-Sydney Metro-Sydney Metro C&SW Operational Monitoring - General\400\_Technical\432\_Traffic Analysis\SIDRA Modelling\01 Models (Geometry Only)\Block 1\Rev1\Test\07 SM C&SW\_CEN (Block 1)\_PS\_TEST.sip9

# CCG MOVEMENT SUMMARY

Common Control Group: CCG1 [CCGName]

Output produced by SIDRA INTERSECTION Version: 9.1.1.200

Network: CEN-N1 [CEN Network 1 (Network Folder: Block 1 Network - 2023 PM Peak)]

EQUISAT (Fixed-Time/SCATS) Isolated Cycle Time = 110 seconds (CCG User-Given Phase Times)

| Vehicle Movement Performance (CCG)            |      |           |              |      |               |      |           |             |                  |                   |           |                |                     |             |      |
|---|------|-----------|--------------|------|---------------|------|-----------|-------------|------------------|-------------------|-----------|----------------|---------------------|-------------|------|
| Mov ID  | Turn | Mov Class | Demand Flows |      | Arrival Flows |      | Deg. Satn | Aver. Delay | Level of Service | 95% Back Of Queue | Prop. Que | Eff. Stop Rate | Aver. No. of Cycles | Aver. Speed |      |
|   |      |           | [ Total HV ] | %    | [ Total HV ]  | %    | v/c       | sec         |                  | [ Veh. veh        | Dist ] m  |                |                     | km/h        |      |
| Site: CEN01 [CEN01 Elizabeth St / Eddy Ave]   |      |           |              |      |               |      |           |             |                  |                   |           |                |                     |             |      |
| South: Elizabeth St (S)                       |      |           |              |      |               |      |           |             |                  |                   |           |                |                     |             |      |
| 1a  | L1   | All MCs   | 466          | 0.7  | 466           | 0.7  | 0.400     | 2.7         | LOS A            | 3.0               | 22.2      | 0.16           | 0.42                | 0.16        | 29.0 |
| 2   | T1   | All MCs   | 917          | 4.4  | 917           | 4.4  | *0.548    | 11.3        | LOS A            | 8.1               | 57.1      | 0.64           | 0.60                | 0.64        | 22.3 |
| Approach                                      |      |           | 1383         | 3.1  | 1383          | 3.1  | 0.548     | 8.4         | LOS A            | 8.1               | 57.1      | 0.47           | 0.54                | 0.47        | 23.7 |
| North: Elizabeth St (N)                       |      |           |              |      |               |      |           |             |                  |                   |           |                |                     |             |      |
| 8   | T1   | All MCs   | 620          | 5.9  | 620           | 5.9  | *0.779    | 36.9        | LOS C            | 29.2              | 207.7     | 0.96           | 0.86                | 0.98        | 9.2  |
| 9b  | R3   | All MCs   | 359          | 10.0 | 359           | 10.0 | 0.636     | 49.8        | LOS D            | 9.2               | 69.9      | 0.97           | 0.83                | 0.99        | 10.1 |
| Approach                                      |      |           | 979          | 7.4  | 979           | 7.4  | 0.779     | 41.6        | LOS C            | 29.2              | 207.7     | 0.97           | 0.85                | 0.98        | 9.6  |
| NorthWest: Eddy Ave (NW)                      |      |           |              |      |               |      |           |             |                  |                   |           |                |                     |             |      |
| 27b   | L3   | All MCs   | 716          | 4.6  | 716           | 4.6  | *0.792    | 30.8        | LOS C            | 13.8              | 100.4     | 0.98           | 0.91                | 1.08        | 14.3 |
| 29a   | R1   | All MCs   | 160          | 11.2 | 160           | 11.2 | *0.936    | 74.6        | LOS F            | 10.6              | 81.0      | 1.00           | 1.20                | 1.53        | 3.1  |
| Approach                                      |      |           | 876          | 5.8  | 876           | 5.8  | 0.936     | 38.8        | LOS C            | 13.8              | 100.4     | 0.98           | 0.96                | 1.16        | 11.3 |
| All Vehicles                                  |      |           | 3238         | 5.1  | 3238          | 5.1  | 0.936     | 26.7        | LOS B            | 29.2              | 207.7     | 0.76           | 0.75                | 0.81        | 13.4 |
| Site: CEN02 [CEN02 Elizabeth St / Foveaux St] |      |           |              |      |               |      |           |             |                  |                   |           |                |                     |             |      |
| South: Elizabeth St (S)                       |      |           |              |      |               |      |           |             |                  |                   |           |                |                     |             |      |
| 2   | T1   | All MCs   | 691          | 4.6  | 691           | 4.6  | 0.582     | 33.9        | LOS C            | 15.5              | 113.1     | 0.89           | 0.77                | 0.89        | 11.4 |
| Approach                                      |      |           | 691          | 4.6  | 691           | 4.6  | 0.582     | 33.9        | LOS C            | 15.5              | 113.1     | 0.89           | 0.77                | 0.89        | 11.4 |
| SouthEast: Foveaux St (SE)                    |      |           |              |      |               |      |           |             |                  |                   |           |                |                     |             |      |
| 21b   | L3   | All MCs   | 198          | 2.1  | 198           | 2.1  | 0.318     | 29.2        | LOS C            | 7.4               | 52.6      | 0.74           | 0.75                | 0.74        | 18.3 |
| 23a   | R1   | All MCs   | 693          | 1.7  | 693           | 1.7  | 0.890     | 51.6        | LOS D            | 22.7              | 161.1     | 0.97           | 1.07                | 1.27        | 7.5  |
| Approach                                      |      |           | 891          | 1.8  | 891           | 1.8  | 0.890     | 46.6        | LOS D            | 22.7              | 161.1     | 0.92           | 1.00                | 1.15        | 9.7  |
| North: Elizabeth St (N)                       |      |           |              |      |               |      |           |             |                  |                   |           |                |                     |             |      |
| 8   | T1   | All MCs   | 780          | 7.0  | 780           | 7.0  | 0.529     | 9.6         | LOS A            | 8.0               | 57.1      | 0.34           | 0.29                | 0.34        | 25.5 |
| Approach                                      |      |           | 780          | 7.0  | 780           | 7.0  | 0.529     | 9.6         | LOS A            | 8.0               | 57.1      | 0.34           | 0.29                | 0.34        | 25.5 |
| All Vehicles                                  |      |           | 2361         | 4.3  | 2361          | 4.3  | 0.890     | 30.7        | LOS C            | 22.7              | 161.1     | 0.72           | 0.70                | 0.81        | 13.2 |

Site Level of Service (LOS) Method: Delay (RTA NSW). Site LOS Method is specified in the Network Data dialog (Override Site Data tab).

Vehicle movement LOS values are based on average delay per movement.

Intersection and Approach LOS values are based on average delay for all vehicle movements.

Delay Model: SIDRA Standard (Control Delay: Geometric Delay is included).

Gap-Acceptance Capacity Formula: SIDRA Standard (Akçelik M3D).

HV (%) values are calculated for All Movement Classes of All Heavy Vehicle Model Designation.

Arrival Flows used in performance calculations are adjusted to include any Initial Queued Demand and Upstream Capacity Constraint effects.

\* Critical Movement (Signal Timing)



---

**SIDRA INTERSECTION 9.1 | Copyright © 2000-2022 Akcelik and Associates Pty Ltd | sidrasolutions.com**

Organisation: AECOM AUSTRALIA PTY LTD | Licence: NETWORK / Enterprise Level 1 | Processed: Friday, 14 July 2023 4:33:49 PM

Project: C:\Users\Yeung\AECOM\ANZ-NAC-Sydney Metro-Sydney Metro C&SW Operational Monitoring - General\400\_Technical\432\_Traffic Analysis\SIDRA Modelling\01 Models (Geometry Only)\Block 1\Rev1\Test\07 SM C&SW\_CEN (Block 1)\_PS\_TEST.sip9

# MOVEMENT SUMMARY

Site: CEN03 [CEN03 Elizabeth St / Cooper St (Site Folder: Block 1 Model - 2023 PM Peak)]

Output produced by SIDRA INTERSECTION Version: 9.1.1.200

Network: CEN-N2 [CEN Network 2 (Network Folder: Block 1 Network - 2023 PM Peak)]

NA

Site Category: (None)

Give-Way (Two-Way)

| Vehicle Movement Performance |      |           |                       |     |                       |     |           |             |                  |                   |               |           |                |                     |             |
|------------------------------|------|-----------|-----------------------|-----|-----------------------|-----|-----------|-------------|------------------|-------------------|---------------|-----------|----------------|---------------------|-------------|
| Mov ID                       | Turn | Mov Class | Demand Flows          |     | Arrival Flows         |     | Deg. Satn | Aver. Delay | Level of Service | 95% Back Of Queue |               | Prop. Que | Eff. Stop Rate | Aver. No. of Cycles | Aver. Speed |
|                              |      |           | [ Total HV ]<br>veh/h | %   | [ Total HV ]<br>veh/h | %   |           |             |                  | [ Veh. veh        | [ Dist ]<br>m |           |                |                     |             |
| SouthEast: Cooper St (SE)    |      |           |                       |     |                       |     |           |             |                  |                   |               |           |                |                     |             |
| 21b                          | L3   | All MCs   | 94                    | 1.1 | 94                    | 1.1 | 0.101     | 6.6         | LOSA             | 0.4               | 2.9           | 0.52      | 0.68           | 0.52                | 33.4        |
| Approach                     |      |           | 94                    | 1.1 | 94                    | 1.1 | 0.101     | 6.6         | LOSA             | 0.4               | 2.9           | 0.52      | 0.68           | 0.52                | 33.4        |
| North: Elizabeth St (N)      |      |           |                       |     |                       |     |           |             |                  |                   |               |           |                |                     |             |
| 7a                           | L1   | All MCs   | 74                    | 0.0 | 74                    | 0.0 | 0.199     | 5.4         | LOSA             | 0.6               | 4.5           | 0.21      | 0.23           | 0.21                | 36.8        |
| 8                            | T1   | All MCs   | 977                   | 5.5 | 977                   | 5.5 | 0.199     | 0.0         | LOSA             | 0.6               | 4.5           | 0.05      | 0.06           | 0.05                | 38.9        |
| Approach                     |      |           | 1051                  | 5.1 | 1051                  | 5.1 | 0.199     | 0.4         | NA               | 0.6               | 4.5           | 0.06      | 0.07           | 0.06                | 38.5        |
| All Vehicles                 |      |           | 1144                  | 4.8 | 1144                  | 4.8 | 0.199     | 0.9         | NA               | 0.6               | 4.5           | 0.10      | 0.12           | 0.10                | 37.3        |

Site Level of Service (LOS) Method: Delay (RTA NSW). Site LOS Method is specified in the Network Data dialog (Override Site Data tab).

Vehicle movement LOS values are based on average delay per movement.

Minor Road Approach LOS values are based on average delay for all vehicle movements.

NA (TWSC): Level of Service is not defined for major road approaches or the intersection as a whole for Two-Way Sign Control (HCM LOS rule).

Two-Way Sign Control Capacity Model: SIDRA Standard.

Delay Model: SIDRA Standard (Control Delay: Geometric Delay is included).

Queue Model: SIDRA queue estimation methods are used for Back of Queue and Queue at Start of Gap.

Gap-Acceptance Capacity Formula: SIDRA Standard (Akçelik M3D).

HV (%) values are calculated for All Movement Classes of All Heavy Vehicle Model Designation.

Arrival Flows used in performance calculations are adjusted to include any Initial Queued Demand and Upstream Capacity Constraint effects.

---

**SIDRA INTERSECTION 9.1 | Copyright © 2000-2022 Akcelik and Associates Pty Ltd | sidrasolutions.com**

Organisation: AECOM AUSTRALIA PTY LTD | Licence: NETWORK / Enterprise Level 1 | Processed: Friday, 14 July 2023 3:32:56 PM

Project: C:\Users\Yeung\AECOM\ANZ-NAC-Sydney Metro-Sydney Metro C&SW Operational Monitoring - General\400\_Technical\432\_Traffic Analysis\SIDRA Modelling\01 Models (Geometry Only)\Block 1\Rev1\Test\07 SM C&SW\_CEN (Block 1)\_PS\_TEST.sip9

# MOVEMENT SUMMARY

Site: CEN05 [CEN05 Elizabeth St / Randle St (Site Folder: Block 1 Model - 2023 PM Peak)]

Output produced by SIDRA INTERSECTION Version: 9.1.1.200

Network: CEN-N2 [CEN Network 2 (Network Folder: Block 1 Network - 2023 PM Peak)]

TCS 2916

Site Category: (None)

Signals - EQUISAT (Fixed-Time/SCATS) Isolated Cycle Time = 110 seconds (Site User-Given Phase Times)

| Vehicle Movement Performance |      |           |                       |     |                       |     |           |             |                  |                   |               |           |                |                     |                  |
|------------------------------|------|-----------|-----------------------|-----|-----------------------|-----|-----------|-------------|------------------|-------------------|---------------|-----------|----------------|---------------------|------------------|
| Mov ID                       | Turn | Mov Class | Demand Flows          |     | Arrival Flows         |     | Deg. Satn | Aver. Delay | Level of Service | 95% Back Of Queue |               | Prop. Que | Eff. Stop Rate | Aver. No. of Cycles | Aver. Speed km/h |
|                              |      |           | [ Total HV ]<br>veh/h | %   | [ Total HV ]<br>veh/h | %   |           |             |                  | [ Veh. veh        | [ Dist ]<br>m |           |                |                     |                  |
| North: Elizabeth St (N)      |      |           |                       |     |                       |     |           |             |                  |                   |               |           |                |                     |                  |
| 8                            | T1   | All MCs   | 985                   | 5.3 | 985                   | 5.3 | 0.329     | 2.9         | LOS A            | 6.7               | 49.2          | 0.28      | 0.25           | 0.28                | 33.0             |
| Approach                     |      |           | 985                   | 5.3 | 985                   | 5.3 | 0.329     | 2.9         | LOS A            | 6.7               | 49.2          | 0.28      | 0.25           | 0.28                | 33.0             |
| SouthWest: Randle St (SW)    |      |           |                       |     |                       |     |           |             |                  |                   |               |           |                |                     |                  |
| 30a                          | L1   | All MCs   | 798                   | 4.7 | 798                   | 4.7 | * 0.502   | 24.8        | LOS B            | 14.6              | 106.6         | 0.65      | 0.72           | 0.65                | 22.0             |
| 32b                          | R3   | All MCs   | 65                    | 1.6 | 65                    | 1.6 | * 0.502   | 5.1         | LOS A            | 10.2              | 74.0          | 0.65      | 0.74           | 0.65                | 15.1             |
| Approach                     |      |           | 863                   | 4.5 | 863                   | 4.5 | 0.502     | 23.3        | LOS B            | 14.6              | 106.6         | 0.65      | 0.72           | 0.65                | 21.6             |
| All Vehicles                 |      |           | 1848                  | 5.0 | 1848                  | 5.0 | 0.502     | 12.4        | LOS A            | 14.6              | 106.6         | 0.45      | 0.47           | 0.45                | 25.1             |

Site Level of Service (LOS) Method: Delay (RTA NSW). Site LOS Method is specified in the Network Data dialog (Override Site Data tab).

Vehicle movement LOS values are based on average delay per movement.

Intersection and Approach LOS values are based on average delay for all vehicle movements.

Delay Model: SIDRA Standard (Control Delay: Geometric Delay is included).

Queue Model: SIDRA queue estimation methods are used for Back of Queue and Queue at Start of Green.

Gap-Acceptance Capacity Formula: SIDRA Standard (Akçelik M3D).

HV (%) values are calculated for All Movement Classes of All Heavy Vehicle Model Designation.

Arrival Flows used in performance calculations are adjusted to include any Initial Queued Demand and Upstream Capacity Constraint effects.

\* Critical Movement (Signal Timing)

| Pedestrian Movement Performance |          |           |             |                  |                       |        |           |                |             |              |             |
|---------------------------------|----------|-----------|-------------|------------------|-----------------------|--------|-----------|----------------|-------------|--------------|-------------|
| Mov ID                          | Crossing | Dem. Flow | Aver. Delay | Level of Service | AVERAGE BACK OF QUEUE |        | Prop. Que | Eff. Stop Rate | Travel Time | Travel Dist. | Aver. Speed |
|                                 |          | ped/h     | sec         |                  | [ Ped                 | Dist ] |           |                | sec         | m            | m/sec       |
|                                 |          |           |             |                  | ped                   | m      |           |                |             |              |             |
| South: Elizabeth St (S)         |          |           |             |                  |                       |        |           |                |             |              |             |
| P1                              | Full     | 389       | 49.0        | LOS E            | 1.2                   | 1.2    | 0.95      | 0.95           | 215.7       | 200.0        | 0.93        |
| SouthWest: Randle St (SW)       |          |           |             |                  |                       |        |           |                |             |              |             |
| P8                              | Full     | 312       | 45.1        | LOS E            | 0.9                   | 0.9    | 0.91      | 0.91           | 211.8       | 200.0        | 0.94        |
| All Pedestrians                 |          | 701       | 47.3        | LOS E            | 1.2                   | 1.2    | 0.93      | 0.93           | 214.0       | 200.0        | 0.93        |

Level of Service (LOS) Method: SIDRA Pedestrian LOS Method (Based on Average Delay)

Pedestrian movement LOS values are based on average delay per pedestrian movement.

Intersection LOS value for Pedestrians is based on average delay for all pedestrian movements.

---

**SIDRA INTERSECTION 9.1 | Copyright © 2000-2022 Akcelik and Associates Pty Ltd | sidrasolutions.com**

Organisation: AECOM AUSTRALIA PTY LTD | Licence: NETWORK / Enterprise Level 1 | Processed: Friday, 14 July 2023 3:32:56 PM

Project: C:\Users\YeungM\AECOM\ANZ-NAC-Sydney Metro-Sydney Metro C&SW Operational Monitoring - General\400\_Technical\432\_Traffic Analysis\SIDRA Modelling\01 Models (Geometry Only)\Block 1\Rev1\Test\07 SM C&SW\_CEN (Block 1)\_PS\_TEST.sip9

# CCG MOVEMENT SUMMARY

Common Control Group: CCG1 [CCGName]

Output produced by SIDRA INTERSECTION Version: 9.1.1.200

Network: CEN-N1 [CEN Network 1 (Network Folder: Block 1 Network - 2023 Weekend Peak)]

EQUISAT (Fixed-Time/SCATS) Isolated Cycle Time = 112 seconds (CCG User-Given Phase Times)

| Vehicle Movement Performance (CCG)            |      |           |              |     |               |     |           |             |                  |            |          |           |                |                     |             |
|---|------|-----------|--------------|-----|---------------|-----|-----------|-------------|------------------|------------|----------|-----------|----------------|---------------------|-------------|
| Mov ID  | Turn | Mov Class | Demand Flows |     | Arrival Flows |     | Deg. Satn | Aver. Delay | Level of Service | 95% Back   | Of Queue | Prop. Que | Eff. Stop Rate | Aver. No. of Cycles | Aver. Speed |
|   |      |           | [ Total HV ] | %   | [ Total HV ]  | %   | v/c       | sec         |                  | [ Veh. veh | Dist ]   |           |                |                     | km/h        |
|   |      |           | veh/h        |     | veh/h         |     |           |             |                  | veh        | m        |           |                |                     |             |
| Site: CEN01 [CEN01 Elizabeth St / Eddy Ave]   |      |           |              |     |               |     |           |             |                  |            |          |           |                |                     |             |
| South: Elizabeth St (S)                       |      |           |              |     |               |     |           |             |                  |            |          |           |                |                     |             |
| 1a  | L1   | All MCs   | 401          | 2.4 | 401           | 2.4 | 0.454     | 2.7         | LOS A            | 5.4        | 39.4     | 0.28      | 0.43           | 0.28                | 28.3        |
| 2   | T1   | All MCs   | 958          | 8.5 | 958           | 8.5 | *0.454    | 6.8         | LOS A            | 6.0        | 45.2     | 0.48      | 0.46           | 0.48                | 27.3        |
| Approach                                      |      |           | 1359         | 6.7 | 1359          | 6.7 | 0.454     | 5.6         | LOS A            | 6.0        | 45.2     | 0.42      | 0.45           | 0.42                | 27.5        |
| North: Elizabeth St (N)                       |      |           |              |     |               |     |           |             |                  |            |          |           |                |                     |             |
| 8   | T1   | All MCs   | 500          | 4.4 | 500           | 4.4 | 0.366     | 27.8        | LOS B            | 9.9        | 72.3     | 0.78      | 0.66           | 0.78                | 11.3        |
| 9b  | R3   | All MCs   | 307          | 6.5 | 307           | 6.5 | 0.664     | 54.9        | LOS D            | 8.3        | 61.6     | 0.99      | 0.84           | 1.04                | 9.4         |
| Approach                                      |      |           | 807          | 5.2 | 807           | 5.2 | 0.664     | 38.1        | LOS C            | 9.9        | 72.3     | 0.86      | 0.73           | 0.88                | 10.3        |
| NorthWest: Eddy Ave (NW)                      |      |           |              |     |               |     |           |             |                  |            |          |           |                |                     |             |
| 27b   | L3   | All MCs   | 591          | 3.0 | 591           | 3.0 | *0.723    | 30.3        | LOS C            | 11.3       | 80.8     | 0.97      | 0.86           | 1.01                | 14.5        |
| 29a   | R1   | All MCs   | 126          | 7.5 | 126           | 7.5 | *0.666    | 57.1        | LOS E            | 7.0        | 52.4     | 1.00      | 0.85           | 1.07                | 4.0         |
| Approach                                      |      |           | 717          | 3.8 | 717           | 3.8 | 0.723     | 35.0        | LOS C            | 11.3       | 80.8     | 0.97      | 0.86           | 1.02                | 12.2        |
| All Vehicles                                  |      |           | 2883         | 5.5 | 2883          | 5.5 | 0.723     | 22.0        | LOS B            | 11.3       | 80.8     | 0.68      | 0.63           | 0.70                | 15.1        |
| Site: CEN02 [CEN02 Elizabeth St / Foveaux St] |      |           |              |     |               |     |           |             |                  |            |          |           |                |                     |             |
| South: Elizabeth St (S)                       |      |           |              |     |               |     |           |             |                  |            |          |           |                |                     |             |
| 2   | T1   | All MCs   | 848          | 8.9 | 848           | 8.9 | *0.647    | 31.8        | LOS C            | 19.3       | 145.2    | 0.89      | 0.78           | 0.89                | 11.9        |
| Approach                                      |      |           | 848          | 8.9 | 848           | 8.9 | 0.647     | 31.8        | LOS C            | 19.3       | 145.2    | 0.89      | 0.78           | 0.89                | 11.9        |
| SouthEast: Foveaux St (SE)                    |      |           |              |     |               |     |           |             |                  |            |          |           |                |                     |             |
| 21b   | L3   | All MCs   | 234          | 1.4 | 234           | 1.4 | 0.408     | 33.3        | LOS C            | 9.6        | 68.2     | 0.80      | 0.78           | 0.80                | 17.0        |
| 23a   | R1   | All MCs   | 511          | 2.9 | 511           | 2.9 | 0.406     | 23.1        | LOS B            | 9.1        | 65.3     | 0.70      | 0.72           | 0.70                | 13.6        |
| Approach                                      |      |           | 744          | 2.4 | 744           | 2.4 | 0.408     | 26.3        | LOS B            | 9.6        | 68.2     | 0.73      | 0.74           | 0.73                | 15.1        |
| North: Elizabeth St (N)                       |      |           |              |     |               |     |           |             |                  |            |          |           |                |                     |             |
| 8   | T1   | All MCs   | 626          | 5.0 | 626           | 5.0 | 0.351     | 8.5         | LOS A            | 8.0        | 57.1     | 0.28      | 0.24           | 0.28                | 26.7        |
| Approach                                      |      |           | 626          | 5.0 | 626           | 5.0 | 0.351     | 8.5         | LOS A            | 8.0        | 57.1     | 0.28      | 0.24           | 0.28                | 26.7        |
| All Vehicles                                  |      |           | 2219         | 5.6 | 2219          | 5.6 | 0.647     | 23.4        | LOS B            | 19.3       | 145.2    | 0.66      | 0.61           | 0.66                | 15.8        |

Site Level of Service (LOS) Method: Delay (RTA NSW). Site LOS Method is specified in the Network Data dialog (Override Site Data tab).

Vehicle movement LOS values are based on average delay per movement.

Intersection and Approach LOS values are based on average delay for all vehicle movements.

Delay Model: SIDRA Standard (Control Delay: Geometric Delay is included).

Gap-Acceptance Capacity Formula: SIDRA Standard (Akçelik M3D).

HV (%) values are calculated for All Movement Classes of All Heavy Vehicle Model Designation.

Arrival Flows used in performance calculations are adjusted to include any Initial Queued Demand and Upstream Capacity Constraint effects.

\* Critical Movement (Signal Timing)

---

**SIDRA INTERSECTION 9.1 | Copyright © 2000-2022 Akcelik and Associates Pty Ltd | sidrasolutions.com**

Organisation: AECOM AUSTRALIA PTY LTD | Licence: NETWORK / Enterprise Level 1 | Processed: Friday, 14 July 2023 4:28:14 PM

Project: C:\Users\Yeung\AECOM\ANZ-NAC-Sydney Metro-Sydney Metro C&SW Operational Monitoring - General\400\_Technical\432\_Traffic Analysis\SIDRA Modelling\01 Models (Geometry Only)\Block 1\Rev1\Test\07 SM C&SW\_CEN (Block 1)\_PS\_TEST.sip9

# MOVEMENT SUMMARY

Site: CEN03 [CEN03 Elizabeth St / Cooper St (Site Folder: Block 1 Model - 2023 Weekend Peak)]

Output produced by SIDRA INTERSECTION Version: 9.1.1.200

Network: CEN-N2 [CEN Network 2 (Network Folder: Block 1 Network - 2023 Weekend Peak)]

NA  
 Site Category: (None)  
 Give-Way (Two-Way)

| Vehicle Movement Performance |      |           |                       |     |                       |     |           |             |                  |                   |             |           |                |                     |                  |
|------------------------------|------|-----------|-----------------------|-----|-----------------------|-----|-----------|-------------|------------------|-------------------|-------------|-----------|----------------|---------------------|------------------|
| Mov ID                       | Turn | Mov Class | Demand Flows          |     | Arrival Flows         |     | Deg. Satn | Aver. Delay | Level of Service | 95% Back Of Queue |             | Prop. Que | Eff. Stop Rate | Aver. No. of Cycles | Aver. Speed km/h |
|                              |      |           | [ Total HV ]<br>veh/h | %   | [ Total HV ]<br>veh/h | %   |           |             |                  | [ Veh. veh        | Dist ]<br>m |           |                |                     |                  |
| SouthEast: Cooper St (SE)    |      |           |                       |     |                       |     |           |             |                  |                   |             |           |                |                     |                  |
| 21b                          | L3   | All MCs   | 67                    | 3.1 | 67                    | 3.1 | 0.062     | 5.7         | LOS A            | 0.3               | 1.8         | 0.44      | 0.59           | 0.44                | 33.9             |
| Approach                     |      |           | 67                    | 3.1 | 67                    | 3.1 | 0.062     | 5.7         | LOS A            | 0.3               | 1.8         | 0.44      | 0.59           | 0.44                | 33.9             |
| North: Elizabeth St (N)      |      |           |                       |     |                       |     |           |             |                  |                   |             |           |                |                     |                  |
| 7a                           | L1   | All MCs   | 47                    | 0.0 | 47                    | 0.0 | 0.186     | 3.2         | LOS A            | 0.3               | 2.5         | 0.08      | 0.10           | 0.08                | 37.7             |
| 8                            | T1   | All MCs   | 967                   | 4.9 | 967                   | 4.9 | 0.186     | 0.0         | LOS A            | 0.3               | 2.5         | 0.02      | 0.03           | 0.02                | 39.5             |
| Approach                     |      |           | 1015                  | 4.7 | 1015                  | 4.7 | 0.186     | 0.2         | NA               | 0.3               | 2.5         | 0.03      | 0.03           | 0.03                | 39.3             |
| All Vehicles                 |      |           | 1082                  | 4.6 | 1082                  | 4.6 | 0.186     | 0.5         | NA               | 0.3               | 2.5         | 0.05      | 0.07           | 0.05                | 38.3             |

Site Level of Service (LOS) Method: Delay (RTA NSW). Site LOS Method is specified in the Network Data dialog (Override Site Data tab).

Vehicle movement LOS values are based on average delay per movement.

Minor Road Approach LOS values are based on average delay for all vehicle movements.

NA (TWSC): Level of Service is not defined for major road approaches or the intersection as a whole for Two-Way Sign Control (HCM LOS rule).

Two-Way Sign Control Capacity Model: SIDRA Standard.

Delay Model: SIDRA Standard (Control Delay: Geometric Delay is included).

Queue Model: SIDRA queue estimation methods are used for Back of Queue and Queue at Start of Gap.

Gap-Acceptance Capacity Formula: SIDRA Standard (Akçelik M3D).

HV (%) values are calculated for All Movement Classes of All Heavy Vehicle Model Designation.

Arrival Flows used in performance calculations are adjusted to include any Initial Queued Demand and Upstream Capacity Constraint effects.



---

**SIDRA INTERSECTION 9.1 | Copyright © 2000-2022 Akcelik and Associates Pty Ltd | sidrasolutions.com**

Organisation: AECOM AUSTRALIA PTY LTD | Licence: NETWORK / Enterprise Level 1 | Processed: Friday, 14 July 2023 3:32:59 PM

Project: C:\Users\Yeung\AECOM\ANZ-NAC-Sydney Metro-Sydney Metro C&SW Operational Monitoring - General\400\_Technical\432\_Traffic Analysis\SIDRA Modelling\01 Models (Geometry Only)\Block 1\Rev1\Test\07 SM C&SW\_CEN (Block 1)\_PS\_TEST.sip9

# MOVEMENT SUMMARY

Site: CEN05 [CEN05 Elizabeth St / Randle St (Site Folder: Block 1 Model - 2023 Weekend Peak)]

Output produced by SIDRA INTERSECTION Version: 9.1.1.200

Network: CEN-N2 [CEN Network 2 (Network Folder: Block 1 Network - 2023 Weekend Peak)]

TCS 2916

Site Category: (None)

Signals - EQUISAT (Fixed-Time/SCATS) Isolated Cycle Time = 110 seconds (Site User-Given Phase Times)

| Vehicle Movement Performance |      |           |                       |     |                       |     |           |             |                  |                   |               |           |                |                     |             |
|------------------------------|------|-----------|-----------------------|-----|-----------------------|-----|-----------|-------------|------------------|-------------------|---------------|-----------|----------------|---------------------|-------------|
| Mov ID                       | Turn | Mov Class | Demand Flows          |     | Arrival Flows         |     | Deg. Satn | Aver. Delay | Level of Service | 95% Back Of Queue |               | Prop. Que | Eff. Stop Rate | Aver. No. of Cycles | Aver. Speed |
|                              |      |           | [ Total HV ]<br>veh/h | %   | [ Total HV ]<br>veh/h | %   |           |             |                  | [ Veh. veh        | [ Dist ]<br>m |           |                |                     |             |
| North: Elizabeth St (N)      |      |           |                       |     |                       |     |           |             |                  |                   |               |           |                |                     |             |
| 8                            | T1   | All MCs   | 920                   | 4.9 | 920                   | 4.9 | 0.306     | 2.8         | LOS A            | 6.1               | 44.6          | 0.27      | 0.24           | 0.27                | 33.1        |
| Approach                     |      |           | 920                   | 4.9 | 920                   | 4.9 | 0.306     | 2.8         | LOS A            | 6.1               | 44.6          | 0.27      | 0.24           | 0.27                | 33.1        |
| SouthWest: Randle St (SW)    |      |           |                       |     |                       |     |           |             |                  |                   |               |           |                |                     |             |
| 30a                          | L1   | All MCs   | 935                   | 8.8 | 935                   | 8.8 | * 0.604   | 27.6        | LOS B            | 18.0              | 135.1         | 0.70      | 0.75           | 0.70                | 21.3        |
| 32b                          | R3   | All MCs   | 95                    | 2.2 | 95                    | 2.2 | * 0.604   | 4.7         | LOS A            | 14.4              | 106.8         | 0.71      | 0.78           | 0.71                | 14.4        |
| Approach                     |      |           | 1029                  | 8.2 | 1029                  | 8.2 | 0.604     | 25.5        | LOS B            | 18.0              | 135.1         | 0.70      | 0.75           | 0.70                | 20.9        |
| All Vehicles                 |      |           | 1949                  | 6.6 | 1949                  | 6.6 | 0.604     | 14.8        | LOS B            | 18.0              | 135.1         | 0.50      | 0.51           | 0.50                | 24.0        |

Site Level of Service (LOS) Method: Delay (RTA NSW). Site LOS Method is specified in the Network Data dialog (Override Site Data tab).

Vehicle movement LOS values are based on average delay per movement.

Intersection and Approach LOS values are based on average delay for all vehicle movements.

Delay Model: SIDRA Standard (Control Delay: Geometric Delay is included).

Queue Model: SIDRA queue estimation methods are used for Back of Queue and Queue at Start of Green.

Gap-Acceptance Capacity Formula: SIDRA Standard (Akçelik M3D).

HV (%) values are calculated for All Movement Classes of All Heavy Vehicle Model Designation.

Arrival Flows used in performance calculations are adjusted to include any Initial Queued Demand and Upstream Capacity Constraint effects.

\* Critical Movement (Signal Timing)

| Pedestrian Movement Performance |          |           |             |                  |                       |        |           |                |             |              |             |
|---------------------------------|----------|-----------|-------------|------------------|-----------------------|--------|-----------|----------------|-------------|--------------|-------------|
| Mov ID                          | Crossing | Dem. Flow | Aver. Delay | Level of Service | AVERAGE BACK OF QUEUE |        | Prop. Que | Eff. Stop Rate | Travel Time | Travel Dist. | Aver. Speed |
|                                 |          | ped/h     | sec         |                  | [ Ped                 | Dist ] |           |                | sec         | m            | m/sec       |
|                                 |          |           |             |                  | ped                   | m      |           |                |             |              |             |
| South: Elizabeth St (S)         |          |           |             |                  |                       |        |           |                |             |              |             |
| P1                              | Full     | 124       | 48.5        | LOS E            | 0.4                   | 0.4    | 0.94      | 0.94           | 215.1       | 200.0        | 0.93        |
| SouthWest: Randle St (SW)       |          |           |             |                  |                       |        |           |                |             |              |             |
| P8                              | Full     | 64        | 44.7        | LOS E            | 0.2                   | 0.2    | 0.90      | 0.90           | 211.3       | 200.0        | 0.95        |
| All Pedestrians                 |          | 188       | 47.2        | LOS E            | 0.4                   | 0.4    | 0.93      | 0.93           | 213.8       | 200.0        | 0.94        |

Level of Service (LOS) Method: SIDRA Pedestrian LOS Method (Based on Average Delay)

Pedestrian movement LOS values are based on average delay per pedestrian movement.

Intersection LOS value for Pedestrians is based on average delay for all pedestrian movements.

---

**SIDRA INTERSECTION 9.1 | Copyright © 2000-2022 Akcelik and Associates Pty Ltd | sidrasolutions.com**

Organisation: AECOM AUSTRALIA PTY LTD | Licence: NETWORK / Enterprise Level 1 | Processed: Friday, 14 July 2023 3:32:59 PM

Project: C:\Users\YeungM\AECOM\ANZ-NAC-Sydney Metro-Sydney Metro C&SW Operational Monitoring - General\400\_Technical\432\_Traffic Analysis\SIDRA Modelling\01 Models (Geometry Only)\Block 1\Rev1\Test\07 SM C&SW\_CEN (Block 1)\_PS\_TEST.sip9

# MOVEMENT SUMMARY

Site: WLO01 [WLO01 Botany Rd / Raglan St / Henderson Rd  
(Site Folder: Block 1 Model - 2023 AM Peak)]

Output produced by SIDRA INTERSECTION Version: 9.1.1.200

Network: WLO-N1 [WLO  
Network 1 (Network Folder:  
Block 1 Network - 2023 AM  
Peak)]

TCS 47

Site Category: (None)

Signals - EQUISAT (Fixed-Time/SCATS) Coordinated Cycle Time = 120 seconds (Network Site User-Given Phase Times)

| Vehicle Movement Performance |      |           |              |      |               |      |           |             |                  |                   |            |           |                |                     |             |
|------------------------------|------|-----------|--------------|------|---------------|------|-----------|-------------|------------------|-------------------|------------|-----------|----------------|---------------------|-------------|
| Mov ID                       | Turn | Mov Class | Demand Flows |      | Arrival Flows |      | Deg. Satn | Aver. Delay | Level of Service | 95% Back Of Queue |            | Prop. Que | Eff. Stop Rate | Aver. No. of Cycles | Aver. Speed |
|                              |      |           | [ Total HV ] | %    | [ Total HV ]  | %    |           |             |                  | [ Veh. veh        | [ Dist ] m |           |                |                     |             |
| South: Botany Rd (S)         |      |           |              |      |               |      |           |             |                  |                   |            |           |                |                     |             |
| 1                            | L2   | All MCs   | 802          | 5.4  | 802           | 5.4  | *0.775    | 33.0        | LOS C            | 19.9              | 145.7      | 0.86      | 0.84           | 0.88                | 17.0        |
| Approach                     |      |           | 802          | 5.4  | 802           | 5.4  | 0.775     | 33.0        | LOS C            | 19.9              | 145.7      | 0.86      | 0.84           | 0.88                | 17.0        |
| East: Raglan St (E)          |      |           |              |      |               |      |           |             |                  |                   |            |           |                |                     |             |
| 4                            | L2   | All MCs   | 33           | 16.1 | 33            | 16.1 | *0.776    | 89.3        | LOS F            | 8.0               | 60.1       | 1.00      | 0.93           | 1.20                | 4.5         |
| 5                            | T1   | All MCs   | 229          | 5.5  | 229           | 5.5  | 0.776     | 83.1        | LOS F            | 8.0               | 60.1       | 1.00      | 0.93           | 1.20                | 4.6         |
| Approach                     |      |           | 262          | 6.8  | 262           | 6.8  | 0.776     | 83.8        | LOS F            | 8.0               | 60.1       | 1.00      | 0.93           | 1.20                | 4.5         |
| North: Botany Rd (N)         |      |           |              |      |               |      |           |             |                  |                   |            |           |                |                     |             |
| 7                            | L2   | All MCs   | 73           | 18.8 | 73            | 18.8 | 0.370     | 11.1        | LOS A            | 9.5               | 72.8       | 0.37      | 0.39           | 0.37                | 35.2        |
| 8                            | T1   | All MCs   | 902          | 9.3  | 902           | 9.3  | 0.370     | 5.4         | LOS A            | 9.8               | 74.0       | 0.37      | 0.36           | 0.37                | 35.8        |
| 9                            | R2   | All MCs   | 601          | 4.6  | 601           | 4.6  | *0.789    | 56.0        | LOS D            | 18.4              | 134.1      | 1.00      | 0.90           | 1.10                | 10.1        |
| Approach                     |      |           | 1576         | 7.9  | 1576          | 7.9  | 0.789     | 25.0        | LOS B            | 18.4              | 134.1      | 0.61      | 0.57           | 0.65                | 18.3        |
| West: Henderson Rd (W)       |      |           |              |      |               |      |           |             |                  |                   |            |           |                |                     |             |
| 11                           | T1   | All MCs   | 234          | 2.3  | 234           | 2.3  | 0.702     | 18.4        | LOS B            | 5.8               | 41.7       | 0.57      | 0.48           | 0.59                | 11.7        |
| 12                           | R2   | All MCs   | 35           | 9.1  | 35            | 9.1  | 0.702     | 66.2        | LOS E            | 4.0               | 29.4       | 0.97      | 0.77           | 1.02                | 4.6         |
| Approach                     |      |           | 268          | 3.1  | 268           | 3.1  | 0.702     | 24.5        | LOS B            | 5.8               | 41.7       | 0.63      | 0.51           | 0.65                | 9.8         |
| All Vehicles                 |      |           | 2908         | 6.7  | 2908          | 6.7  | 0.789     | 32.5        | LOS C            | 19.9              | 145.7      | 0.72      | 0.67           | 0.76                | 15.5        |

Site Level of Service (LOS) Method: Delay (RTA NSW). Site LOS Method is specified in the Network Data dialog (Override Site Data tab).

Vehicle movement LOS values are based on average delay per movement.

Intersection and Approach LOS values are based on average delay for all vehicle movements.

Delay Model: SIDRA Standard (Control Delay: Geometric Delay is included).

Queue Model: SIDRA queue estimation methods are used for Back of Queue and Queue at Start of Green.

Gap-Acceptance Capacity Formula: SIDRA Standard (Akçelik M3D).

HV (%) values are calculated for All Movement Classes of All Heavy Vehicle Model Designation.

Arrival Flows used in performance calculations are adjusted to include any Initial Queued Demand and Upstream Capacity Constraint effects.

\* Critical Movement (Signal Timing)

| Pedestrian Movement Performance |          |           |             |                  |                       |        |           |                |             |              |             |
|---------------------------------|----------|-----------|-------------|------------------|-----------------------|--------|-----------|----------------|-------------|--------------|-------------|
| Mov ID                          | Crossing | Dem. Flow | Aver. Delay | Level of Service | AVERAGE BACK OF QUEUE |        | Prop. Que | Eff. Stop Rate | Travel Time | Travel Dist. | Aver. Speed |
|                                 |          | ped/h     | sec         |                  | [ Ped                 | Dist ] |           |                | sec         | m            | m/sec       |
|                                 |          |           |             |                  | ped                   | m      |           |                |             |              |             |
| South: Botany Rd (S)            |          |           |             |                  |                       |        |           |                |             |              |             |
| P1                              | Full     | 47        | 49.6        | LOS E            | 0.1                   | 0.1    | 0.91      | 0.91           | 66.3        | 20.0         | 0.30        |
| East: Raglan St (E)             |          |           |             |                  |                       |        |           |                |             |              |             |
| P2                              | Full     | 48        | 49.6        | LOS E            | 0.2                   | 0.2    | 0.91      | 0.91           | 66.3        | 20.0         | 0.30        |
| North: Botany Rd (N)            |          |           |             |                  |                       |        |           |                |             |              |             |
| P3                              | Full     | 99        | 48.8        | LOS E            | 0.3                   | 0.3    | 0.90      | 0.90           | 65.5        | 20.0         | 0.31        |
| West: Henderson Rd (W)          |          |           |             |                  |                       |        |           |                |             |              |             |
| P4                              | Full     | 57        | 47.8        | LOS E            | 0.2                   | 0.2    | 0.89      | 0.89           | 64.5        | 20.0         | 0.31        |
| All Pedestrians                 |          | 252       | 48.9        | LOS E            | 0.3                   | 0.3    | 0.90      | 0.90           | 65.6        | 20.0         | 0.31        |

Level of Service (LOS) Method: SIDRA Pedestrian LOS Method (Based on Average Delay)

Pedestrian movement LOS values are based on average delay per pedestrian movement.

Intersection LOS value for Pedestrians is based on average delay for all pedestrian movements.

**SIDRA INTERSECTION 9.1 | Copyright © 2000-2022 Akcelik and Associates Pty Ltd | sidrasolutions.com**

Organisation: AECOM AUSTRALIA PTY LTD | Licence: NETWORK / Enterprise Level 1 | Processed: Thursday, 13 July 2023 12:12:07 PM

Project: C:\Users\YeungMA\AECOM\ANZ-NAC-Sydney Metro-Sydney Metro C&SW Operational Monitoring - General\400\_Technical\432\_Traffic

Analysis\SIDRA Modelling\01 Models (Geometry Only)\Block 1\Rev1\_Review\08 SM C&SW\_WLO (Block 1)\_PS.sip9

# MOVEMENT SUMMARY

Site: WLO02 [WLO02 Raglan St / Cope St (Site Folder: Block 1 Model - 2023 AM Peak)]

Output produced by SIDRA INTERSECTION Version: 9.1.1.200

Network: WLO-N1 [WLO Network 1 (Network Folder: Block 1 Network - 2023 AM Peak)]

NA  
Site Category: (None)  
Roundabout

| Vehicle Movement Performance |      |           |                       |     |                       |     |           |             |                  |                   |               |           |                |                     |                  |
|------------------------------|------|-----------|-----------------------|-----|-----------------------|-----|-----------|-------------|------------------|-------------------|---------------|-----------|----------------|---------------------|------------------|
| Mov ID                       | Turn | Mov Class | Demand Flows          |     | Arrival Flows         |     | Deg. Satn | Aver. Delay | Level of Service | 95% Back Of Queue |               | Prop. Que | Eff. Stop Rate | Aver. No. of Cycles | Aver. Speed km/h |
|                              |      |           | [ Total HV ]<br>veh/h | %   | [ Total HV ]<br>veh/h | %   |           |             |                  | [ Veh. veh        | [ Dist ]<br>m |           |                |                     |                  |
| East: Raglan St (E)          |      |           |                       |     |                       |     |           |             |                  |                   |               |           |                |                     |                  |
| 5                            | T1   | All MCs   | 202                   | 7.8 | 202                   | 7.8 | 0.198     | 4.2         | LOSA             | 1.3               | 9.7           | 0.28      | 0.45           | 0.28                | 40.2             |
| 6                            | R2   | All MCs   | 35                    | 3.0 | 35                    | 3.0 | 0.198     | 7.3         | LOSA             | 1.3               | 9.7           | 0.28      | 0.45           | 0.28                | 42.0             |
| 6u                           | U    | All MCs   | 3                     | 0.0 | 3                     | 0.0 | 0.198     | 8.7         | LOSA             | 1.3               | 9.7           | 0.28      | 0.45           | 0.28                | 42.5             |
| Approach                     |      |           | 240                   | 7.0 | 240                   | 7.0 | 0.198     | 4.7         | LOSA             | 1.3               | 9.7           | 0.28      | 0.45           | 0.28                | 40.6             |
| North: Cope St (N)           |      |           |                       |     |                       |     |           |             |                  |                   |               |           |                |                     |                  |
| 7                            | L2   | All MCs   | 17                    | 6.3 | 17                    | 6.3 | 0.082     | 5.3         | LOSA             | 0.5               | 3.6           | 0.43      | 0.59           | 0.43                | 40.4             |
| 9                            | R2   | All MCs   | 64                    | 3.3 | 64                    | 3.3 | 0.082     | 8.3         | LOSA             | 0.5               | 3.6           | 0.43      | 0.59           | 0.43                | 35.8             |
| 9u                           | U    | All MCs   | 1                     | 0.0 | 1                     | 0.0 | 0.082     | 9.6         | LOSA             | 0.5               | 3.6           | 0.43      | 0.59           | 0.43                | 39.5             |
| Approach                     |      |           | 82                    | 3.8 | 82                    | 3.8 | 0.082     | 7.7         | LOSA             | 0.5               | 3.6           | 0.43      | 0.59           | 0.43                | 37.3             |
| West: Raglan St (W)          |      |           |                       |     |                       |     |           |             |                  |                   |               |           |                |                     |                  |
| 10                           | L2   | All MCs   | 83                    | 0.0 | 83                    | 0.0 | 0.219     | 3.9         | LOSA             | 1.2               | 9.1           | 0.16      | 0.44           | 0.16                | 39.7             |
| 11                           | T1   | All MCs   | 205                   | 7.2 | 205                   | 7.2 | 0.219     | 3.8         | LOSA             | 1.2               | 9.1           | 0.16      | 0.44           | 0.16                | 41.2             |
| 12u                          | U    | All MCs   | 5                     | 0.0 | 5                     | 0.0 | 0.219     | 8.4         | LOSA             | 1.2               | 9.1           | 0.16      | 0.44           | 0.16                | 28.7             |
| Approach                     |      |           | 294                   | 5.0 | 294                   | 5.0 | 0.219     | 3.9         | LOSA             | 1.2               | 9.1           | 0.16      | 0.44           | 0.16                | 40.8             |
| All Vehicles                 |      |           | 616                   | 5.6 | 616                   | 5.6 | 0.219     | 4.7         | LOSA             | 1.3               | 9.7           | 0.25      | 0.46           | 0.25                | 40.2             |

Site Level of Service (LOS) Method: Delay (RTA NSW). Site LOS Method is specified in the Network Data dialog (Override Site Data tab).

Vehicle movement LOS values are based on average delay per movement.

Intersection and Approach LOS values are based on average delay for all vehicle movements.

Roundabout Capacity Model: SIDRA Standard.

Delay Model: SIDRA Standard (Control Delay: Geometric Delay is included).

Queue Model: SIDRA queue estimation methods are used for Back of Queue and Queue at Start of Gap.

Gap-Acceptance Capacity Formula: SIDRA Standard (Akçelik M3D).

HV (%) values are calculated for All Movement Classes of All Heavy Vehicle Model Designation.

Arrival Flows used in performance calculations are adjusted to include any Initial Queued Demand and Upstream Capacity Constraint effects.

---

**SIDRA INTERSECTION 9.1 | Copyright © 2000-2022 Akcelik and Associates Pty Ltd | sidrasolutions.com**

Organisation: AECOM AUSTRALIA PTY LTD | Licence: NETWORK / Enterprise Level 1 | Processed: Thursday, 13 July 2023 12:12:07 PM

Project: C:\Users\Yeung\AECOM\ANZ-NAC-Sydney Metro-Sydney Metro C&SW Operational Monitoring - General\400\_Technical\432\_Traffic Analysis\SIDRA Modelling\01 Models (Geometry Only)\Block 1\Rev1\\_Review\08 SM C&SW\_WLO (Block 1)\_PS.sip9

# MOVEMENT SUMMARY

Site: WLO03 [WLO03 Botany Rd / Wellington St / Buckland St  
(Site Folder: Block 1 Model - 2023 AM Peak)]

Output produced by SIDRA INTERSECTION Version: 9.1.1.200

Network: WLO-N1 [WLO  
Network 1 (Network Folder:  
Block 1 Network - 2023 AM  
Peak)]

TCS 137

Site Category: (None)

Signals - EQUISAT (Fixed-Time/SCATS) Coordinated Cycle Time = 120 seconds (Network Site User-Given Phase Times)

| Vehicle Movement Performance |      |           |                       |      |                       |      |           |             |                  |                   |               |           |                |                     |             |
|------------------------------|------|-----------|-----------------------|------|-----------------------|------|-----------|-------------|------------------|-------------------|---------------|-----------|----------------|---------------------|-------------|
| Mov ID                       | Turn | Mov Class | Demand Flows          |      | Arrival Flows         |      | Deg. Satn | Aver. Delay | Level of Service | 95% Back Of Queue |               | Prop. Que | Eff. Stop Rate | Aver. No. of Cycles | Aver. Speed |
|                              |      |           | [ Total HV ]<br>veh/h | %    | [ Total HV ]<br>veh/h | %    |           |             |                  | [ Veh. veh        | [ Dist ]<br>m |           |                |                     |             |
| South: Botany Rd (S)         |      |           |                       |      |                       |      |           |             |                  |                   |               |           |                |                     |             |
| 2                            | T1   | All MCs   | 780                   | 5.3  | 780                   | 5.3  | *0.484    | 8.9         | LOS A            | 16.4              | 119.6         | 0.51      | 0.48           | 0.51                | 34.6        |
| 3                            | R2   | All MCs   | 104                   | 7.1  | 104                   | 7.1  | 0.484     | 22.3        | LOS B            | 8.1               | 59.8          | 0.58      | 0.61           | 0.58                | 29.9        |
| Approach                     |      |           | 884                   | 5.5  | 884                   | 5.5  | 0.484     | 10.5        | LOS A            | 16.4              | 119.6         | 0.52      | 0.49           | 0.52                | 34.0        |
| East: Wellington St (E)      |      |           |                       |      |                       |      |           |             |                  |                   |               |           |                |                     |             |
| 4                            | L2   | All MCs   | 46                    | 11.4 | 46                    | 11.4 | 0.168     | 51.1        | LOS D            | 2.4               | 18.1          | 0.89      | 0.73           | 0.89                | 16.7        |
| 6                            | R2   | All MCs   | 21                    | 5.0  | 21                    | 5.0  | 0.101     | 52.7        | LOS D            | 1.1               | 7.9           | 0.89      | 0.71           | 0.89                | 4.5         |
| Approach                     |      |           | 67                    | 9.4  | 67                    | 9.4  | 0.168     | 51.6        | LOS D            | 2.4               | 18.1          | 0.89      | 0.73           | 0.89                | 13.7        |
| North: Botany Rd (N)         |      |           |                       |      |                       |      |           |             |                  |                   |               |           |                |                     |             |
| 7                            | L2   | All MCs   | 21                    | 10.0 | 21                    | 10.0 | 0.390     | 13.5        | LOS A            | 10.2              | 77.1          | 0.40      | 0.37           | 0.40                | 35.5        |
| 8                            | T1   | All MCs   | 947                   | 9.6  | 947                   | 9.6  | 0.390     | 6.6         | LOS A            | 10.4              | 78.6          | 0.40      | 0.36           | 0.40                | 42.4        |
| Approach                     |      |           | 968                   | 9.6  | 968                   | 9.6  | 0.390     | 6.8         | LOS A            | 10.4              | 78.6          | 0.40      | 0.36           | 0.40                | 42.3        |
| West: Buckland St (W)        |      |           |                       |      |                       |      |           |             |                  |                   |               |           |                |                     |             |
| 10                           | L2   | All MCs   | 5                     | 0.0  | 5                     | 0.0  | 0.332     | 50.8        | LOS D            | 6.3               | 45.3          | 0.90      | 0.73           | 0.90                | 5.9         |
| 11                           | T1   | All MCs   | 120                   | 2.6  | 120                   | 2.6  | *0.332    | 45.5        | LOS D            | 6.3               | 45.3          | 0.90      | 0.73           | 0.90                | 5.9         |
| 12                           | R2   | All MCs   | 16                    | 6.7  | 16                    | 6.7  | 0.064     | 50.3        | LOS D            | 0.8               | 5.8           | 0.87      | 0.69           | 0.87                | 16.9        |
| Approach                     |      |           | 141                   | 3.0  | 141                   | 3.0  | 0.332     | 46.3        | LOS D            | 6.3               | 45.3          | 0.90      | 0.72           | 0.90                | 7.7         |
| All Vehicles                 |      |           | 2061                  | 7.4  | 2061                  | 7.4  | 0.484     | 12.5        | LOS A            | 16.4              | 119.6         | 0.50      | 0.46           | 0.50                | 34.6        |

Site Level of Service (LOS) Method: Delay (RTA NSW). Site LOS Method is specified in the Network Data dialog (Override Site Data tab).

Vehicle movement LOS values are based on average delay per movement.

Intersection and Approach LOS values are based on average delay for all vehicle movements.

Delay Model: SIDRA Standard (Control Delay: Geometric Delay is included).

Queue Model: SIDRA queue estimation methods are used for Back of Queue and Queue at Start of Green.

Gap-Acceptance Capacity Formula: SIDRA Standard (Akçelik M3D).

HV (%) values are calculated for All Movement Classes of All Heavy Vehicle Model Designation.

Arrival Flows used in performance calculations are adjusted to include any Initial Queued Demand and Upstream Capacity Constraint effects.

\* Critical Movement (Signal Timing)



| Pedestrian Movement Performance |          |           |             |                  |                       |        |           |                |             |              |             |
|---------------------------------|----------|-----------|-------------|------------------|-----------------------|--------|-----------|----------------|-------------|--------------|-------------|
| Mov ID                          | Crossing | Dem. Flow | Aver. Delay | Level of Service | AVERAGE BACK OF QUEUE |        | Prop. Que | Eff. Stop Rate | Travel Time | Travel Dist. | Aver. Speed |
|                                 |          | ped/h     | sec         |                  | [ Ped                 | Dist ] |           |                | sec         | m            | m/sec       |
|                                 |          |           |             |                  | ped                   | m      |           |                |             |              |             |
| South: Botany Rd (S)            |          |           |             |                  |                       |        |           |                |             |              |             |
| P1                              | Full     | 61        | 48.7        | LOS E            | 0.2                   | 0.2    | 0.90      | 0.90           | 65.4        | 20.0         | 0.31        |
| East: Wellington St (E)         |          |           |             |                  |                       |        |           |                |             |              |             |
| P2                              | Full     | 120       | 48.8        | LOS E            | 0.4                   | 0.4    | 0.90      | 0.90           | 65.5        | 20.0         | 0.31        |
| North: Botany Rd (N)            |          |           |             |                  |                       |        |           |                |             |              |             |
| P3                              | Full     | 64        | 48.7        | LOS E            | 0.2                   | 0.2    | 0.90      | 0.90           | 65.4        | 20.0         | 0.31        |
| West: Buckland St (W)           |          |           |             |                  |                       |        |           |                |             |              |             |
| P4                              | Full     | 56        | 48.7        | LOS E            | 0.2                   | 0.2    | 0.90      | 0.90           | 65.4        | 20.0         | 0.31        |
| All Pedestrians                 |          | 301       | 48.8        | LOS E            | 0.4                   | 0.4    | 0.90      | 0.90           | 65.4        | 20.0         | 0.31        |

Level of Service (LOS) Method: SIDRA Pedestrian LOS Method (Based on Average Delay)

Pedestrian movement LOS values are based on average delay per pedestrian movement.

Intersection LOS value for Pedestrians is based on average delay for all pedestrian movements.

**SIDRA INTERSECTION 9.1 | Copyright © 2000-2022 Akcelik and Associates Pty Ltd | sidrasolutions.com**

Organisation: AECOM AUSTRALIA PTY LTD | Licence: NETWORK / Enterprise Level 1 | Processed: Thursday, 13 July 2023 12:12:07 PM  
 Project: C:\Users\YeungMA\AECOM\ANZ-NAC-Sydney Metro-Sydney Metro C&SW Operational Monitoring - General\400\_Technical\432\_Traffic Analysis\SIDRA Modelling\01 Models (Geometry Only)\Block 1\Rev1\_Review\08 SM C&SW\_WLO (Block 1)\_PS.sip9

# MOVEMENT SUMMARY

Site: WLO04 [WLO04 Cope St / Wellington St (Site Folder: Block 1 Model - 2023 AM Peak)]

Output produced by SIDRA INTERSECTION Version: 9.1.1.200

Network: WLO-N1 [WLO Network 1 (Network Folder: Block 1 Network - 2023 AM Peak)]

NA  
Site Category: (None)  
Roundabout

| Vehicle Movement Performance |      |           |                       |      |                       |      |           |             |                  |                   |               |           |                |                     |                  |
|------------------------------|------|-----------|-----------------------|------|-----------------------|------|-----------|-------------|------------------|-------------------|---------------|-----------|----------------|---------------------|------------------|
| Mov ID                       | Turn | Mov Class | Demand Flows          |      | Arrival Flows         |      | Deg. Satn | Aver. Delay | Level of Service | 95% Back Of Queue |               | Prop. Que | Eff. Stop Rate | Aver. No. of Cycles | Aver. Speed km/h |
|                              |      |           | [ Total HV ]<br>veh/h | %    | [ Total HV ]<br>veh/h | %    |           |             |                  | [ Veh. veh        | [ Dist ]<br>m |           |                |                     |                  |
| South: Cope St (S)           |      |           |                       |      |                       |      |           |             |                  |                   |               |           |                |                     |                  |
| 1                            | L2   | All MCs   | 18                    | 0.0  | 18                    | 0.0  | 0.026     | 4.3         | LOS A            | 0.1               | 1.0           | 0.21      | 0.53           | 0.21                | 33.3             |
| 3                            | R2   | All MCs   | 12                    | 0.0  | 12                    | 0.0  | 0.026     | 7.0         | LOS A            | 0.1               | 1.0           | 0.21      | 0.53           | 0.21                | 35.7             |
| 3u                           | U    | All MCs   | 1                     | 0.0  | 1                     | 0.0  | 0.026     | 8.4         | LOS A            | 0.1               | 1.0           | 0.21      | 0.53           | 0.21                | 36.6             |
| Approach                     |      |           | 31                    | 0.0  | 31                    | 0.0  | 0.026     | 5.5         | LOS A            | 0.1               | 1.0           | 0.21      | 0.53           | 0.21                | 34.6             |
| East: Wellington St (E)      |      |           |                       |      |                       |      |           |             |                  |                   |               |           |                |                     |                  |
| 4                            | L2   | All MCs   | 15                    | 0.0  | 15                    | 0.0  | 0.053     | 4.2         | LOS A            | 0.3               | 2.4           | 0.16      | 0.45           | 0.16                | 37.8             |
| 5                            | T1   | All MCs   | 45                    | 11.6 | 45                    | 11.6 | 0.053     | 4.1         | LOS A            | 0.3               | 2.4           | 0.16      | 0.45           | 0.16                | 33.8             |
| 6u                           | U    | All MCs   | 3                     | 0.0  | 3                     | 0.0  | 0.053     | 8.2         | LOS A            | 0.3               | 2.4           | 0.16      | 0.45           | 0.16                | 36.3             |
| Approach                     |      |           | 63                    | 8.3  | 63                    | 8.3  | 0.053     | 4.3         | LOS A            | 0.3               | 2.4           | 0.16      | 0.45           | 0.16                | 35.3             |
| West: Wellington St (W)      |      |           |                       |      |                       |      |           |             |                  |                   |               |           |                |                     |                  |
| 11                           | T1   | All MCs   | 201                   | 6.8  | 201                   | 6.8  | 0.166     | 3.5         | LOS A            | 0.9               | 6.5           | 0.08      | 0.47           | 0.08                | 35.1             |
| 12                           | R2   | All MCs   | 29                    | 0.0  | 29                    | 0.0  | 0.166     | 6.5         | LOS A            | 0.9               | 6.5           | 0.08      | 0.47           | 0.08                | 35.6             |
| 12u                          | U    | All MCs   | 7                     | 0.0  | 7                     | 0.0  | 0.166     | 7.9         | LOS A            | 0.9               | 6.5           | 0.08      | 0.47           | 0.08                | 28.5             |
| Approach                     |      |           | 238                   | 5.8  | 238                   | 5.8  | 0.166     | 4.0         | LOS A            | 0.9               | 6.5           | 0.08      | 0.47           | 0.08                | 35.0             |
| All Vehicles                 |      |           | 332                   | 5.7  | 332                   | 5.7  | 0.166     | 4.2         | LOS A            | 0.9               | 6.5           | 0.11      | 0.47           | 0.11                | 35.0             |

Site Level of Service (LOS) Method: Delay (RTA NSW). Site LOS Method is specified in the Network Data dialog (Override Site Data tab).

Vehicle movement LOS values are based on average delay per movement.

Intersection and Approach LOS values are based on average delay for all vehicle movements.

Roundabout Capacity Model: SIDRA Standard.

Delay Model: SIDRA Standard (Control Delay: Geometric Delay is included).

Queue Model: SIDRA queue estimation methods are used for Back of Queue and Queue at Start of Gap.

Gap-Acceptance Capacity Formula: SIDRA Standard (Akçelik M3D).

HV (%) values are calculated for All Movement Classes of All Heavy Vehicle Model Designation.

Arrival Flows used in performance calculations are adjusted to include any Initial Queued Demand and Upstream Capacity Constraint effects.

---

**SIDRA INTERSECTION 9.1 | Copyright © 2000-2022 Akcelik and Associates Pty Ltd | sidrasolutions.com**

Organisation: AECOM AUSTRALIA PTY LTD | Licence: NETWORK / Enterprise Level 1 | Processed: Thursday, 13 July 2023 12:12:07 PM

Project: C:\Users\Yeung\AECOMANZ-NAC-Sydney Metro-Sydney Metro C&SW Operational Monitoring - General\400\_Technical\432\_Traffic Analysis\SIDRA Modelling\01 Models (Geometry Only)\Block 1\Rev1\\_Review\08 SM C&SW\_WLO (Block 1)\_PS.sip9

# MOVEMENT SUMMARY

Site: WLO05 [WLO05 Wyndham St / Henderson Rd (Site Folder: Block 1 Model - 2023 AM Peak)]

Output produced by SIDRA INTERSECTION Version: 9.1.1.200

Network: WLO-N1 [WLO Network 1 (Network Folder: Block 1 Network - 2023 AM Peak)]

TCS 55

Site Category: (None)

Signals - EQUISAT (Fixed-Time/SCATS) Coordinated Cycle Time = 120 seconds (Network Site User-Given Phase Times)

| Vehicle Movement Performance |      |           |              |      |               |      |           |             |                  |                   |          |           |                |                     |             |
|------------------------------|------|-----------|--------------|------|---------------|------|-----------|-------------|------------------|-------------------|----------|-----------|----------------|---------------------|-------------|
| Mov ID                       | Turn | Mov Class | Demand Flows |      | Arrival Flows |      | Deg. Satn | Aver. Delay | Level of Service | 95% Back Of Queue |          | Prop. Que | Eff. Stop Rate | Aver. No. of Cycles | Aver. Speed |
|                              |      |           | [ Total HV ] | %    | [ Total HV ]  | %    |           |             |                  | [ Veh. veh        | Dist ] m |           |                |                     |             |
| South: Wyndham St (S)        |      |           |              |      |               |      |           |             |                  |                   |          |           |                |                     |             |
| 1                            | L2   | All MCs   | 23           | 4.5  | 23            | 4.5  | *0.793    | 79.6        | LOS F            | 13.3              | 98.3     | 1.00      | 0.94           | 1.15                | 11.4        |
| 2                            | T1   | All MCs   | 423          | 6.5  | 423           | 6.5  | 0.793     | 67.5        | LOS E            | 13.9              | 103.0    | 1.00      | 0.94           | 1.14                | 18.2        |
| 3                            | R2   | All MCs   | 7            | 28.6 | 7             | 28.6 | 0.793     | 74.3        | LOS F            | 13.9              | 103.0    | 1.00      | 0.94           | 1.14                | 12.0        |
| Approach                     |      |           | 454          | 6.7  | 454           | 6.7  | 0.793     | 68.2        | LOS E            | 13.9              | 103.0    | 1.00      | 0.94           | 1.14                | 17.7        |
| East: Henderson Rd (E)       |      |           |              |      |               |      |           |             |                  |                   |          |           |                |                     |             |
| 4                            | L2   | All MCs   | 177          | 2.4  | 177           | 2.4  | 0.327     | 6.0         | LOS A            | 2.2               | 15.9     | 0.10      | 0.30           | 0.10                | 40.0        |
| 5                            | T1   | All MCs   | 651          | 3.9  | 651           | 3.9  | 0.327     | 1.7         | LOS A            | 2.9               | 21.0     | 0.12      | 0.18           | 0.12                | 40.2        |
| 6                            | R2   | All MCs   | 782          | 6.3  | 782           | 6.3  | *0.675    | 17.4        | LOS B            | 9.2               | 67.7     | 0.74      | 0.79           | 0.74                | 25.0        |
| Approach                     |      |           | 1609         | 4.9  | 1609          | 4.9  | 0.675     | 9.8         | LOS A            | 9.2               | 67.7     | 0.42      | 0.49           | 0.42                | 29.4        |
| West: Henderson Rd (W)       |      |           |              |      |               |      |           |             |                  |                   |          |           |                |                     |             |
| 10                           | L2   | All MCs   | 343          | 6.4  | 343           | 6.4  | *0.851    | 89.0        | LOS F            | 17.1              | 126.3    | 0.97      | 0.92           | 1.13                | 12.0        |
| 11                           | T1   | All MCs   | 273          | 2.3  | 273           | 2.3  | 0.572     | 42.6        | LOS D            | 14.1              | 100.3    | 0.93      | 0.79           | 0.93                | 5.4         |
| Approach                     |      |           | 616          | 4.6  | 616           | 4.6  | 0.851     | 68.5        | LOS E            | 17.1              | 126.3    | 0.95      | 0.86           | 1.04                | 9.9         |
| All Vehicles                 |      |           | 2679         | 5.1  | 2679          | 5.1  | 0.851     | 33.2        | LOS C            | 17.1              | 126.3    | 0.64      | 0.65           | 0.69                | 19.3        |

Site Level of Service (LOS) Method: Delay (RTA NSW). Site LOS Method is specified in the Network Data dialog (Override Site Data tab).

Vehicle movement LOS values are based on average delay per movement.

Intersection and Approach LOS values are based on average delay for all vehicle movements.

Delay Model: SIDRA Standard (Control Delay: Geometric Delay is included).

Queue Model: SIDRA queue estimation methods are used for Back of Queue and Queue at Start of Green.

Gap-Acceptance Capacity Formula: SIDRA Standard (Akçelik M3D).

HV (%) values are calculated for All Movement Classes of All Heavy Vehicle Model Designation.

Arrival Flows used in performance calculations are adjusted to include any Initial Queued Demand and Upstream Capacity Constraint effects.

\* Critical Movement (Signal Timing)

| Pedestrian Movement Performance |          |           |             |                  |                       |        |           |                |             |              |             |
|---------------------------------|----------|-----------|-------------|------------------|-----------------------|--------|-----------|----------------|-------------|--------------|-------------|
| Mov ID                          | Crossing | Dem. Flow | Aver. Delay | Level of Service | AVERAGE BACK OF QUEUE |        | Prop. Que | Eff. Stop Rate | Travel Time | Travel Dist. | Aver. Speed |
|                                 |          | ped/h     | sec         |                  | [ Ped                 | Dist ] |           |                | sec         | m            | m/sec       |
|                                 |          |           |             |                  | ped                   | m      |           |                |             |              |             |
| South: Wyndham St (S)           |          |           |             |                  |                       |        |           |                |             |              |             |
| P1                              | Full     | 39        | 49.6        | LOS E            | 0.1                   | 0.1    | 0.91      | 0.91           | 66.3        | 20.0         | 0.30        |
| East: Henderson Rd (E)          |          |           |             |                  |                       |        |           |                |             |              |             |
| P2                              | Full     | 65        | 47.8        | LOS E            | 0.2                   | 0.2    | 0.89      | 0.89           | 64.5        | 20.0         | 0.31        |
| North: Wyndham St (N)           |          |           |             |                  |                       |        |           |                |             |              |             |
| P3                              | Full     | 65        | 49.6        | LOS E            | 0.2                   | 0.2    | 0.91      | 0.91           | 66.3        | 20.0         | 0.30        |
| West: Henderson Rd (W)          |          |           |             |                  |                       |        |           |                |             |              |             |
| P4                              | Full     | 134       | 48.0        | LOS E            | 0.4                   | 0.4    | 0.90      | 0.90           | 64.6        | 20.0         | 0.31        |
| All Pedestrians                 |          | 303       | 48.5        | LOS E            | 0.4                   | 0.4    | 0.90      | 0.90           | 65.2        | 20.0         | 0.31        |

Level of Service (LOS) Method: SIDRA Pedestrian LOS Method (Based on Average Delay)

Pedestrian movement LOS values are based on average delay per pedestrian movement.

Intersection LOS value for Pedestrians is based on average delay for all pedestrian movements.

**SIDRA INTERSECTION 9.1 | Copyright © 2000-2022 Akcelik and Associates Pty Ltd | sidrasolutions.com**

Organisation: AECOM AUSTRALIA PTY LTD | Licence: NETWORK / Enterprise Level 1 | Processed: Thursday, 13 July 2023 12:12:07 PM

Project: C:\Users\YeungMA\AECOM\ANZ-NAC-Sydney Metro-Sydney Metro C&SW Operational Monitoring - General\400\_Technical\432\_Traffic

Analysis\SIDRA Modelling\01 Models (Geometry Only)\Block 1\Rev1\_Review\08 SM C&SW\_WLO (Block 1)\_PS.sip9

# MOVEMENT SUMMARY

Site: WLO01 [WLO01 Botany Rd / Raglan St / Henderson Rd  
(Site Folder: Block 1 Model - 2023 PM Peak)]

Output produced by SIDRA INTERSECTION Version: 9.1.1.200

Network: WLO-N1 [WLO  
Network 1 (Network Folder:  
Block 1 Network - 2023 PM  
Peak)]

TCS 47

Site Category: (None)

Signals - EQUISAT (Fixed-Time/SCATS) Coordinated Cycle Time = 120 seconds (Network Site User-Given Phase Times)

| Vehicle Movement Performance |      |           |              |      |               |      |           |             |                  |                   |            |           |                |                     |             |
|------------------------------|------|-----------|--------------|------|---------------|------|-----------|-------------|------------------|-------------------|------------|-----------|----------------|---------------------|-------------|
| Mov ID                       | Turn | Mov Class | Demand Flows |      | Arrival Flows |      | Deg. Satn | Aver. Delay | Level of Service | 95% Back Of Queue |            | Prop. Que | Eff. Stop Rate | Aver. No. of Cycles | Aver. Speed |
|                              |      |           | [ Total HV ] | %    | [ Total HV ]  | %    |           |             |                  | [ Veh. veh        | [ Dist ] m |           |                |                     |             |
| South: Botany Rd (S)         |      |           |              |      |               |      |           |             |                  |                   |            |           |                |                     |             |
| 1                            | L2   | All MCs   | 653          | 6.1  | 653           | 6.1  | * 0.702   | 49.7        | LOS D            | 17.9              | 132.2      | 0.98      | 0.85           | 0.98                | 12.7        |
| Approach                     |      |           | 653          | 6.1  | 653           | 6.1  | 0.702     | 49.7        | LOS D            | 17.9              | 132.2      | 0.98      | 0.85           | 0.98                | 12.7        |
| East: Raglan St (E)          |      |           |              |      |               |      |           |             |                  |                   |            |           |                |                     |             |
| 4                            | L2   | All MCs   | 24           | 13.0 | 24            | 13.0 | * 0.785   | 91.0        | LOS F            | 7.8               | 56.9       | 1.00      | 0.93           | 1.21                | 4.4         |
| 5                            | T1   | All MCs   | 235          | 2.2  | 235           | 2.2  | 0.785     | 84.4        | LOS F            | 8.1               | 57.8       | 1.00      | 0.93           | 1.21                | 4.5         |
| Approach                     |      |           | 259          | 3.3  | 259           | 3.3  | 0.785     | 85.0        | LOS F            | 8.1               | 57.8       | 1.00      | 0.93           | 1.21                | 4.5         |
| North: Botany Rd (N)         |      |           |              |      |               |      |           |             |                  |                   |            |           |                |                     |             |
| 7                            | L2   | All MCs   | 64           | 16.4 | 64            | 16.4 | 0.389     | 12.0        | LOS A            | 10.6              | 77.5       | 0.37      | 0.37           | 0.37                | 35.9        |
| 8                            | T1   | All MCs   | 1035         | 3.9  | 1035          | 3.9  | 0.389     | 4.9         | LOS A            | 10.6              | 76.9       | 0.36      | 0.35           | 0.36                | 36.7        |
| 9                            | R2   | All MCs   | 728          | 1.4  | 728           | 1.4  | * 0.747   | 49.5        | LOS D            | 20.1              | 142.2      | 0.98      | 0.87           | 1.01                | 11.2        |
| Approach                     |      |           | 1827         | 3.3  | 1827          | 3.3  | 0.747     | 22.9        | LOS B            | 20.1              | 142.2      | 0.61      | 0.56           | 0.62                | 19.3        |
| West: Henderson Rd (W)       |      |           |              |      |               |      |           |             |                  |                   |            |           |                |                     |             |
| 11                           | T1   | All MCs   | 196          | 1.1  | 196           | 1.1  | 0.742     | 15.2        | LOS B            | 6.2               | 43.5       | 0.57      | 0.48           | 0.60                | 13.9        |
| 12                           | R2   | All MCs   | 48           | 2.2  | 48            | 2.2  | 0.742     | 66.2        | LOS E            | 3.3               | 23.6       | 1.00      | 0.77           | 1.06                | 4.1         |
| Approach                     |      |           | 244          | 1.3  | 244           | 1.3  | 0.742     | 25.3        | LOS B            | 6.2               | 43.5       | 0.65      | 0.54           | 0.69                | 9.5         |
| All Vehicles                 |      |           | 2983         | 3.8  | 2983          | 3.8  | 0.785     | 34.4        | LOS C            | 20.1              | 142.2      | 0.73      | 0.65           | 0.76                | 14.8        |

Site Level of Service (LOS) Method: Delay (RTA NSW). Site LOS Method is specified in the Network Data dialog (Override Site Data tab).

Vehicle movement LOS values are based on average delay per movement.

Intersection and Approach LOS values are based on average delay for all vehicle movements.

Delay Model: SIDRA Standard (Control Delay: Geometric Delay is included).

Queue Model: SIDRA queue estimation methods are used for Back of Queue and Queue at Start of Green.

Gap-Acceptance Capacity Formula: SIDRA Standard (Akçelik M3D).

HV (%) values are calculated for All Movement Classes of All Heavy Vehicle Model Designation.

Arrival Flows used in performance calculations are adjusted to include any Initial Queued Demand and Upstream Capacity Constraint effects.

\* Critical Movement (Signal Timing)

| Pedestrian Movement Performance |          |           |             |                  |                       |        |           |                |             |              |             |
|---------------------------------|----------|-----------|-------------|------------------|-----------------------|--------|-----------|----------------|-------------|--------------|-------------|
| Mov ID                          | Crossing | Dem. Flow | Aver. Delay | Level of Service | AVERAGE BACK OF QUEUE |        | Prop. Que | Eff. Stop Rate | Travel Time | Travel Dist. | Aver. Speed |
|                                 |          | ped/h     | sec         |                  | [ Ped                 | Dist ] |           |                | sec         | m            | m/sec       |
|                                 |          |           |             |                  | ped                   | m      |           |                |             |              |             |
| South: Botany Rd (S)            |          |           |             |                  |                       |        |           |                |             |              |             |
| P1                              | Full     | 62        | 49.6        | LOS E            | 0.2                   | 0.2    | 0.91      | 0.91           | 66.3        | 20.0         | 0.30        |
| East: Raglan St (E)             |          |           |             |                  |                       |        |           |                |             |              |             |
| P2                              | Full     | 96        | 49.7        | LOS E            | 0.3                   | 0.3    | 0.91      | 0.91           | 66.4        | 20.0         | 0.30        |
| North: Botany Rd (N)            |          |           |             |                  |                       |        |           |                |             |              |             |
| P3                              | Full     | 126       | 48.9        | LOS E            | 0.4                   | 0.4    | 0.90      | 0.90           | 65.5        | 20.0         | 0.31        |
| West: Henderson Rd (W)          |          |           |             |                  |                       |        |           |                |             |              |             |
| P4                              | Full     | 83        | 47.9        | LOS E            | 0.3                   | 0.3    | 0.89      | 0.89           | 64.5        | 20.0         | 0.31        |
| All Pedestrians                 |          | 367       | 49.0        | LOS E            | 0.4                   | 0.4    | 0.91      | 0.91           | 65.7        | 20.0         | 0.30        |

Level of Service (LOS) Method: SIDRA Pedestrian LOS Method (Based on Average Delay)

Pedestrian movement LOS values are based on average delay per pedestrian movement.

Intersection LOS value for Pedestrians is based on average delay for all pedestrian movements.

**SIDRA INTERSECTION 9.1 | Copyright © 2000-2022 Akcelik and Associates Pty Ltd | sidrasolutions.com**

Organisation: AECOM AUSTRALIA PTY LTD | Licence: NETWORK / Enterprise Level 1 | Processed: Thursday, 13 July 2023 12:12:11 PM

Project: C:\Users\YeungMA\AECOM\ANZ-NAC-Sydney Metro-Sydney Metro C&SW Operational Monitoring - General\400\_Technical\432\_Traffic

Analysis\SIDRA Modelling\01 Models (Geometry Only)\Block 1\Rev1\_Review\08 SM C&SW\_WLO (Block 1)\_PS.sip9

# MOVEMENT SUMMARY

Site: WLO02 [WLO02 Raglan St / Cope St (Site Folder: Block 1 Model - 2023 PM Peak)]

Output produced by SIDRA INTERSECTION Version: 9.1.1.200

Network: WLO-N1 [WLO Network 1 (Network Folder: Block 1 Network - 2023 PM Peak)]

NA  
Site Category: (None)  
Roundabout

| Vehicle Movement Performance |      |           |                       |     |                       |     |           |             |                  |                   |               |           |                |                     |                  |
|------------------------------|------|-----------|-----------------------|-----|-----------------------|-----|-----------|-------------|------------------|-------------------|---------------|-----------|----------------|---------------------|------------------|
| Mov ID                       | Turn | Mov Class | Demand Flows          |     | Arrival Flows         |     | Deg. Satn | Aver. Delay | Level of Service | 95% Back Of Queue |               | Prop. Que | Eff. Stop Rate | Aver. No. of Cycles | Aver. Speed km/h |
|                              |      |           | [ Total HV ]<br>veh/h | %   | [ Total HV ]<br>veh/h | %   |           |             |                  | [ Veh. veh        | [ Dist ]<br>m |           |                |                     |                  |
| East: Raglan St (E)          |      |           |                       |     |                       |     |           |             |                  |                   |               |           |                |                     |                  |
| 5                            | T1   | All MCs   | 185                   | 5.1 | 185                   | 5.1 | 0.186     | 4.3         | LOS A            | 1.2               | 8.8           | 0.31      | 0.46           | 0.31                | 40.0             |
| 6                            | R2   | All MCs   | 31                    | 3.4 | 31                    | 3.4 | 0.186     | 7.4         | LOS A            | 1.2               | 8.8           | 0.31      | 0.46           | 0.31                | 41.9             |
| 6u                           | U    | All MCs   | 3                     | 0.0 | 3                     | 0.0 | 0.186     | 8.8         | LOS A            | 1.2               | 8.8           | 0.31      | 0.46           | 0.31                | 42.4             |
| Approach                     |      |           | 219                   | 4.8 | 219                   | 4.8 | 0.186     | 4.8         | LOS A            | 1.2               | 8.8           | 0.31      | 0.46           | 0.31                | 40.5             |
| North: Cope St (N)           |      |           |                       |     |                       |     |           |             |                  |                   |               |           |                |                     |                  |
| 7                            | L2   | All MCs   | 25                    | 0.0 | 25                    | 0.0 | 0.099     | 5.3         | LOS A            | 0.6               | 4.2           | 0.44      | 0.59           | 0.44                | 40.6             |
| 9                            | R2   | All MCs   | 75                    | 0.0 | 75                    | 0.0 | 0.099     | 8.3         | LOS A            | 0.6               | 4.2           | 0.44      | 0.59           | 0.44                | 35.9             |
| 9u                           | U    | All MCs   | 1                     | 0.0 | 1                     | 0.0 | 0.099     | 9.7         | LOS A            | 0.6               | 4.2           | 0.44      | 0.59           | 0.44                | 39.6             |
| Approach                     |      |           | 101                   | 0.0 | 101                   | 0.0 | 0.099     | 7.5         | LOS A            | 0.6               | 4.2           | 0.44      | 0.59           | 0.44                | 37.8             |
| West: Raglan St (W)          |      |           |                       |     |                       |     |           |             |                  |                   |               |           |                |                     |                  |
| 10                           | L2   | All MCs   | 57                    | 0.0 | 57                    | 0.0 | 0.202     | 3.9         | LOS A            | 1.1               | 8.4           | 0.15      | 0.44           | 0.15                | 39.7             |
| 11                           | T1   | All MCs   | 204                   | 6.2 | 204                   | 6.2 | 0.202     | 3.8         | LOS A            | 1.1               | 8.4           | 0.15      | 0.44           | 0.15                | 41.2             |
| 12u                          | U    | All MCs   | 12                    | 0.0 | 12                    | 0.0 | 0.202     | 8.4         | LOS A            | 1.1               | 8.4           | 0.15      | 0.44           | 0.15                | 28.7             |
| Approach                     |      |           | 273                   | 4.6 | 273                   | 4.6 | 0.202     | 4.0         | LOS A            | 1.1               | 8.4           | 0.15      | 0.44           | 0.15                | 40.7             |
| All Vehicles                 |      |           | 593                   | 3.9 | 593                   | 3.9 | 0.202     | 4.9         | LOS A            | 1.2               | 8.8           | 0.26      | 0.47           | 0.26                | 40.1             |

Site Level of Service (LOS) Method: Delay (RTA NSW). Site LOS Method is specified in the Network Data dialog (Override Site Data tab).

Vehicle movement LOS values are based on average delay per movement.

Intersection and Approach LOS values are based on average delay for all vehicle movements.

Roundabout Capacity Model: SIDRA Standard.

Delay Model: SIDRA Standard (Control Delay: Geometric Delay is included).

Queue Model: SIDRA queue estimation methods are used for Back of Queue and Queue at Start of Gap.

Gap-Acceptance Capacity Formula: SIDRA Standard (Akçelik M3D).

HV (%) values are calculated for All Movement Classes of All Heavy Vehicle Model Designation.

Arrival Flows used in performance calculations are adjusted to include any Initial Queued Demand and Upstream Capacity Constraint effects.



---

**SIDRA INTERSECTION 9.1 | Copyright © 2000-2022 Akcelik and Associates Pty Ltd | sidrasolutions.com**

Organisation: AECOM AUSTRALIA PTY LTD | Licence: NETWORK / Enterprise Level 1 | Processed: Thursday, 13 July 2023 12:12:11 PM

Project: C:\Users\Yeung\AECOMANZ-NAC-Sydney Metro-Sydney Metro C&SW Operational Monitoring - General\400\_Technical\432\_Traffic  
Analysis\SIDRA Modelling\01 Models (Geometry Only)\Block 1\Rev1\\_Review\08 SM C&SW\_WLO (Block 1)\_PS.sip9

# MOVEMENT SUMMARY

Site: WLO03 [WLO03 Botany Rd / Wellington St / Buckland St  
(Site Folder: Block 1 Model - 2023 PM Peak)]

Output produced by SIDRA INTERSECTION Version: 9.1.1.200

Network: WLO-N1 [WLO  
Network 1 (Network Folder:  
Block 1 Network - 2023 PM  
Peak)]

TCS 137

Site Category: (None)

Signals - EQUISAT (Fixed-Time/SCATS) Coordinated Cycle Time = 120 seconds (Network Site User-Given Phase Times)

| Vehicle Movement Performance |      |           |                       |     |                       |     |           |             |                  |                   |               |           |                |                     |             |
|------------------------------|------|-----------|-----------------------|-----|-----------------------|-----|-----------|-------------|------------------|-------------------|---------------|-----------|----------------|---------------------|-------------|
| Mov ID                       | Turn | Mov Class | Demand Flows          |     | Arrival Flows         |     | Deg. Satn | Aver. Delay | Level of Service | 95% Back Of Queue |               | Prop. Que | Eff. Stop Rate | Aver. No. of Cycles | Aver. Speed |
|                              |      |           | [ Total HV ]<br>veh/h | %   | [ Total HV ]<br>veh/h | %   |           |             |                  | [ Veh. veh        | [ Dist ]<br>m |           |                |                     |             |
| South: Botany Rd (S)         |      |           |                       |     |                       |     |           |             |                  |                   |               |           |                |                     |             |
| 2                            | T1   | All MCs   | 602                   | 6.3 | 602                   | 6.3 | 0.332     | 5.3         | LOS A            | 8.7               | 64.1          | 0.37      | 0.35           | 0.37                | 39.5        |
| 3                            | R2   | All MCs   | 66                    | 0.0 | 66                    | 0.0 | 0.332     | 12.7        | LOS A            | 4.5               | 32.6          | 0.39      | 0.44           | 0.39                | 36.9        |
| Approach                     |      |           | 668                   | 5.7 | 668                   | 5.7 | 0.332     | 6.1         | LOS A            | 8.7               | 64.1          | 0.37      | 0.36           | 0.37                | 39.2        |
| East: Wellington St (E)      |      |           |                       |     |                       |     |           |             |                  |                   |               |           |                |                     |             |
| 4                            | L2   | All MCs   | 66                    | 3.2 | 66                    | 3.2 | 0.317     | 58.2        | LOS E            | 3.7               | 26.4          | 0.96      | 0.76           | 0.96                | 15.4        |
| 6                            | R2   | All MCs   | 39                    | 2.7 | 39                    | 2.7 | 0.211     | 56.8        | LOS E            | 2.1               | 15.2          | 0.94      | 0.74           | 0.94                | 4.2         |
| Approach                     |      |           | 105                   | 3.0 | 105                   | 3.0 | 0.317     | 57.7        | LOS E            | 3.7               | 26.4          | 0.95      | 0.75           | 0.95                | 12.1        |
| North: Botany Rd (N)         |      |           |                       |     |                       |     |           |             |                  |                   |               |           |                |                     |             |
| 7                            | L2   | All MCs   | 29                    | 7.1 | 29                    | 7.1 | *0.399    | 8.1         | LOS A            | 6.2               | 44.8          | 0.21      | 0.21           | 0.21                | 43.1        |
| 8                            | T1   | All MCs   | 1087                  | 4.0 | 1087                  | 4.0 | 0.399     | 2.4         | LOS A            | 6.2               | 44.8          | 0.21      | 0.20           | 0.21                | 46.9        |
| Approach                     |      |           | 1117                  | 4.1 | 1117                  | 4.1 | 0.399     | 2.5         | LOS A            | 6.2               | 44.8          | 0.21      | 0.20           | 0.21                | 46.8        |
| West: Buckland St (W)        |      |           |                       |     |                       |     |           |             |                  |                   |               |           |                |                     |             |
| 10                           | L2   | All MCs   | 9                     | 0.0 | 9                     | 0.0 | 0.246     | 54.3        | LOS D            | 3.6               | 25.9          | 0.92      | 0.72           | 0.92                | 5.4         |
| 11                           | T1   | All MCs   | 60                    | 1.8 | 60                    | 1.8 | *0.246    | 49.0        | LOS D            | 3.6               | 25.9          | 0.92      | 0.72           | 0.92                | 5.4         |
| 12                           | R2   | All MCs   | 18                    | 0.0 | 18                    | 0.0 | 0.090     | 55.5        | LOS D            | 1.0               | 6.7           | 0.92      | 0.69           | 0.92                | 15.7        |
| Approach                     |      |           | 87                    | 1.2 | 87                    | 1.2 | 0.246     | 50.9        | LOS D            | 3.6               | 25.9          | 0.92      | 0.71           | 0.92                | 8.3         |
| All Vehicles                 |      |           | 1978                  | 4.4 | 1978                  | 4.4 | 0.399     | 8.8         | LOS A            | 8.7               | 64.1          | 0.33      | 0.31           | 0.33                | 38.5        |

Site Level of Service (LOS) Method: Delay (RTA NSW). Site LOS Method is specified in the Network Data dialog (Override Site Data tab).

Vehicle movement LOS values are based on average delay per movement.

Intersection and Approach LOS values are based on average delay for all vehicle movements.

Delay Model: SIDRA Standard (Control Delay: Geometric Delay is included).

Queue Model: SIDRA queue estimation methods are used for Back of Queue and Queue at Start of Green.

Gap-Acceptance Capacity Formula: SIDRA Standard (Akçelik M3D).

HV (%) values are calculated for All Movement Classes of All Heavy Vehicle Model Designation.

Arrival Flows used in performance calculations are adjusted to include any Initial Queued Demand and Upstream Capacity Constraint effects.

\* Critical Movement (Signal Timing)

| Pedestrian Movement Performance |          |           |             |                  |                       |        |           |                |             |              |             |
|---------------------------------|----------|-----------|-------------|------------------|-----------------------|--------|-----------|----------------|-------------|--------------|-------------|
| Mov ID                          | Crossing | Dem. Flow | Aver. Delay | Level of Service | AVERAGE BACK OF QUEUE |        | Prop. Que | Eff. Stop Rate | Travel Time | Travel Dist. | Aver. Speed |
|                                 |          | ped/h     | sec         |                  | [ Ped                 | Dist ] |           |                | sec         | m            | m/sec       |
|                                 |          |           |             |                  | ped                   | m      |           |                |             |              |             |
| South: Botany Rd (S)            |          |           |             |                  |                       |        |           |                |             |              |             |
| P1                              | Full     | 60        | 48.7        | LOS E            | 0.2                   | 0.2    | 0.90      | 0.90           | 65.4        | 20.0         | 0.31        |
| East: Wellington St (E)         |          |           |             |                  |                       |        |           |                |             |              |             |
| P2                              | Full     | 102       | 48.8        | LOS E            | 0.3                   | 0.3    | 0.90      | 0.90           | 65.5        | 20.0         | 0.31        |
| North: Botany Rd (N)            |          |           |             |                  |                       |        |           |                |             |              |             |
| P3                              | Full     | 48        | 48.7        | LOS E            | 0.1                   | 0.1    | 0.90      | 0.90           | 65.4        | 20.0         | 0.31        |
| West: Buckland St (W)           |          |           |             |                  |                       |        |           |                |             |              |             |
| P4                              | Full     | 84        | 48.8        | LOS E            | 0.3                   | 0.3    | 0.90      | 0.90           | 65.4        | 20.0         | 0.31        |
| All Pedestrians                 |          | 295       | 48.8        | LOS E            | 0.3                   | 0.3    | 0.90      | 0.90           | 65.4        | 20.0         | 0.31        |

Level of Service (LOS) Method: SIDRA Pedestrian LOS Method (Based on Average Delay)

Pedestrian movement LOS values are based on average delay per pedestrian movement.

Intersection LOS value for Pedestrians is based on average delay for all pedestrian movements.

**SIDRA INTERSECTION 9.1 | Copyright © 2000-2022 Akcelik and Associates Pty Ltd | sidrasolutions.com**

Organisation: AECOM AUSTRALIA PTY LTD | Licence: NETWORK / Enterprise Level 1 | Processed: Thursday, 13 July 2023 12:12:11 PM  
 Project: C:\Users\YeungMAECOMANZ-NAC-Sydney Metro-Sydney Metro C&SW Operational Monitoring - General\400\_Technical\432\_Traffic Analysis\SIDRA Modelling\01 Models (Geometry Only)\Block 1\Rev1\_Review\08 SM C&SW\_WLO (Block 1)\_PS.sip9

# MOVEMENT SUMMARY

Site: WLO04 [WLO04 Cope St / Wellington St (Site Folder: Block 1 Model - 2023 PM Peak)]

Output produced by SIDRA INTERSECTION Version: 9.1.1.200

Network: WLO-N1 [WLO Network 1 (Network Folder: Block 1 Network - 2023 PM Peak)]

NA  
Site Category: (None)  
Roundabout

| Vehicle Movement Performance |      |           |                       |     |                       |     |           |             |                  |                   |             |           |                |                     |                  |
|------------------------------|------|-----------|-----------------------|-----|-----------------------|-----|-----------|-------------|------------------|-------------------|-------------|-----------|----------------|---------------------|------------------|
| Mov ID                       | Turn | Mov Class | Demand Flows          |     | Arrival Flows         |     | Deg. Satn | Aver. Delay | Level of Service | 95% Back Of Queue |             | Prop. Que | Eff. Stop Rate | Aver. No. of Cycles | Aver. Speed km/h |
|                              |      |           | [ Total HV ]<br>veh/h | %   | [ Total HV ]<br>veh/h | %   |           |             |                  | [ Veh. veh        | Dist ]<br>m |           |                |                     |                  |
| South: Cope St (S)           |      |           |                       |     |                       |     |           |             |                  |                   |             |           |                |                     |                  |
| 1                            | L2   | All MCs   | 27                    | 0.0 | 27                    | 0.0 | 0.036     | 4.5         | LOS A            | 0.2               | 1.4         | 0.26      | 0.52           | 0.26                | 33.4             |
| 3                            | R2   | All MCs   | 11                    | 0.0 | 11                    | 0.0 | 0.036     | 7.2         | LOS A            | 0.2               | 1.4         | 0.26      | 0.52           | 0.26                | 35.8             |
| 3u                           | U    | All MCs   | 250.0                 |     | 250.0                 |     | 0.036     | 9.2         | LOS A            | 0.2               | 1.4         | 0.26      | 0.52           | 0.26                | 32.0             |
| Approach                     |      |           | 40                    | 2.6 | 40                    | 2.6 | 0.036     | 5.4         | LOS A            | 0.2               | 1.4         | 0.26      | 0.52           | 0.26                | 34.1             |
| East: Wellington St (E)      |      |           |                       |     |                       |     |           |             |                  |                   |             |           |                |                     |                  |
| 4                            | L2   | All MCs   | 19                    | 5.6 | 19                    | 5.6 | 0.076     | 4.2         | LOS A            | 0.5               | 3.3         | 0.17      | 0.43           | 0.17                | 37.3             |
| 5                            | T1   | All MCs   | 75                    | 1.4 | 75                    | 1.4 | 0.076     | 4.0         | LOS A            | 0.5               | 3.3         | 0.17      | 0.43           | 0.17                | 34.0             |
| 6u                           | U    | All MCs   | 100.0                 |     | 100.0                 |     | 0.076     | 9.4         | LOS A            | 0.5               | 3.3         | 0.17      | 0.43           | 0.17                | 26.9             |
| Approach                     |      |           | 95                    | 3.3 | 95                    | 3.3 | 0.076     | 4.1         | LOS A            | 0.5               | 3.3         | 0.17      | 0.43           | 0.17                | 34.9             |
| West: Wellington St (W)      |      |           |                       |     |                       |     |           |             |                  |                   |             |           |                |                     |                  |
| 11                           | T1   | All MCs   | 121                   | 0.9 | 121                   | 0.9 | 0.111     | 3.5         | LOS A            | 0.6               | 4.1         | 0.08      | 0.48           | 0.08                | 35.5             |
| 12                           | R2   | All MCs   | 31                    | 6.9 | 31                    | 6.9 | 0.111     | 6.5         | LOS A            | 0.6               | 4.1         | 0.08      | 0.48           | 0.08                | 34.5             |
| 12u                          | U    | All MCs   | 616.7                 |     | 616.7                 |     | 0.111     | 7.9         | LOS A            | 0.6               | 4.1         | 0.08      | 0.48           | 0.08                | 28.1             |
| Approach                     |      |           | 158                   | 2.7 | 158                   | 2.7 | 0.111     | 4.3         | LOS A            | 0.6               | 4.1         | 0.08      | 0.48           | 0.08                | 35.1             |
| All Vehicles                 |      |           | 293                   | 2.9 | 293                   | 2.9 | 0.111     | 4.4         | LOS A            | 0.6               | 4.1         | 0.13      | 0.47           | 0.13                | 34.9             |

Site Level of Service (LOS) Method: Delay (RTA NSW). Site LOS Method is specified in the Network Data dialog (Override Site Data tab).

Vehicle movement LOS values are based on average delay per movement.

Intersection and Approach LOS values are based on average delay for all vehicle movements.

Roundabout Capacity Model: SIDRA Standard.

Delay Model: SIDRA Standard (Control Delay: Geometric Delay is included).

Queue Model: SIDRA queue estimation methods are used for Back of Queue and Queue at Start of Gap.

Gap-Acceptance Capacity Formula: SIDRA Standard (Akçelik M3D).

HV (%) values are calculated for All Movement Classes of All Heavy Vehicle Model Designation.

Arrival Flows used in performance calculations are adjusted to include any Initial Queued Demand and Upstream Capacity Constraint effects.

---

**SIDRA INTERSECTION 9.1 | Copyright © 2000-2022 Akcelik and Associates Pty Ltd | sidrasolutions.com**

Organisation: AECOM AUSTRALIA PTY LTD | Licence: NETWORK / Enterprise Level 1 | Processed: Thursday, 13 July 2023 12:12:11 PM

Project: C:\Users\Yeung\AECOMANZ-NAC-Sydney Metro-Sydney Metro C&SW Operational Monitoring - General\400\_Technical\432\_Traffic  
Analysis\SIDRA Modelling\01 Models (Geometry Only)\Block 1\Rev1\\_Review\08 SM C&SW\_WLO (Block 1)\_PS.sip9

# MOVEMENT SUMMARY

Site: WLO05 [WLO05 Wyndham St / Henderson Rd (Site Folder: Block 1 Model - 2023 PM Peak)]

Output produced by SIDRA INTERSECTION Version: 9.1.1.200

Network: WLO-N1 [WLO Network 1 (Network Folder: Block 1 Network - 2023 PM Peak)]

TCS 55

Site Category: (None)

Signals - EQUISAT (Fixed-Time/SCATS) Coordinated Cycle Time = 120 seconds (Network Site User-Given Phase Times)

| Vehicle Movement Performance |      |           |              |      |               |      |           |             |                  |                   |          |           |                |                     |             |
|------------------------------|------|-----------|--------------|------|---------------|------|-----------|-------------|------------------|-------------------|----------|-----------|----------------|---------------------|-------------|
| Mov ID                       | Turn | Mov Class | Demand Flows |      | Arrival Flows |      | Deg. Satn | Aver. Delay | Level of Service | 95% Back Of Queue |          | Prop. Que | Eff. Stop Rate | Aver. No. of Cycles | Aver. Speed |
|                              |      |           | [ Total HV ] | %    | [ Total HV ]  | %    |           |             |                  | [ Veh. veh        | Dist ] m |           |                |                     |             |
| South: Wyndham St (S)        |      |           |              |      |               |      |           |             |                  |                   |          |           |                |                     |             |
| 1                            | L2   | All MCs   | 18           | 0.0  | 18            | 0.0  | *0.848    | 85.5        | LOS F            | 16.7              | 118.1    | 1.00      | 1.01           | 1.21                | 11.1        |
| 2                            | T1   | All MCs   | 517          | 1.4  | 517           | 1.4  | 0.848     | 73.3        | LOS F            | 17.3              | 123.3    | 1.00      | 1.01           | 1.21                | 17.7        |
| 3                            | R2   | All MCs   | 6            | 16.7 | 6             | 16.7 | 0.848     | 79.9        | LOS F            | 17.3              | 123.3    | 1.00      | 1.01           | 1.21                | 11.5        |
| Approach                     |      |           | 541          | 1.6  | 541           | 1.6  | 0.848     | 73.8        | LOS F            | 17.3              | 123.3    | 1.00      | 1.01           | 1.21                | 17.4        |
| East: Henderson Rd (E)       |      |           |              |      |               |      |           |             |                  |                   |          |           |                |                     |             |
| 4                            | L2   | All MCs   | 194          | 2.2  | 194           | 2.2  | 0.375     | 9.4         | LOS A            | 6.6               | 46.5     | 0.27      | 0.41           | 0.27                | 35.8        |
| 5                            | T1   | All MCs   | 738          | 1.0  | 738           | 1.0  | 0.375     | 3.6         | LOS A            | 6.6               | 46.5     | 0.23      | 0.27           | 0.23                | 34.6        |
| 6                            | R2   | All MCs   | 638          | 6.9  | 638           | 6.9  | *0.568    | 16.7        | LOS B            | 6.6               | 49.2     | 0.70      | 0.76           | 0.70                | 25.5        |
| Approach                     |      |           | 1569         | 3.6  | 1569          | 3.6  | 0.568     | 9.6         | LOS A            | 6.6               | 49.2     | 0.43      | 0.48           | 0.43                | 29.3        |
| West: Henderson Rd (W)       |      |           |              |      |               |      |           |             |                  |                   |          |           |                |                     |             |
| 10                           | L2   | All MCs   | 295          | 1.8  | 295           | 1.8  | *0.776    | 83.8        | LOS F            | 13.8              | 98.1     | 0.97      | 0.86           | 1.07                | 12.5        |
| 11                           | T1   | All MCs   | 256          | 0.8  | 256           | 0.8  | 0.567     | 44.1        | LOS D            | 13.3              | 94.0     | 0.94      | 0.79           | 0.94                | 5.2         |
| Approach                     |      |           | 551          | 1.3  | 551           | 1.3  | 0.776     | 65.4        | LOS E            | 13.8              | 98.1     | 0.96      | 0.83           | 1.01                | 9.9         |
| All Vehicles                 |      |           | 2661         | 2.7  | 2661          | 2.7  | 0.848     | 34.2        | LOS C            | 17.3              | 123.3    | 0.65      | 0.66           | 0.71                | 19.2        |

Site Level of Service (LOS) Method: Delay (RTA NSW). Site LOS Method is specified in the Network Data dialog (Override Site Data tab).

Vehicle movement LOS values are based on average delay per movement.

Intersection and Approach LOS values are based on average delay for all vehicle movements.

Delay Model: SIDRA Standard (Control Delay: Geometric Delay is included).

Queue Model: SIDRA queue estimation methods are used for Back of Queue and Queue at Start of Green.

Gap-Acceptance Capacity Formula: SIDRA Standard (Akçelik M3D).

HV (%) values are calculated for All Movement Classes of All Heavy Vehicle Model Designation.

Arrival Flows used in performance calculations are adjusted to include any Initial Queued Demand and Upstream Capacity Constraint effects.

\* Critical Movement (Signal Timing)

| Pedestrian Movement Performance |          |           |             |                  |                       |        |           |                |             |              |             |
|---------------------------------|----------|-----------|-------------|------------------|-----------------------|--------|-----------|----------------|-------------|--------------|-------------|
| Mov ID                          | Crossing | Dem. Flow | Aver. Delay | Level of Service | AVERAGE BACK OF QUEUE |        | Prop. Que | Eff. Stop Rate | Travel Time | Travel Dist. | Aver. Speed |
|                                 |          | ped/h     | sec         |                  | [ Ped                 | Dist ] |           |                | sec         | m            | m/sec       |
|                                 |          |           |             |                  | ped                   | m      |           |                |             |              |             |
| South: Wyndham St (S)           |          |           |             |                  |                       |        |           |                |             |              |             |
| P1                              | Full     | 53        | 49.6        | LOS E            | 0.2                   | 0.2    | 0.91      | 0.91           | 66.3        | 20.0         | 0.30        |
| East: Henderson Rd (E)          |          |           |             |                  |                       |        |           |                |             |              |             |
| P2                              | Full     | 56        | 47.8        | LOS E            | 0.2                   | 0.2    | 0.89      | 0.89           | 64.5        | 20.0         | 0.31        |
| North: Wyndham St (N)           |          |           |             |                  |                       |        |           |                |             |              |             |
| P3                              | Full     | 82        | 49.7        | LOS E            | 0.3                   | 0.3    | 0.91      | 0.91           | 66.3        | 20.0         | 0.30        |
| West: Henderson Rd (W)          |          |           |             |                  |                       |        |           |                |             |              |             |
| P4                              | Full     | 138       | 48.0        | LOS E            | 0.4                   | 0.4    | 0.90      | 0.90           | 64.6        | 20.0         | 0.31        |
| All Pedestrians                 |          | 328       | 48.6        | LOS E            | 0.4                   | 0.4    | 0.90      | 0.90           | 65.3        | 20.0         | 0.31        |

Level of Service (LOS) Method: SIDRA Pedestrian LOS Method (Based on Average Delay)

Pedestrian movement LOS values are based on average delay per pedestrian movement.

Intersection LOS value for Pedestrians is based on average delay for all pedestrian movements.

**SIDRA INTERSECTION 9.1 | Copyright © 2000-2022 Akcelik and Associates Pty Ltd | sidrasolutions.com**

Organisation: AECOM AUSTRALIA PTY LTD | Licence: NETWORK / Enterprise Level 1 | Processed: Thursday, 13 July 2023 12:12:11 PM

Project: C:\Users\YeungMA\AECOM\ANZ-NAC-Sydney Metro-Sydney Metro C&SW Operational Monitoring - General\400\_Technical\432\_Traffic

Analysis\SIDRA Modelling\01 Models (Geometry Only)\Block 1\Rev1\_Review\08 SM C&SW\_WLO (Block 1)\_PS.sip9

# MOVEMENT SUMMARY

Site: WLO01 [WLO01 Botany Rd / Raglan St / Henderson Rd  
(Site Folder: Block 1 Model - 2023 Weekend Peak)]

Output produced by SIDRA INTERSECTION Version: 9.1.1.200

Network: WLO-N1 [WLO  
Network 1 (Network Folder:  
Block 1 Network - 2023  
Weekend Peak)]

TCS 47

Site Category: (None)

Signals - EQUISAT (Fixed-Time/SCATS) Coordinated Cycle Time = 120 seconds (Network Site User-Given Phase Times)

| Vehicle Movement Performance |      |           |                       |      |                       |      |           |             |                  |                   |               |           |                |                     |             |
|------------------------------|------|-----------|-----------------------|------|-----------------------|------|-----------|-------------|------------------|-------------------|---------------|-----------|----------------|---------------------|-------------|
| Mov ID                       | Turn | Mov Class | Demand Flows          |      | Arrival Flows         |      | Deg. Satn | Aver. Delay | Level of Service | 95% Back Of Queue |               | Prop. Que | Eff. Stop Rate | Aver. No. of Cycles | Aver. Speed |
|                              |      |           | [ Total HV ]<br>veh/h | %    | [ Total HV ]<br>veh/h | %    |           |             |                  | [ Veh. veh        | [ Dist ]<br>m |           |                |                     |             |
| South: Botany Rd (S)         |      |           |                       |      |                       |      |           |             |                  |                   |               |           |                |                     |             |
| 1                            | L2   | All MCs   | 512                   | 3.1  | 512                   | 3.1  | *0.761    | 60.4        | LOS E            | 15.2              | 109.5         | 1.00      | 0.90           | 1.07                | 11.0        |
| Approach                     |      |           | 512                   | 3.1  | 512                   | 3.1  | 0.761     | 60.4        | LOS E            | 15.2              | 109.5         | 1.00      | 0.90           | 1.07                | 11.0        |
| East: Raglan St (E)          |      |           |                       |      |                       |      |           |             |                  |                   |               |           |                |                     |             |
| 4                            | L2   | All MCs   | 28                    | 11.1 | 28                    | 11.1 | *0.733    | 84.0        | LOS F            | 8.1               | 58.9          | 1.00      | 0.89           | 1.13                | 4.8         |
| 5                            | T1   | All MCs   | 245                   | 3.4  | 245                   | 3.4  | 0.733     | 77.4        | LOS F            | 8.1               | 58.5          | 1.00      | 0.89           | 1.13                | 4.9         |
| Approach                     |      |           | 274                   | 4.2  | 274                   | 4.2  | 0.733     | 78.1        | LOS F            | 8.1               | 58.9          | 1.00      | 0.89           | 1.13                | 4.9         |
| North: Botany Rd (N)         |      |           |                       |      |                       |      |           |             |                  |                   |               |           |                |                     |             |
| 7                            | L2   | All MCs   | 86                    | 6.1  | 86                    | 6.1  | 0.122     | 13.4        | LOS A            | 2.7               | 20.1          | 0.33      | 0.48           | 0.33                | 32.1        |
| 8                            | T1   | All MCs   | 828                   | 4.4  | 828                   | 4.4  | 0.608     | 11.3        | LOS A            | 21.4              | 155.8         | 0.52      | 0.49           | 0.52                | 31.5        |
| 9                            | R2   | All MCs   | 646                   | 2.3  | 646                   | 2.3  | *0.822    | 54.8        | LOS D            | 19.4              | 138.6         | 0.99      | 0.92           | 1.13                | 10.5        |
| Approach                     |      |           | 1561                  | 3.6  | 1561                  | 3.6  | 0.822     | 29.5        | LOS C            | 21.4              | 155.8         | 0.70      | 0.67           | 0.76                | 17.4        |
| West: Henderson Rd (W)       |      |           |                       |      |                       |      |           |             |                  |                   |               |           |                |                     |             |
| 11                           | T1   | All MCs   | 243                   | 0.9  | 243                   | 0.9  | 0.619     | 10.7        | LOS A            | 3.9               | 27.7          | 0.34      | 0.28           | 0.34                | 16.8        |
| 12                           | R2   | All MCs   | 39                    | 2.7  | 39                    | 2.7  | 0.619     | 57.5        | LOS E            | 3.9               | 27.7          | 0.89      | 0.73           | 0.91                | 5.4         |
| Approach                     |      |           | 282                   | 1.1  | 282                   | 1.1  | 0.619     | 17.2        | LOS B            | 3.9               | 27.7          | 0.41      | 0.34           | 0.42                | 13.0        |
| All Vehicles                 |      |           | 2628                  | 3.3  | 2628                  | 3.3  | 0.822     | 39.2        | LOS C            | 21.4              | 155.8         | 0.76      | 0.70           | 0.82                | 13.5        |

Site Level of Service (LOS) Method: Delay (RTA NSW). Site LOS Method is specified in the Network Data dialog (Override Site Data tab).

Vehicle movement LOS values are based on average delay per movement.

Intersection and Approach LOS values are based on average delay for all vehicle movements.

Delay Model: SIDRA Standard (Control Delay: Geometric Delay is included).

Queue Model: SIDRA queue estimation methods are used for Back of Queue and Queue at Start of Green.

Gap-Acceptance Capacity Formula: SIDRA Standard (Akçelik M3D).

HV (%) values are calculated for All Movement Classes of All Heavy Vehicle Model Designation.

Arrival Flows used in performance calculations are adjusted to include any Initial Queued Demand and Upstream Capacity Constraint effects.

\* Critical Movement (Signal Timing)



| Pedestrian Movement Performance |          |           |             |                  |                       |        |           |                |             |              |             |
|---------------------------------|----------|-----------|-------------|------------------|-----------------------|--------|-----------|----------------|-------------|--------------|-------------|
| Mov ID                          | Crossing | Dem. Flow | Aver. Delay | Level of Service | AVERAGE BACK OF QUEUE |        | Prop. Que | Eff. Stop Rate | Travel Time | Travel Dist. | Aver. Speed |
|                                 |          | ped/h     | sec         |                  | [ Ped                 | Dist ] |           |                | sec         | m            | m/sec       |
|                                 |          |           |             |                  | ped                   | m      |           |                |             |              |             |
| South: Botany Rd (S)            |          |           |             |                  |                       |        |           |                |             |              |             |
| P1                              | Full     | 22        | 49.5        | LOS E            | 0.1                   | 0.1    | 0.91      | 0.91           | 66.2        | 20.0         | 0.30        |
| East: Raglan St (E)             |          |           |             |                  |                       |        |           |                |             |              |             |
| P2                              | Full     | 54        | 49.6        | LOS E            | 0.2                   | 0.2    | 0.91      | 0.91           | 66.3        | 20.0         | 0.30        |
| North: Botany Rd (N)            |          |           |             |                  |                       |        |           |                |             |              |             |
| P3                              | Full     | 77        | 48.8        | LOS E            | 0.2                   | 0.2    | 0.90      | 0.90           | 65.4        | 20.0         | 0.31        |
| West: Henderson Rd (W)          |          |           |             |                  |                       |        |           |                |             |              |             |
| P4                              | Full     | 77        | 47.9        | LOS E            | 0.2                   | 0.2    | 0.89      | 0.89           | 64.5        | 20.0         | 0.31        |
| All Pedestrians                 |          | 229       | 48.7        | LOS E            | 0.2                   | 0.2    | 0.90      | 0.90           | 65.4        | 20.0         | 0.31        |

Level of Service (LOS) Method: SIDRA Pedestrian LOS Method (Based on Average Delay)

Pedestrian movement LOS values are based on average delay per pedestrian movement.

Intersection LOS value for Pedestrians is based on average delay for all pedestrian movements.

**SIDRA INTERSECTION 9.1 | Copyright © 2000-2022 Akcelik and Associates Pty Ltd | sidrasolutions.com**

Organisation: AECOM AUSTRALIA PTY LTD | Licence: NETWORK / Enterprise Level 1 | Processed: Thursday, 13 July 2023 12:12:16 PM  
 Project: C:\Users\YeungMA\AECOM\ANZ-NAC-Sydney Metro-Sydney Metro C&SW Operational Monitoring - General\400\_Technical\432\_Traffic Analysis\SIDRA Modelling\01 Models (Geometry Only)\Block 1\Rev1\_Review\08 SM C&SW\_WLO (Block 1)\_PS.sip9

# MOVEMENT SUMMARY

Site: WLO02 [WLO02 Raglan St / Cope St (Site Folder: Block 1 Model - 2023 Weekend Peak)]

Output produced by SIDRA INTERSECTION Version: 9.1.1.200

Network: WLO-N1 [WLO Network 1 (Network Folder: Block 1 Network - 2023 Weekend Peak)]

NA  
Site Category: (None)  
Roundabout

| Vehicle Movement Performance |      |           |                       |     |                       |     |           |             |                  |                   |             |           |                |                     |                  |
|------------------------------|------|-----------|-----------------------|-----|-----------------------|-----|-----------|-------------|------------------|-------------------|-------------|-----------|----------------|---------------------|------------------|
| Mov ID                       | Turn | Mov Class | Demand Flows          |     | Arrival Flows         |     | Deg. Satn | Aver. Delay | Level of Service | 95% Back Of Queue |             | Prop. Que | Eff. Stop Rate | Aver. No. of Cycles | Aver. Speed km/h |
|                              |      |           | [ Total HV ]<br>veh/h | %   | [ Total HV ]<br>veh/h | %   |           |             |                  | [ Veh. veh        | Dist ]<br>m |           |                |                     |                  |
| East: Raglan St (E)          |      |           |                       |     |                       |     |           |             |                  |                   |             |           |                |                     |                  |
| 5                            | T1   | All MCs   | 178                   | 5.3 | 178                   | 5.3 | 0.171     | 4.3         | LOS A            | 1.1               | 8.1         | 0.30      | 0.45           | 0.30                | 40.2             |
| 6                            | R2   | All MCs   | 25                    | 0.0 | 25                    | 0.0 | 0.171     | 7.3         | LOS A            | 1.1               | 8.1         | 0.30      | 0.45           | 0.30                | 42.0             |
| 6u                           | U    | All MCs   | 1                     | 0.0 | 1                     | 0.0 | 0.171     | 8.8         | LOS A            | 1.1               | 8.1         | 0.30      | 0.45           | 0.30                | 42.5             |
| Approach                     |      |           | 204                   | 4.6 | 204                   | 4.6 | 0.171     | 4.7         | LOS A            | 1.1               | 8.1         | 0.30      | 0.45           | 0.30                | 40.5             |
| North: Cope St (N)           |      |           |                       |     |                       |     |           |             |                  |                   |             |           |                |                     |                  |
| 7                            | L2   | All MCs   | 21                    | 0.0 | 21                    | 0.0 | 0.097     | 5.6         | LOS A            | 0.6               | 4.1         | 0.48      | 0.61           | 0.48                | 40.3             |
| 9                            | R2   | All MCs   | 71                    | 1.5 | 71                    | 1.5 | 0.097     | 8.6         | LOS A            | 0.6               | 4.1         | 0.48      | 0.61           | 0.48                | 35.4             |
| 9u                           | U    | All MCs   | 2                     | 0.0 | 2                     | 0.0 | 0.097     | 10.1        | LOS A            | 0.6               | 4.1         | 0.48      | 0.61           | 0.48                | 39.2             |
| Approach                     |      |           | 94                    | 1.1 | 94                    | 1.1 | 0.097     | 8.0         | LOS A            | 0.6               | 4.1         | 0.48      | 0.61           | 0.48                | 37.2             |
| West: Raglan St (W)          |      |           |                       |     |                       |     |           |             |                  |                   |             |           |                |                     |                  |
| 10                           | L2   | All MCs   | 56                    | 0.0 | 56                    | 0.0 | 0.231     | 3.9         | LOS A            | 1.4               | 10.2        | 0.15      | 0.43           | 0.15                | 39.8             |
| 11                           | T1   | All MCs   | 260                   | 2.8 | 260                   | 2.8 | 0.231     | 3.7         | LOS A            | 1.4               | 10.2        | 0.15      | 0.43           | 0.15                | 41.3             |
| 12u                          | U    | All MCs   | 11                    | 0.0 | 11                    | 0.0 | 0.231     | 8.4         | LOS A            | 1.4               | 10.2        | 0.15      | 0.43           | 0.15                | 28.9             |
| Approach                     |      |           | 326                   | 2.3 | 326                   | 2.3 | 0.231     | 3.9         | LOS A            | 1.4               | 10.2        | 0.15      | 0.43           | 0.15                | 40.9             |
| All Vehicles                 |      |           | 624                   | 2.9 | 624                   | 2.9 | 0.231     | 4.8         | LOS A            | 1.4               | 10.2        | 0.25      | 0.46           | 0.25                | 40.2             |

Site Level of Service (LOS) Method: Delay (RTA NSW). Site LOS Method is specified in the Network Data dialog (Override Site Data tab).

Vehicle movement LOS values are based on average delay per movement.

Intersection and Approach LOS values are based on average delay for all vehicle movements.

Roundabout Capacity Model: SIDRA Standard.

Delay Model: SIDRA Standard (Control Delay: Geometric Delay is included).

Queue Model: SIDRA queue estimation methods are used for Back of Queue and Queue at Start of Gap.

Gap-Acceptance Capacity Formula: SIDRA Standard (Akçelik M3D).

HV (%) values are calculated for All Movement Classes of All Heavy Vehicle Model Designation.

Arrival Flows used in performance calculations are adjusted to include any Initial Queued Demand and Upstream Capacity Constraint effects.

---

**SIDRA INTERSECTION 9.1 | Copyright © 2000-2022 Akcelik and Associates Pty Ltd | sidrasolutions.com**

Organisation: AECOM AUSTRALIA PTY LTD | Licence: NETWORK / Enterprise Level 1 | Processed: Thursday, 13 July 2023 12:12:16 PM

Project: C:\Users\Yeung\AECOM\ANZ-NAC-Sydney Metro-Sydney Metro C&SW Operational Monitoring - General\400\_Technical\432\_Traffic Analysis\SIDRA Modelling\01 Models (Geometry Only)\Block 1\Rev1\\_Review\08 SM C&SW\_WLO (Block 1)\_PS.sip9

# MOVEMENT SUMMARY

Site: WLO03 [WLO03 Botany Rd / Wellington St / Buckland St  
(Site Folder: Block 1 Model - 2023 Weekend Peak)]

Output produced by SIDRA INTERSECTION Version: 9.1.1.200

Network: WLO-N1 [WLO  
Network 1 (Network Folder:  
Block 1 Network - 2023  
Weekend Peak)]

TCS 137

Site Category: (None)

Signals - EQUISAT (Fixed-Time/SCATS) Coordinated Cycle Time = 120 seconds (Network Site User-Given Phase Times)

| Vehicle Movement Performance |      |           |                       |     |                       |     |           |             |                  |                   |               |           |                |                     |             |
|------------------------------|------|-----------|-----------------------|-----|-----------------------|-----|-----------|-------------|------------------|-------------------|---------------|-----------|----------------|---------------------|-------------|
| Mov ID                       | Turn | Mov Class | Demand Flows          |     | Arrival Flows         |     | Deg. Satn | Aver. Delay | Level of Service | 95% Back Of Queue |               | Prop. Que | Eff. Stop Rate | Aver. No. of Cycles | Aver. Speed |
|                              |      |           | [ Total HV ]<br>veh/h | %   | [ Total HV ]<br>veh/h | %   |           |             |                  | [ Veh. veh        | [ Dist ]<br>m |           |                |                     |             |
| South: Botany Rd (S)         |      |           |                       |     |                       |     |           |             |                  |                   |               |           |                |                     |             |
| 2                            | T1   | All MCs   | 418                   | 5.3 | 418                   | 5.3 | 0.402     | 6.1         | LOS A            | 8.9               | 64.5          | 0.40      | 0.39           | 0.40                | 37.6        |
| 3                            | R2   | All MCs   | 71                    | 0.0 | 71                    | 0.0 | 0.402     | 16.8        | LOS B            | 8.9               | 64.5          | 0.44      | 0.45           | 0.44                | 36.2        |
| Approach                     |      |           | 488                   | 4.5 | 488                   | 4.5 | 0.402     | 7.6         | LOS A            | 8.9               | 64.5          | 0.40      | 0.40           | 0.40                | 37.4        |
| East: Wellington St (E)      |      |           |                       |     |                       |     |           |             |                  |                   |               |           |                |                     |             |
| 4                            | L2   | All MCs   | 68                    | 0.0 | 68                    | 0.0 | 0.276     | 57.6        | LOS E            | 3.7               | 25.8          | 0.94      | 0.76           | 0.94                | 15.8        |
| 6                            | R2   | All MCs   | 36                    | 0.0 | 36                    | 0.0 | 0.207     | 58.7        | LOS E            | 2.0               | 13.8          | 0.95      | 0.73           | 0.95                | 4.1         |
| Approach                     |      |           | 104                   | 0.0 | 104                   | 0.0 | 0.276     | 58.0        | LOS E            | 3.7               | 25.8          | 0.94      | 0.75           | 0.94                | 12.5        |
| North: Botany Rd (N)         |      |           |                       |     |                       |     |           |             |                  |                   |               |           |                |                     |             |
| 7                            | L2   | All MCs   | 28                    | 0.0 | 28                    | 0.0 | 0.113     | 10.5        | LOS A            | 1.2               | 8.5           | 0.14      | 0.21           | 0.14                | 42.6        |
| 8                            | T1   | All MCs   | 760                   | 7.3 | 760                   | 7.3 | *0.563    | 6.6         | LOS A            | 8.6               | 63.7          | 0.24      | 0.23           | 0.24                | 46.5        |
| Approach                     |      |           | 788                   | 7.1 | 788                   | 7.1 | 0.563     | 6.7         | LOS A            | 8.6               | 63.7          | 0.23      | 0.23           | 0.23                | 46.5        |
| West: Buckland St (W)        |      |           |                       |     |                       |     |           |             |                  |                   |               |           |                |                     |             |
| 10                           | L2   | All MCs   | 22                    | 0.0 | 22                    | 0.0 | 0.313     | 54.4        | LOS D            | 4.6               | 33.2          | 0.93      | 0.74           | 0.93                | 5.3         |
| 11                           | T1   | All MCs   | 65                    | 3.2 | 65                    | 3.2 | *0.313    | 49.6        | LOS D            | 4.6               | 33.2          | 0.93      | 0.74           | 0.93                | 5.3         |
| 12                           | R2   | All MCs   | 22                    | 0.0 | 22                    | 0.0 | 0.115     | 54.9        | LOS D            | 1.2               | 8.2           | 0.92      | 0.71           | 0.92                | 15.8        |
| Approach                     |      |           | 109                   | 1.9 | 109                   | 1.9 | 0.313     | 51.7        | LOS D            | 4.6               | 33.2          | 0.93      | 0.73           | 0.93                | 8.1         |
| All Vehicles                 |      |           | 1491                  | 5.4 | 1491                  | 5.4 | 0.563     | 13.9        | LOS A            | 8.9               | 64.5          | 0.39      | 0.36           | 0.39                | 35.5        |

Site Level of Service (LOS) Method: Delay (RTA NSW). Site LOS Method is specified in the Network Data dialog (Override Site Data tab).

Vehicle movement LOS values are based on average delay per movement.

Intersection and Approach LOS values are based on average delay for all vehicle movements.

Delay Model: SIDRA Standard (Control Delay: Geometric Delay is included).

Queue Model: SIDRA queue estimation methods are used for Back of Queue and Queue at Start of Green.

Gap-Acceptance Capacity Formula: SIDRA Standard (Akçelik M3D).

HV (%) values are calculated for All Movement Classes of All Heavy Vehicle Model Designation.

Arrival Flows used in performance calculations are adjusted to include any Initial Queued Demand and Upstream Capacity Constraint effects.

\* Critical Movement (Signal Timing)

| Pedestrian Movement Performance |          |           |             |                  |                       |        |           |                |             |              |             |
|---------------------------------|----------|-----------|-------------|------------------|-----------------------|--------|-----------|----------------|-------------|--------------|-------------|
| Mov ID                          | Crossing | Dem. Flow | Aver. Delay | Level of Service | AVERAGE BACK OF QUEUE |        | Prop. Que | Eff. Stop Rate | Travel Time | Travel Dist. | Aver. Speed |
|                                 |          | ped/h     | sec         |                  | [ Ped                 | Dist ] |           |                | sec         | m            | m/sec       |
|                                 |          |           |             |                  | ped                   | m      |           |                |             |              |             |
| South: Botany Rd (S)            |          |           |             |                  |                       |        |           |                |             |              |             |
| P1                              | Full     | 41        | 48.7        | LOS E            | 0.1                   | 0.1    | 0.90      | 0.90           | 65.3        | 20.0         | 0.31        |
| East: Wellington St (E)         |          |           |             |                  |                       |        |           |                |             |              |             |
| P2                              | Full     | 51        | 48.7        | LOS E            | 0.2                   | 0.2    | 0.90      | 0.90           | 65.4        | 20.0         | 0.31        |
| North: Botany Rd (N)            |          |           |             |                  |                       |        |           |                |             |              |             |
| P3                              | Full     | 23        | 48.6        | LOS E            | 0.1                   | 0.1    | 0.90      | 0.90           | 65.3        | 20.0         | 0.31        |
| West: Buckland St (W)           |          |           |             |                  |                       |        |           |                |             |              |             |
| P4                              | Full     | 65        | 48.7        | LOS E            | 0.2                   | 0.2    | 0.90      | 0.90           | 65.4        | 20.0         | 0.31        |
| All Pedestrians                 |          | 180       | 48.7        | LOS E            | 0.2                   | 0.2    | 0.90      | 0.90           | 65.4        | 20.0         | 0.31        |

Level of Service (LOS) Method: SIDRA Pedestrian LOS Method (Based on Average Delay)

Pedestrian movement LOS values are based on average delay per pedestrian movement.

Intersection LOS value for Pedestrians is based on average delay for all pedestrian movements.

**SIDRA INTERSECTION 9.1 | Copyright © 2000-2022 Akcelik and Associates Pty Ltd | sidrasolutions.com**

Organisation: AECOM AUSTRALIA PTY LTD | Licence: NETWORK / Enterprise Level 1 | Processed: Thursday, 13 July 2023 12:12:16 PM  
 Project: C:\Users\YeungMA\AECOM\ANZ-NAC-Sydney Metro-Sydney Metro C&SW Operational Monitoring - General\400\_Technical\432\_Traffic Analysis\SIDRA Modelling\01 Models (Geometry Only)\Block 1\Rev1\_Review\08 SM C&SW\_WLO (Block 1)\_PS.sip9

# MOVEMENT SUMMARY

Site: WLO04 [WLO04 Cope St / Wellington St (Site Folder: Block 1 Model - 2023 Weekend Peak)]

Output produced by SIDRA INTERSECTION Version: 9.1.1.200

Network: WLO-N1 [WLO Network 1 (Network Folder: Block 1 Network - 2023 Weekend Peak)]

NA  
Site Category: (None)  
Roundabout

| Vehicle Movement Performance |      |           |                       |     |                       |     |           |             |                  |                   |             |           |                |                     |                  |
|------------------------------|------|-----------|-----------------------|-----|-----------------------|-----|-----------|-------------|------------------|-------------------|-------------|-----------|----------------|---------------------|------------------|
| Mov ID                       | Turn | Mov Class | Demand Flows          |     | Arrival Flows         |     | Deg. Satn | Aver. Delay | Level of Service | 95% Back Of Queue |             | Prop. Que | Eff. Stop Rate | Aver. No. of Cycles | Aver. Speed km/h |
|                              |      |           | [ Total HV ]<br>veh/h | %   | [ Total HV ]<br>veh/h | %   |           |             |                  | [ Veh. veh        | Dist ]<br>m |           |                |                     |                  |
| South: Cope St (S)           |      |           |                       |     |                       |     |           |             |                  |                   |             |           |                |                     |                  |
| 1                            | L2   | All MCs   | 21                    | 0.0 | 21                    | 0.0 | 0.026     | 4.5         | LOS A            | 0.1               | 1.0         | 0.26      | 0.52           | 0.26                | 33.4             |
| 3                            | R2   | All MCs   | 7                     | 0.0 | 7                     | 0.0 | 0.026     | 7.2         | LOS A            | 0.1               | 1.0         | 0.26      | 0.52           | 0.26                | 35.9             |
| 3u                           | U    | All MCs   | 1                     | 0.0 | 1                     | 0.0 | 0.026     | 8.6         | LOS A            | 0.1               | 1.0         | 0.26      | 0.52           | 0.26                | 36.7             |
| Approach                     |      |           | 29                    | 0.0 | 29                    | 0.0 | 0.026     | 5.3         | LOS A            | 0.1               | 1.0         | 0.26      | 0.52           | 0.26                | 34.4             |
| East: Wellington St (E)      |      |           |                       |     |                       |     |           |             |                  |                   |             |           |                |                     |                  |
| 4                            | L2   | All MCs   | 14                    | 0.0 | 14                    | 0.0 | 0.069     | 4.1         | LOS A            | 0.4               | 2.9         | 0.12      | 0.44           | 0.12                | 38.3             |
| 5                            | T1   | All MCs   | 77                    | 0.0 | 77                    | 0.0 | 0.069     | 3.9         | LOS A            | 0.4               | 2.9         | 0.12      | 0.44           | 0.12                | 34.6             |
| 6u                           | U    | All MCs   | 2                     | 0.0 | 2                     | 0.0 | 0.069     | 8.1         | LOS A            | 0.4               | 2.9         | 0.12      | 0.44           | 0.12                | 36.8             |
| Approach                     |      |           | 93                    | 0.0 | 93                    | 0.0 | 0.069     | 4.0         | LOS A            | 0.4               | 2.9         | 0.12      | 0.44           | 0.12                | 35.6             |
| West: Wellington St (W)      |      |           |                       |     |                       |     |           |             |                  |                   |             |           |                |                     |                  |
| 11                           | T1   | All MCs   | 145                   | 1.4 | 145                   | 1.4 | 0.113     | 3.5         | LOS A            | 0.6               | 4.0         | 0.06      | 0.46           | 0.06                | 35.9             |
| 12                           | R2   | All MCs   | 12                    | 0.0 | 12                    | 0.0 | 0.113     | 6.4         | LOS A            | 0.6               | 4.0         | 0.06      | 0.46           | 0.06                | 35.8             |
| 12u                          | U    | All MCs   | 9                     | 0.0 | 9                     | 0.0 | 0.113     | 7.8         | LOS A            | 0.6               | 4.0         | 0.06      | 0.46           | 0.06                | 28.8             |
| Approach                     |      |           | 166                   | 1.3 | 166                   | 1.3 | 0.113     | 3.9         | LOS A            | 0.6               | 4.0         | 0.06      | 0.46           | 0.06                | 35.7             |
| All Vehicles                 |      |           | 288                   | 0.7 | 288                   | 0.7 | 0.113     | 4.1         | LOS A            | 0.6               | 4.0         | 0.10      | 0.46           | 0.10                | 35.5             |

Site Level of Service (LOS) Method: Delay (RTA NSW). Site LOS Method is specified in the Network Data dialog (Override Site Data tab).

Vehicle movement LOS values are based on average delay per movement.

Intersection and Approach LOS values are based on average delay for all vehicle movements.

Roundabout Capacity Model: SIDRA Standard.

Delay Model: SIDRA Standard (Control Delay: Geometric Delay is included).

Queue Model: SIDRA queue estimation methods are used for Back of Queue and Queue at Start of Gap.

Gap-Acceptance Capacity Formula: SIDRA Standard (Akçelik M3D).

HV (%) values are calculated for All Movement Classes of All Heavy Vehicle Model Designation.

Arrival Flows used in performance calculations are adjusted to include any Initial Queued Demand and Upstream Capacity Constraint effects.

---

**SIDRA INTERSECTION 9.1 | Copyright © 2000-2022 Akcelik and Associates Pty Ltd | sidrasolutions.com**

Organisation: AECOM AUSTRALIA PTY LTD | Licence: NETWORK / Enterprise Level 1 | Processed: Thursday, 13 July 2023 12:12:16 PM

Project: C:\Users\Yeung\AECOMANZ-NAC-Sydney Metro-Sydney Metro C&SW Operational Monitoring - General\400\_Technical\432\_Traffic Analysis\SIDRA Modelling\01 Models (Geometry Only)\Block 1\Rev1\\_Review\08 SM C&SW\_WLO (Block 1)\_PS.sip9

# MOVEMENT SUMMARY

Site: WLO05 [WLO05 Wyndham St / Henderson Rd (Site Folder: Block 1 Model - 2023 Weekend Peak)]

Output produced by SIDRA INTERSECTION Version: 9.1.1.200

Network: WLO-N1 [WLO Network 1 (Network Folder: Block 1 Network - 2023 Weekend Peak)]

TCS 55

Site Category: (None)

Signals - EQUISAT (Fixed-Time/SCATS) Coordinated Cycle Time = 120 seconds (Network Site User-Given Phase Times)

| Vehicle Movement Performance |      |           |              |     |               |     |           |             |                  |                   |          |           |                |                     |             |
|------------------------------|------|-----------|--------------|-----|---------------|-----|-----------|-------------|------------------|-------------------|----------|-----------|----------------|---------------------|-------------|
| Mov ID                       | Turn | Mov Class | Demand Flows |     | Arrival Flows |     | Deg. Satn | Aver. Delay | Level of Service | 95% Back Of Queue |          | Prop. Que | Eff. Stop Rate | Aver. No. of Cycles | Aver. Speed |
|                              |      |           | [ Total HV ] | %   | [ Total HV ]  | %   |           |             |                  | [ Veh. veh        | Dist ] m |           |                |                     |             |
| South: Wyndham St (S)        |      |           |              |     |               |     |           |             |                  |                   |          |           |                |                     |             |
| 1                            | L2   | All MCs   | 22           | 0.0 | 22            | 0.0 | * 0.726   | 67.7        | LOS E            | 12.9              | 91.8     | 0.98      | 0.87           | 1.05                | 12.0        |
| 2                            | T1   | All MCs   | 427          | 2.2 | 427           | 2.2 | 0.726     | 61.2        | LOS E            | 12.9              | 91.8     | 0.98      | 0.87           | 1.05                | 19.2        |
| 3                            | R2   | All MCs   | 540          | 0.0 | 540           | 0.0 | 0.726     | 67.2        | LOS E            | 12.8              | 92.2     | 0.98      | 0.87           | 1.05                | 12.7        |
| Approach                     |      |           | 455          | 2.5 | 455           | 2.5 | 0.726     | 61.6        | LOS E            | 12.9              | 92.2     | 0.98      | 0.87           | 1.05                | 18.7        |
| East: Henderson Rd (E)       |      |           |              |     |               |     |           |             |                  |                   |          |           |                |                     |             |
| 4                            | L2   | All MCs   | 239          | 0.9 | 239           | 0.9 | 0.350     | 12.4        | LOS A            | 10.1              | 71.4     | 0.42      | 0.54           | 0.42                | 31.8        |
| 5                            | T1   | All MCs   | 662          | 2.4 | 662           | 2.4 | 0.350     | 7.5         | LOS A            | 10.1              | 71.4     | 0.42      | 0.42           | 0.42                | 27.1        |
| 6                            | R2   | All MCs   | 507          | 5.2 | 507           | 5.2 | * 0.412   | 19.2        | LOS B            | 5.4               | 39.7     | 0.71      | 0.76           | 0.71                | 23.9        |
| Approach                     |      |           | 1408         | 3.1 | 1408          | 3.1 | 0.412     | 12.5        | LOS A            | 10.1              | 71.7     | 0.52      | 0.57           | 0.52                | 26.4        |
| West: Henderson Rd (W)       |      |           |              |     |               |     |           |             |                  |                   |          |           |                |                     |             |
| 10                           | L2   | All MCs   | 398          | 2.4 | 398           | 2.4 | * 0.885   | 92.0        | LOS F            | 20.6              | 147.0    | 0.97      | 0.94           | 1.17                | 11.7        |
| 11                           | T1   | All MCs   | 278          | 0.8 | 278           | 0.8 | 0.574     | 42.6        | LOS D            | 14.3              | 100.9    | 0.93      | 0.79           | 0.93                | 5.4         |
| Approach                     |      |           | 676          | 1.7 | 676           | 1.7 | 0.885     | 71.7        | LOS F            | 20.6              | 147.0    | 0.95      | 0.88           | 1.07                | 9.9         |
| All Vehicles                 |      |           | 2539         | 2.7 | 2539          | 2.7 | 0.885     | 37.1        | LOS C            | 20.6              | 147.0    | 0.72      | 0.70           | 0.76                | 18.0        |

Site Level of Service (LOS) Method: Delay (RTA NSW). Site LOS Method is specified in the Network Data dialog (Override Site Data tab).

Vehicle movement LOS values are based on average delay per movement.

Intersection and Approach LOS values are based on average delay for all vehicle movements.

Delay Model: SIDRA Standard (Control Delay: Geometric Delay is included).

Queue Model: SIDRA queue estimation methods are used for Back of Queue and Queue at Start of Green.

Gap-Acceptance Capacity Formula: SIDRA Standard (Akçelik M3D).

HV (%) values are calculated for All Movement Classes of All Heavy Vehicle Model Designation.

Arrival Flows used in performance calculations are adjusted to include any Initial Queued Demand and Upstream Capacity Constraint effects.

\* Critical Movement (Signal Timing)



| Pedestrian Movement Performance |          |           |             |                  |                       |        |           |                |             |              |             |
|---------------------------------|----------|-----------|-------------|------------------|-----------------------|--------|-----------|----------------|-------------|--------------|-------------|
| Mov ID                          | Crossing | Dem. Flow | Aver. Delay | Level of Service | AVERAGE BACK OF QUEUE |        | Prop. Que | Eff. Stop Rate | Travel Time | Travel Dist. | Aver. Speed |
|                                 |          | ped/h     | sec         |                  | [ Ped                 | Dist ] |           |                | sec         | m            | m/sec       |
|                                 |          |           |             |                  | ped                   | m      |           |                |             |              |             |
| South: Wyndham St (S)           |          |           |             |                  |                       |        |           |                |             |              |             |
| P1                              | Full     | 23        | 49.6        | LOS E            | 0.1                   | 0.1    | 0.91      | 0.91           | 66.2        | 20.0         | 0.30        |
| East: Henderson Rd (E)          |          |           |             |                  |                       |        |           |                |             |              |             |
| P2                              | Full     | 28        | 47.8        | LOS E            | 0.1                   | 0.1    | 0.89      | 0.89           | 64.4        | 20.0         | 0.31        |
| North: Wyndham St (N)           |          |           |             |                  |                       |        |           |                |             |              |             |
| P3                              | Full     | 28        | 49.6        | LOS E            | 0.1                   | 0.1    | 0.91      | 0.91           | 66.2        | 20.0         | 0.30        |
| West: Henderson Rd (W)          |          |           |             |                  |                       |        |           |                |             |              |             |
| P4                              | Full     | 28        | 47.8        | LOS E            | 0.1                   | 0.1    | 0.89      | 0.89           | 64.4        | 20.0         | 0.31        |
| All Pedestrians                 |          | 108       | 48.6        | LOS E            | 0.1                   | 0.1    | 0.90      | 0.90           | 65.3        | 20.0         | 0.31        |

Level of Service (LOS) Method: SIDRA Pedestrian LOS Method (Based on Average Delay)

Pedestrian movement LOS values are based on average delay per pedestrian movement.

Intersection LOS value for Pedestrians is based on average delay for all pedestrian movements.

**SIDRA INTERSECTION 9.1 | Copyright © 2000-2022 Akcelik and Associates Pty Ltd | sidrasolutions.com**

Organisation: AECOM AUSTRALIA PTY LTD | Licence: NETWORK / Enterprise Level 1 | Processed: Thursday, 13 July 2023 12:12:16 PM

Project: C:\Users\YeungMAECOMANZ-NAC-Sydney Metro-Sydney Metro C&SW Operational Monitoring - General\400\_Technical\432\_Traffic

Analysis\SIDRA Modelling\01 Models (Geometry Only)\Block 1\Rev1\_Review\08 SM C&SW\_WLO (Block 1)\_PS.sip9

# MOVEMENT SUMMARY

Site: SYD01 [SYD01 Railway Pde / Gleeson Ave (Site Folder: Block 1 Model - 2023 AM Peak)]

Output produced by SIDRA INTERSECTION Version: 9.1.1.200

Network: SYD-N1 [SYD Network 1 (Network Folder: Block 1 Network - 2023 AM Peak)]

TCS 3320

Site Category: (None)

Signals - EQUISAT (Fixed-Time/SCATS) Isolated Cycle Time = 90 seconds (Site User-Given Phase Times)

| Vehicle Movement Performance |      |           |                       |      |                       |      |           |             |                  |                   |               |           |                |                     |                  |
|------------------------------|------|-----------|-----------------------|------|-----------------------|------|-----------|-------------|------------------|-------------------|---------------|-----------|----------------|---------------------|------------------|
| Mov ID                       | Turn | Mov Class | Demand Flows          |      | Arrival Flows         |      | Deg. Satn | Aver. Delay | Level of Service | 95% Back Of Queue |               | Prop. Que | Eff. Stop Rate | Aver. No. of Cycles | Aver. Speed km/h |
|                              |      |           | [ Total HV ]<br>veh/h | %    | [ Total HV ]<br>veh/h | %    |           |             |                  | [ Veh. veh        | [ Dist ]<br>m |           |                |                     |                  |
| SouthEast: Gleeson Ave (SE)  |      |           |                       |      |                       |      |           |             |                  |                   |               |           |                |                     |                  |
| 1                            | L2   | All MCs   | 867                   | 7.5  | 867                   | 7.5  | 0.381     | 4.8         | LOS A            | 0.0               | 0.0           | 0.00      | 0.51           | 0.00                | 42.2             |
| Approach                     |      |           | 867                   | 7.5  | 867                   | 7.5  | 0.381     | 4.8         | LOS A            | 0.0               | 0.0           | 0.00      | 0.51           | 0.00                | 42.2             |
| NorthEast: Railway Pde (NE)  |      |           |                       |      |                       |      |           |             |                  |                   |               |           |                |                     |                  |
| 4                            | L2   | All MCs   | 1104                  | 6.3  | 1104                  | 6.3  | * 0.529   | 11.8        | LOS A            | 10.6              | 78.2          | 0.44      | 0.69           | 0.44                | 33.7             |
| 5                            | T1   | All MCs   | 61                    | 22.4 | 61                    | 22.4 | * 0.051   | 10.7        | LOS A            | 0.4               | 3.3           | 0.27      | 0.21           | 0.27                | 56.3             |
| Approach                     |      |           | 1165                  | 7.1  | 1165                  | 7.1  | 0.529     | 11.7        | LOS A            | 10.6              | 78.2          | 0.43      | 0.67           | 0.43                | 34.9             |
| All Vehicles                 |      |           | 2033                  | 7.3  | 2033                  | 7.3  | 0.529     | 8.8         | LOS A            | 10.6              | 78.2          | 0.25      | 0.60           | 0.25                | 38.0             |

Site Level of Service (LOS) Method: Delay (RTA NSW). Site LOS Method is specified in the Network Data dialog (Override Site Data tab).

Vehicle movement LOS values are based on average delay per movement.

Intersection and Approach LOS values are based on average delay for all vehicle movements.

Delay Model: SIDRA Standard (Control Delay: Geometric Delay is included).

Queue Model: SIDRA queue estimation methods are used for Back of Queue and Queue at Start of Green.

Gap-Acceptance Capacity Formula: SIDRA Standard (Akçelik M3D).

HV (%) values are calculated for All Movement Classes of All Heavy Vehicle Model Designation.

Arrival Flows used in performance calculations are adjusted to include any Initial Queued Demand and Upstream Capacity Constraint effects.

\* Critical Movement (Signal Timing)

| Pedestrian Movement Performance |                 |           |             |                  |                       |        |           |                |             |              |             |
|---------------------------------|-----------------|-----------|-------------|------------------|-----------------------|--------|-----------|----------------|-------------|--------------|-------------|
| Mov ID                          | Crossing        | Dem. Flow | Aver. Delay | Level of Service | AVERAGE BACK OF QUEUE |        | Prop. Que | Eff. Stop Rate | Travel Time | Travel Dist. | Aver. Speed |
|                                 |                 | ped/h     | sec         |                  | [ Ped                 | Dist ] |           |                | sec         | m            | m/sec       |
|                                 |                 |           |             |                  | ped                   | m      |           |                |             |              |             |
| NorthEast: Railway Pde (NE)     |                 |           |             |                  |                       |        |           |                |             |              |             |
| P2                              | Full            | 218       | 22.4        | LOS C            | 0.4                   | 0.4    | 0.83      | 0.83           | 39.0        | 20.0         | 0.51        |
| P2S                             | Slip/<br>Bypass | 218       | 37.7        | LOS D            | 0.5                   | 0.5    | 0.92      | 0.92           | 54.4        | 20.0         | 0.37        |
| All Pedestrians                 |                 | 436       | 30.0        | LOS D            | 0.5                   | 0.5    | 0.87      | 0.87           | 46.7        | 20.0         | 0.43        |

Level of Service (LOS) Method: SIDRA Pedestrian LOS Method (Based on Average Delay)

Pedestrian movement LOS values are based on average delay per pedestrian movement.

Intersection LOS value for Pedestrians is based on average delay for all pedestrian movements.

---

**SIDRA INTERSECTION 9.1 | Copyright © 2000-2022 Akcelik and Associates Pty Ltd | sidrasolutions.com**

Organisation: AECOM AUSTRALIA PTY LTD | Licence: NETWORK / Enterprise Level 1 | Processed: Monday, 17 July 2023 10:14:01 AM

Project: C:\Users\YeungM\AECOM\ANZ-NAC-Sydney Metro-Sydney Metro C&SW Operational Monitoring - General\400\_Technical\432\_Traffic Analysis\SIDRA Modelling\01 Models (Geometry Only)\Block 1\Rev1\Review\09 SM C&SW\_SYD (Block 1)\_SH.sip9

# MOVEMENT SUMMARY

Site: SYD02 [SYD02 Burrows Ave / Gleeson Ave (Site Folder: Block 1 Model - 2023 AM Peak)]

Output produced by SIDRA INTERSECTION Version: 9.1.1.200

Network: SYD-N1 [SYD Network 1 (Network Folder: Block 1 Network - 2023 AM Peak)]

TCS 1152

Site Category: (None)

Signals - EQUISAT (Fixed-Time/SCATS) Coordinated Cycle Time = 110 seconds (Site User-Given Phase Times)

| Vehicle Movement Performance |      |           |              |              |               |              |           |             |                  |                   |            |           |                |                     |             |
|------------------------------|------|-----------|--------------|--------------|---------------|--------------|-----------|-------------|------------------|-------------------|------------|-----------|----------------|---------------------|-------------|
| Mov ID                       | Turn | Mov Class | Demand Flows |              | Arrival Flows |              | Deg. Satn | Aver. Delay | Level of Service | 95% Back Of Queue |            | Prop. Que | Eff. Stop Rate | Aver. No. of Cycles | Aver. Speed |
|                              |      |           | [ Total HV ] | [ Total HV ] | [ Total HV ]  | [ Total HV ] |           |             |                  | [ Veh. veh        | [ Dist ] m |           |                |                     |             |
|                              |      |           | veh/h        | %            | veh/h         | %            | v/c       | sec         |                  |                   |            |           |                |                     | km/h        |
| SouthEast: Gleeson Ave (SE)  |      |           |              |              |               |              |           |             |                  |                   |            |           |                |                     |             |
| 2                            | T1   | All MCs   | 619          | 8.8          | 619           | 8.8          | 0.311     | 14.0        | LOS A            | 8.8               | 66.4       | 0.58      | 0.50           | 0.58                | 22.1        |
| Approach                     |      |           | 619          | 8.8          | 619           | 8.8          | 0.311     | 14.0        | LOS A            | 8.8               | 66.4       | 0.58      | 0.50           | 0.58                | 22.1        |
| NorthEast: Burrows Ave (NE)  |      |           |              |              |               |              |           |             |                  |                   |            |           |                |                     |             |
| 4                            | L2   | All MCs   | 36           | 26.5         | 36            | 26.5         | 0.195     | 58.4        | LOS E            | 1.8               | 15.3       | 0.93      | 0.73           | 0.93                | 13.9        |
| 6                            | R2   | All MCs   | 232          | 2.3          | 232           | 2.3          | *0.514    | 57.3        | LOS E            | 6.2               | 44.0       | 0.98      | 0.79           | 0.98                | 9.3         |
| Approach                     |      |           | 267          | 5.5          | 267           | 5.5          | 0.514     | 57.5        | LOS E            | 6.2               | 44.0       | 0.97      | 0.78           | 0.97                | 10.0        |
| NorthWest: Gleeson Ave (NW)  |      |           |              |              |               |              |           |             |                  |                   |            |           |                |                     |             |
| 7                            | L2   | All MCs   | 232          | 6.4          | 232           | 6.4          | 0.564     | 7.5         | LOS A            | 8.2               | 60.8       | 0.31      | 0.45           | 0.31                | 33.9        |
| 8                            | T1   | All MCs   | 873          | 6.3          | 873           | 6.3          | *0.564    | 5.4         | LOS A            | 8.9               | 65.9       | 0.32      | 0.34           | 0.32                | 40.5        |
| Approach                     |      |           | 1104         | 6.3          | 1104          | 6.3          | 0.564     | 5.8         | LOS A            | 8.9               | 65.9       | 0.32      | 0.37           | 0.32                | 38.7        |
| SouthWest: Burrows Ave (SW)  |      |           |              |              |               |              |           |             |                  |                   |            |           |                |                     |             |
| 10                           | L2   | All MCs   | 17           | 31.3         | 17            | 31.3         | 0.091     | 59.4        | LOS E            | 0.6               | 5.0        | 0.95      | 0.67           | 0.95                | 10.6        |
| 11                           | T1   | All MCs   | 4            | 0.0          | 4             | 0.0          | 0.091     | 44.9        | LOS D            | 0.6               | 5.0        | 0.94      | 0.67           | 0.94                | 16.5        |
| 12                           | R2   | All MCs   | 6            | 50.0         | 6             | 50.0         | 0.032     | 47.4        | LOS D            | 0.3               | 2.9        | 0.87      | 0.66           | 0.87                | 16.0        |
| Approach                     |      |           | 27           | 30.8         | 27            | 30.8         | 0.091     | 54.4        | LOS D            | 0.6               | 5.0        | 0.93      | 0.67           | 0.93                | 12.8        |
| All Vehicles                 |      |           | 2018         | 7.3          | 2018          | 7.3          | 0.564     | 15.8        | LOS B            | 8.9               | 66.4       | 0.49      | 0.47           | 0.49                | 24.0        |

Site Level of Service (LOS) Method: Delay (RTA NSW). Site LOS Method is specified in the Network Data dialog (Override Site Data tab).

Vehicle movement LOS values are based on average delay per movement.

Intersection and Approach LOS values are based on average delay for all vehicle movements.

Delay Model: SIDRA Standard (Control Delay: Geometric Delay is included).

Queue Model: SIDRA queue estimation methods are used for Back of Queue and Queue at Start of Green.

Gap-Acceptance Capacity Formula: SIDRA Standard (Akçelik M3D).

HV (%) values are calculated for All Movement Classes of All Heavy Vehicle Model Designation.

Arrival Flows used in performance calculations are adjusted to include any Initial Queued Demand and Upstream Capacity Constraint effects.

\* Critical Movement (Signal Timing)

| Pedestrian Movement Performance |          |           |             |                  |                       |        |           |                |             |              |             |
|---------------------------------|----------|-----------|-------------|------------------|-----------------------|--------|-----------|----------------|-------------|--------------|-------------|
| Mov ID                          | Crossing | Dem. Flow | Aver. Delay | Level of Service | AVERAGE BACK OF QUEUE |        | Prop. Que | Eff. Stop Rate | Travel Time | Travel Dist. | Aver. Speed |
|                                 |          | ped/h     | sec         |                  | [ Ped                 | Dist ] |           |                | sec         | m            | m/sec       |
|                                 |          |           |             |                  | ped                   | m      |           |                |             |              |             |
| SouthEast: Gleeson Ave (SE)     |          |           |             |                  |                       |        |           |                |             |              |             |
| P1                              | Full     | 7         | 42.8        | LOS E            | 0.0                   | 0.0    | 0.88      | 0.88           | 59.4        | 20.0         | 0.34        |
| NorthEast: Burrows Ave (NE)     |          |           |             |                  |                       |        |           |                |             |              |             |
| P2                              | Full     | 136       | 43.0        | LOS E            | 0.4                   | 0.4    | 0.89      | 0.89           | 59.7        | 20.0         | 0.34        |
| NorthWest: Gleeson Ave (NW)     |          |           |             |                  |                       |        |           |                |             |              |             |
| P3                              | Full     | 304       | 40.7        | LOS E            | 0.8                   | 0.8    | 0.87      | 0.87           | 57.3        | 20.0         | 0.35        |
| SouthWest: Burrows Ave (SW)     |          |           |             |                  |                       |        |           |                |             |              |             |
| P4                              | Full     | 197       | 44.9        | LOS E            | 0.6                   | 0.6    | 0.91      | 0.91           | 61.6        | 20.0         | 0.32        |
| All Pedestrians                 |          | 644       | 42.5        | LOS E            | 0.8                   | 0.8    | 0.88      | 0.88           | 59.2        | 20.0         | 0.34        |

Level of Service (LOS) Method: SIDRA Pedestrian LOS Method (Based on Average Delay)

Pedestrian movement LOS values are based on average delay per pedestrian movement.

Intersection LOS value for Pedestrians is based on average delay for all pedestrian movements.

**SIDRA INTERSECTION 9.1 | Copyright © 2000-2022 Akcelik and Associates Pty Ltd | sidrasolutions.com**

Organisation: AECOM AUSTRALIA PTY LTD | Licence: NETWORK / Enterprise Level 1 | Processed: Monday, 17 July 2023 10:14:01 AM

Project: C:\Users\YeungMAECOMANZ-NAC-Sydney Metro-Sydney Metro C&SW Operational Monitoring - General\400\_Technical\432\_Traffic Analysis\SIDRA Modelling\01 Models (Geometry Only)\Block 1\Rev1\_Review\09 SM C&SW\_SYD (Block 1)\_SH.sip9

# MOVEMENT SUMMARY

Site: SYD03 [SYD03 Burrows Ave / George St (Site Folder: Block 1 Model - 2023 AM Peak)]

Output produced by SIDRA INTERSECTION Version: 9.1.1.200

NA

Site Category: (None)

Give-Way (Two-Way)

| Vehicle Movement Performance |      |           |              |      |               |      |           |             |                  |                   |          |           |                |                     |             |
|------------------------------|------|-----------|--------------|------|---------------|------|-----------|-------------|------------------|-------------------|----------|-----------|----------------|---------------------|-------------|
| Mov ID                       | Turn | Mov Class | Demand Flows |      | Arrival Flows |      | Deg. Satn | Aver. Delay | Level of Service | 95% Back Of Queue |          | Prop. Que | Eff. Stop Rate | Aver. No. of Cycles | Aver. Speed |
|                              |      |           | [ Total HV ] | %    | [ Total HV ]  | %    | v/c       | sec         |                  | [ Veh. ]          | [ Dist ] |           |                |                     | km/h        |
|                              |      |           | veh/h        |      | veh/h         |      |           |             |                  | veh               | m        |           |                |                     |             |
| SouthEast: George St (SE)    |      |           |              |      |               |      |           |             |                  |                   |          |           |                |                     |             |
| 4                            | L2   | All MCs   | 18           | 0.0  | 18            | 0.0  | 0.022     | 8.2         | LOSA             | 0.1               | 0.5      | 0.27      | 0.88           | 0.27                | 30.6        |
| 6                            | R2   | All MCs   | 4            | 0.0  | 4             | 0.0  | 0.022     | 9.8         | LOSA             | 0.1               | 0.5      | 0.27      | 0.88           | 0.27                | 26.6        |
| Approach                     |      |           | 22           | 0.0  | 22            | 0.0  | 0.022     | 8.5         | LOSA             | 0.1               | 0.5      | 0.27      | 0.88           | 0.27                | 29.9        |
| NorthEast: Burrows Ave (NE)  |      |           |              |      |               |      |           |             |                  |                   |          |           |                |                     |             |
| 7                            | L2   | All MCs   | 4            | 0.0  | 4             | 0.0  | 0.206     | 4.2         | LOSA             | 1.1               | 8.1      | 0.32      | 0.18           | 0.32                | 39.5        |
| 8                            | T1   | All MCs   | 199          | 9.0  | 199           | 9.0  | 0.206     | 1.0         | LOSA             | 1.1               | 8.1      | 0.32      | 0.18           | 0.32                | 45.5        |
| Approach                     |      |           | 203          | 8.8  | 203           | 8.8  | 0.206     | 1.1         | NA               | 1.1               | 8.1      | 0.32      | 0.18           | 0.32                | 45.3        |
| SouthWest: Burrows Ave (SW)  |      |           |              |      |               |      |           |             |                  |                   |          |           |                |                     |             |
| 2                            | T1   | All MCs   | 208          | 5.6  | 208           | 5.6  | 0.225     | 1.0         | LOSA             | 1.0               | 7.7      | 0.26      | 0.18           | 0.26                | 44.7        |
| 3                            | R2   | All MCs   | 19           | 50.0 | 19            | 50.0 | 0.225     | 6.4         | LOSA             | 1.0               | 7.7      | 0.26      | 0.18           | 0.26                | 35.5        |
| Approach                     |      |           | 227          | 9.3  | 227           | 9.3  | 0.225     | 1.5         | NA               | 1.0               | 7.7      | 0.26      | 0.18           | 0.26                | 43.5        |
| All Vehicles                 |      |           | 453          | 8.6  | 453           | 8.6  | 0.225     | 1.6         | NA               | 1.1               | 8.1      | 0.29      | 0.22           | 0.29                | 43.0        |

Site Level of Service (LOS) Method: Delay (RTA NSW). Site LOS Method is specified in the Parameter Settings dialog (Options tab).

Vehicle movement LOS values are based on average delay per movement.

Minor Road Approach LOS values are based on average delay for all vehicle movements.

NA (TWSC): Level of Service is not defined for major road approaches or the intersection as a whole for Two-Way Sign Control (HCM LOS rule).

Two-Way Sign Control Capacity Model: SIDRA Standard.

Delay Model: SIDRA Standard (Control Delay: Geometric Delay is included).

Queue Model: SIDRA queue estimation methods are used for Back of Queue and Queue at Start of Gap.

Gap-Acceptance Capacity Formula: SIDRA Standard (Akçelik M3D).

HV (%) values are calculated for All Movement Classes of All Heavy Vehicle Model Designation.

Arrival Flows used in performance calculations are adjusted to include any Initial Queued Demand and Upstream Capacity Constraint effects.

---

**SIDRA INTERSECTION 9.1 | Copyright © 2000-2022 Akcelik and Associates Pty Ltd | sidrasolutions.com**

Organisation: AECOM AUSTRALIA PTY LTD | Licence: NETWORK / Enterprise Level 1 | Processed: Friday, 14 July 2023 5:33:25 PM

Project: C:\Users\Yeung\AECOM\ANZ-NAC-Sydney Metro-Sydney Metro C&SW Operational Monitoring - General\400\_Technical\432\_Traffic Analysis\SIDRA Modelling\01 Models (Geometry Only)\Block 1\Rev1\\_Review\09 SM C&SW\_SYD (Block 1)\_SH.sip9

# MOVEMENT SUMMARY

 Site: SYD04 [SYD04 Pedestrian Mid-block Crossing at Sydenham Rd (Site Folder: Block 1 Model - 2023 AM Peak)]

Output produced by SIDRA INTERSECTION Version: 9.1.1.200

TCS 4946

Site Category: (None)

Pedestrian Crossing (Signalised) - EQUISAT (Fixed-Time/SCATS) Isolated Cycle Time = 100 seconds (Site User-Given Phase Times)

| Vehicle Movement Performance |      |           |                       |     |                       |     |           |             |                  |                   |               |           |                |                     |             |
|------------------------------|------|-----------|-----------------------|-----|-----------------------|-----|-----------|-------------|------------------|-------------------|---------------|-----------|----------------|---------------------|-------------|
| Mov ID                       | Turn | Mov Class | Demand Flows          |     | Arrival Flows         |     | Deg. Satn | Aver. Delay | Level of Service | 95% Back Of Queue |               | Prop. Que | Eff. Stop Rate | Aver. No. of Cycles | Aver. Speed |
|                              |      |           | [ Total HV ]<br>veh/h | %   | [ Total HV ]<br>veh/h | %   |           |             |                  | [ Veh. ]<br>veh   | [ Dist ]<br>m |           |                |                     |             |
| NorthWest: Sydenham Rd (NW)  |      |           |                       |     |                       |     |           |             |                  |                   |               |           |                |                     |             |
| 8                            | T1   | All MCs   | 1115                  | 9.0 | 1115                  | 9.0 | * 0.445   | 5.9         | LOSA             | 8.1               | 60.7          | 0.47      | 0.45           | 0.47                | 45.6        |
| Approach                     |      |           | 1115                  | 9.0 | 1115                  | 9.0 | 0.445     | 5.9         | LOSA             | 8.1               | 60.7          | 0.47      | 0.45           | 0.47                | 45.6        |
| All Vehicles                 |      |           | 1115                  | 9.0 | 1115                  | 9.0 | 0.445     | 5.9         | LOSA             | 8.1               | 60.7          | 0.47      | 0.45           | 0.47                | 45.6        |

Site Level of Service (LOS) Method: Delay (RTA NSW). Site LOS Method is specified in the Parameter Settings dialog (Options tab).

Vehicle movement LOS values are based on average delay per movement.

Intersection and Approach LOS values are based on average delay for all vehicle movements.

Delay Model: SIDRA Standard (Control Delay: Geometric Delay is included).

Queue Model: SIDRA queue estimation methods are used for Back of Queue and Queue at Start of Green.

Gap-Acceptance Capacity Formula: SIDRA Standard (Akçelik M3D).

HV (%) values are calculated for All Movement Classes of All Heavy Vehicle Model Designation.

Arrival Flows used in performance calculations are adjusted to include any Initial Queued Demand and Upstream Capacity Constraint effects.

\* Critical Movement (Signal Timing)



| Pedestrian Movement Performance |          |            |           |             |                  |                       |        |           |                |             |              |             |
|---------------------------------|----------|------------|-----------|-------------|------------------|-----------------------|--------|-----------|----------------|-------------|--------------|-------------|
| Mov ID                          | Crossing | Input Vol. | Dem. Flow | Aver. Delay | Level of Service | AVERAGE BACK OF QUEUE |        | Prop. Que | Eff. Stop Rate | Travel Time | Travel Dist. | Aver. Speed |
|                                 |          | ped/h      | ped/h     | sec         |                  | [ Ped                 | Dist ] |           |                | sec         | m            | m/sec       |
|                                 |          |            |           |             |                  | ped                   | m      |           |                |             |              |             |
| SouthEast: Sydenham Rd (SE)     |          |            |           |             |                  |                       |        |           |                |             |              |             |
| P1                              | Full     | 29         | 31        | 29.1        | LOS C            | 0.1                   | 0.1    | 0.82      | 0.82           | 195.8       | 200.0        | 1.02        |
| All                             |          | 29         | 31        | 29.1        | LOS C            | 0.1                   | 0.1    | 0.82      | 0.82           | 195.8       | 200.0        | 1.02        |
| Pedestrians                     |          |            |           |             |                  |                       |        |           |                |             |              |             |

Level of Service (LOS) Method: SIDRA Pedestrian LOS Method (Based on Average Delay)

Pedestrian movement LOS values are based on average delay per pedestrian movement.

Intersection LOS value for Pedestrians is based on average delay for all pedestrian movements.

**SIDRA INTERSECTION 9.1 | Copyright © 2000-2022 Akcelik and Associates Pty Ltd | sidrasolutions.com**

Organisation: AECOM AUSTRALIA PTY LTD | Licence: NETWORK / Enterprise Level 1 | Processed: Thursday, 13 July 2023 11:44:58 AM

Project: C:\Users\YeungMA\AECOM\ANZ-NAC-Sydney Metro-Sydney Metro C&SW Operational Monitoring - General\400\_Technical\432\_Traffic Analysis\SIDRA Modelling\01 Models (Geometry Only)\Block 1\Rev1\Review\09 SM C&SW\_SYD (Block 1)\_SH.sip9

# MOVEMENT SUMMARY

Site: SYD05 [SYD05 Marrickville Rd / Buckley St (Site Folder: Block 1 Model - 2023 AM Peak)]

Output produced by SIDRA INTERSECTION Version: 9.1.1.200

NA

Site Category: (None)

Give-Way (Two-Way)

| Vehicle Movement Performance    |      |           |              |      |               |      |           |             |                  |                   |            |           |                |                     |             |
|---------------------------------|------|-----------|--------------|------|---------------|------|-----------|-------------|------------------|-------------------|------------|-----------|----------------|---------------------|-------------|
| Mov ID                          | Turn | Mov Class | Demand Flows |      | Arrival Flows |      | Deg. Satn | Aver. Delay | Level of Service | 95% Back Of Queue |            | Prop. Que | Eff. Stop Rate | Aver. No. of Cycles | Aver. Speed |
|                                 |      |           | [ Total HV ] | %    | [ Total HV ]  | %    | v/c       | sec         |                  | [ Veh. veh        | [ Dist ] m |           |                |                     | km/h        |
| SouthEast: Marrickville Rd (SE) |      |           |              |      |               |      |           |             |                  |                   |            |           |                |                     |             |
| 2                               | T1   | All MCs   | 448          | 16.4 | 448           | 16.4 | 0.268     | 0.0         | LOS A            | 0.0               | 0.0        | 0.00      | 0.00           | 0.00                | 59.8        |
| 3                               | R2   | All MCs   | 573          | 9.0  | 573           | 9.0  | 0.747     | 8.1         | LOS A            | 5.9               | 44.1       | 0.50      | 0.63           | 0.60                | 42.8        |
| Approach                        |      |           | 1021         | 12.3 | 1021          | 12.3 | 0.747     | 4.5         | NA               | 5.9               | 44.1       | 0.28      | 0.35           | 0.34                | 49.8        |
| NorthWest: Marrickville Rd (NW) |      |           |              |      |               |      |           |             |                  |                   |            |           |                |                     |             |
| 7                               | L2   | All MCs   | 444          | 7.8  | 444           | 7.8  | 0.727     | 8.2         | LOS A            | 4.8               | 36.0       | 0.54      | 0.64           | 0.66                | 47.7        |
| Approach                        |      |           | 444          | 7.8  | 444           | 7.8  | 0.727     | 8.2         | NA               | 4.8               | 36.0       | 0.54      | 0.64           | 0.66                | 47.7        |
| All Vehicles                    |      |           | 1465         | 10.9 | 1465          | 10.9 | 0.747     | 5.7         | NA               | 5.9               | 44.1       | 0.36      | 0.44           | 0.44                | 49.0        |

Site Level of Service (LOS) Method: Delay (RTA NSW). Site LOS Method is specified in the Parameter Settings dialog (Options tab).

Vehicle movement LOS values are based on average delay per movement.

Minor Road Approach LOS values are based on average delay for all vehicle movements.

NA (TWSC): Level of Service is not defined for major road approaches or the intersection as a whole for Two-Way Sign Control (HCM LOS rule).

Two-Way Sign Control Capacity Model: SIDRA Standard.

Delay Model: SIDRA Standard (Control Delay: Geometric Delay is included).

Queue Model: SIDRA queue estimation methods are used for Back of Queue and Queue at Start of Gap.

Gap-Acceptance Capacity Formula: SIDRA Standard (Akçelik M3D).

HV (%) values are calculated for All Movement Classes of All Heavy Vehicle Model Designation.

Arrival Flows used in performance calculations are adjusted to include any Initial Queued Demand and Upstream Capacity Constraint effects.

---

**SIDRA INTERSECTION 9.1 | Copyright © 2000-2022 Akcelik and Associates Pty Ltd | sidrasolutions.com**

Organisation: AECOM AUSTRALIA PTY LTD | Licence: NETWORK / Enterprise Level 1 | Processed: Monday, 17 July 2023 9:51:55 AM

Project: C:\Users\Yeung\AECOM\ANZ-NAC-Sydney Metro-Sydney Metro C&SW Operational Monitoring - General\400\_Technical\432\_Traffic Analysis\SIDRA Modelling\01 Models (Geometry Only)\Block 1\Rev1\\_Review\09 SM C&SW\_SYD (Block 1)\_SH.sip9

# MOVEMENT SUMMARY

Site: SYD06 [SYD06 Sydenham Rd / Buckley St (Site Folder: Block 1 Model - 2023 AM Peak)]

Output produced by SIDRA INTERSECTION Version: 9.1.1.200

NA

Site Category: (None)

Give-Way (Two-Way)

| Vehicle Movement Performance |      |           |              |     |               |     |           |             |                  |                   |        |           |                |                     |             |
|------------------------------|------|-----------|--------------|-----|---------------|-----|-----------|-------------|------------------|-------------------|--------|-----------|----------------|---------------------|-------------|
| Mov ID                       | Turn | Mov Class | Demand Flows |     | Arrival Flows |     | Deg. Satn | Aver. Delay | Level of Service | 95% Back Of Queue |        | Prop. Que | Eff. Stop Rate | Aver. No. of Cycles | Aver. Speed |
|                              |      |           | [ Total HV ] | %   | [ Total HV ]  | %   | v/c       | sec         |                  | [ Veh. veh        | Dist ] |           |                |                     | km/h        |
|                              |      |           | veh/h        |     | veh/h         |     |           |             |                  | veh               | m      |           |                |                     |             |
| NorthWest: Sydenham Rd (NW)  |      |           |              |     |               |     |           |             |                  |                   |        |           |                |                     |             |
| 2                            | T1   | All MCs   | 726          | 8.7 | 726           | 8.7 | 0.404     | 0.1         | LOS A            | 0.0               | 0.0    | 0.00      | 0.00           | 0.00                | 59.7        |
| Approach                     |      |           | 726          | 8.7 | 726           | 8.7 | 0.404     | 0.1         | NA               | 0.0               | 0.0    | 0.00      | 0.00           | 0.00                | 59.7        |
| SouthWest: Buckley St (SW)   |      |           |              |     |               |     |           |             |                  |                   |        |           |                |                     |             |
| 4                            | L2   | All MCs   | 596          | 8.8 | 596           | 8.8 | 0.351     | 5.8         | LOS A            | 0.0               | 0.0    | 0.00      | 0.52           | 0.00                | 50.8        |
| 6                            | R2   | All MCs   | 399          | 8.4 | 399           | 8.4 | 0.234     | 5.9         | LOS A            | 0.0               | 0.0    | 0.00      | 0.63           | 0.00                | 43.3        |
| Approach                     |      |           | 995          | 8.7 | 995           | 8.7 | 0.351     | 5.8         | NA               | 0.0               | 0.0    | 0.00      | 0.57           | 0.00                | 48.6        |
| All Vehicles                 |      |           | 1721         | 8.7 | 1721          | 8.7 | 0.404     | 3.4         | NA               | 0.0               | 0.0    | 0.00      | 0.33           | 0.00                | 52.5        |

Site Level of Service (LOS) Method: Delay (RTA NSW). Site LOS Method is specified in the Parameter Settings dialog (Options tab).

Vehicle movement LOS values are based on average delay per movement.

Minor Road Approach LOS values are based on average delay for all vehicle movements.

NA (TWSC): Level of Service is not defined for major road approaches or the intersection as a whole for Two-Way Sign Control (HCM LOS rule).

Two-Way Sign Control Capacity Model: SIDRA Standard.

Delay Model: SIDRA Standard (Control Delay: Geometric Delay is included).

Queue Model: SIDRA queue estimation methods are used for Back of Queue and Queue at Start of Gap.

Gap-Acceptance Capacity Formula: SIDRA Standard (Akçelik M3D).

HV (%) values are calculated for All Movement Classes of All Heavy Vehicle Model Designation.

Arrival Flows used in performance calculations are adjusted to include any Initial Queued Demand and Upstream Capacity Constraint effects.

---

**SIDRA INTERSECTION 9.1 | Copyright © 2000-2022 Akcelik and Associates Pty Ltd | sidrasolutions.com**

Organisation: AECOM AUSTRALIA PTY LTD | Licence: NETWORK / Enterprise Level 1 | Processed: Thursday, 13 July 2023 12:04:34 PM

Project: C:\Users\Yeung\AECOM\ANZ-NAC-Sydney Metro-Sydney Metro C&SW Operational Monitoring - General\400\_Technical\432\_Traffic  
Analysis\SIDRA Modelling\01 Models (Geometry Only)\Block 1\Rev1\\_Review\09 SM C&SW\_SYD (Block 1)\_SH.sip9

# MOVEMENT SUMMARY

Site: SYD01 [SYD01 Railway Pde / Gleeson Ave (Site Folder: Block 1 Model - 2023 PM Peak)]

Output produced by SIDRA INTERSECTION Version: 9.1.1.200

Network: SYD-N1 [SYD Network 1 (Network Folder: Block 1 Network - 2023 PM Peak)]

TCS 3320

Site Category: (None)

Signals - EQUISAT (Fixed-Time/SCATS) Isolated Cycle Time = 90 seconds (Site User-Given Phase Times)

| Vehicle Movement Performance |      |           |                       |     |                       |     |           |             |                  |                   |               |           |                |                     |                  |
|------------------------------|------|-----------|-----------------------|-----|-----------------------|-----|-----------|-------------|------------------|-------------------|---------------|-----------|----------------|---------------------|------------------|
| Mov ID                       | Turn | Mov Class | Demand Flows          |     | Arrival Flows         |     | Deg. Satn | Aver. Delay | Level of Service | 95% Back Of Queue |               | Prop. Que | Eff. Stop Rate | Aver. No. of Cycles | Aver. Speed km/h |
|                              |      |           | [ Total HV ]<br>veh/h | %   | [ Total HV ]<br>veh/h | %   |           |             |                  | [ Veh. veh        | [ Dist ]<br>m |           |                |                     |                  |
| SouthEast: Gleeson Ave (SE)  |      |           |                       |     |                       |     |           |             |                  |                   |               |           |                |                     |                  |
| 1                            | L2   | All MCs   | 986                   | 4.1 | 986                   | 4.1 | 0.418     | 4.9         | LOS A            | 0.0               | 0.0           | 0.00      | 0.51           | 0.00                | 42.8             |
| Approach                     |      |           | 986                   | 4.1 | 986                   | 4.1 | 0.418     | 4.9         | LOS A            | 0.0               | 0.0           | 0.00      | 0.51           | 0.00                | 42.8             |
| NorthEast: Railway Pde (NE)  |      |           |                       |     |                       |     |           |             |                  |                   |               |           |                |                     |                  |
| 4                            | L2   | All MCs   | 971                   | 3.3 | 971                   | 3.3 | *0.355    | 9.4         | LOS A            | 6.4               | 45.7          | 0.32      | 0.64           | 0.32                | 36.5             |
| 5                            | T1   | All MCs   | 57                    | 7.4 | 57                    | 7.4 | 0.039     | 6.9         | LOS A            | 0.5               | 3.5           | 0.20      | 0.16           | 0.20                | 55.9             |
| Approach                     |      |           | 1027                  | 3.5 | 1027                  | 3.5 | 0.355     | 9.2         | LOS A            | 6.4               | 45.7          | 0.31      | 0.62           | 0.31                | 37.7             |
| All Vehicles                 |      |           | 2014                  | 3.8 | 2014                  | 3.8 | 0.418     | 7.1         | LOS A            | 6.4               | 45.7          | 0.16      | 0.57           | 0.16                | 40.3             |

Site Level of Service (LOS) Method: Delay (RTA NSW). Site LOS Method is specified in the Network Data dialog (Override Site Data tab).

Vehicle movement LOS values are based on average delay per movement.

Intersection and Approach LOS values are based on average delay for all vehicle movements.

Delay Model: SIDRA Standard (Control Delay: Geometric Delay is included).

Queue Model: SIDRA queue estimation methods are used for Back of Queue and Queue at Start of Green.

Gap-Acceptance Capacity Formula: SIDRA Standard (Akçelik M3D).

HV (%) values are calculated for All Movement Classes of All Heavy Vehicle Model Designation.

Arrival Flows used in performance calculations are adjusted to include any Initial Queued Demand and Upstream Capacity Constraint effects.

\* Critical Movement (Signal Timing)

| Pedestrian Movement Performance |                 |           |             |                  |                       |        |           |                |             |              |             |
|---------------------------------|-----------------|-----------|-------------|------------------|-----------------------|--------|-----------|----------------|-------------|--------------|-------------|
| Mov ID                          | Crossing        | Dem. Flow | Aver. Delay | Level of Service | AVERAGE BACK OF QUEUE |        | Prop. Que | Eff. Stop Rate | Travel Time | Travel Dist. | Aver. Speed |
|                                 |                 | ped/h     | sec         |                  | [ Ped                 | Dist ] |           |                | sec         | m            | m/sec       |
|                                 |                 |           |             |                  | ped                   | m      |           |                |             |              |             |
| NorthEast: Railway Pde (NE)     |                 |           |             |                  |                       |        |           |                |             |              |             |
| P2                              | Full            | 195       | 37.7        | LOS D            | 0.5                   | 0.5    | 0.92      | 0.92           | 54.3        | 20.0         | 0.37        |
| P2S                             | Slip/<br>Bypass | 195       | 37.7        | LOS D            | 0.5                   | 0.5    | 0.92      | 0.92           | 54.3        | 20.0         | 0.37        |
| All Pedestrians                 |                 | 389       | 37.7        | LOS D            | 0.5                   | 0.5    | 0.92      | 0.92           | 54.3        | 20.0         | 0.37        |

Level of Service (LOS) Method: SIDRA Pedestrian LOS Method (Based on Average Delay)

Pedestrian movement LOS values are based on average delay per pedestrian movement.

Intersection LOS value for Pedestrians is based on average delay for all pedestrian movements.

---

**SIDRA INTERSECTION 9.1 | Copyright © 2000-2022 Akcelik and Associates Pty Ltd | sidrasolutions.com**

Organisation: AECOM AUSTRALIA PTY LTD | Licence: NETWORK / Enterprise Level 1 | Processed: Monday, 17 July 2023 10:15:39 AM

Project: C:\Users\YeungM\AECOM\ANZ-NAC-Sydney Metro-Sydney Metro C&SW Operational Monitoring - General\400\_Technical\432\_Traffic Analysis\SIDRA Modelling\01 Models (Geometry Only)\Block 1\Rev1\Review\09 SM C&SW\_SYD (Block 1)\_SH.sip9

# MOVEMENT SUMMARY

Site: SYD02 [SYD02 Burrows Ave / Gleeson Ave (Site Folder: Block 1 Model - 2023 PM Peak)]

Output produced by SIDRA INTERSECTION Version: 9.1.1.200

Network: SYD-N1 [SYD Network 1 (Network Folder: Block 1 Network - 2023 PM Peak)]

TCS 1152

Site Category: (None)

Signals - EQUISAT (Fixed-Time/SCATS) Coordinated Cycle Time = 100 seconds (Site User-Given Phase Times)

| Vehicle Movement Performance |      |           |                       |      |                       |      |           |             |                  |                   |               |           |                |                     |                  |
|------------------------------|------|-----------|-----------------------|------|-----------------------|------|-----------|-------------|------------------|-------------------|---------------|-----------|----------------|---------------------|------------------|
| Mov ID                       | Turn | Mov Class | Demand Flows          |      | Arrival Flows         |      | Deg. Satn | Aver. Delay | Level of Service | 95% Back Of Queue |               | Prop. Que | Eff. Stop Rate | Aver. No. of Cycles | Aver. Speed km/h |
|                              |      |           | [ Total HV ]<br>veh/h | %    | [ Total HV ]<br>veh/h | %    |           |             |                  | [ Veh. veh        | [ Dist ]<br>m |           |                |                     |                  |
| SouthEast: Gleeson Ave (SE)  |      |           |                       |      |                       |      |           |             |                  |                   |               |           |                |                     |                  |
| 2                            | T1   | All MCs   | 679                   | 4.3  | 679                   | 4.3  | 0.336     | 13.8        | LOS A            | 9.2               | 66.8          | 0.60      | 0.52           | 0.60                | 22.4             |
| Approach                     |      |           | 679                   | 4.3  | 679                   | 4.3  | 0.336     | 13.8        | LOS A            | 9.2               | 66.8          | 0.60      | 0.52           | 0.60                | 22.4             |
| NorthEast: Burrows Ave (NE)  |      |           |                       |      |                       |      |           |             |                  |                   |               |           |                |                     |                  |
| 4                            | L2   | All MCs   | 28                    | 0.0  | 28                    | 0.0  | 0.118     | 54.9        | LOS D            | 1.3               | 8.8           | 0.92      | 0.71           | 0.92                | 15.3             |
| 6                            | R2   | All MCs   | 281                   | 0.4  | 281                   | 0.4  | *0.554    | 53.2        | LOS D            | 6.8               | 47.5          | 0.98      | 0.80           | 0.98                | 10.1             |
| Approach                     |      |           | 309                   | 0.3  | 309                   | 0.3  | 0.554     | 53.3        | LOS D            | 6.8               | 47.5          | 0.97      | 0.79           | 0.97                | 10.6             |
| NorthWest: Gleeson Ave (NW)  |      |           |                       |      |                       |      |           |             |                  |                   |               |           |                |                     |                  |
| 7                            | L2   | All MCs   | 166                   | 4.4  | 166                   | 4.4  | 0.494     | 6.9         | LOS A            | 5.9               | 42.4          | 0.28      | 0.40           | 0.28                | 35.2             |
| 8                            | T1   | All MCs   | 804                   | 3.0  | 804                   | 3.0  | *0.494    | 4.7         | LOS A            | 6.4               | 46.0          | 0.28      | 0.30           | 0.28                | 42.0             |
| Approach                     |      |           | 971                   | 3.3  | 971                   | 3.3  | 0.494     | 5.1         | LOS A            | 6.4               | 46.0          | 0.28      | 0.32           | 0.28                | 40.4             |
| SouthWest: Burrows Ave (SW)  |      |           |                       |      |                       |      |           |             |                  |                   |               |           |                |                     |                  |
| 10                           | L2   | All MCs   | 26                    | 36.0 | 26                    | 36.0 | 0.131     | 54.3        | LOS D            | 0.8               | 7.1           | 0.96      | 0.69           | 0.96                | 11.3             |
| 11                           | T1   | All MCs   | 5                     | 0.0  | 5                     | 0.0  | *0.131    | 41.7        | LOS C            | 0.8               | 7.1           | 0.95      | 0.69           | 0.95                | 17.4             |
| 12                           | R2   | All MCs   | 16                    | 33.3 | 16                    | 33.3 | 0.072     | 44.2        | LOS D            | 0.7               | 6.0           | 0.88      | 0.69           | 0.88                | 16.8             |
| Approach                     |      |           | 47                    | 31.1 | 47                    | 31.1 | 0.131     | 49.5        | LOS D            | 0.8               | 7.1           | 0.93      | 0.69           | 0.93                | 13.9             |
| All Vehicles                 |      |           | 2006                  | 3.8  | 2006                  | 3.8  | 0.554     | 16.5        | LOS B            | 9.2               | 66.8          | 0.51      | 0.47           | 0.51                | 23.4             |

Site Level of Service (LOS) Method: Delay (RTA NSW). Site LOS Method is specified in the Network Data dialog (Override Site Data tab).

Vehicle movement LOS values are based on average delay per movement.

Intersection and Approach LOS values are based on average delay for all vehicle movements.

Delay Model: SIDRA Standard (Control Delay: Geometric Delay is included).

Queue Model: SIDRA queue estimation methods are used for Back of Queue and Queue at Start of Green.

Gap-Acceptance Capacity Formula: SIDRA Standard (Akçelik M3D).

HV (%) values are calculated for All Movement Classes of All Heavy Vehicle Model Designation.

Arrival Flows used in performance calculations are adjusted to include any Initial Queued Demand and Upstream Capacity Constraint effects.

\* Critical Movement (Signal Timing)



| Pedestrian Movement Performance |          |           |             |                  |                       |        |           |                |             |              |             |
|---------------------------------|----------|-----------|-------------|------------------|-----------------------|--------|-----------|----------------|-------------|--------------|-------------|
| Mov ID                          | Crossing | Dem. Flow | Aver. Delay | Level of Service | AVERAGE BACK OF QUEUE |        | Prop. Que | Eff. Stop Rate | Travel Time | Travel Dist. | Aver. Speed |
|                                 |          | ped/h     | sec         |                  | [ Ped                 | Dist ] |           |                | sec         | m            | m/sec       |
|                                 |          |           |             |                  | ped                   | m      |           |                |             |              |             |
| SouthEast: Gleeson Ave (SE)     |          |           |             |                  |                       |        |           |                |             |              |             |
| P1                              | Full     | 17        | 37.9        | LOS D            | 0.0                   | 0.0    | 0.87      | 0.87           | 54.5        | 20.0         | 0.37        |
| NorthEast: Burrows Ave (NE)     |          |           |             |                  |                       |        |           |                |             |              |             |
| P2                              | Full     | 140       | 38.1        | LOS D            | 0.3                   | 0.3    | 0.88      | 0.88           | 54.7        | 20.0         | 0.37        |
| NorthWest: Gleeson Ave (NW)     |          |           |             |                  |                       |        |           |                |             |              |             |
| P3                              | Full     | 201       | 35.6        | LOS D            | 0.5                   | 0.5    | 0.85      | 0.85           | 52.2        | 20.0         | 0.38        |
| SouthWest: Burrows Ave (SW)     |          |           |             |                  |                       |        |           |                |             |              |             |
| P4                              | Full     | 129       | 39.8        | LOS D            | 0.3                   | 0.3    | 0.89      | 0.89           | 56.5        | 20.0         | 0.35        |
| All Pedestrians                 |          | 487       | 37.5        | LOS D            | 0.5                   | 0.5    | 0.87      | 0.87           | 54.2        | 20.0         | 0.37        |

Level of Service (LOS) Method: SIDRA Pedestrian LOS Method (Based on Average Delay)  
 Pedestrian movement LOS values are based on average delay per pedestrian movement.  
 Intersection LOS value for Pedestrians is based on average delay for all pedestrian movements.

# MOVEMENT SUMMARY

Site: SYD03 [SYD03 Burrows Ave / George St (Site Folder: Block 1 Model - 2023 PM Peak)]

Output produced by SIDRA INTERSECTION Version: 9.1.1.200

NA

Site Category: (None)

Give-Way (Two-Way)

| Vehicle Movement Performance |      |           |              |      |               |      |           |             |                  |                   |          |           |                |                     |             |
|------------------------------|------|-----------|--------------|------|---------------|------|-----------|-------------|------------------|-------------------|----------|-----------|----------------|---------------------|-------------|
| Mov ID                       | Turn | Mov Class | Demand Flows |      | Arrival Flows |      | Deg. Satn | Aver. Delay | Level of Service | 95% Back Of Queue |          | Prop. Que | Eff. Stop Rate | Aver. No. of Cycles | Aver. Speed |
|                              |      |           | [ Total HV ] | %    | [ Total HV ]  | %    | v/c       | sec         |                  | [ Veh. ]          | [ Dist ] |           |                |                     | km/h        |
|                              |      |           | veh/h        |      | veh/h         |      |           |             |                  | veh               | m        |           |                |                     |             |
| SouthEast: George St (SE)    |      |           |              |      |               |      |           |             |                  |                   |          |           |                |                     |             |
| 4                            | L2   | All MCs   | 5            | 0.0  | 5             | 0.0  | 0.007     | 8.6         | LOSA             | 0.0               | 0.1      | 0.31      | 0.86           | 0.31                | 30.4        |
| 6                            | R2   | All MCs   | 1            | 0.0  | 1             | 0.0  | 0.007     | 9.7         | LOSA             | 0.0               | 0.1      | 0.31      | 0.86           | 0.31                | 26.4        |
| Approach                     |      |           | 6            | 0.0  | 6             | 0.0  | 0.007     | 8.8         | LOSA             | 0.0               | 0.1      | 0.31      | 0.86           | 0.31                | 29.8        |
| NorthEast: Burrows Ave (NE)  |      |           |              |      |               |      |           |             |                  |                   |          |           |                |                     |             |
| 7                            | L2   | All MCs   | 4            | 0.0  | 4             | 0.0  | 0.271     | 3.9         | LOSA             | 1.6               | 11.1     | 0.22      | 0.09           | 0.22                | 40.5        |
| 8                            | T1   | All MCs   | 298          | 1.4  | 298           | 1.4  | 0.271     | 0.5         | LOSA             | 1.6               | 11.1     | 0.22      | 0.09           | 0.22                | 46.8        |
| Approach                     |      |           | 302          | 1.4  | 302           | 1.4  | 0.271     | 0.5         | NA               | 1.6               | 11.1     | 0.22      | 0.09           | 0.22                | 46.7        |
| SouthWest: Burrows Ave (SW)  |      |           |              |      |               |      |           |             |                  |                   |          |           |                |                     |             |
| 2                            | T1   | All MCs   | 163          | 0.0  | 163           | 0.0  | 0.169     | 0.4         | LOSA             | 0.7               | 5.4      | 0.17      | 0.13           | 0.17                | 45.8        |
| 3                            | R2   | All MCs   | 23           | 50.0 | 23            | 50.0 | 0.169     | 7.1         | LOSA             | 0.7               | 5.4      | 0.17      | 0.13           | 0.17                | 36.0        |
| Approach                     |      |           | 186          | 6.2  | 186           | 6.2  | 0.169     | 1.2         | NA               | 0.7               | 5.4      | 0.17      | 0.13           | 0.17                | 43.9        |
| All Vehicles                 |      |           | 495          | 3.2  | 495           | 3.2  | 0.271     | 0.9         | NA               | 1.6               | 11.1     | 0.21      | 0.12           | 0.21                | 45.2        |

Site Level of Service (LOS) Method: Delay (RTA NSW). Site LOS Method is specified in the Parameter Settings dialog (Options tab).

Vehicle movement LOS values are based on average delay per movement.

Minor Road Approach LOS values are based on average delay for all vehicle movements.

NA (TWSC): Level of Service is not defined for major road approaches or the intersection as a whole for Two-Way Sign Control (HCM LOS rule).

Two-Way Sign Control Capacity Model: SIDRA Standard.

Delay Model: SIDRA Standard (Control Delay: Geometric Delay is included).

Queue Model: SIDRA queue estimation methods are used for Back of Queue and Queue at Start of Gap.

Gap-Acceptance Capacity Formula: SIDRA Standard (Akçelik M3D).

HV (%) values are calculated for All Movement Classes of All Heavy Vehicle Model Designation.

Arrival Flows used in performance calculations are adjusted to include any Initial Queued Demand and Upstream Capacity Constraint effects.

---

**SIDRA INTERSECTION 9.1 | Copyright © 2000-2022 Akcelik and Associates Pty Ltd | sidrasolutions.com**

Organisation: AECOM AUSTRALIA PTY LTD | Licence: NETWORK / Enterprise Level 1 | Processed: Friday, 14 July 2023 5:39:01 PM

Project: C:\Users\Yeung\AECOM\ANZ-NAC-Sydney Metro-Sydney Metro C&SW Operational Monitoring - General\400\_Technical\432\_Traffic Analysis\SIDRA Modelling\01 Models (Geometry Only)\Block 1\Rev1\\_Review\09 SM C&SW\_SYD (Block 1)\_SH.sip9

# MOVEMENT SUMMARY

 Site: SYD04 [SYD04 Pedestrian Mid-block Crossing at Sydenham Rd (Site Folder: Block 1 Model - 2023 PM Peak)]

Output produced by SIDRA INTERSECTION Version: 9.1.1.200

TCS 4946

Site Category: (None)

Pedestrian Crossing (Signalised) - EQUISAT (Fixed-Time/SCATS) Isolated Cycle Time = 111 seconds (Site User-Given Phase Times)

| Vehicle Movement Performance |      |           |                       |     |                       |     |           |             |                  |                   |               |           |                |                     |             |
|------------------------------|------|-----------|-----------------------|-----|-----------------------|-----|-----------|-------------|------------------|-------------------|---------------|-----------|----------------|---------------------|-------------|
| Mov ID                       | Turn | Mov Class | Demand Flows          |     | Arrival Flows         |     | Deg. Satn | Aver. Delay | Level of Service | 95% Back Of Queue |               | Prop. Que | Eff. Stop Rate | Aver. No. of Cycles | Aver. Speed |
|                              |      |           | [ Total HV ]<br>veh/h | %   | [ Total HV ]<br>veh/h | %   |           |             |                  | [ Veh. ]<br>veh   | [ Dist ]<br>m |           |                |                     |             |
| NorthWest: Sydenham Rd (NW)  |      |           |                       |     |                       |     |           |             |                  |                   |               |           |                |                     |             |
| 8                            | T1   | All MCs   | 1046                  | 4.2 | 1046                  | 4.2 | * 0.393   | 5.3         | LOS A            | 7.5               | 54.5          | 0.43      | 0.40           | 0.43                | 46.7        |
| Approach                     |      |           | 1046                  | 4.2 | 1046                  | 4.2 | 0.393     | 5.3         | LOS A            | 7.5               | 54.5          | 0.43      | 0.40           | 0.43                | 46.7        |
| All Vehicles                 |      |           | 1046                  | 4.2 | 1046                  | 4.2 | 0.393     | 5.3         | LOS A            | 7.5               | 54.5          | 0.43      | 0.40           | 0.43                | 46.7        |

Site Level of Service (LOS) Method: Delay (RTA NSW). Site LOS Method is specified in the Parameter Settings dialog (Options tab).

Vehicle movement LOS values are based on average delay per movement.

Intersection and Approach LOS values are based on average delay for all vehicle movements.

Delay Model: SIDRA Standard (Control Delay: Geometric Delay is included).

Queue Model: SIDRA queue estimation methods are used for Back of Queue and Queue at Start of Green.

Gap-Acceptance Capacity Formula: SIDRA Standard (Akçelik M3D).

HV (%) values are calculated for All Movement Classes of All Heavy Vehicle Model Designation.

Arrival Flows used in performance calculations are adjusted to include any Initial Queued Demand and Upstream Capacity Constraint effects.

\* Critical Movement (Signal Timing)

| Pedestrian Movement Performance |          |            |           |             |                  |                       |        |           |                |             |              |             |
|---------------------------------|----------|------------|-----------|-------------|------------------|-----------------------|--------|-----------|----------------|-------------|--------------|-------------|
| Mov ID                          | Crossing | Input Vol. | Dem. Flow | Aver. Delay | Level of Service | AVERAGE BACK OF QUEUE |        | Prop. Que | Eff. Stop Rate | Travel Time | Travel Dist. | Aver. Speed |
|                                 |          | ped/h      | ped/h     | sec         |                  | [ Ped                 | Dist ] |           |                | sec         | m            | m/sec       |
|                                 |          |            |           |             |                  | ped                   | m      |           |                |             |              |             |
| SouthEast: Sydenham Rd (SE)     |          |            |           |             |                  |                       |        |           |                |             |              |             |
| P1                              | Full     | 18         | 19        | 32.9        | LOS D            | 0.0                   | 0.0    | 0.84      | 0.84           | 199.5       | 200.0        | 1.00        |
| All                             |          | 18         | 19        | 32.9        | LOS D            | 0.0                   | 0.0    | 0.84      | 0.84           | 199.5       | 200.0        | 1.00        |
| Pedestrians                     |          |            |           |             |                  |                       |        |           |                |             |              |             |

Level of Service (LOS) Method: SIDRA Pedestrian LOS Method (Based on Average Delay)

Pedestrian movement LOS values are based on average delay per pedestrian movement.

Intersection LOS value for Pedestrians is based on average delay for all pedestrian movements.

**SIDRA INTERSECTION 9.1 | Copyright © 2000-2022 Kcelik and Associates Pty Ltd | sidrasolutions.com**

Organisation: AECOM AUSTRALIA PTY LTD | Licence: NETWORK / Enterprise Level 1 | Processed: Thursday, 13 July 2023 11:45:00 AM

Project: C:\Users\YeungMAE\COMANZ-NAC-Sydney Metro-Sydney Metro C&SW Operational Monitoring - General\400\_Technical\432\_Traffic Analysis\SIDRA Modelling\01 Models (Geometry Only)\Block 1\Rev1\_Review\09 SM C&SW\_SYD (Block 1)\_SH.sip9

# MOVEMENT SUMMARY

Site: SYD05 [SYD05 Marrickville Rd / Buckley St (Site Folder: Block 1 Model - 2023 PM Peak)]

Output produced by SIDRA INTERSECTION Version: 9.1.1.200

NA

Site Category: (None)

Give-Way (Two-Way)

| Vehicle Movement Performance    |      |           |              |     |               |     |           |             |                  |                   |        |           |                |                     |             |
|---------------------------------|------|-----------|--------------|-----|---------------|-----|-----------|-------------|------------------|-------------------|--------|-----------|----------------|---------------------|-------------|
| Mov ID                          | Turn | Mov Class | Demand Flows |     | Arrival Flows |     | Deg. Satn | Aver. Delay | Level of Service | 95% Back Of Queue |        | Prop. Que | Eff. Stop Rate | Aver. No. of Cycles | Aver. Speed |
|                                 |      |           | [ Total HV ] | %   | [ Total HV ]  | %   | v/c       | sec         |                  | [ Veh. veh        | Dist ] |           |                |                     | km/h        |
|                                 |      |           | veh/h        |     | veh/h         |     |           |             |                  | veh               | m      |           |                |                     |             |
| SouthEast: Marrickville Rd (SE) |      |           |              |     |               |     |           |             |                  |                   |        |           |                |                     |             |
| 2                               | T1   | All MCs   | 822          | 1.9 | 822           | 1.9 | 0.430     | 0.1         | LOSA             | 0.0               | 0.0    | 0.00      | 0.00           | 0.00                | 59.7        |
| 3                               | R2   | All MCs   | 505          | 2.5 | 505           | 2.5 | 0.607     | 6.4         | LOSA             | 2.9               | 20.8   | 0.29      | 0.58           | 0.30                | 44.6        |
| Approach                        |      |           | 1327         | 2.1 | 1327          | 2.1 | 0.607     | 2.5         | NA               | 2.9               | 20.8   | 0.11      | 0.22           | 0.11                | 53.7        |
| NorthWest: Marrickville Rd (NW) |      |           |              |     |               |     |           |             |                  |                   |        |           |                |                     |             |
| 7                               | L2   | All MCs   | 306          | 4.8 | 306           | 4.8 | 0.586     | 6.5         | LOSA             | 2.1               | 15.2   | 0.32      | 0.55           | 0.34                | 49.0        |
| Approach                        |      |           | 306          | 4.8 | 306           | 4.8 | 0.586     | 6.5         | NA               | 2.1               | 15.2   | 0.32      | 0.55           | 0.34                | 49.0        |
| All Vehicles                    |      |           | 1634         | 2.6 | 1634          | 2.6 | 0.607     | 3.2         | NA               | 2.9               | 20.8   | 0.15      | 0.28           | 0.16                | 52.6        |

Site Level of Service (LOS) Method: Delay (RTA NSW). Site LOS Method is specified in the Parameter Settings dialog (Options tab).

Vehicle movement LOS values are based on average delay per movement.

Minor Road Approach LOS values are based on average delay for all vehicle movements.

NA (TWSC): Level of Service is not defined for major road approaches or the intersection as a whole for Two-Way Sign Control (HCM LOS rule).

Two-Way Sign Control Capacity Model: SIDRA Standard.

Delay Model: SIDRA Standard (Control Delay: Geometric Delay is included).

Queue Model: SIDRA queue estimation methods are used for Back of Queue and Queue at Start of Gap.

Gap-Acceptance Capacity Formula: SIDRA Standard (Akçelik M3D).

HV (%) values are calculated for All Movement Classes of All Heavy Vehicle Model Designation.

Arrival Flows used in performance calculations are adjusted to include any Initial Queued Demand and Upstream Capacity Constraint effects.

---

**SIDRA INTERSECTION 9.1 | Copyright © 2000-2022 Akcelik and Associates Pty Ltd | sidrasolutions.com**

Organisation: AECOM AUSTRALIA PTY LTD | Licence: NETWORK / Enterprise Level 1 | Processed: Monday, 17 July 2023 9:51:56 AM

Project: C:\Users\Yeung\AECOM\ANZ-NAC-Sydney Metro-Sydney Metro C&SW Operational Monitoring - General\400\_Technical\432\_Traffic Analysis\SIDRA Modelling\01 Models (Geometry Only)\Block 1\Rev1\\_Review\09 SM C&SW\_SYD (Block 1)\_SH.sip9

# MOVEMENT SUMMARY

Site: SYD06 [SYD06 Sydenham Rd / Buckley St (Site Folder: Block 1 Model - 2023 PM Peak)]

Output produced by SIDRA INTERSECTION Version: 9.1.1.200

NA

Site Category: (None)

Give-Way (Two-Way)

| Vehicle Movement Performance |      |           |              |     |               |     |           |             |                  |                   |            |           |                |                     |             |
|------------------------------|------|-----------|--------------|-----|---------------|-----|-----------|-------------|------------------|-------------------|------------|-----------|----------------|---------------------|-------------|
| Mov ID                       | Turn | Mov Class | Demand Flows |     | Arrival Flows |     | Deg. Satn | Aver. Delay | Level of Service | 95% Back Of Queue |            | Prop. Que | Eff. Stop Rate | Aver. No. of Cycles | Aver. Speed |
|                              |      |           | [ Total HV ] | %   | [ Total HV ]  | %   | v/c       | sec         |                  | [ Veh. veh        | [ Dist ] m |           |                |                     | km/h        |
| NorthWest: Sydenham Rd (NW)  |      |           |              |     |               |     |           |             |                  |                   |            |           |                |                     |             |
| 2                            | T1   | All MCs   | 778          | 3.4 | 778           | 3.4 | 0.412     | 0.1         | LOSA             | 0.0               | 0.0        | 0.00      | 0.00           | 0.00                | 59.7        |
| Approach                     |      |           | 778          | 3.4 | 778           | 3.4 | 0.412     | 0.1         | NA               | 0.0               | 0.0        | 0.00      | 0.00           | 0.00                | 59.7        |
| SouthWest: Buckley St (SW)   |      |           |              |     |               |     |           |             |                  |                   |            |           |                |                     |             |
| 4                            | L2   | All MCs   | 548          | 5.4 | 548           | 5.4 | 0.312     | 5.7         | LOSA             | 0.0               | 0.0        | 0.00      | 0.53           | 0.00                | 51.0        |
| 6                            | R2   | All MCs   | 367          | 6.9 | 367           | 6.9 | 0.212     | 5.8         | LOSA             | 0.0               | 0.0        | 0.00      | 0.63           | 0.00                | 43.5        |
| Approach                     |      |           | 916          | 6.0 | 916           | 6.0 | 0.312     | 5.8         | NA               | 0.0               | 0.0        | 0.00      | 0.57           | 0.00                | 48.8        |
| All Vehicles                 |      |           | 1694         | 4.8 | 1694          | 4.8 | 0.412     | 3.2         | NA               | 0.0               | 0.0        | 0.00      | 0.31           | 0.00                | 53.0        |

Site Level of Service (LOS) Method: Delay (RTA NSW). Site LOS Method is specified in the Parameter Settings dialog (Options tab).

Vehicle movement LOS values are based on average delay per movement.

Minor Road Approach LOS values are based on average delay for all vehicle movements.

NA (TWSC): Level of Service is not defined for major road approaches or the intersection as a whole for Two-Way Sign Control (HCM LOS rule).

Two-Way Sign Control Capacity Model: SIDRA Standard.

Delay Model: SIDRA Standard (Control Delay: Geometric Delay is included).

Queue Model: SIDRA queue estimation methods are used for Back of Queue and Queue at Start of Gap.

Gap-Acceptance Capacity Formula: SIDRA Standard (Akçelik M3D).

HV (%) values are calculated for All Movement Classes of All Heavy Vehicle Model Designation.

Arrival Flows used in performance calculations are adjusted to include any Initial Queued Demand and Upstream Capacity Constraint effects.



---

**SIDRA INTERSECTION 9.1 | Copyright © 2000-2022 Akcelik and Associates Pty Ltd | sidrasolutions.com**

Organisation: AECOM AUSTRALIA PTY LTD | Licence: NETWORK / Enterprise Level 1 | Processed: Thursday, 13 July 2023 11:45:01 AM

Project: C:\Users\Yeung\AECOM\ANZ-NAC-Sydney Metro-Sydney Metro C&SW Operational Monitoring - General\400\_Technical\432\_Traffic  
Analysis\SIDRA Modelling\01 Models (Geometry Only)\Block 1\Rev1\\_Review\09 SM C&SW\_SYD (Block 1)\_SH.sip9

# MOVEMENT SUMMARY

Site: SYD01 [SYD01 Railway Pde / Gleeson Ave (Site Folder: Block 1 Model - 2023 Weekend Peak)]

Output produced by SIDRA INTERSECTION Version: 9.1.1.200

Network: SYD-N1 [SYD Network 1 (Network Folder: Block 1 Network - 2023 Weekend Peak)]

TCS 3320

Site Category: (None)

Signals - EQUISAT (Fixed-Time/SCATS) Isolated Cycle Time = 113 seconds (Site User-Given Phase Times)

| Vehicle Movement Performance |      |           |                       |     |                       |     |           |             |                  |                   |               |           |                |                     |             |
|------------------------------|------|-----------|-----------------------|-----|-----------------------|-----|-----------|-------------|------------------|-------------------|---------------|-----------|----------------|---------------------|-------------|
| Mov ID                       | Turn | Mov Class | Demand Flows          |     | Arrival Flows         |     | Deg. Satn | Aver. Delay | Level of Service | 95% Back Of Queue |               | Prop. Que | Eff. Stop Rate | Aver. No. of Cycles | Aver. Speed |
|                              |      |           | [ Total HV ]<br>veh/h | %   | [ Total HV ]<br>veh/h | %   |           |             |                  | [ Veh. veh        | [ Dist ]<br>m |           |                |                     |             |
| SouthEast: Gleeson Ave (SE)  |      |           |                       |     |                       |     |           |             |                  |                   |               |           |                |                     |             |
| 1                            | L2   | All MCs   | 903                   | 2.0 | 903                   | 2.0 | 0.375     | 4.8         | LOS A            | 0.0               | 0.0           | 0.00      | 0.52           | 0.00                | 43.2        |
| Approach                     |      |           | 903                   | 2.0 | 903                   | 2.0 | 0.375     | 4.8         | LOS A            | 0.0               | 0.0           | 0.00      | 0.52           | 0.00                | 43.2        |
| NorthEast: Railway Pde (NE)  |      |           |                       |     |                       |     |           |             |                  |                   |               |           |                |                     |             |
| 4                            | L2   | All MCs   | 948                   | 6.7 | 948                   | 6.7 | *0.331    | 7.2         | LOS A            | 4.7               | 35.0          | 0.19      | 0.60           | 0.19                | 39.5        |
| 5                            | T1   | All MCs   | 39                    | 0.0 | 39                    | 0.0 | 0.023     | 4.0         | LOS A            | 0.3               | 1.8           | 0.13      | 0.10           | 0.13                | 57.8        |
| Approach                     |      |           | 987                   | 6.4 | 987                   | 6.4 | 0.331     | 7.1         | LOS A            | 4.7               | 35.0          | 0.19      | 0.58           | 0.19                | 40.4        |
| All Vehicles                 |      |           | 1891                  | 4.3 | 1891                  | 4.3 | 0.375     | 6.0         | LOS A            | 4.7               | 35.0          | 0.10      | 0.55           | 0.10                | 41.8        |

Site Level of Service (LOS) Method: Delay (RTA NSW). Site LOS Method is specified in the Network Data dialog (Override Site Data tab).

Vehicle movement LOS values are based on average delay per movement.

Intersection and Approach LOS values are based on average delay for all vehicle movements.

Delay Model: SIDRA Standard (Control Delay: Geometric Delay is included).

Queue Model: SIDRA queue estimation methods are used for Back of Queue and Queue at Start of Green.

Gap-Acceptance Capacity Formula: SIDRA Standard (Akçelik M3D).

HV (%) values are calculated for All Movement Classes of All Heavy Vehicle Model Designation.

Arrival Flows used in performance calculations are adjusted to include any Initial Queued Demand and Upstream Capacity Constraint effects.

\* Critical Movement (Signal Timing)

| Pedestrian Movement Performance |                 |           |             |                  |                       |        |           |                |             |              |             |
|---------------------------------|-----------------|-----------|-------------|------------------|-----------------------|--------|-----------|----------------|-------------|--------------|-------------|
| Mov ID                          | Crossing        | Dem. Flow | Aver. Delay | Level of Service | AVERAGE BACK OF QUEUE |        | Prop. Que | Eff. Stop Rate | Travel Time | Travel Dist. | Aver. Speed |
|                                 |                 | ped/h     | sec         |                  | [ Ped                 | Dist ] |           |                | sec         | m            | m/sec       |
|                                 |                 |           |             |                  | ped                   | m      |           |                |             |              |             |
| NorthEast: Railway Pde (NE)     |                 |           |             |                  |                       |        |           |                |             |              |             |
| P2                              | Full            | 61        | 48.9        | LOS E            | 0.2                   | 0.2    | 0.93      | 0.93           | 65.6        | 20.0         | 0.30        |
| P2S                             | Slip/<br>Bypass | 61        | 48.9        | LOS E            | 0.2                   | 0.2    | 0.93      | 0.93           | 65.6        | 20.0         | 0.30        |
| All Pedestrians                 |                 | 122       | 48.9        | LOS E            | 0.2                   | 0.2    | 0.93      | 0.93           | 65.6        | 20.0         | 0.30        |

Level of Service (LOS) Method: SIDRA Pedestrian LOS Method (Based on Average Delay)

Pedestrian movement LOS values are based on average delay per pedestrian movement.

Intersection LOS value for Pedestrians is based on average delay for all pedestrian movements.

---

**SIDRA INTERSECTION 9.1 | Copyright © 2000-2022 Akcelik and Associates Pty Ltd | sidrasolutions.com**

Organisation: AECOM AUSTRALIA PTY LTD | Licence: NETWORK / Enterprise Level 1 | Processed: Monday, 17 July 2023 10:22:14 AM

Project: C:\Users\YeungM\AECOM\ANZ-NAC-Sydney Metro-Sydney Metro C&SW Operational Monitoring - General\400\_Technical\432\_Traffic Analysis\SIDRA Modelling\01 Models (Geometry Only)\Block 1\Rev1\Review\09 SM C&SW\_SYD (Block 1)\_SH.sip9

# MOVEMENT SUMMARY

Site: SYD02 [SYD02 Burrows Ave / Gleeson Ave (Site Folder: Block 1 Model - 2023 Weekend Peak)]

Output produced by SIDRA INTERSECTION Version: 9.1.1.200

Network: SYD-N1 [SYD Network 1 (Network Folder: Block 1 Network - 2023 Weekend Peak)]

TCS 1152

Site Category: (None)

Signals - EQUISAT (Fixed-Time/SCATS) Coordinated Cycle Time = 110 seconds (Site User-Given Phase Times)

| Vehicle Movement Performance |      |           |                       |      |                       |      |           |             |                  |                   |               |           |                |                     |                  |
|------------------------------|------|-----------|-----------------------|------|-----------------------|------|-----------|-------------|------------------|-------------------|---------------|-----------|----------------|---------------------|------------------|
| Mov ID                       | Turn | Mov Class | Demand Flows          |      | Arrival Flows         |      | Deg. Satn | Aver. Delay | Level of Service | 95% Back Of Queue |               | Prop. Que | Eff. Stop Rate | Aver. No. of Cycles | Aver. Speed km/h |
|                              |      |           | [ Total HV ]<br>veh/h | %    | [ Total HV ]<br>veh/h | %    |           |             |                  | [ Veh. veh        | [ Dist ]<br>m |           |                |                     |                  |
| SouthEast: Gleeson Ave (SE)  |      |           |                       |      |                       |      |           |             |                  |                   |               |           |                |                     |                  |
| 2                            | T1   | All MCs   | 649                   | 1.1  | 649                   | 1.1  | 0.289     | 12.2        | LOS A            | 8.6               | 60.8          | 0.54      | 0.47           | 0.54                | 24.1             |
| Approach                     |      |           | 649                   | 1.1  | 649                   | 1.1  | 0.289     | 12.2        | LOS A            | 8.6               | 60.8          | 0.54      | 0.47           | 0.54                | 24.1             |
| NorthEast: Burrows Ave (NE)  |      |           |                       |      |                       |      |           |             |                  |                   |               |           |                |                     |                  |
| 4                            | L2   | All MCs   | 31                    | 10.3 | 31                    | 10.3 | 0.126     | 51.1        | LOS D            | 1.5               | 11.1          | 0.90      | 0.72           | 0.90                | 14.7             |
| 6                            | R2   | All MCs   | 234                   | 0.5  | 234                   | 0.5  | *0.481    | 51.0        | LOS D            | 6.9               | 48.6          | 0.95      | 0.78           | 0.95                | 9.8              |
| Approach                     |      |           | 264                   | 1.6  | 264                   | 1.6  | 0.481     | 51.0        | LOS D            | 6.9               | 48.6          | 0.94      | 0.78           | 0.94                | 10.5             |
| NorthWest: Gleeson Ave (NW)  |      |           |                       |      |                       |      |           |             |                  |                   |               |           |                |                     |                  |
| 7                            | L2   | All MCs   | 226                   | 4.7  | 226                   | 4.7  | 0.407     | 6.7         | LOS A            | 5.0               | 37.1          | 0.25      | 0.46           | 0.25                | 34.2             |
| 8                            | T1   | All MCs   | 722                   | 7.3  | 722                   | 7.3  | *0.509    | 5.4         | LOS A            | 7.7               | 57.2          | 0.28      | 0.31           | 0.28                | 41.7             |
| Approach                     |      |           | 948                   | 6.7  | 948                   | 6.7  | 0.509     | 5.7         | LOS A            | 7.7               | 57.2          | 0.27      | 0.35           | 0.27                | 39.3             |
| SouthWest: Burrows Ave (SW)  |      |           |                       |      |                       |      |           |             |                  |                   |               |           |                |                     |                  |
| 10                           | L2   | All MCs   | 20                    | 47.4 | 20                    | 47.4 | *0.216    | 61.7        | LOS E            | 0.9               | 9.2           | 0.97      | 0.69           | 0.97                | 10.0             |
| 11                           | T1   | All MCs   | 3                     | 0.0  | 3                     | 0.0  | 0.050     | 48.9        | LOS D            | 0.3               | 2.7           | 0.95      | 0.64           | 0.95                | 16.6             |
| 12                           | R2   | All MCs   | 8                     | 12.5 | 8                     | 12.5 | 0.044     | 51.8        | LOS D            | 0.4               | 3.2           | 0.91      | 0.67           | 0.91                | 15.2             |
| Approach                     |      |           | 32                    | 33.3 | 32                    | 33.3 | 0.216     | 57.8        | LOS E            | 0.9               | 9.2           | 0.96      | 0.68           | 0.96                | 12.1             |
| All Vehicles                 |      |           | 1894                  | 4.5  | 1894                  | 4.5  | 0.509     | 15.1        | LOS B            | 8.6               | 60.8          | 0.47      | 0.45           | 0.47                | 24.2             |

Site Level of Service (LOS) Method: Delay (RTA NSW). Site LOS Method is specified in the Network Data dialog (Override Site Data tab).

Vehicle movement LOS values are based on average delay per movement.

Intersection and Approach LOS values are based on average delay for all vehicle movements.

Delay Model: SIDRA Standard (Control Delay: Geometric Delay is included).

Queue Model: SIDRA queue estimation methods are used for Back of Queue and Queue at Start of Green.

Gap-Acceptance Capacity Formula: SIDRA Standard (Akçelik M3D).

HV (%) values are calculated for All Movement Classes of All Heavy Vehicle Model Designation.

Arrival Flows used in performance calculations are adjusted to include any Initial Queued Demand and Upstream Capacity Constraint effects.

\* Critical Movement (Signal Timing)

| Pedestrian Movement Performance |          |           |             |                  |                       |        |           |                |             |              |             |
|---------------------------------|----------|-----------|-------------|------------------|-----------------------|--------|-----------|----------------|-------------|--------------|-------------|
| Mov ID                          | Crossing | Dem. Flow | Aver. Delay | Level of Service | AVERAGE BACK OF QUEUE |        | Prop. Que | Eff. Stop Rate | Travel Time | Travel Dist. | Aver. Speed |
|                                 |          | ped/h     | sec         |                  | [ Ped                 | Dist ] |           |                | sec         | m            | m/sec       |
|                                 |          |           |             |                  | ped                   | m      |           |                |             |              |             |
| SouthEast: Gleeson Ave (SE)     |          |           |             |                  |                       |        |           |                |             |              |             |
| P1                              | Full     | 15        | 42.8        | LOS E            | 0.0                   | 0.0    | 0.88      | 0.88           | 59.5        | 20.0         | 0.34        |
| NorthEast: Burrows Ave (NE)     |          |           |             |                  |                       |        |           |                |             |              |             |
| P2                              | Full     | 116       | 43.0        | LOS E            | 0.3                   | 0.3    | 0.89      | 0.89           | 59.6        | 20.0         | 0.34        |
| NorthWest: Gleeson Ave (NW)     |          |           |             |                  |                       |        |           |                |             |              |             |
| P3                              | Full     | 115       | 40.4        | LOS E            | 0.3                   | 0.3    | 0.86      | 0.86           | 57.0        | 20.0         | 0.35        |
| SouthWest: Burrows Ave (SW)     |          |           |             |                  |                       |        |           |                |             |              |             |
| P4                              | Full     | 63        | 44.7        | LOS E            | 0.2                   | 0.2    | 0.90      | 0.90           | 61.3        | 20.0         | 0.33        |
| All Pedestrians                 |          | 308       | 42.3        | LOS E            | 0.3                   | 0.3    | 0.88      | 0.88           | 59.0        | 20.0         | 0.34        |

Level of Service (LOS) Method: SIDRA Pedestrian LOS Method (Based on Average Delay)

Pedestrian movement LOS values are based on average delay per pedestrian movement.

Intersection LOS value for Pedestrians is based on average delay for all pedestrian movements.

**SIDRA INTERSECTION 9.1 | Copyright © 2000-2022 Akcelik and Associates Pty Ltd | sidrasolutions.com**

Organisation: AECOM AUSTRALIA PTY LTD | Licence: NETWORK / Enterprise Level 1 | Processed: Monday, 17 July 2023 10:22:14 AM

Project: C:\Users\YeungMAECOM\ANZ-NAC-Sydney Metro-Sydney Metro C&SW Operational Monitoring - General\400\_Technical\432\_Traffic Analysis\SIDRA Modelling\01 Models (Geometry Only)\Block 1\Rev1\_Review\09 SM C&SW\_SYD (Block 1)\_SH.sip9

# MOVEMENT SUMMARY

Site: SYD03 [SYD03 Burrows Ave / George St (Site Folder: Block 1 Model - 2023 Weekend Peak)]

Output produced by SIDRA INTERSECTION Version: 9.1.1.200

NA

Site Category: (None)

Give-Way (Two-Way)

| Vehicle Movement Performance |      |           |              |     |               |     |           |             |                  |                   |          |           |                |                     |             |
|------------------------------|------|-----------|--------------|-----|---------------|-----|-----------|-------------|------------------|-------------------|----------|-----------|----------------|---------------------|-------------|
| Mov ID                       | Turn | Mov Class | Demand Flows |     | Arrival Flows |     | Deg. Satn | Aver. Delay | Level of Service | 95% Back Of Queue |          | Prop. Que | Eff. Stop Rate | Aver. No. of Cycles | Aver. Speed |
|                              |      |           | [ Total HV ] | %   | [ Total HV ]  | %   | v/c       | sec         |                  | [ Veh. ]          | [ Dist ] |           |                |                     | km/h        |
|                              |      |           | veh/h        |     | veh/h         |     |           |             |                  | veh               | m        |           |                |                     |             |
| SouthEast: George St (SE)    |      |           |              |     |               |     |           |             |                  |                   |          |           |                |                     |             |
| 4                            | L2   | All MCs   | 18           | 5.9 | 18            | 5.9 | 0.020     | 8.4         | LOSA             | 0.1               | 0.4      | 0.25      | 0.89           | 0.25                | 30.4        |
| 6                            | R2   | All MCs   | 3            | 0.0 | 3             | 0.0 | 0.020     | 9.1         | LOSA             | 0.1               | 0.4      | 0.25      | 0.89           | 0.25                | 26.8        |
| Approach                     |      |           | 21           | 5.0 | 21            | 5.0 | 0.020     | 8.5         | LOSA             | 0.1               | 0.4      | 0.25      | 0.89           | 0.25                | 29.9        |
| NorthEast: Burrows Ave (NE)  |      |           |              |     |               |     |           |             |                  |                   |          |           |                |                     |             |
| 7                            | L2   | All MCs   | 7            | 0.0 | 7             | 0.0 | 0.171     | 3.7         | LOSA             | 0.9               | 6.4      | 0.12      | 0.05           | 0.12                | 41.3        |
| 8                            | T1   | All MCs   | 191          | 2.8 | 191           | 2.8 | 0.171     | 0.2         | LOSA             | 0.9               | 6.4      | 0.12      | 0.05           | 0.12                | 47.8        |
| Approach                     |      |           | 198          | 2.7 | 198           | 2.7 | 0.171     | 0.3         | NA               | 0.9               | 6.4      | 0.12      | 0.05           | 0.12                | 47.5        |
| SouthWest: Burrows Ave (SW)  |      |           |              |     |               |     |           |             |                  |                   |          |           |                |                     |             |
| 2                            | T1   | All MCs   | 222          | 1.4 | 222           | 1.4 | 0.204     | 0.2         | LOSA             | 0.9               | 6.7      | 0.10      | 0.07           | 0.10                | 46.8        |
| 3                            | R2   | All MCs   | 18           | 0.0 | 18            | 0.0 | 0.204     | 5.3         | LOSA             | 0.9               | 6.7      | 0.10      | 0.07           | 0.10                | 41.8        |
| Approach                     |      |           | 240          | 1.3 | 240           | 1.3 | 0.204     | 0.6         | NA               | 0.9               | 6.7      | 0.10      | 0.07           | 0.10                | 46.2        |
| All Vehicles                 |      |           | 459          | 2.1 | 459           | 2.1 | 0.204     | 0.8         | NA               | 0.9               | 6.7      | 0.12      | 0.10           | 0.12                | 45.3        |

Site Level of Service (LOS) Method: Delay (RTA NSW). Site LOS Method is specified in the Parameter Settings dialog (Options tab).

Vehicle movement LOS values are based on average delay per movement.

Minor Road Approach LOS values are based on average delay for all vehicle movements.

NA (TWSC): Level of Service is not defined for major road approaches or the intersection as a whole for Two-Way Sign Control (HCM LOS rule).

Two-Way Sign Control Capacity Model: SIDRA Standard.

Delay Model: SIDRA Standard (Control Delay: Geometric Delay is included).

Queue Model: SIDRA queue estimation methods are used for Back of Queue and Queue at Start of Gap.

Gap-Acceptance Capacity Formula: SIDRA Standard (Akçelik M3D).

HV (%) values are calculated for All Movement Classes of All Heavy Vehicle Model Designation.

Arrival Flows used in performance calculations are adjusted to include any Initial Queued Demand and Upstream Capacity Constraint effects.

---

**SIDRA INTERSECTION 9.1 | Copyright © 2000-2022 Akcelik and Associates Pty Ltd | sidrasolutions.com**

Organisation: AECOM AUSTRALIA PTY LTD | Licence: NETWORK / Enterprise Level 1 | Processed: Friday, 14 July 2023 5:39:01 PM

Project: C:\Users\Yeung\AECOM\ANZ-NAC-Sydney Metro-Sydney Metro C&SW Operational Monitoring - General\400\_Technical\432\_Traffic Analysis\SIDRA Modelling\01 Models (Geometry Only)\Block 1\Rev1\\_Review\09 SM C&SW\_SYD (Block 1)\_SH.sip9

# MOVEMENT SUMMARY

 Site: SYD04 [SYD04 Pedestrian Mid-block Crossing at Sydenham Rd (Site Folder: Block 1 Model - 2023 Weekend Peak)]

Output produced by SIDRA INTERSECTION Version: 9.1.1.200

TCS 4946

Site Category: (None)

Pedestrian Crossing (Signalised) - EQUISAT (Fixed-Time/SCATS) Isolated Cycle Time = 110 seconds (Site User-Given Phase Times)

| Vehicle Movement Performance |      |           |                       |     |                       |     |           |             |                  |                   |               |           |                |                     |             |
|------------------------------|------|-----------|-----------------------|-----|-----------------------|-----|-----------|-------------|------------------|-------------------|---------------|-----------|----------------|---------------------|-------------|
| Mov ID                       | Turn | Mov Class | Demand Flows          |     | Arrival Flows         |     | Deg. Satn | Aver. Delay | Level of Service | 95% Back Of Queue |               | Prop. Que | Eff. Stop Rate | Aver. No. of Cycles | Aver. Speed |
|                              |      |           | [ Total HV ]<br>veh/h | %   | [ Total HV ]<br>veh/h | %   |           |             |                  | [ Veh. ]<br>veh   | [ Dist ]<br>m |           |                |                     |             |
| NorthWest: Sydenham Rd (NW)  |      |           |                       |     |                       |     |           |             |                  |                   |               |           |                |                     |             |
| 8                            | T1   | All MCs   | 1046                  | 4.2 | 1046                  | 4.2 | * 0.394   | 5.4         | LOSA             | 7.5               | 54.5          | 0.43      | 0.41           | 0.43                | 46.6        |
| Approach                     |      |           | 1046                  | 4.2 | 1046                  | 4.2 | 0.394     | 5.4         | LOSA             | 7.5               | 54.5          | 0.43      | 0.41           | 0.43                | 46.6        |
| All Vehicles                 |      |           | 1046                  | 4.2 | 1046                  | 4.2 | 0.394     | 5.4         | LOSA             | 7.5               | 54.5          | 0.43      | 0.41           | 0.43                | 46.6        |

Site Level of Service (LOS) Method: Delay (RTA NSW). Site LOS Method is specified in the Parameter Settings dialog (Options tab).

Vehicle movement LOS values are based on average delay per movement.

Intersection and Approach LOS values are based on average delay for all vehicle movements.

Delay Model: SIDRA Standard (Control Delay: Geometric Delay is included).

Queue Model: SIDRA queue estimation methods are used for Back of Queue and Queue at Start of Green.

Gap-Acceptance Capacity Formula: SIDRA Standard (Akçelik M3D).

HV (%) values are calculated for All Movement Classes of All Heavy Vehicle Model Designation.

Arrival Flows used in performance calculations are adjusted to include any Initial Queued Demand and Upstream Capacity Constraint effects.

\* Critical Movement (Signal Timing)



| Pedestrian Movement Performance |          |       |       |       |                  |                       |        |           |                |             |              |             |
|---------------------------------|----------|-------|-------|-------|------------------|-----------------------|--------|-----------|----------------|-------------|--------------|-------------|
| Mov ID                          | Crossing | Input | Dem.  | Aver. | Level of Service | AVERAGE BACK OF QUEUE |        | Prop. Que | Eff. Stop Rate | Travel Time | Travel Dist. | Aver. Speed |
|                                 |          | Vol.  | Flow  | Delay |                  | [ Ped                 | Dist ] |           |                |             |              |             |
|                                 |          | ped/h | ped/h | sec   |                  |                       | ped    | m         |                |             |              |             |
| SouthEast: Sydenham Rd (SE)     |          |       |       |       |                  |                       |        |           |                |             |              |             |
| P1                              | Full     | 20    | 21    | 32.4  | LOS D            | 0.1                   | 0.1    | 0.84      | 0.84           | 199.1       | 200.0        | 1.00        |
| All                             |          | 20    | 21    | 32.4  | LOS D            | 0.1                   | 0.1    | 0.84      | 0.84           | 199.1       | 200.0        | 1.00        |
| Pedestrians                     |          |       |       |       |                  |                       |        |           |                |             |              |             |

Level of Service (LOS) Method: SIDRA Pedestrian LOS Method (Based on Average Delay)

Pedestrian movement LOS values are based on average delay per pedestrian movement.

Intersection LOS value for Pedestrians is based on average delay for all pedestrian movements.

---

**SIDRA INTERSECTION 9.1 | Copyright © 2000-2022 Akcelik and Associates Pty Ltd | sidrasolutions.com**

Organisation: AECOM AUSTRALIA PTY LTD | Licence: NETWORK / Enterprise Level 1 | Processed: Thursday, 13 July 2023 11:45:02 AM

Project: C:\Users\YeungMA\AECOM\ANZ-NAC-Sydney Metro-Sydney Metro C&SW Operational Monitoring - General\400\_Technical\432\_Traffic Analysis\SIDRA Modelling\01 Models (Geometry Only)\Block 1\Rev1\_Review\09 SM C&SW\_SYD (Block 1)\_SH.sip9

# MOVEMENT SUMMARY

Site: SYD05 [SYD05 Marrickville Rd / Buckley St (Site Folder: Block 1 Model - 2023 Weekend Peak)]

Output produced by SIDRA INTERSECTION Version: 9.1.1.200

NA

Site Category: (None)

Give-Way (Two-Way)

| Vehicle Movement Performance    |      |           |              |     |               |     |           |             |                  |                   |          |           |                |                     |             |
|---------------------------------|------|-----------|--------------|-----|---------------|-----|-----------|-------------|------------------|-------------------|----------|-----------|----------------|---------------------|-------------|
| Mov ID                          | Turn | Mov Class | Demand Flows |     | Arrival Flows |     | Deg. Satn | Aver. Delay | Level of Service | 95% Back Of Queue |          | Prop. Que | Eff. Stop Rate | Aver. No. of Cycles | Aver. Speed |
|                                 |      |           | [ Total HV ] | %   | [ Total HV ]  | %   | v/c       | sec         |                  | [ Veh. ]          | [ Dist ] |           |                |                     | km/h        |
|                                 |      |           | veh/h        |     | veh/h         |     |           |             |                  | veh               | m        |           |                |                     |             |
| SouthEast: Marrickville Rd (SE) |      |           |              |     |               |     |           |             |                  |                   |          |           |                |                     |             |
| 2                               | T1   | All MCs   | 588          | 2.0 | 588           | 2.0 | 0.308     | 0.0         | LOSA             | 0.0               | 0.0      | 0.00      | 0.00           | 0.00                | 59.8        |
| 3                               | R2   | All MCs   | 524          | 1.4 | 524           | 1.4 | 0.306     | 5.9         | LOSA             | 1.6               | 11.4     | 0.13      | 0.60           | 0.13                | 45.3        |
| Approach                        |      |           | 1113         | 1.7 | 1113          | 1.7 | 0.308     | 2.8         | NA               | 1.6               | 11.4     | 0.06      | 0.28           | 0.06                | 52.8        |
| NorthWest: Marrickville Rd (NW) |      |           |              |     |               |     |           |             |                  |                   |          |           |                |                     |             |
| 7                               | L2   | All MCs   | 409          | 2.6 | 409           | 2.6 | 0.301     | 5.8         | LOSA             | 1.4               | 10.3     | 0.15      | 0.55           | 0.15                | 49.7        |
| Approach                        |      |           | 409          | 2.6 | 409           | 2.6 | 0.301     | 5.8         | NA               | 1.4               | 10.3     | 0.15      | 0.55           | 0.15                | 49.7        |
| All Vehicles                    |      |           | 1522         | 1.9 | 1522          | 1.9 | 0.308     | 3.6         | NA               | 1.6               | 11.4     | 0.09      | 0.35           | 0.09                | 51.8        |

Site Level of Service (LOS) Method: Delay (RTA NSW). Site LOS Method is specified in the Parameter Settings dialog (Options tab).

Vehicle movement LOS values are based on average delay per movement.

Minor Road Approach LOS values are based on average delay for all vehicle movements.

NA (TWSC): Level of Service is not defined for major road approaches or the intersection as a whole for Two-Way Sign Control (HCM LOS rule).

Two-Way Sign Control Capacity Model: SIDRA Standard.

Delay Model: SIDRA Standard (Control Delay: Geometric Delay is included).

Queue Model: SIDRA queue estimation methods are used for Back of Queue and Queue at Start of Gap.

Gap-Acceptance Capacity Formula: SIDRA Standard (Akçelik M3D).

HV (%) values are calculated for All Movement Classes of All Heavy Vehicle Model Designation.

Arrival Flows used in performance calculations are adjusted to include any Initial Queued Demand and Upstream Capacity Constraint effects.

---

**SIDRA INTERSECTION 9.1 | Copyright © 2000-2022 Akcelik and Associates Pty Ltd | sidrasolutions.com**

Organisation: AECOM AUSTRALIA PTY LTD | Licence: NETWORK / Enterprise Level 1 | Processed: Monday, 17 July 2023 9:51:57 AM

Project: C:\Users\Yeung\AECOM\ANZ-NAC-Sydney Metro-Sydney Metro C&SW Operational Monitoring - General\400\_Technical\432\_Traffic Analysis\SIDRA Modelling\01 Models (Geometry Only)\Block 1\Rev1\\_Review\09 SM C&SW\_SYD (Block 1)\_SH.sip9

# MOVEMENT SUMMARY

Site: SYD06 [SYD06 Sydenham Rd / Buckley St (Site Folder: Block 1 Model - 2023 Weekend Peak)]

Output produced by SIDRA INTERSECTION Version: 9.1.1.200

NA

Site Category: (None)

Give-Way (Two-Way)

| Vehicle Movement Performance |      |           |              |     |               |     |           |             |                  |                   |            |           |                |                     |             |
|------------------------------|------|-----------|--------------|-----|---------------|-----|-----------|-------------|------------------|-------------------|------------|-----------|----------------|---------------------|-------------|
| Mov ID                       | Turn | Mov Class | Demand Flows |     | Arrival Flows |     | Deg. Satn | Aver. Delay | Level of Service | 95% Back Of Queue |            | Prop. Que | Eff. Stop Rate | Aver. No. of Cycles | Aver. Speed |
|                              |      |           | [ Total HV ] | %   | [ Total HV ]  | %   | v/c       | sec         |                  | [ Veh. veh        | [ Dist ] m |           |                |                     | km/h        |
| NorthWest: Sydenham Rd (NW)  |      |           |              |     |               |     |           |             |                  |                   |            |           |                |                     |             |
| 2                            | T1   | All MCs   | 595          | 3.5 | 595           | 3.5 | 0.315     | 0.1         | LOSA             | 0.0               | 0.0        | 0.00      | 0.00           | 0.00                | 59.8        |
| Approach                     |      |           | 595          | 3.5 | 595           | 3.5 | 0.315     | 0.1         | NA               | 0.0               | 0.0        | 0.00      | 0.00           | 0.00                | 59.8        |
| SouthWest: Buckley St (SW)   |      |           |              |     |               |     |           |             |                  |                   |            |           |                |                     |             |
| 4                            | L2   | All MCs   | 499          | 1.7 | 499           | 1.7 | 0.274     | 5.7         | LOSA             | 0.0               | 0.0        | 0.00      | 0.53           | 0.00                | 51.2        |
| 6                            | R2   | All MCs   | 388          | 3.0 | 388           | 3.0 | 0.216     | 5.8         | LOSA             | 0.0               | 0.0        | 0.00      | 0.63           | 0.00                | 43.7        |
| Approach                     |      |           | 887          | 2.3 | 887           | 2.3 | 0.274     | 5.7         | NA               | 0.0               | 0.0        | 0.00      | 0.57           | 0.00                | 48.7        |
| All Vehicles                 |      |           | 1482         | 2.8 | 1482          | 2.8 | 0.315     | 3.5         | NA               | 0.0               | 0.0        | 0.00      | 0.34           | 0.00                | 52.4        |

Site Level of Service (LOS) Method: Delay (RTA NSW). Site LOS Method is specified in the Parameter Settings dialog (Options tab).

Vehicle movement LOS values are based on average delay per movement.

Minor Road Approach LOS values are based on average delay for all vehicle movements.

NA (TWSC): Level of Service is not defined for major road approaches or the intersection as a whole for Two-Way Sign Control (HCM LOS rule).

Two-Way Sign Control Capacity Model: SIDRA Standard.

Delay Model: SIDRA Standard (Control Delay: Geometric Delay is included).

Queue Model: SIDRA queue estimation methods are used for Back of Queue and Queue at Start of Gap.

Gap-Acceptance Capacity Formula: SIDRA Standard (Akçelik M3D).

HV (%) values are calculated for All Movement Classes of All Heavy Vehicle Model Designation.

Arrival Flows used in performance calculations are adjusted to include any Initial Queued Demand and Upstream Capacity Constraint effects.

---

**SIDRA INTERSECTION 9.1 | Copyright © 2000-2022 Akcelik and Associates Pty Ltd | sidrasolutions.com**

Organisation: AECOM AUSTRALIA PTY LTD | Licence: NETWORK / Enterprise Level 1 | Processed: Thursday, 13 July 2023 11:45:03 AM

Project: C:\Users\Yeung\AECOM\ANZ-NAC-Sydney Metro-Sydney Metro C&SW Operational Monitoring - General\400\_Technical\432\_Traffic Analysis\SIDRA Modelling\01 Models (Geometry Only)\Block 1\Rev1\\_Review\09 SM C&SW\_SYD (Block 1)\_SH.sip9